

Char-Broil
KEEPERS OF THE FLAME

**SILVER
SMOKER™**

Smoker, BBQ and Grill



Tools needed for assembly:

2 Adjustable Wrenches
7/16" Open-End Wrench
Flat Screwdriver
Hammer



CAUTION



THIS UNIT IS HEAVY. DO NOT assemble without helper.

Some parts may contain sharp edges - especially as noted in manual. Wear protective gloves if necessary.

Read and follow all safety statements, warning, assembly instructions and use & care directions before attempting to assemble and cook.



WARNING



CARBON MONOXIDE HAZARD

Burning charcoal inside can kill you. It gives off carbon monoxide, which has no odor. NEVER burn charcoal inside homes, vehicles or tents.

STOP!

Missing a part?

No need to go back to the store!

The store where you made your purchase does not stock parts for this item. If you need parts, whether they are missing or damaged, call the Customer Service toll free Help Line.

Call us and we will gladly ship the part you need
FREE OF CHARGE.

Call Our Help Line
1-800-232-3398



PARTS LIST

| ITEM | DESCRIPTION |
|----------|----------------------------|
| 55700193 | SMOKER CHAMBER KIT |
| 55700194 | FIREBOX KIT |
| 55700195 | WOOD SHELF KIT |
| 55700442 | AXLE KIT |
| 55700443 | WHEEL KIT |
| 55700198 | LEG BRACE KIT |
| 55700199 | SMOKESTACK KIT |
| 55700200 | SHORT LEG KIT |
| 55700201 | LONG LEG KIT |
| 55700202 | SHELF BRACKET KIT |
| 55700203 | COVER PLATE KIT |
| 55700204 | DOOR LATCH KIT |
| 55700205 | LOGO PLATE KIT |
| 55700206 | 8" WOOD HANDLE KIT |
| 55700192 | BUTTERFLY DAMPER KIT |
| 42000010 | HARDWARE BAG |
| 10000074 | LEG CAPS |
| 40009916 | LARGE PORCELAIN GRATE SET |
| 40009925 | SMALL PORCELAIN GRATE |
| 40022811 | FIRE GRATE SET (3) |
| 46030090 | WOOD STORAGE RACK |
| 44830150 | GREASE CLIP |
| 40003010 | OPTIONAL TEMPERATURE GAUGE |
| 42802119 | ASSEMBLY INSTRUCTIONS |

1 **FIRST, GET A HELPER!** This unit is heavy and requires a second person for lifting and moving. **NEXT**, pick a suitable location to work. Open the carton and slit the corners so that the carton lays flat. This will give you a protective work surface during assembly.

TO BEGIN ASSEMBLY, build two leg assemblies by sliding the **long** leg sections into the **short** leg sections.

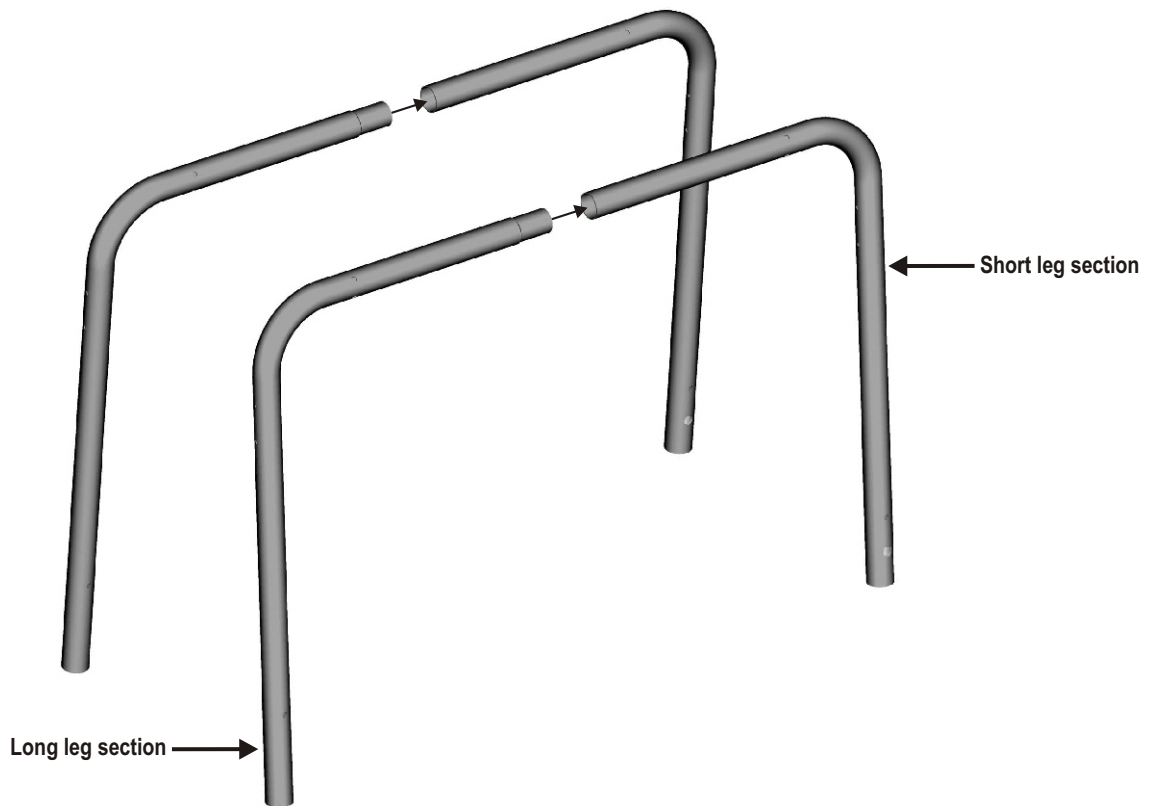

2 Attach leg braces to the outside of one leg assembly using **#10-24x1 $\frac{3}{4}$ " screws** and **#10-24 flange nuts**. *Make sure slotted (oval) hole is toward bottom of leg.* **Do not fully tighten screws until Step 8 is complete.**

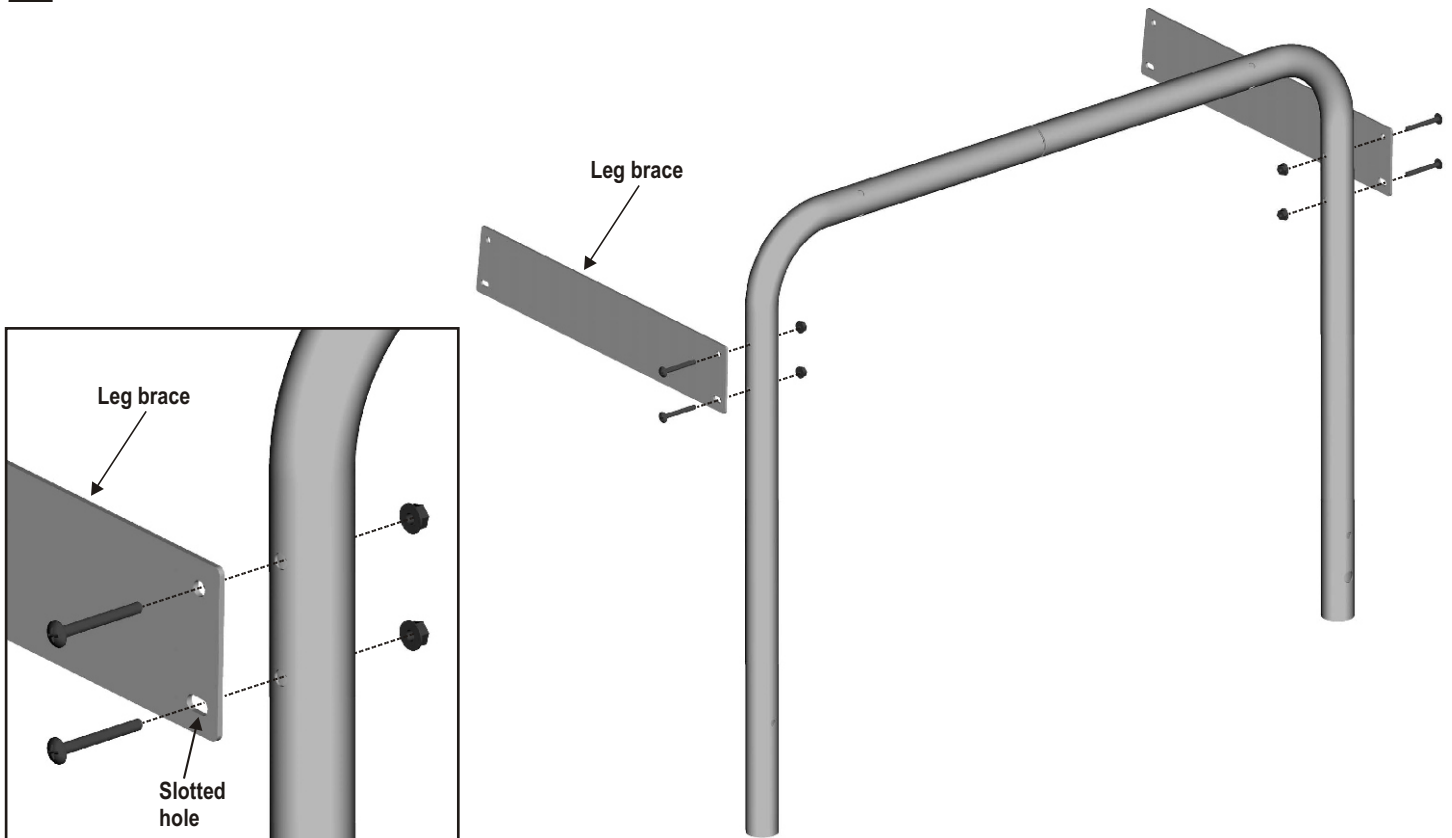

- 3** Lay the leg assembly on its side with legs braces pointing upward. Insert the wood rack hooks into leg holes and swing rack upward, parallel to leg braces.

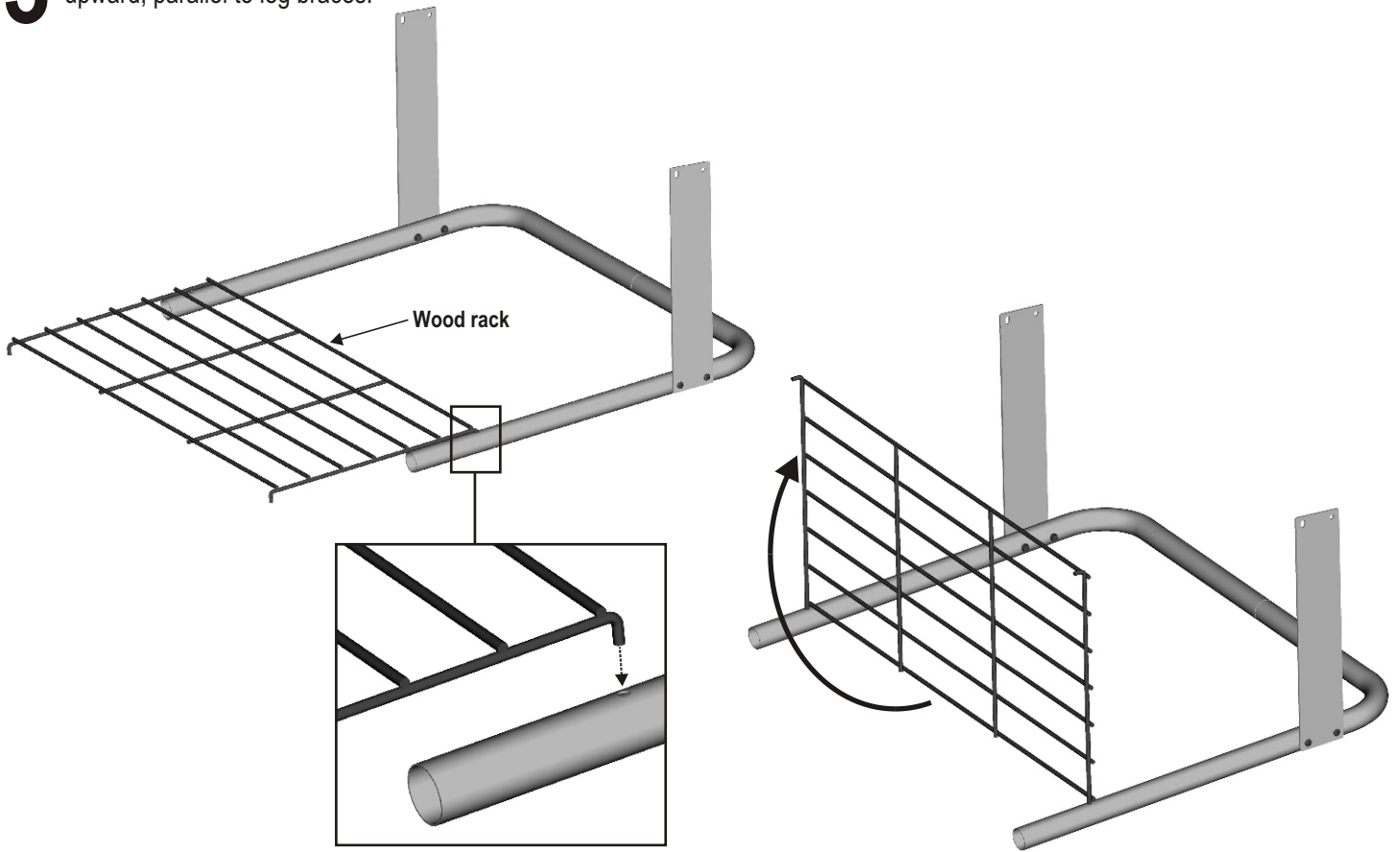

- 4** With the aid of a helper, place leg holes of remaining leg assembly over wood rack hooks and rotate leg assembly until it meets the leg braces. *Make sure both short legs are at one end of the rack and both long legs at the other end.* Attach to leg braces using #10-24x1 $\frac{3}{4}$ " screws and #10-24 flange nuts. Do not fully tighten screws until Step 8 is complete.

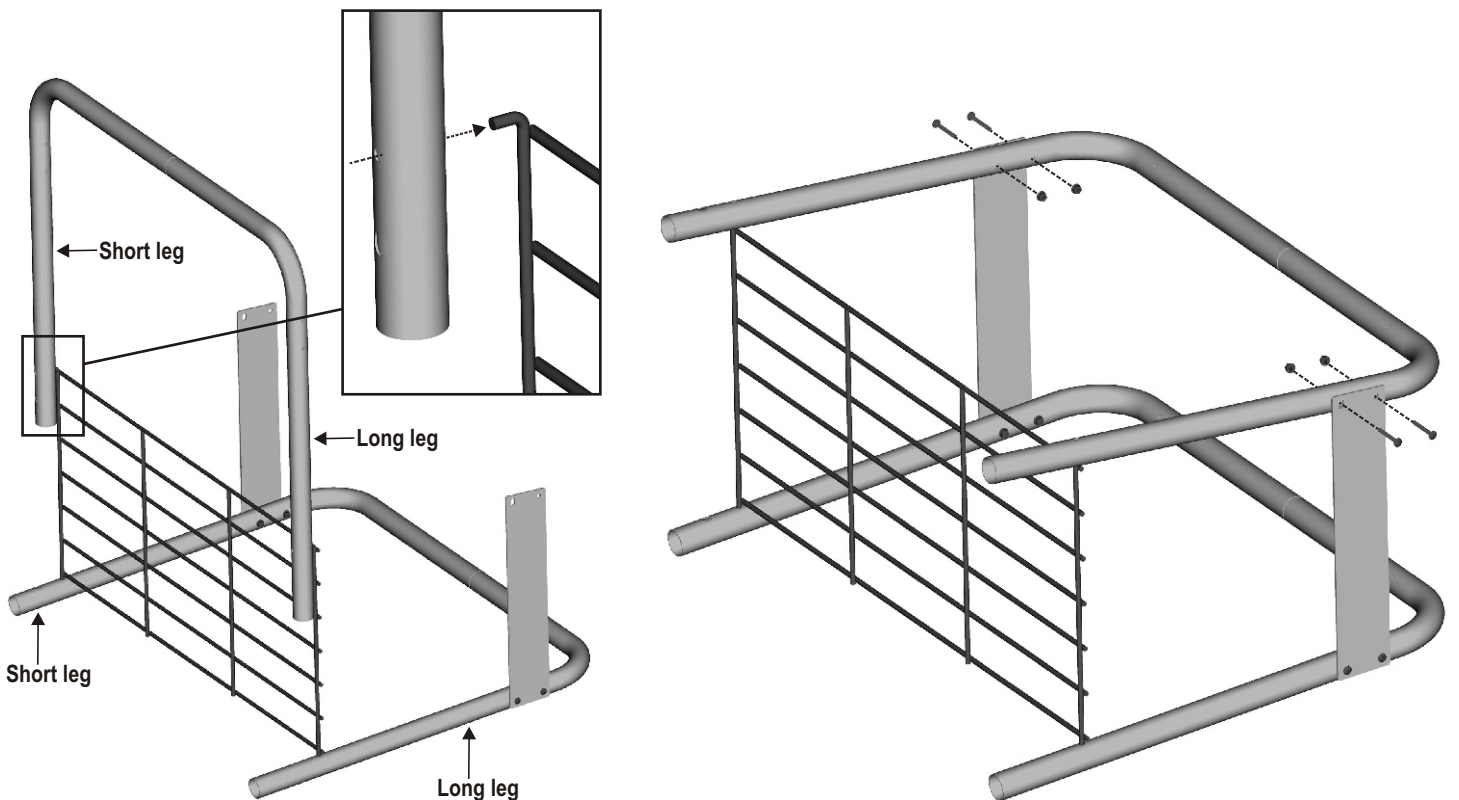

- 5** Insert a **cotter pin** into the hole at one end of the axle and bend the ends of the pin back so that it cannot be removed. Slide a wheel onto the axle. Slide the axle through the holes at the ends of the short legs. Slide remaining wheel onto axle and secure with remaining **cotter pin**.

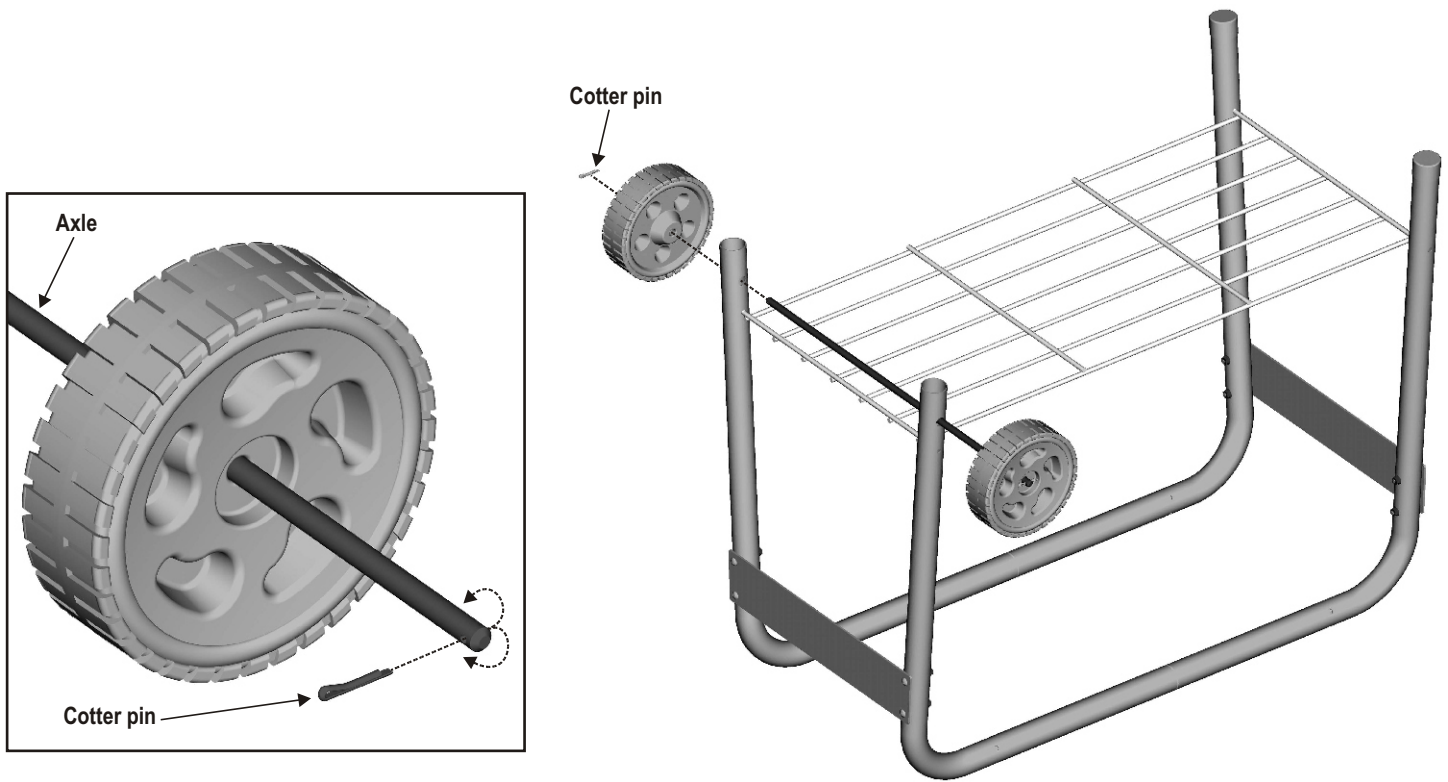

- 6** **NOTE:** Smoker chamber door not pictured for clarity.

Stand the leg assembly on end, wheels down. Stand the smoker chamber on its solid end, open end up. Place leg assembly against chamber, aligning holes in legs with holes in chamber. Attach legs to chamber using four **1/4-20x2" screws** and **1/4-20 flange nuts**. Insert screws from outside, flange nuts inside chamber.

FULLY TIGHTEN ALL SCREWS AND NUTS AT THIS TIME.

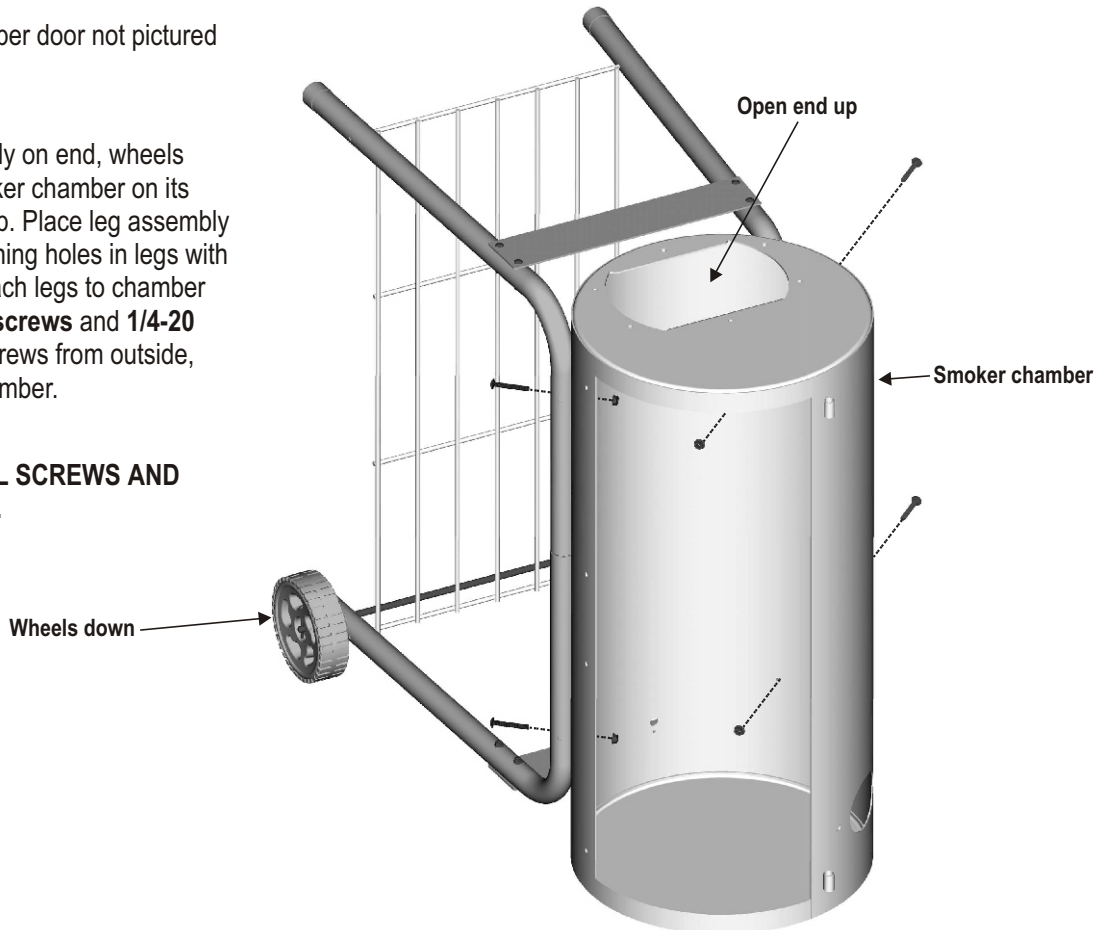

7 NOTE: Smoker chamber and firebox doors not pictured for clarity.

Diamond Fire™ Plate Installation - For models **without** Diamond Fire™ ignitor accessory, part number 22504850.

For models that feature the Diamond Fire™ ignitor accessory, supplemental instructions are included with ignitor.

First, locate the cover plate in the hardware box. At the bottom right end of the firebox there is an opening for the Diamond Fire™ ignitor accessory. Install the cover plate over the opening using two **#8-32x1/2"** screws and **#8-32 lock nuts**.

Second, align the hole pattern on the firebox with the pattern on the smoker chamber. *The firebox should be slightly offset from the smoker chamber.* Attach using six **1/4-20x3/4"** hex-head bolts and flat washer inside firebox and **1/4-20 flange nuts** inside smoker chamber.

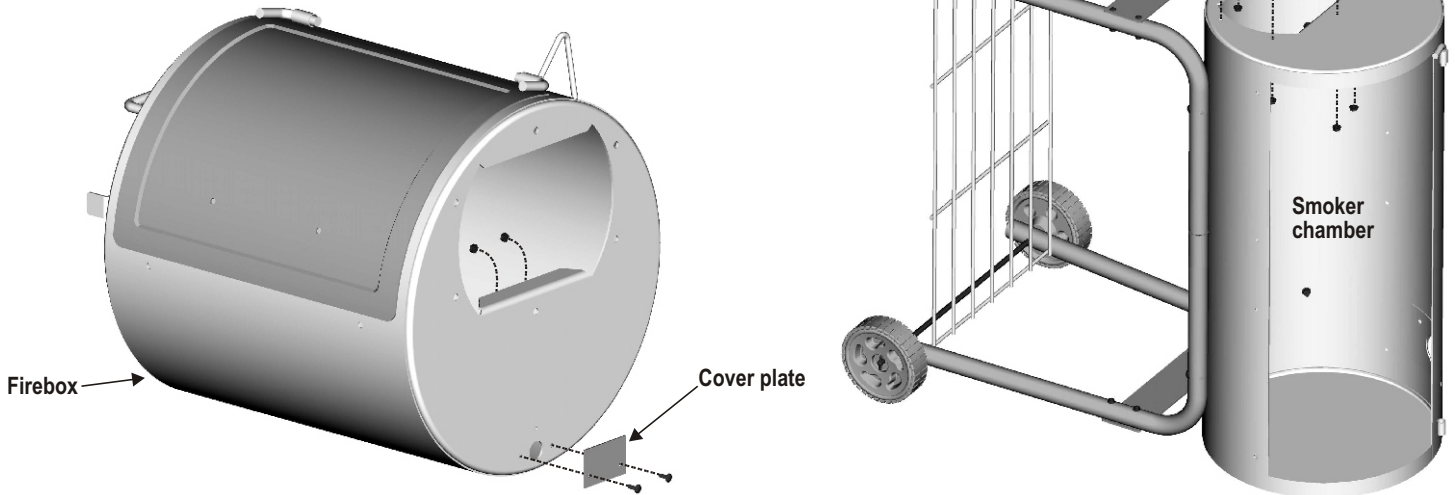

8 NOTE: Smoker chamber door not pictured for clarity.

From inside the smoker chamber, slide the smokestack through the large hole. Align the two holes in the smokestack plate with the holes in the chamber and secure with two **1/4-20x3/4"** hex-head bolts outside the chamber and **1/4-20 flange nuts** inside.

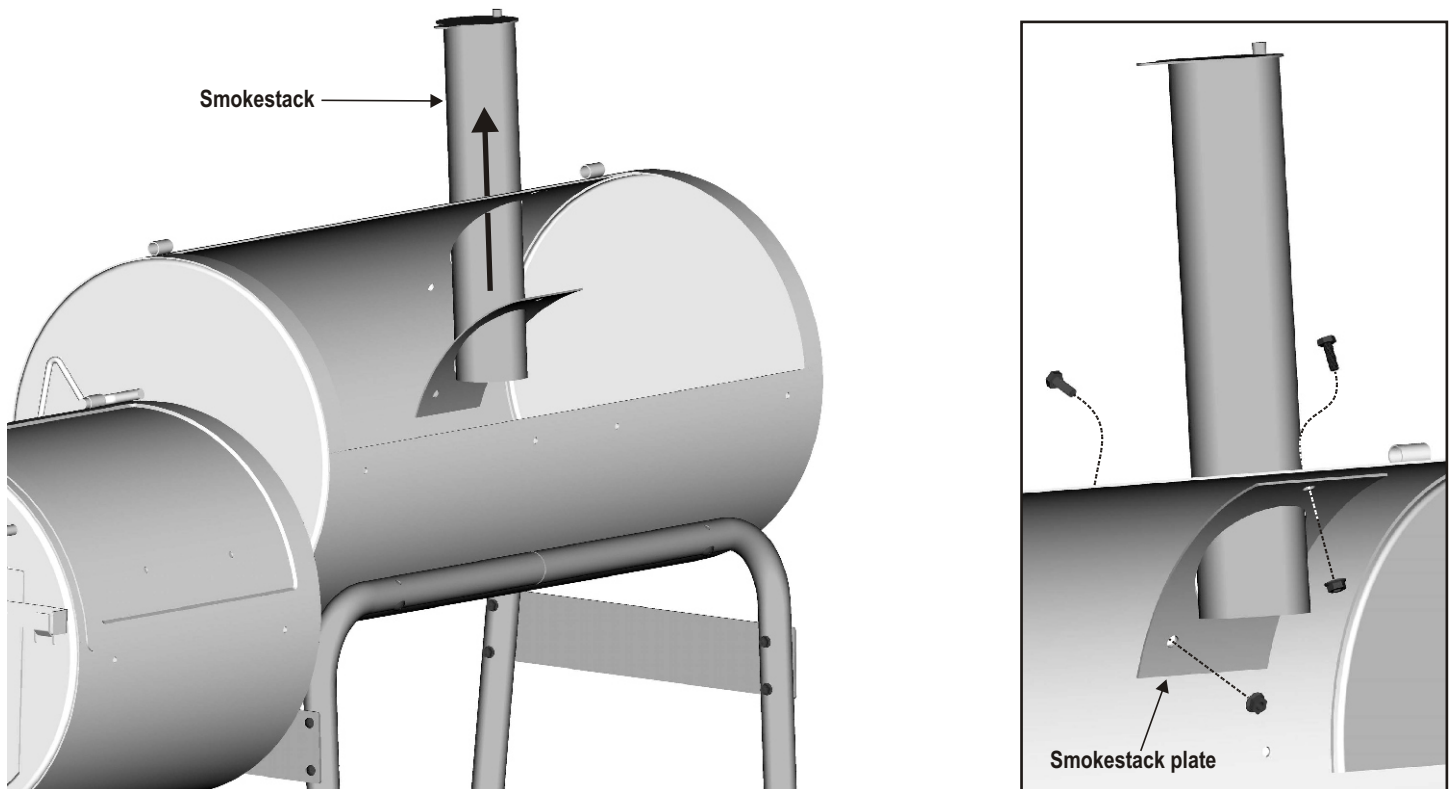

- 9** Attach wood handle to smoker chamber door using two **1/4-20x3"** screws, flat washers, handle spacers and **1/4-20 flange nuts**, as shown below. **Repeat to attach handle to firebox door.**

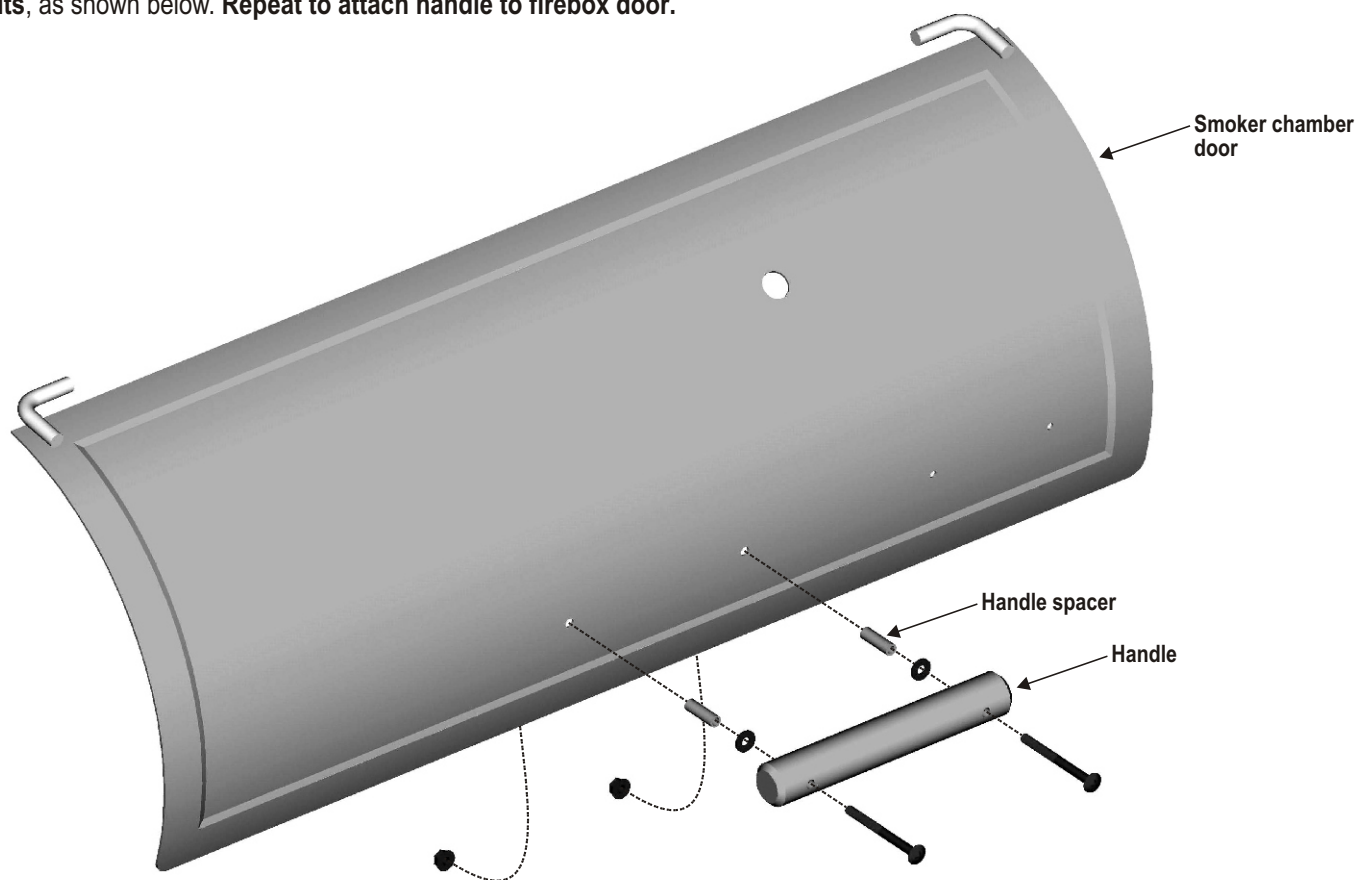

- 10** **NOTE:** Smoker chamber door not pictured for clarity. Install grate support screws in the **four rear holes** and **two front-center holes** in the smoker chamber. Use six **#10-24x1"** screws and **#10 flange nuts**.

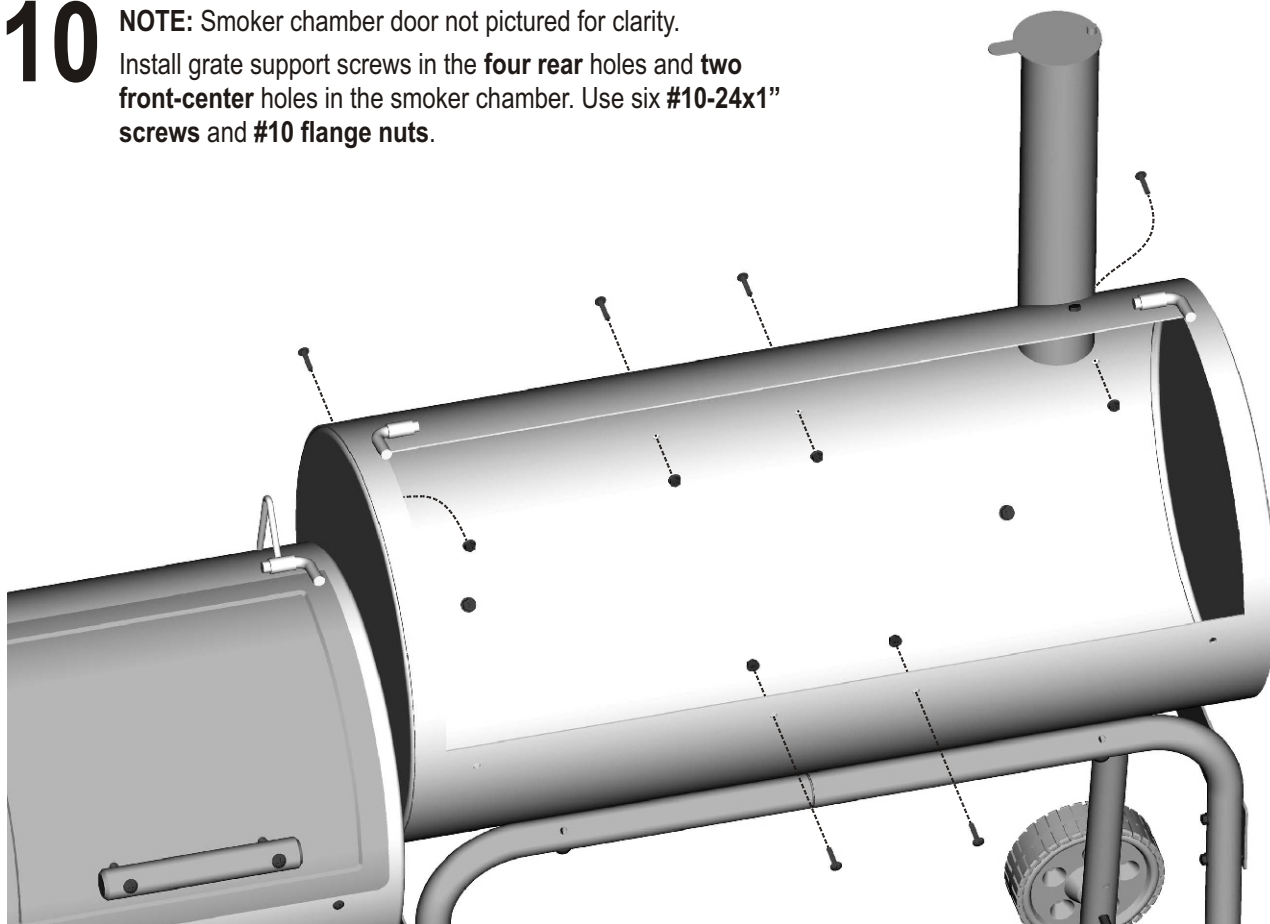

11

NOTE: Smoker chamber door not pictured for clarity.
Attach shelf brackets to outer holes on front of smoker chamber using two **1/4-20x1 1/4" hex-head bolts** and **1/4-20 flange nuts**. **DO NOT FULLY TIGHTEN.**

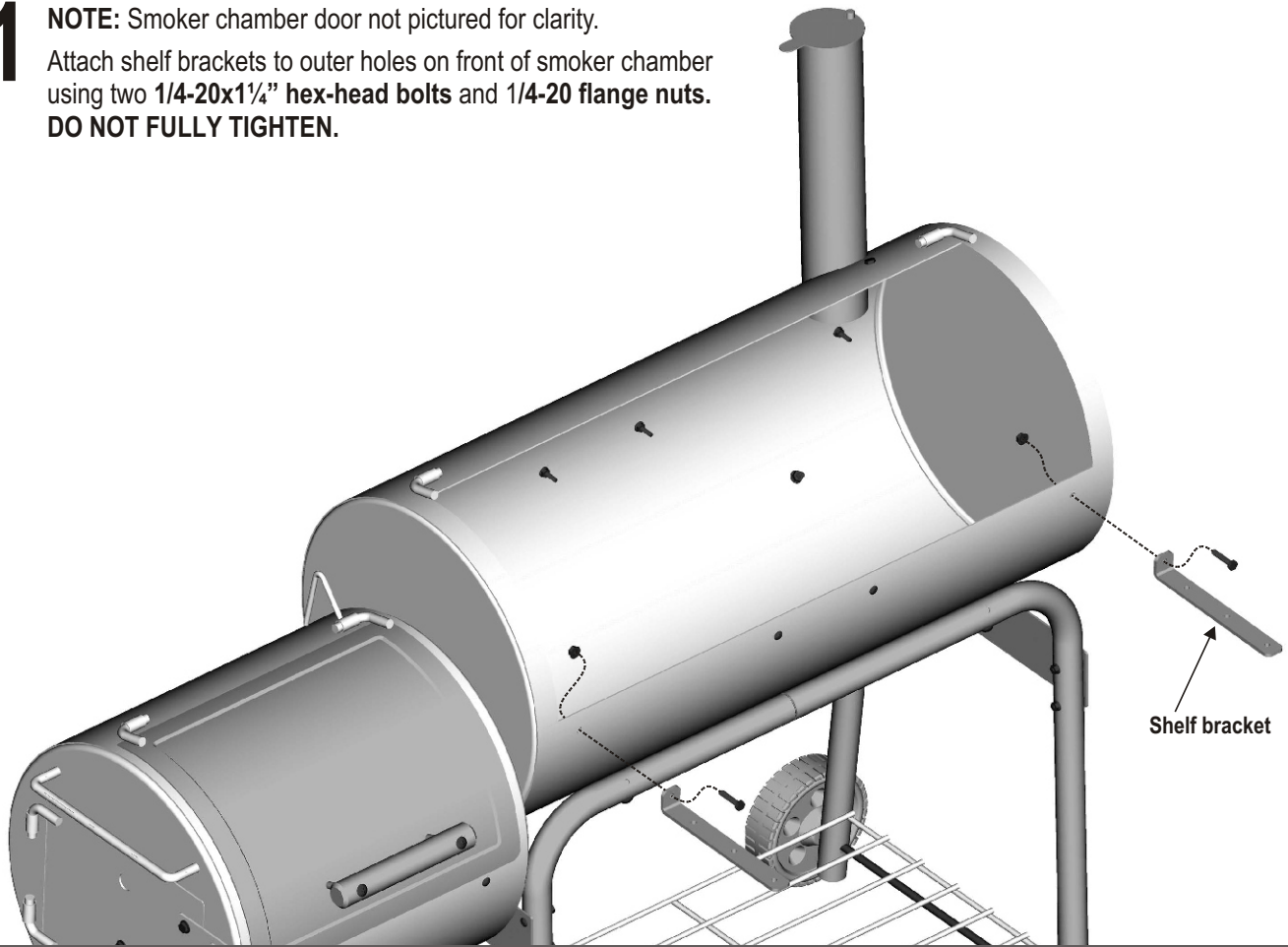

12

NOTE: Smoker chamber door not pictured for clarity.
First, attach shelf slats to the two outer holes in shelf brackets using two **#10-24x1" screws** and **#10-24 flange nuts** per slat. **DO NOT FULLY TIGHTEN SCREWS.** **Second**, fully tighten hex-head bolts on shelf brackets (installed in previous step). **Third**, attach remaining shelf slat to brackets with two **#10-24x1" screws** and **#10-24 flange nuts**. **FULLY TIGHTEN ALL SHELF SLAT SCREWS.**

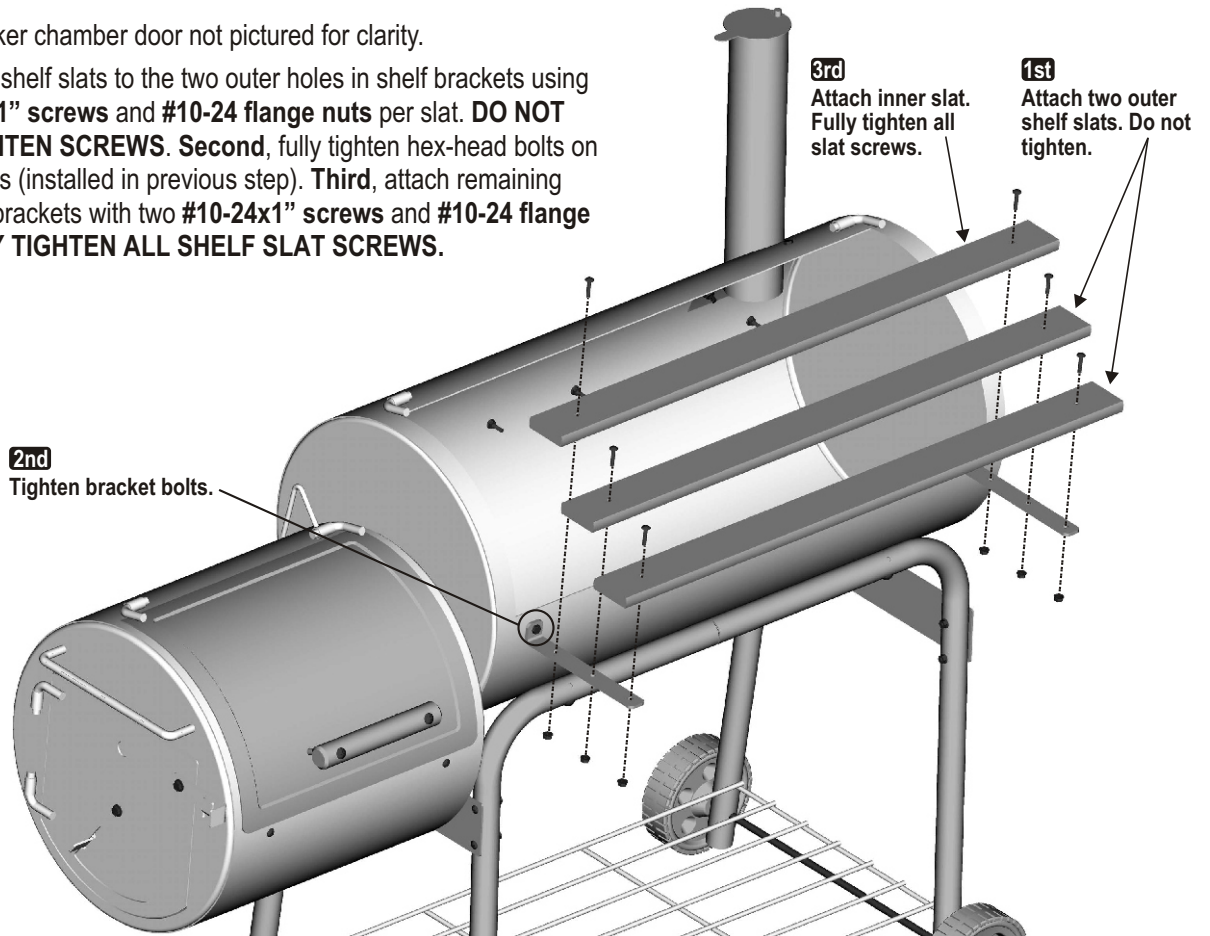

13 If you have purchased the optional 3" Temperature Gauge, part number 40003010, remove the attached nut, insert gauge stem into large hole in cooking chamber door and attach nut to gauge on inside of door. **DO NOT OVERTIGHTEN NUT.** Make sure text and graphics are aligned for easy viewing.

If you do not have a temperature gauge, install the **chrome hole plug** (provided) into temperature gauge hole in cooking chamber door.

If you would like to purchase the optional 3" Temperature Gauge, part number 40003010, call 1-800-232-3398.

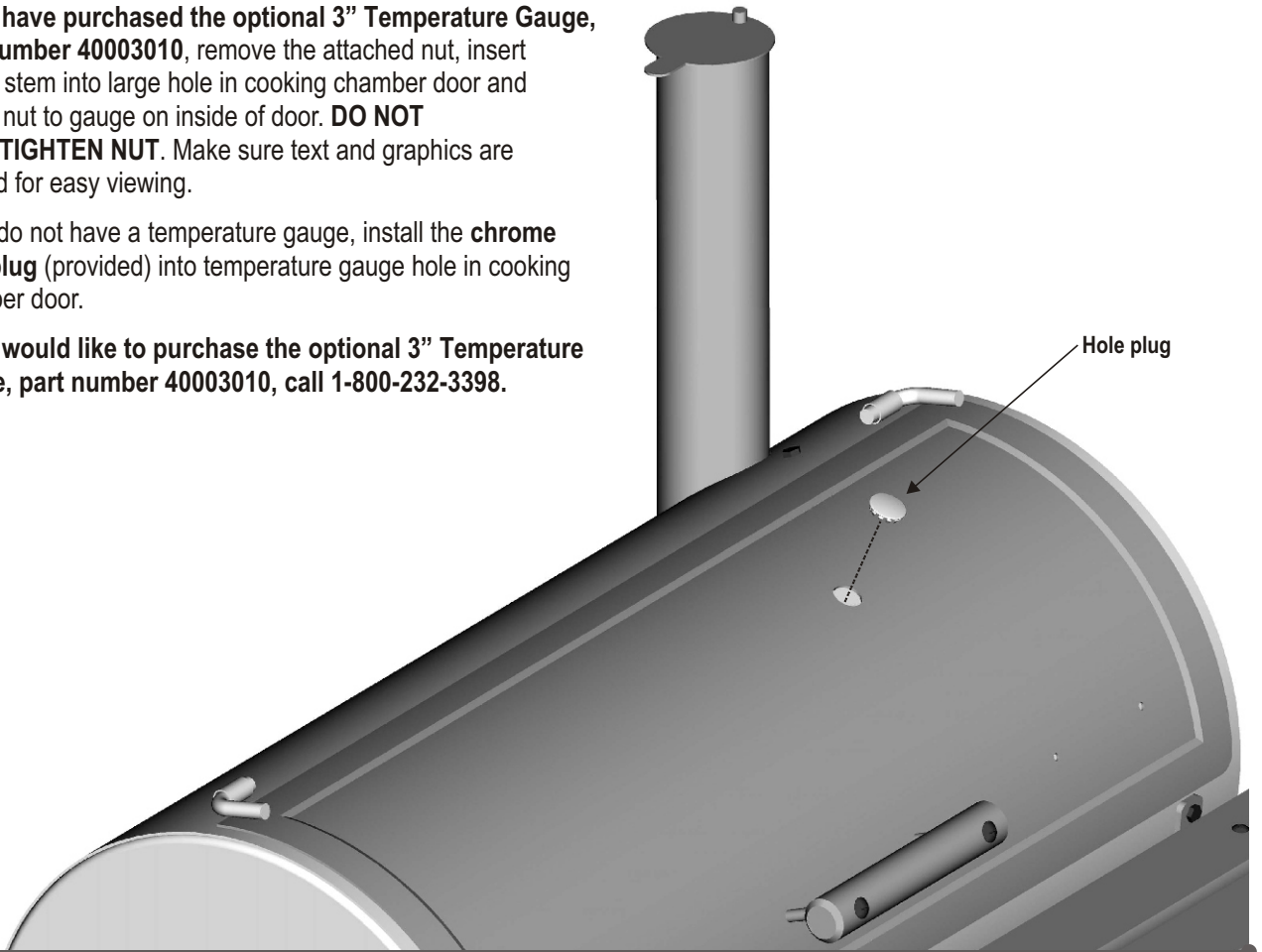

14 Hang grease clip from holes on bottom right side of smoker chamber. A 12 oz. soup or vegetable can will fit nicely into clip to collect grease.

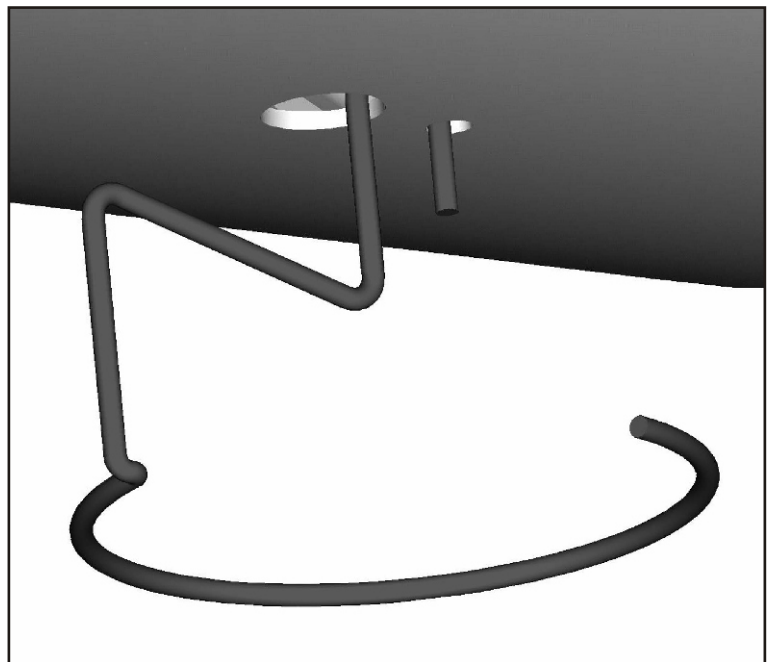
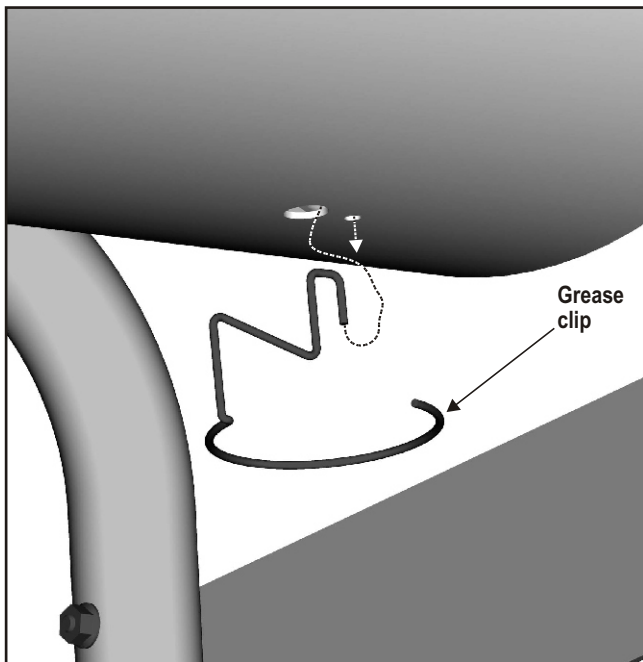

- 15** If logo plate is not already installed, insert logo plate pins into two holes in lower right corner of smoker chamber door. Press **logo plate clips** onto pins until snug against inside of door.

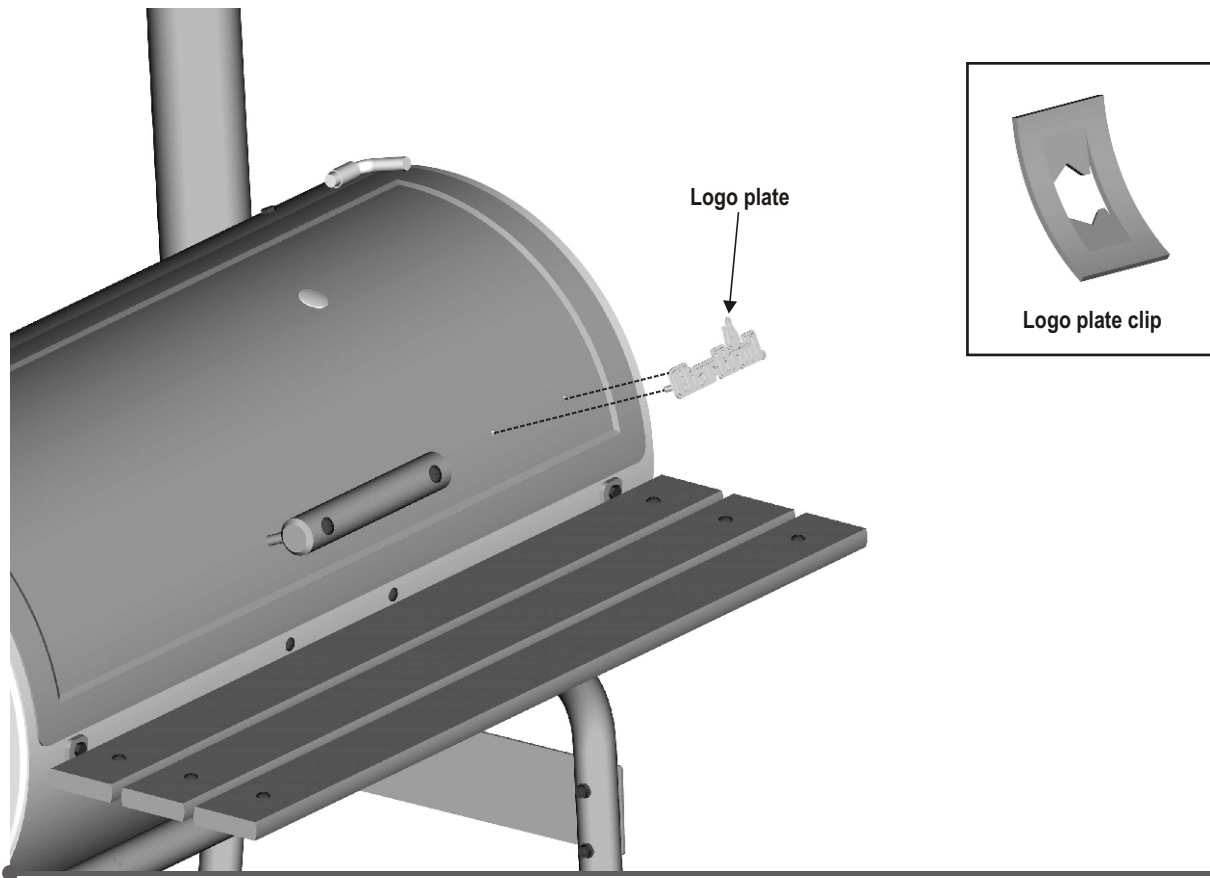

- 16** **NOTE:** Smoker chamber door not pictured for clarity.
If you wish to grill in the smoker chamber, place two of the three wire fire grates into bottom of smoker chamber. Place two large porcelain cooking grates into chamber, resting them on the grate support screws.

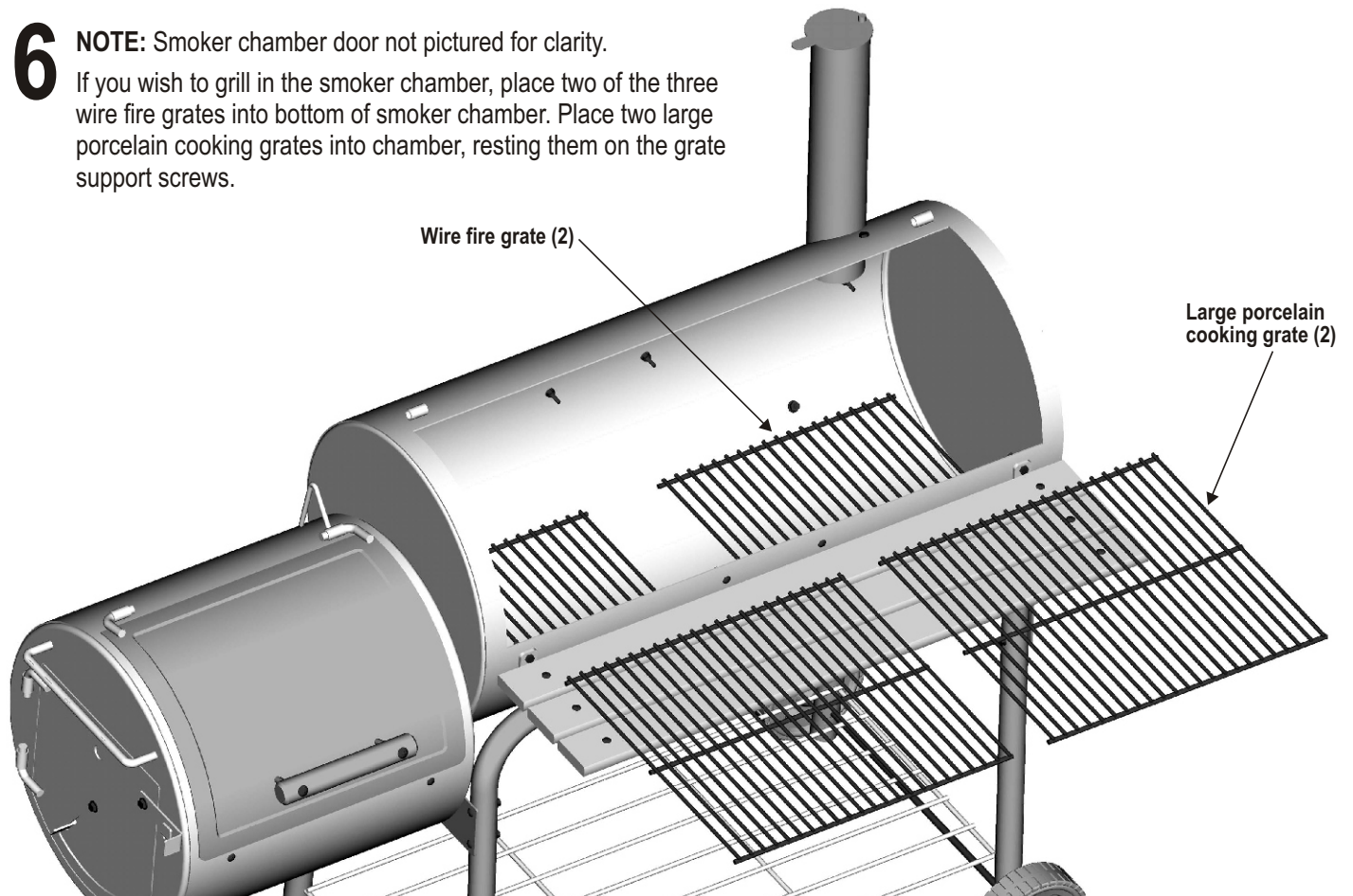

17 Firebox Fire Grate Installation for Smoking or Grilling:

NOTE: Firebox side door not pictured for clarity.

Place remaining wire fire grate into bottom of firebox through side door.

Wire fire grate (1)

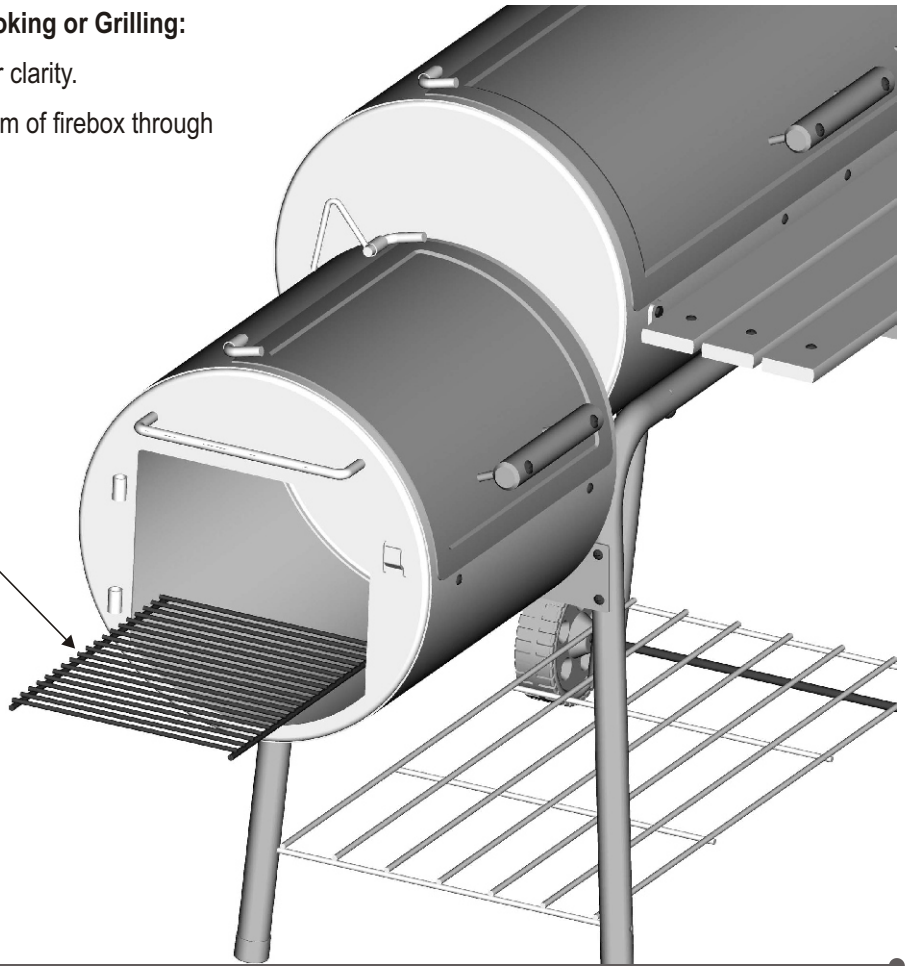

18 Firebox Cooking Grate Installation for Grilling:

NOTE: Firebox door not pictured for clarity.

If you wish to grill in the firebox, install four **#10-24x1" screws** and **#10-24 flange nuts** as grate supports. Insert small porcelain cooking grate into firebox.

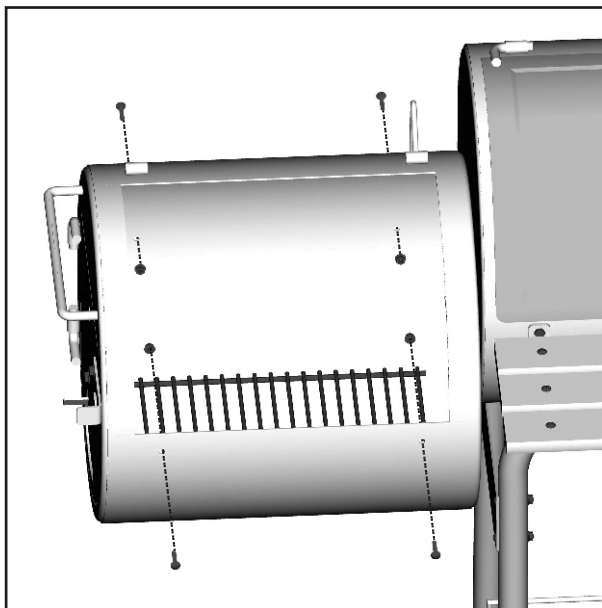

Small porcelain cooking grate (1)

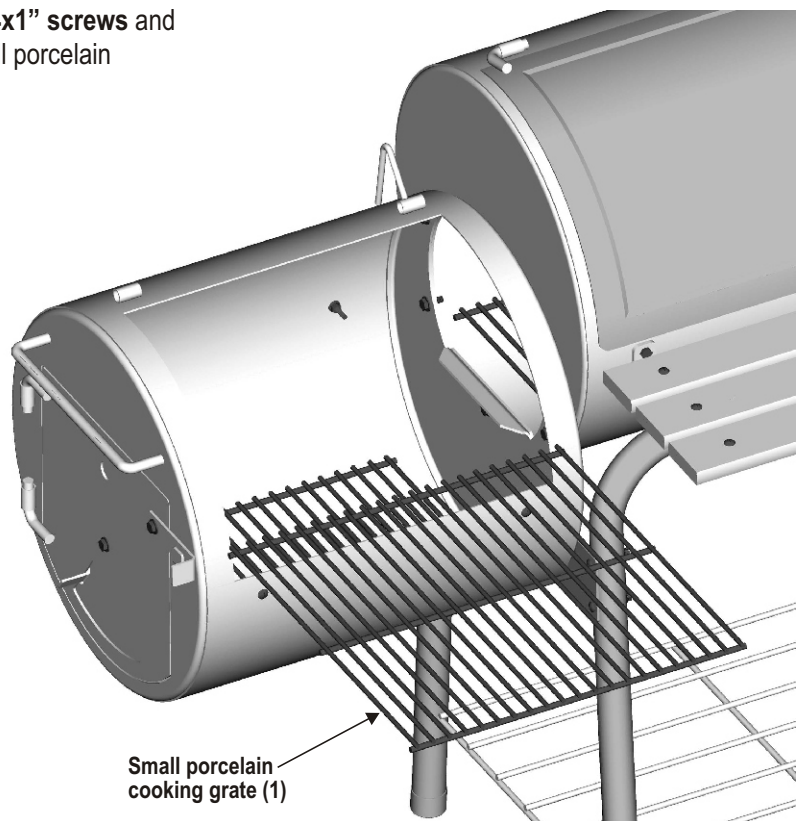

HARDWARE LIST

Hardware is shown actual size. You may have spare hardware after assembly is complete.

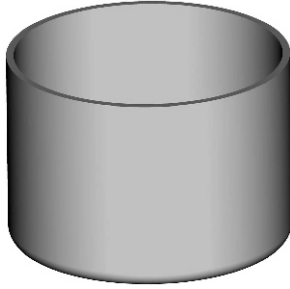

Leg Cap
Qty: 2
(Already installed)



Handle Spacer
Qty: 4



Hole Plug
Qty: 1



Logo Plate Clip
Qty: 2



Cotter Pin
Qty: 2



Flat Washer
Qty: 14
(4 already installed)



1/4-20
Flange Nut
Qty: 18



1/4-20
Hex Nut
Qty: 2
(Already installed)



#10-24
Flange Nut
Qty: 24



#8-32
Lock Nut
Qty: 2

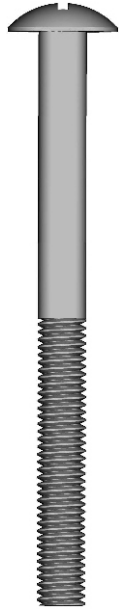

1/4-20x3"
Machine Screw
Qty: 4



1/4-20x2"
Machine Screw
Qty: 4



#10-24x1 1/4"
Machine Screw
Qty: 8



1/4-20x1 1/4"
Hex-Head Bolt
Qty: 2



#10-24x1"
Machine Screw
Qty: 16



1/4-20x3/4"
Hex-Head Bolt
Qty: 10
(2 already installed)



#8-32x1/2"
Machine Screw
Qty: 2



WARNING



**MOST SURFACES ON THIS UNIT ARE HOT WHEN IN USE.
USE EXTREME CAUTION. KEEP OTHERS AWAY FROM UNIT.
ALWAYS WEAR PROTECTIVE CLOTHING TO PREVENT INJURY.**

Preparing and Using Your Silver Smoker

Before cooking with your Silver Smoker, the following steps should be closely followed to both cure the finish and season the interior steel. Failure to properly follow these steps may damage the finish and/or impart metallic flavors to your first foods.

1. Brush all interior surfaces including grills and grates with vegetable cooking oil.
2. Build a small fire on the fire grate, being sure not to lay coals against the walls.
3. Close door. (Position butterfly damper and smokestack damper approximately at one quarter open.) This burn should be sustained for at least two hours, the longer the better. Then, begin increasing temperature by opening the butterfly damper and smokestack damper half-way and adding more charcoal. Your Silver Smoker is now ready for use.

Rust can appear on the inside of your smoker. Maintaining a light coat of vegetable oil on interior surfaces will aid in the protection of your unit. Exterior surfaces of smoker may need occasional touch up. We recommend the use of a commercially available black high temperature spray paint. NEVER PAINT THE INTERIOR OF THE UNIT !

GRILLING

Wood is recommended, however charcoal or a combination of both may be used as the fuel source for grilling, with the fuel source placed and ignited on the fire grate. Do not build too large of a fire. We recommend starting a fire with no more than 4 pounds of charcoal (approximately 60 briquets) and adding more as needed during cooking. After allowing the fire to burn down, place the cooking grills in the smoker. Failure to read and follow instructions for lighting charcoal may result in serious personal injury and/or property damage.

GRILL MAINTENANCE

Frequency of cleanup is determined by how much your smoker is used. Make sure coals are completely extinguished before cleaning inside of smoker. Inside surfaces may be cleaned with a strong solution of detergent and water applied with a scrub brush. Thoroughly rinse with water and allow to air dry before using again.

SMOKING AND SLOW COOKING

If using the Silver Smoker as a smoker or slow cooker, remove the cooking grill from the firebox and build your fire on top of the fire grate in the firebox. Either charcoal or wood may be used, but wood is the recommended fuel for it's rate of burn and the flavor it imparts to the food being cooked. Most seasoned hardwoods are good for smoking such as hickory, mesquite, pecan, oak, and many other fruit woods. The firebox will accommodate most split fireplace size logs (16"). Bark should be avoided or burned off first as it contains a high acid content and imparts an acrid flavor.

After allowing the fire to burn down, close the doors and control the temperature and smoke with the dampers located on the firebox and atop the smokestack. Smoke is contained within the chambers, which will reduce burn while imparting more smoke flavor. Do not operate the Silver Smoker with temperatures exceeding 450 degrees in the smoker chamber. Place the food in the smoker chamber and monitor the temperature. Cooking and smoking are taking place using indirect heat. There is no need to worry about a grease fire flare-up ruining the food. Do not place food within 6" of the opening from the firebox into the smoker chamber. A general rule of thumb for cooking is about 1 hour per pound for smoking large cuts of meat. Refer to a cook book for specific cuts of meats. Limit the number of times you open the smoker chamber door as this will allow heat to escape and extend the cooking time.

HELPFUL HINTS

- If food seems to be getting too smoky or brown before the cooking time is finished, cover it loosely with heavy duty aluminum foil.
- Remove the ash after each use.
- Covered side dishes can be warmed in smoker chamber.
- To prevent flare-ups, brush meat lightly with oil before grilling.
- Keep a small squirt bottle of water handy for grilling flare-ups.

Limited Warranty

Charbroil warrants the Silver Smoker for replacement or repair of parts and/or workmanship for a period of 3 months. Charbroil warrants to the original Silver Smoker owner repair or replacement of the cooking chamber only should "burn out" or "rust through" occur for a period of 1 year. Paint is not warranted and will require touchup.

These limited warranties are made exclusively to the original customer presenting proof of purchase. These warranties are limited to non-commercial usage. Any returned goods must be clearly marked with a Charbroil Return Authorization Number and shipped prepaid. These limited warranties do not cover normal wear and tear or damages resulting from abuse or misuse. This warranty excludes incidental or consequential cost due to damages or losses or property of any nature.

NOTICE: Some states do not allow the exclusion or limitation of incidental or consequential damages or limitations on how long an implied warranty lasts, so the above limitations or exclusions may not apply to you. This warranty gives you specific legal rights and you may also have other legal rights which may vary from state to state.



For warranty service
CALL TOLL FREE
1-800-232-3398