

ETERNUS

ETERNUS DX60 S2 Disk storage system

User's Guide -Site Planning-

This page is intentionally left blank.

Preface

Fujitsu would like to thank you for purchasing our ETERNUS DX60 S2 Disk storage system. The ETERNUS DX60 S2 Disk storage system is designed to be connected to Fujitsu (PRIMEQUEST or PRIMERGY) or non-Fujitsu servers.

This manual describes the environmental requirements that are necessary to install and use the ETERNUS DX60 S2 Disk storage system.

This manual is intended for use of ETERNUS DX60 S2 Disk storage system in regions other than Japan.

Please carefully review the information outlined in this manual.

Fourth Edition
May 2012

Microsoft, Windows, Windows Server, and Internet Explorer are either registered trademarks or trademarks of Microsoft Corporation in the United States and/or other countries.

Mozilla, Firefox, and the Mozilla and Firefox logos are trademarks or registered trademarks of the Mozilla Foundation in the United States and other countries.

The company names, product names and service names mentioned in this document are registered trademarks or trademarks of their respective companies.

About this Manual

Organization

This document is composed of the following four chapters:

- Chapter 1 Hardware Configurations

This chapter describes the main components and the relative optional products that are installed in the ETERNUS DX60 S2 Disk storage system.

- Chapter 2 ETERNUS DX Disk Storage System Installation

This chapter describes the installation specifications, the installation environment, and the power requirements.

- Chapter 3 Connections

This chapter describes the configuration for each interface to connect to the ETERNUS DX60 S2 Disk storage system.

- Chapter 4 Rack and Optional Product Installation

This chapter describes the requirements for rack installation.

This chapter also describes the standard installation rules (installation locations and installation order) of the optional products before shipment from the factory when the optional products are purchased with the ETERNUS DX60 S2 Disk storage system at the same time.

Naming Conventions

- Abbreviations used in this manual

- "ETERNUS DX Disk storage system" refers to the ETERNUS DX60 S2 Disk storage system.
- "Host Bus Adapter (HBA)" refers to the interface module normally used by the server to connect to the ETERNUS DX Disk storage systems.
A "FC card", "LAN card", "Network Interface Card (NIC)", or "SAS card" may be used instead, depending on the server and interface.
- Trademark symbols such as ™ and ® are omitted in this document.

Warning Notations

Warning signs are shown throughout this manual in order to prevent injury to the user and/or material damage. These signs are composed of a symbol and a message describing the recommended level of caution. The following explains the symbol, its level of caution, and its meaning as used in this manual.



This symbol indicates the possibility of minor or moderate personal injury, as well as damage to the ETERNUS DX Disk storage system and/or to other users and their property, if the ETERNUS DX Disk storage system is not used properly.

How Warnings are Presented in this Manual

A message is written beside the symbol indicating the caution level. This message is marked with a vertical ribbon in the left margin, to distinguish this warning from ordinary descriptions. An example is shown here.

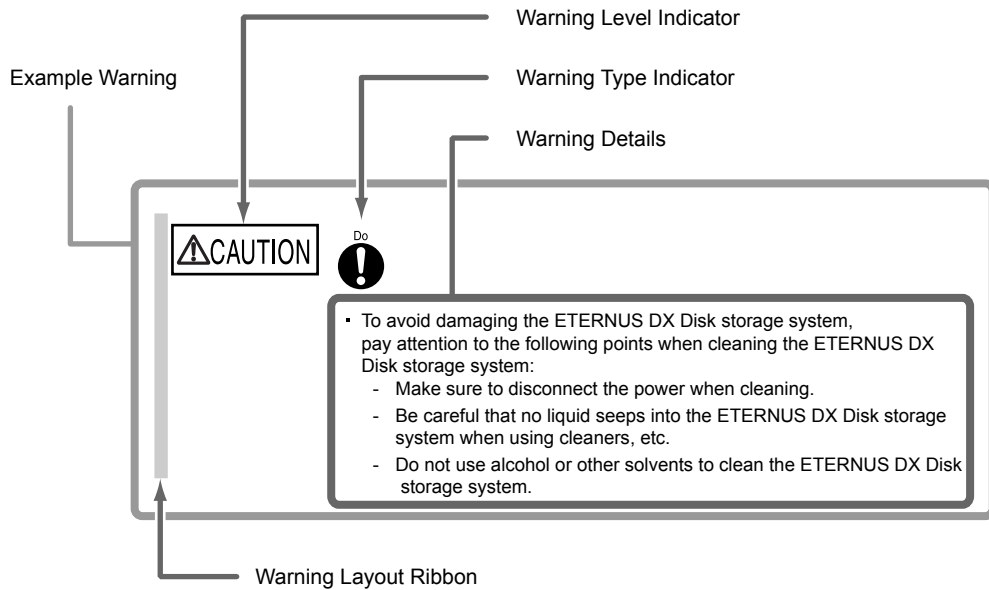

Table of Contents

Chapter 1	Hardware Configurations	11
1.1	Controller Enclosure	11
1.1.1	Controllers	15
1.1.2	Power Supply Units	18
1.2	Drive Enclosures	18
1.2.1	Expanders	20
1.2.2	Power Supply Units	20
1.3	Enclosure Connection Path	21
1.4	Disks	22
1.4.1	2.5" Disks	22
1.4.2	3.5" Disks	22
1.5	Power Distribution Units (Only for Regions Other than EMEA&I)	23
Chapter 2	ETERNUS DX Disk Storage System Installation	26
2.1	Installation Specifications	26
2.1.1	ETERNUS DX60 S2	26
2.2	Package Size	28
2.3	Installation Area	29
2.4	Installation Environment	30
2.4.1	Air Conditioning	30
2.4.2	Earthquake Resistance	30
2.4.3	Load Bearing Capacity for Floors	31
2.5	Outlet/Socket Specifications	31
2.5.1	Specifications for Optional Power Supply Products	31
2.5.2	Required Number of Outlets/Sockets	34
2.6	Circuit Protectors	36
2.6.1	Required Conditions	36
2.6.2	Breaking Characteristics	37
Chapter 3	Connections.....	41
3.1	Host Connections	41
3.1.1	Host Interfaces	41
3.1.2	Host Connection Path	42
3.2	LAN Connection	45
3.3	Power Supply Connection	46
3.3.1	Input Power Supply Lines	46
3.3.2	UPS Connection	48
3.4	Power Synchronized Connections	49

Chapter 4	Rack and Optional Product Installation	53
4.1	Rack Installation Requirements	53
4.2	Installable Racks	54
4.2.1	Fujitsu Racks	54
4.2.2	Non-Fujitsu Racks	54
4.3	Standard Installation Rules Before Shipment (Only for Regions Other than EMEA&I)	56
4.3.1	Drive Enclosures	56
4.3.2	Disks	57
4.3.3	Disk Installation Examples	59

List of Figures

Figure 1.1	Front view of a 2.5" type controller enclosure.....	11
Figure 1.2	Rear view of a 2.5" type controller enclosure (single-controller type).....	12
Figure 1.3	Rear view of a 2.5" type controller enclosure (dual-controller type).....	12
Figure 1.4	Top view of a 2.5" type controller enclosure.....	13
Figure 1.5	Side view of a 2.5" type controller enclosure.....	13
Figure 1.6	Front view of a 3.5" type controller enclosure (with front cover).....	13
Figure 1.7	Front view of a 3.5" type controller enclosure (without front cover).....	13
Figure 1.8	Rear view of a 3.5" type controller enclosure (single-controller type).....	14
Figure 1.9	Rear view of a 3.5" type controller enclosure (dual-controller type).....	14
Figure 1.10	Top view of a 3.5" type controller enclosure.....	15
Figure 1.11	Side view of a 3.5" type controller enclosure.....	15
Figure 1.12	Host interface port (FC model).....	16
Figure 1.13	Host interface port (iSCSI model).....	16
Figure 1.14	Host interface port (SAS model).....	16
Figure 1.15	Power supply unit (controller enclosure).....	18
Figure 1.16	Front view of a drive enclosure (with front cover).....	18
Figure 1.17	Front view of a drive enclosure (without front cover).....	18
Figure 1.18	Rear view of a drive enclosure (single-expander type).....	19
Figure 1.19	Rear view of a drive enclosure (dual-expander type).....	19
Figure 1.20	Top view of a drive enclosure.....	19
Figure 1.21	Side view of a drive enclosure.....	20
Figure 1.22	Expander (drive enclosure).....	20
Figure 1.23	Power supply unit (drive enclosure).....	20
Figure 1.24	Enclosure connection path (dual-controller type).....	21
Figure 1.25	Enclosure connection path (single-controller type).....	21
Figure 1.26	Power distribution unit (AC200-240V, 1U, Max 2 enclosures connection).....	23
Figure 1.27	Power distribution unit (AC200-240V, 2U, Max 6 enclosures connection).....	24
Figure 1.28	Power distribution unit (AC200-240V, 2U, Max 8 enclosures connection).....	24
Figure 2.1	Installation area and service area.....	29
Figure 2.2	Power distribution unit (1U).....	35
Figure 2.3	Power distribution unit (2U).....	35
Figure 2.4	Power distribution unit (2U) breaking characteristics (graph).....	37
Figure 2.5	Example of a power supply connection using a power distribution unit (2U).....	38
Figure 2.6	Power distribution unit (1U) breaking characteristics (graph).....	38
Figure 2.7	Example of a power supply connection using a power distribution unit (1U).....	39
Figure 2.8	ETERNUS DX Disk storage system (PSU) breaking characteristics (graph).....	40
Figure 2.9	Example of a power supply connection without power distribution units.....	40
Figure 3.1	Single path connection (direct connection).....	43
Figure 3.2	Single path connection (switch connection).....	43
Figure 3.3	Multipath connection (direct connection).....	44
Figure 3.4	Multipath connection (switch connection).....	44
Figure 3.5	Example of a LAN connection.....	45
Figure 3.6	Dual-line power supply when connecting to power sockets.....	46
Figure 3.7	Dual-line power supply when connecting to UPS units.....	47
Figure 3.8	Single-line power supply when connecting to power sockets.....	47
Figure 3.9	Single-line power supply when connecting to a UPS unit.....	47
Figure 3.10	Single-line power supply when connecting to a power socket and a UPS unit.....	47
Figure 3.11	Power control using a power synchronized unit (when connecting one or two servers).....	50

Figure 3.12	Power control using a power synchronized unit (when connecting three or more servers)	51
Figure 4.1	Unit installation area	55
Figure 4.2	Installation diagram for 2.5" disks.....	58
Figure 4.3	Installation diagram for 3.5" disks.....	59
Figure 4.4	Disk installation example at shipment (2.5" type controller enclosure).....	60
Figure 4.5	Disk installation example at shipment (3.5" type controller enclosure).....	60

List of Tables

Table 1.1	Host interface port specifications.....	16
Table 1.2	DI port specifications	17
Table 1.3	LAN port specifications.....	17
Table 1.4	PWC port specifications	17
Table 1.5	DI port specifications	20
Table 1.6	2.5" disk specifications	22
Table 1.7	3.5" disk specifications	22
Table 1.8	Power distribution unit (AC200-240V, 1U, Max 2 enclosures connection) and provided AC cable specifications.....	23
Table 1.9	Power distribution unit (AC200-240V, 2U, Max 6 enclosures connection) and provided AC cable specifications.....	24
Table 1.10	Power distribution unit (AC200-240V, 2U, Max 8 enclosures connection) and provided AC cable specifications.....	25
Table 2.1	ETERNUS DX60 S2 installation specifications	26
Table 2.2	Package size (for regions other than EMEA&I).....	28
Table 2.3	Specifications for power cords supplied with the ETERNUS DX Disk storage system (for the EMEA&I region)	32
Table 2.4	Specifications for power cords supplied with the ETERNUS DX Disk storage system (for regions other than EMEA&I)	32
Table 2.5	Specifications for power distribution unit for DX60 S2 (AC200-240V, 1U, Max 2 enclosures connection).....	33
Table 2.6	Specifications for power distribution unit for DX60 S2 (AC200-240V, 2U, Max 6 enclosures connection).....	33
Table 2.7	Specifications for power distribution unit for DX60 S2 (AC200-240V, 2U, Max 8 enclosures connection).....	33
Table 2.8	Required number of outlets and sockets to install power distribution units	34
Table 2.9	Required conditions for distribution board circuit protectors.....	36
Table 2.10	Power distribution unit (2U) breaking characteristics (Trip time (sec.))	37
Table 2.11	Power distribution unit (1U) breaking characteristics (Trip time (sec.))	39
Table 2.12	ETERNUS DX Disk storage system (PSU) breaking characteristics (Trip time (sec.))	40
Table 3.1	Ethernet frame capacity (Jumbo Frame settings).....	42
Table 3.2	ETERNUS Web GUI operating environment.....	45
Table 4.1	Enclosure installation order	53
Table 4.2	Specifications for the unit installation area	55
Table 4.3	Priority order of 2.5" disk installation	57
Table 4.4	Priority order of 3.5" disk installation	58

Chapter 1 Hardware Configurations

This chapter explains hardware configurations for the ETERNUS DX Disk storage system.

1.1 Controller Enclosure

This section explains the main components in the controller enclosure.

The controller enclosure contains disks installed in the front, and controllers and power supply units in the rear.

Since the power supply units are redundant, operations can continue even if one of them fails. There are two models: a single-controller type and a dual-controller type. For a dual-controller type, operations can continue even if one of the controllers fails.

IMPORTANT

- The single-controller type differs from the dual-controller type by the following features:
 - The controller and expander are not duplicated.
 - Hot maintenance or swapping of the controller and expander is not possible.
 - Concurrent firmware loading or update of the controller firmware and expander firmware is not possible.
 - Multipath connection to a single server is not available.
- Fujitsu recommends that the dual-controller types, in which the controller and expander are duplicated, be used in a system where a high level of reliability is required.

■ External views of a 2.5" type controller enclosure

● Front view

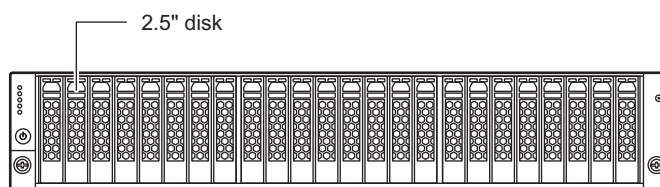

Figure 1.1 Front view of a 2.5" type controller enclosure

- Rear view
 - Single-controller type

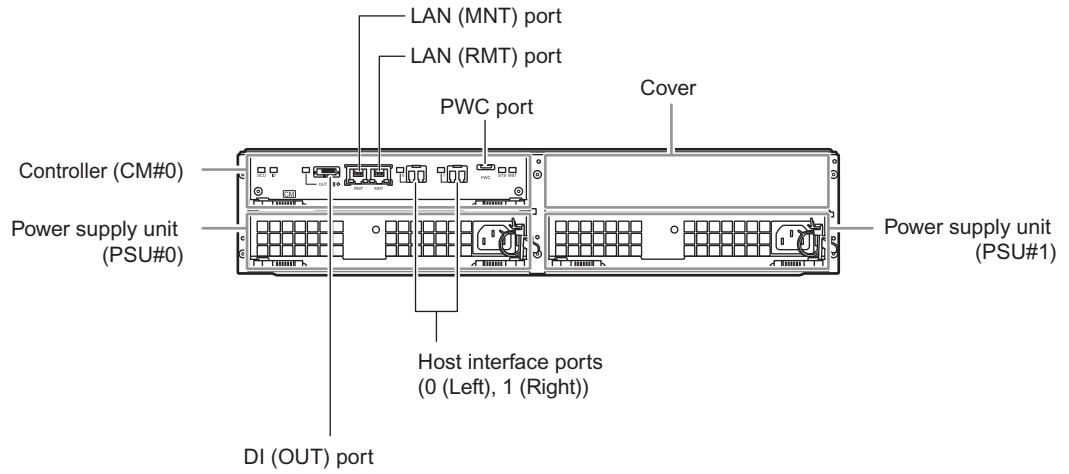

Figure 1.2 Rear view of a 2.5" type controller enclosure (single-controller type)

- Dual-controller type

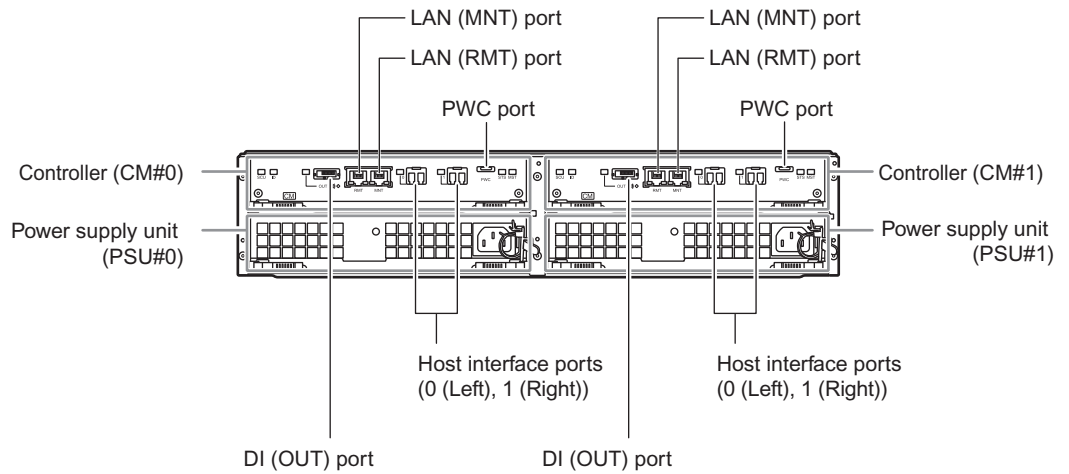

Figure 1.3 Rear view of a 2.5" type controller enclosure (dual-controller type)

● Top view

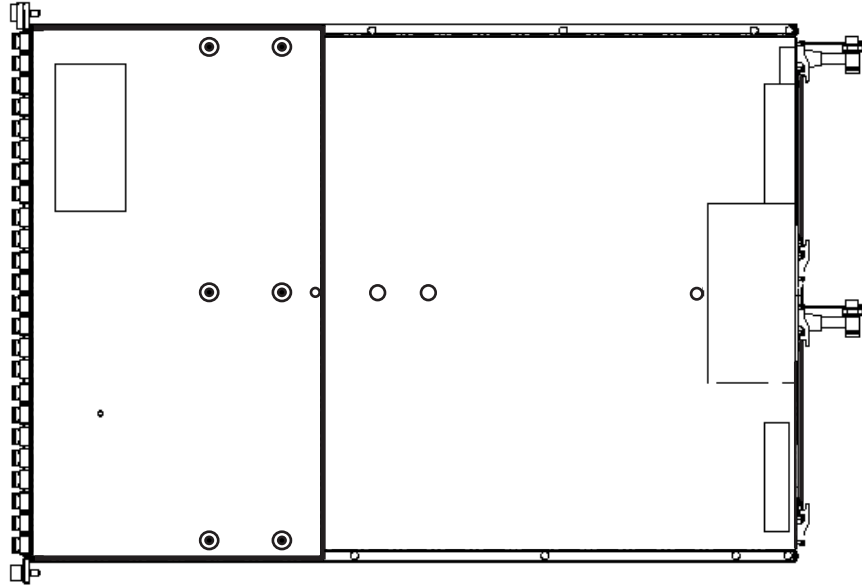

Figure 1.4 Top view of a 2.5" type controller enclosure

● Side view



Figure 1.5 Side view of a 2.5" type controller enclosure

■ External views of a 3.5" type controller enclosure

● Front view

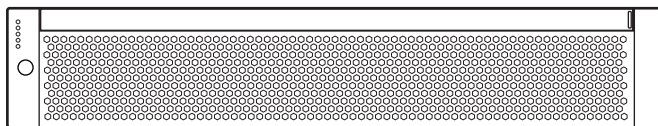

Figure 1.6 Front view of a 3.5" type controller enclosure (with front cover)

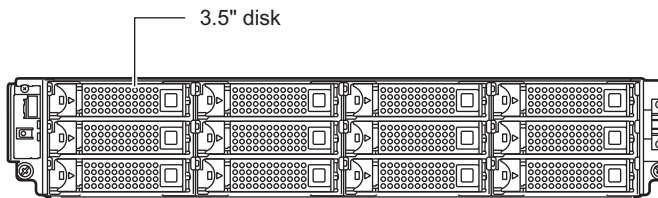

Figure 1.7 Front view of a 3.5" type controller enclosure (without front cover)

- Rear view
 - Single-controller type

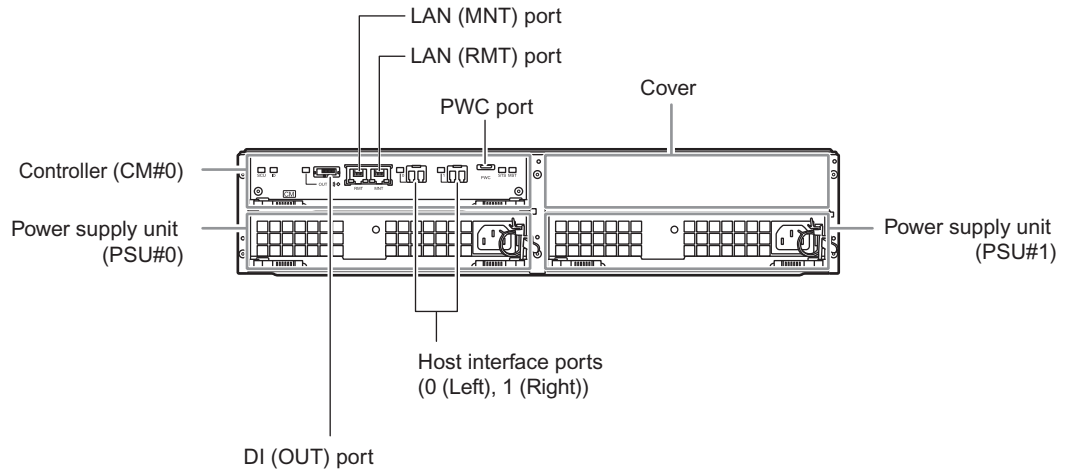

Figure 1.8 Rear view of a 3.5" type controller enclosure (single-controller type)

- Dual-controller type

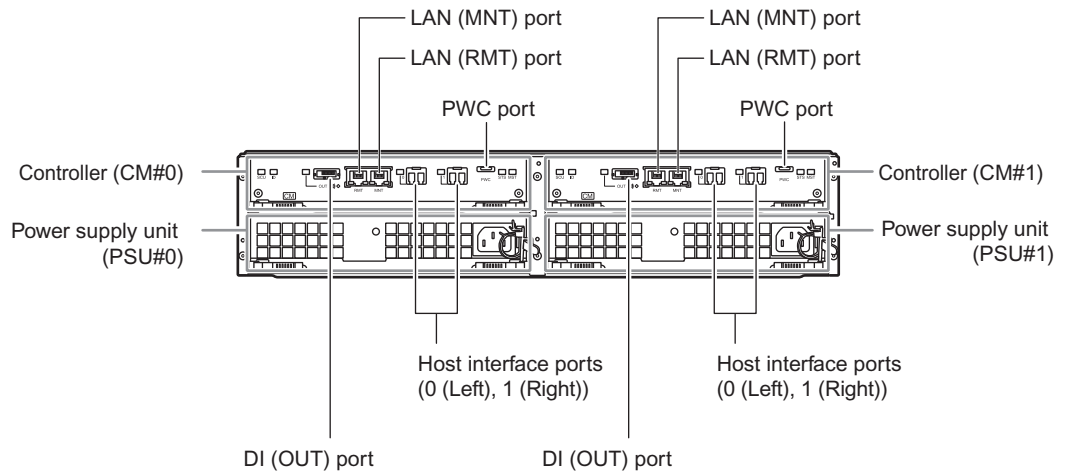

Figure 1.9 Rear view of a 3.5" type controller enclosure (dual-controller type)

● Top view

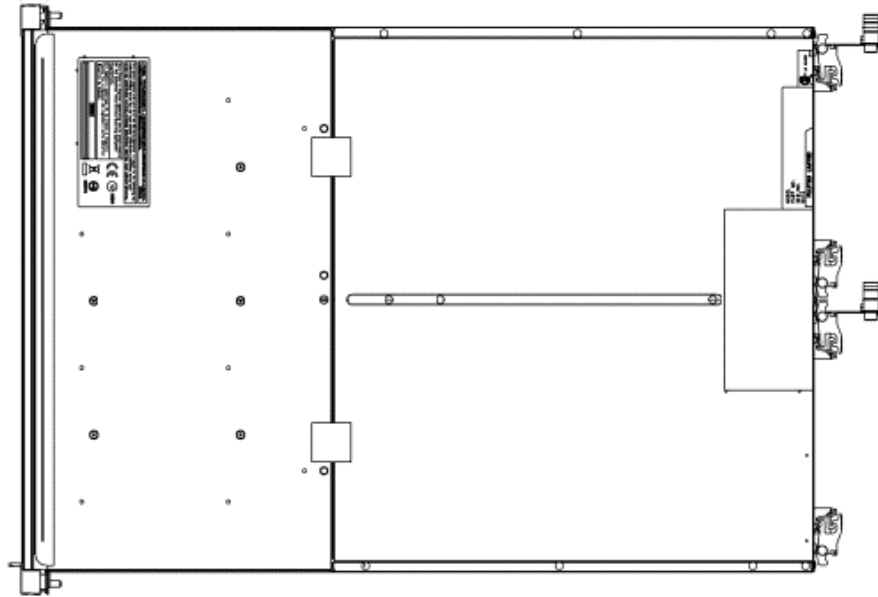

Figure 1.10 Top view of a 3.5" type controller enclosure

● Side view

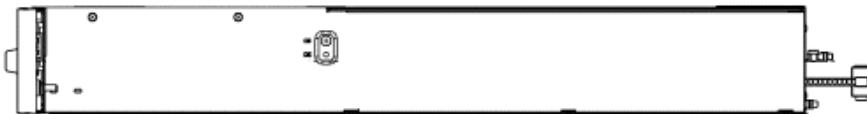

Figure 1.11 Side view of a 3.5" type controller enclosure

1.1.1 Controllers

The controller contains a CPU, cache memory, System Capacitor Unit (SCU), non-volatile memory, host interface ports, drive interface (DI) ports, and LAN ports. The controller controls all operations in the ETERNUS DX Disk storage system.

■ Cache memory

Cache memory enables high speed processing by storing frequently used data. The cache memory capacity for each controller is 1GB.

■ Host interface ports

Host interface ports are used to connect controllers to servers.
 Two host interface ports can be installed in the controller of an ETERNUS DX Disk storage system.
 FC, iSCSI, and SAS are available as host interface.

● FC model

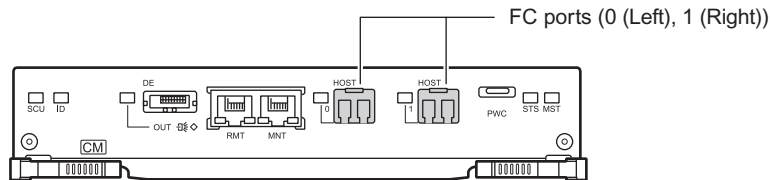

Figure 1.12 Host interface port (FC model)

● iSCSI model

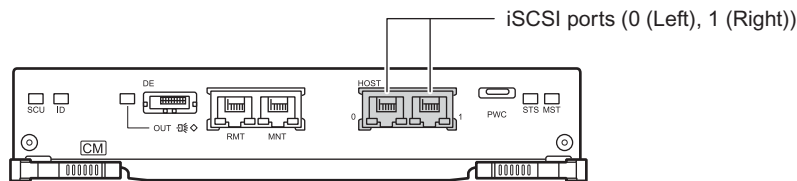

Figure 1.13 Host interface port (iSCSI model)

● SAS model

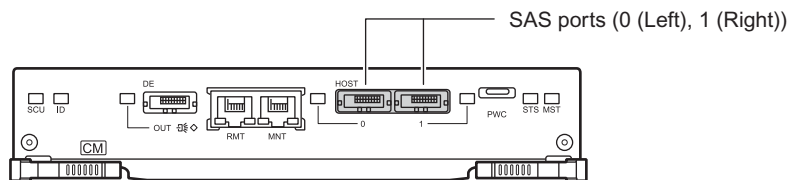

Figure 1.14 Host interface port (SAS model)

The following table shows the host interface port specifications.

Table 1.1 Host interface port specifications

Interface	Transfer speed (max.)	Connector type	Number of ports for each controller
FC	4Gbit/s	SFP	2
iSCSI	1Gbit/s	RJ-45	2
SAS	3Gbit/s	miniSAS (SFF8088)	2

■ Drive interface ports

A DI port is used to connect a drive enclosure.
The following table shows the DI port specifications.

Table 1.2 DI port specifications

Interface	Transfer speed (max.)	Connector type	Number of ports for each controller
SAS	3Gbit/s	miniSAS (SFF8088)	1

■ LAN ports

Two LAN ports (RJ-45) are installed in each controller.

● Regions other than EMEA&I

Each LAN port is used for operation management (MNT port) and for remote support function (RMT port) respectively.

● EMEA&I region

The MNT port is used for operation management and the RMT port is used for maintenance.

The following table shows the LAN port specifications.

Table 1.3 LAN port specifications

Interface	Transfer speed (max.)	Connector type	Number of ports for each controller
Ethernet (1000Base-T/100Base-TX/10Base-T)	1Gbit/s	RJ-45	2

■ SCU

A System Capacitor Unit (SCU) is installed in a controller as a backup power source in case of power outage.

The SCU is charged from an external power source while the ETERNUS DX Disk storage system is running normally. If a power failure is detected, data in the cache memory is saved to the non-volatile memory in the controller using the SCU. There is no limit to the post-failure data retention time.

■ PWC ports

A PWC port is installed in a controller.

The PWC port is used to connect a power synchronized unit to perform power synchronization.

The following table shows the PWC port specifications.

Table 1.4 PWC port specifications

Interface	Connector type	Number of ports for each controller
RS232C	D-sub9 pin	1

1.1.2 Power Supply Units

The power supply unit transforms input AC power from a power socket to DC power and supplies power to each component. Two power supply units are installed in each controller enclosure. Each power supply unit contains fans.

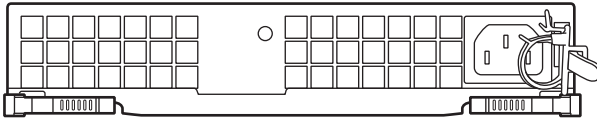

Figure 1.15 Power supply unit (controller enclosure)

1.2 Drive Enclosures

This section explains the main components in the drive enclosure. The drive enclosure contains disks installed in the front, and expanders and power supply units in the rear.

Up to 12 disks can be installed in a 3.5" type drive enclosure.

Since the power supply units are redundant, operations can continue even if one of them fails.

■ Drive enclosure

● Front view

- With front cover

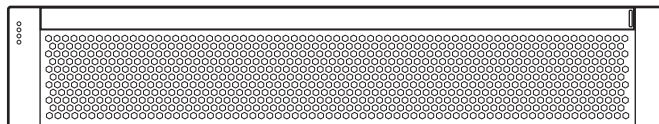

Figure 1.16 Front view of a drive enclosure (with front cover)

- Without front cover

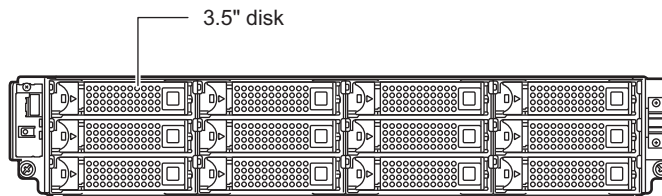

Figure 1.17 Front view of a drive enclosure (without front cover)

- Rear view
 - Single-expander type

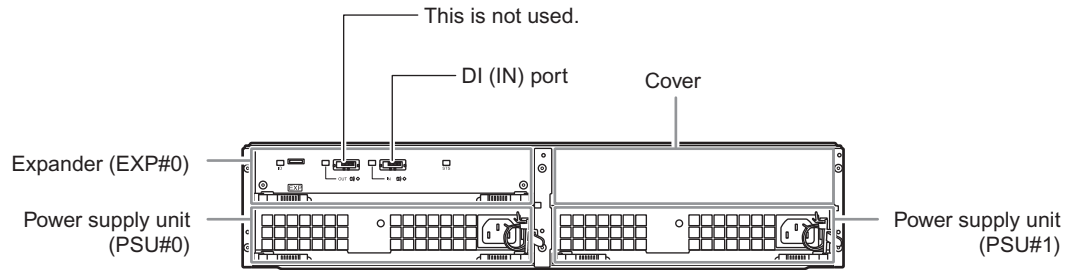

Figure 1.18 Rear view of a drive enclosure (single-expander type)

- Dual-expander type

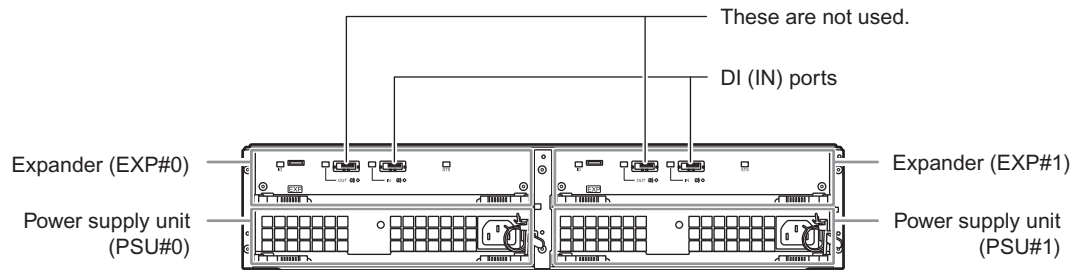

Figure 1.19 Rear view of a drive enclosure (dual-expander type)

- Top view

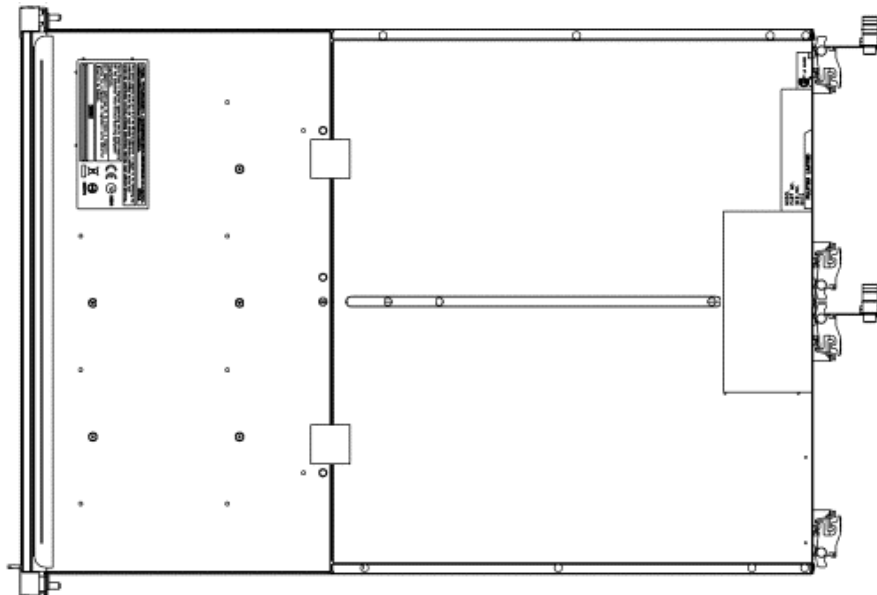

Figure 1.20 Top view of a drive enclosure

● Side view



Figure 1.21 Side view of a drive enclosure

1.2.1 Expanders

The expander is a component that controls the interaction between the controller and the disks.

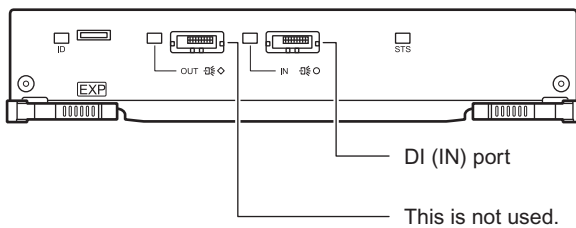

Figure 1.22 Expander (drive enclosure)

■ Drive interface ports

A DI port is used to connect a controller enclosure. The following table shows the DI port specifications.

Table 1.5 DI port specifications

Interface	Transfer speed (max.)	Connector type	Number of ports for each expander
SAS	3Gbit/s	miniSAS (SFF8088)	1 (IN)

1.2.2 Power Supply Units

The power supply unit transforms input AC power from a power socket to DC power and supplies power to each component. Two power supply units are installed in each drive enclosure. Each power supply unit contains fans.

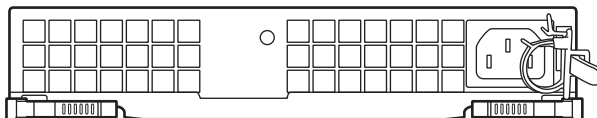

Figure 1.23 Power supply unit (drive enclosure)

1.3 Enclosure Connection Path

For a dual-controller type, a controller enclosure (CE) is connected to a drive enclosure (DE) with multiple paths.

A drive enclosure has two independent DI ports. Path redundancy is maintained by connecting the drive enclosure to two controllers directly. This configuration allows operation to continue even if one of the connection paths fails.

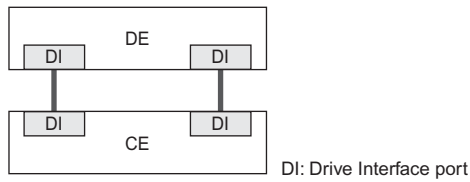

Figure 1.24 Enclosure connection path (dual-controller type)

A connection path is not duplicated in a single-controller type.

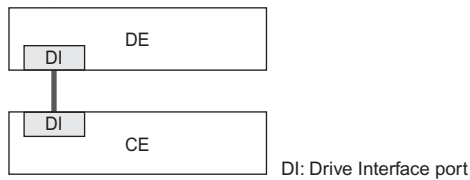

Figure 1.25 Enclosure connection path (single-controller type)

1.4 Disks

The following disks can be installed in a controller enclosure and drive enclosure.

1.4.1 2.5" Disks

The following table shows the 2.5" disk specifications.

Table 1.6 2.5" disk specifications

Disk name	DI	Storage media	Storage capacity	Speed
SAS disks	Serial Attached SCSI (3Gbit/s)	Hard disk	300GB, 450GB, 600GB, 900GB	10,000rpm
Nearline SAS disks		Hard disk	1TB	7,200rpm

1.4.2 3.5" Disks

The following table shows the 3.5" disk specifications.

Table 1.7 3.5" disk specifications

Disk name	DI	Storage media	Storage capacity	Speed
SAS disks	Serial Attached SCSI (3Gbit/s)	Hard disk	300GB, 450GB, 600GB	15,000rpm
Nearline SAS disks		Hard disk	1TB, 2TB, 3TB	7,200rpm

1.5 Power Distribution Units (Only for Regions Other than EMEA&I)

There are two sizes for power distribution units: 1U and 2U.
 A power distribution unit is an option to connect power supply units to power outlets when power sockets are limited.

■ Power distribution unit for DX60 S2 (AC200-240V, 1U, Max 2 enclosures connection)

There are four outlets and two inlets.

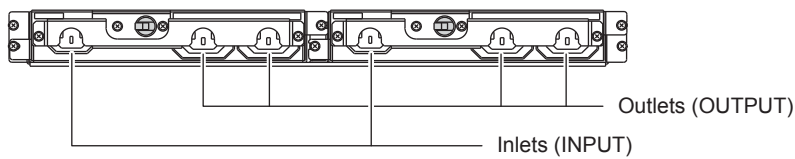

Figure 1.26 Power distribution unit (AC200-240V, 1U, Max 2 enclosures connection)

The following table shows the specifications of a power distribution unit and the AC cables that are provided.

Table 1.8 Power distribution unit (AC200-240V, 1U, Max 2 enclosures connection) and provided AC cable specifications

Item		Specifications
Power	Voltage	AC200 - 240V
	Phase	Single
	Frequency	50Hz/60Hz
Input cable	Connection type	IEC60320-C13 ↔ NEMA L6-15P
	Length	4m
	Quantity	2
Output cable	Connection type	IEC60320-C13 ↔ IEC60320-C14
	Length	3m
	Quantity	4

■ Power distribution unit for DX60 S2 (AC200-240V, 2U, Max 6 enclosures connection)

There are 12 outlets.

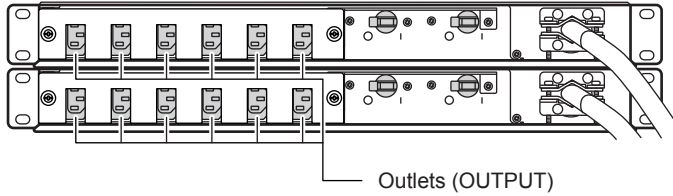

Figure 1.27 Power distribution unit (AC200-240V, 2U, Max 6 enclosures connection)

The following table shows the specifications of a power distribution unit and the AC cables that are provided.

Table 1.9 Power distribution unit (AC200-240V, 2U, Max 6 enclosures connection) and provided AC cable specifications

Item		Specifications
Power	Voltage	AC200 - 240V
	Phase	Single
	Frequency	50Hz/60Hz
Input cable	Connection type	Straight-through ↔ NEMA L6-20P
	Length	4m
	Quantity	2
Output cable	Connection type	IEC60320-C13 ↔ IEC60320-C14
	Length	3m
	Quantity	12

■ Power distribution unit for DX60 S2 (AC200-240V, 2U, Max 8 enclosures connection)

There are 16 outlets.

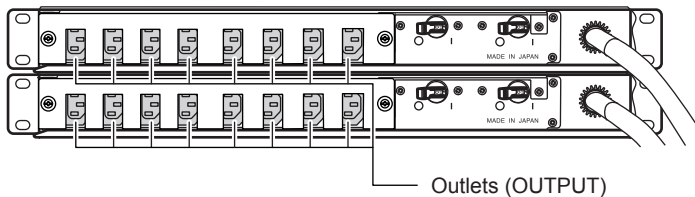

Figure 1.28 Power distribution unit (AC200-240V, 2U, Max 8 enclosures connection)

The following table shows the specifications of a power distribution unit and the AC cables that are provided.

Table 1.10 Power distribution unit (AC200-240V, 2U, Max 8 enclosures connection) and provided AC cable specifications

Item		Specifications
Power	Voltage	AC200 - 240V
	Phase	Single
	Frequency	50Hz/60Hz
Input cable	Connection type	Straight-through ↔ NEMA L6-30P
	Length	4m
	Quantity	2
Output cable	Connection type	IEC60320-C13 ↔ IEC60320-C14
	Length	3m
	Quantity	16

Chapter 2 ETERNUS DX Disk Storage System Installation

This chapter explains the installation of the ETERNUS DX Disk storage system.

2.1 Installation Specifications

2.1.1 ETERNUS DX60 S2

The following table shows the specifications of the ETERNUS DX60 S2.

Table 2.1 ETERNUS DX60 S2 installation specifications

Item		ETERNUS DX60 S2		
		2.5" disk configuration	3.5" disk configuration	
Dimensions (W × D × H)	Controller enclosure		483 × 650 × 88mm (2U)	483 × 650 × 88mm (2U)
	Drive enclosure		—	483 × 650 × 88mm (2U)
	Power distribution unit	1U	435 × 148 × 38mm	
2U		(485 × 280 × 43mm) × 2 (*1)		
Maximum weight (*2)	Controller enclosure		35kg	
	Drive enclosure		35kg	
	Power distribution unit	1U	2kg	
2U		(6kg) × 2 (*1)		
Service area		Front: 800mm, Rear: 800mm		
Power	Voltage		AC 100 – 120V, AC 200 – 240V	
	Phase		Single	
	Frequency		50Hz/60Hz	
	Number of power supply units		2 (for each enclosure)	
	Plug type	EMEA&I region		For AC200V connections: IEC60320-C14G (supplied as standard)
Regions other than EMEA&I		For AC200V connections: NEMA L6-15P (supplied as standard) For AC100V/AC200V connections: IEC60320-C14 (optional)		

Item			ETERNUS DX60 S2	
			2.5" disk configuration	3.5" disk configuration
Maximum power requirements (*2)	Controller enclosure	AC 100 – 120V	510W (520VA)	440W (450VA)
		AC 200 – 240V	500W (510VA)	430W (440VA)
	Drive enclosure	AC 100 – 120V	—	370W (380VA)
		AC 200 – 240V	—	370W (380VA)
Maximum heat generation (*2)	Controller enclosure	AC 100 – 120V	1,840kJ/h	1,590kJ/h
		AC 200 – 240V	1,800kJ/h	1,550kJ/h
	Drive enclosure	AC 100 – 120V	—	1,340kJ/h
		AC 200 – 240V	—	1,340kJ/h
Maximum amount of exhaust air	Controller enclosure		2.9m ³ /min	
	Drive enclosure		2.9m ³ /min	
Environmental conditions	Temperature	Operating	10 – 40°C	
		Not operating	0 – 50°C	
		Shipping	-40 – 60°C	
	Temperature gradient		15°C/Hr or less	
	Humidity	Operating	20 – 80%RH	
		Not operating	8 – 80%RH	
		Shipping	8 – 90%RH	
	Humidity gradient		30%/day or less	
	Maximum wet bulb temperature		29°C	
	Altitude above sea level		0 – 3,000m	
	Air borne dust		0.15mg/m ³ or less	
	Gas concentration tolerance level		Cl ₂ : 3.4ppb or less, H ₂ S: 7.1ppb or less SO ₂ : 37ppb or less, NH ₃ : 420ppb or less NO ₂ : 52ppb or less, O ₃ : 5ppb or less HCl: 6.6ppb or less, HF: 3.6ppb or less	
	Oil vapor		0.2mg/m ³ or less	
Seawater (salt corrosion)		If the ETERNUS DX Disk storage system is installed on the ocean or premises within 0.5km from the coast, necessary measures must be taken to prevent salt corrosion.		
Vibration limit	Operating		400gal	
	Not operating		1,000gal	
Noise emission (*3)	Sound Pressure Level (LpAm)		43.5dB(A)	42.0dB(A)
	Sound Power Level (LWAd)		6.0B	5.9B

*1: A 2U power distribution unit is composed of two 1U power distribution units.

*2: These values are for when the controller enclosure has twenty-four disks in a 2.5" disk configuration or when each enclosure has twelve disks in a 3.5" disk configuration.

*3: These values are measured when a single controller enclosure is configured in an environment in which the temperature is 23 ± 2°C.

2.2 Package Size

The ETERNUS DX Disk storage system is shipped in cardboard boxes. These boxes may not fit through some doorways or elevators. To make sure that the ETERNUS DX Disk storage system can be moved to the installation site, carefully check the transport route information. Refer to ["2.1 Installation Specifications" \(page 26\)](#) for the maximum weight of each enclosure. The following table shows the package size and the maximum package weight of each component for regions other than EMEA&I.

Table 2.2 Package size (for regions other than EMEA&I)

Component		Package size (W × D × H)	Maximum weight
Controller enclosure	2.5" type	610 × 840 × 250mm	40kg
	3.5" type	610 × 840 × 250mm	40kg
Drive enclosure	3.5" type	610 × 840 × 250mm	40kg
Disk (*1)	2.5"	196 × 236 × 124mm	0.6kg
	3.5"	225 × 305 × 135mm	1.1kg
Power distribution unit	1U	570 × 710 × 160mm	4kg
	2U	(390 × 590 × 180mm) × 2	(7kg) × 2

*1: When an order for optional disks to be installed in the factory is placed, enclosures are shipped with the disks preinstalled. When optional disks are ordered without preinstallation, each disk is shipped in an individual package.

2.3 Installation Area

This section explains the installation area and the service area that are required for an ETERNUS DX Disk storage system that is installed in a Fujitsu 19-inch rack.

Secure service areas that are 800mm or more in the front and rear of the ETERNUS DX Disk storage system. The size of the side areas varies depending on the rack specifications.

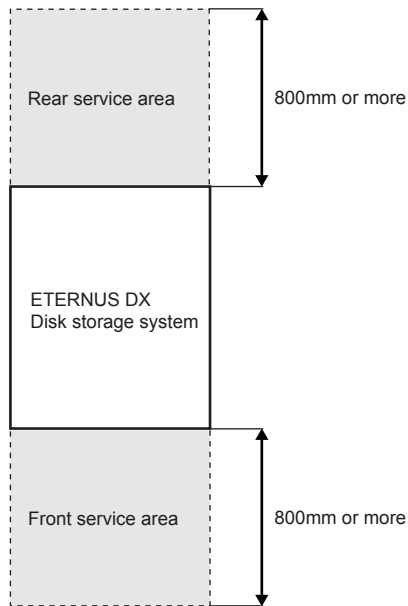

Figure 2.1 Installation area and service area

2.4 Installation Environment

Sufficient consideration of the installation environment should be taken to ensure proper use of the ETERNUS DX Disk storage system. Using the ETERNUS DX Disk storage system in an environment that does not satisfy the installation environment requirements may cause a failure to occur with the ETERNUS DX Disk storage system.

2.4.1 Air Conditioning

It is important to consider the flows of cooling air (intake air) and exhaust air for the installation location. The temperature in some ETERNUS DX Disk storage systems may rise when exhaust air is taken in from other ETERNUS DX Disk storage systems. In addition, check other factors that might affect the usage environment temperature, such as the room size, whether other ETERNUS DX Disk storage systems are installed, and how many people are present in the room.

When installing air conditioning, the ambient temperature should be considered.

- Ambient temperature

An ETERNUS DX Disk storage system is cooled by taking in air through the front intakes and pushing out the exhaust air through the rear of the ETERNUS DX Disk storage system. If the intake air temperature does not meet the ambient environment conditions, a temperature error occurs and the power of the ETERNUS DX Disk storage system is shut down.

- Front intake air temperature

Make sure that the front intake air temperature is between 5 and 40°C.

- Rear exhaust air temperature

For example, when the intake air temperature is 40°C, the exhaust air temperature is 45°C or higher.

Check the heat generation amount and the exhaust air amount that are listed in ["2.1 Installation Specifications" \(page 26\)](#) for the necessary cooling capacity of air conditioning.

2.4.2 Earthquake Resistance

Take the necessary measures (e.g. secure the rack to the floor or wall) to prevent a rack in which an ETERNUS DX Disk storage system is installed from falling down when earthquakes occur. Earthquake countermeasures vary depending on the installation location, the floor conditions, and the type of rack that is used. Contact your installation contractor for more details regarding earthquake countermeasure methods and how work should be conducted.

2.4.3 Load Bearing Capacity for Floors

Make sure that the following relationship between the load bearing capacity of the floor and the weight of the ETERNUS DX Disk storage system is maintained.

(Load bearing capacity of the floor) > (ETERNUS DX Disk storage system weight ÷ Installation area that includes service areas)

If the condition above is not satisfied, additional measures are required to ensure sufficient load bearing capacity. Contact your installation contractor for details about the necessary measures that must be taken.

2.5 Outlet/Socket Specifications

Power can be supplied to the ETERNUS DX Disk storage system from two power sources because each enclosure has two power supply units. During normal operation, each of the power sources supplies half of the necessary power. When one of the power supply lines fails, all of the necessary power is supplied from only one power source.

Using the same power supply condition for all of the power supply units is recommended so that different power supply conditions (such as whether power distribution units are used or not and input voltage) are not used for the ETERNUS DX Disk storage system.

This section explains the power connection specifications of the ETERNUS DX Disk storage systems.

2.5.1 Specifications for Optional Power Supply Products

This section explains the specifications of optional power cords and power related optional products.

When using power distribution units, the number of outlets that are required for controller enclosure and drive enclosure connection should be taken into consideration.

In addition, make sure that the plug type of the power distribution unit fits the power socket when using an existing power socket. If the plug type does not fit the power socket, replace the socket.

■ Power cords

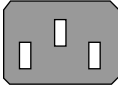

- Power cords supplied with the ETERNUS DX Disk storage system (for the EMEA&I region)

Table 2.3 Specifications for power cords supplied with the ETERNUS DX Disk storage system (for the EMEA&I region)

Usage	Plug type	Socket type	Cable length	Remarks
Used for connection between the ETERNUS DX Disk storage system and the socket (IEC60320-C13 ↔ IEC60320-C14G)	IEC60320-C14G 	IEC60320-C13 	2.5m	250V 10A

- Power cords supplied with the ETERNUS DX Disk storage system (for regions other than EMEA&I)



Table 2.4 Specifications for power cords supplied with the ETERNUS DX Disk storage system (for regions other than EMEA&I)

Usage	Plug type	Socket type	Cable length	Remarks
Used for connection between the ETERNUS DX Disk storage system and the socket (IEC60320-C13 ↔ NEMA L6-15P)	NEMA L6-15P 	NEMA L6-15R 	4.0m	250V 15A (Normal usage <12A)

■ Power distribution units (only for regions other than EMEA&I)

- Power distribution unit for DX60 S2 (AC200-240V, 1U, Max 2 enclosures connection)

Table 2.5 Specifications for power distribution unit for DX60 S2 (AC200-240V, 1U, Max 2 enclosures connection)

Output	Input			Remarks
Outlet type	Plug type	Socket type	Cable length	
IEC60320-C13 	NEMA L6-15P 	NEMA L6-15R 	4.0m	250V 15A (Normal usage <12A)

- Power distribution unit for DX60 S2 (AC200-240V, 2U, Max 6 enclosures connection)

Table 2.6 Specifications for power distribution unit for DX60 S2 (AC200-240V, 2U, Max 6 enclosures connection)

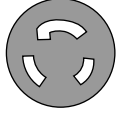
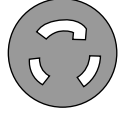
Output	Input			Remarks
Outlet type	Plug type	Socket type	Cable length	
IEC60320-C13 	NEMA L6-20P 	NEMA L6-20R 	4.0m	250V 20A (Normal usage <16A)

- Power distribution unit for DX60 S2 (AC200-240V, 2U, Max 8 enclosures connection)

Table 2.7 Specifications for power distribution unit for DX60 S2 (AC200-240V, 2U, Max 8 enclosures connection)

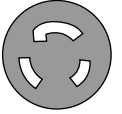
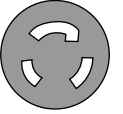
Output	Input			Remarks
Outlet type	Plug type	Socket type	Cable length	
IEC60320-C13 	NEMA L6-30P 	NEMA L6-30R 	4.0m	250V 30A (Normal usage <24A)

2.5.2 Required Number of Outlets/sockets

The number of power outlets/sockets required to install the ETERNUS DX Disk storage system depends on the number of drive enclosures and power distribution units. It is recommended that the power cord of a drive enclosure is connected to the power distribution unit that is installed in the same rack. Secure the necessary number of power outlets within the same rack to avoid connecting power cords to power outlets in different racks. It may be necessary to purchase additional power distribution units depending on the installation locations of enclosures.

- Without power distribution units

Two power sockets are required for each enclosure (controller enclosure and drive enclosure).

- With power distribution units

Two power sockets are required for each power distribution unit. There are three types of power distribution units. The size and number of outlets are different for each type.

Table 2.8 Required number of outlets and sockets to install power distribution units

Product name	Number of outlets	Number of sockets
Power distribution unit for DX60 S2 (AC200-240V, 1U, Max 2 enclosures connection)	4	2
Power distribution unit for DX60 S2 (AC200-240V, 2U, Max 6 enclosures connection)	12	2
Power distribution unit for DX60 S2 (AC200-240V, 2U, Max 8 enclosures connection)	16	2

- Power distribution unit (1U)

Up to two enclosures can be connected to a single power distribution unit (1U).

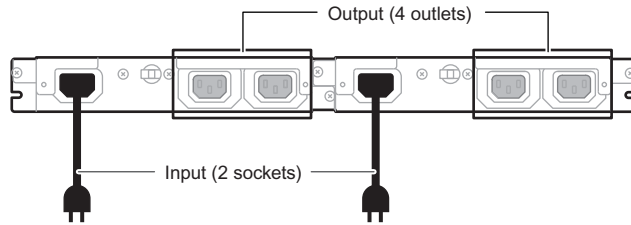

Figure 2.2 Power distribution unit (1U)

- Power distribution unit (2U)

- Power distribution unit for DX60 S2 (AC200-240V, 2U, Max 6 enclosures connection)
Up to six enclosures can be connected.
- Power distribution unit for DX60 S2 (AC200-240V, 2U, Max 8 enclosures connection)
Up to eight enclosures can be connected.

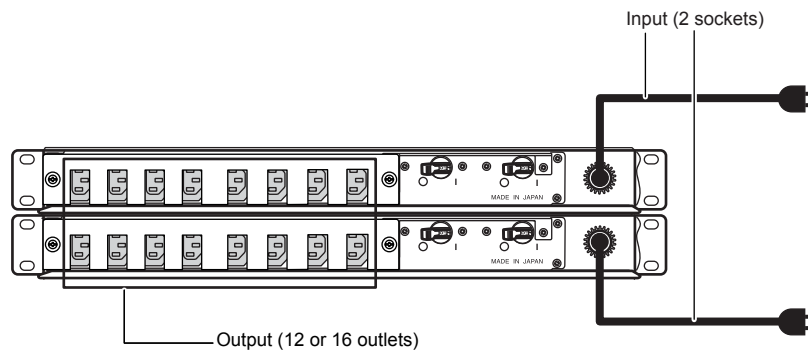

Figure 2.3 Power distribution unit (2U)

2.6 Circuit Protectors

Protection coordination must be secured between the distribution board circuit protectors and the ETERNUS DX Disk storage system or power distribution units to protect the ETERNUS DX Disk storage system by blocking the failed circuit immediately when a power supply input error occurs. Distribution board circuit protectors must satisfy the following required conditions and breaking characteristics.

2.6.1 Required Conditions

The distribution board circuit protectors must satisfy the required conditions that are listed in [Table 2.9](#).

Table 2.9 Required conditions for distribution board circuit protectors

Connected device	Power supply voltage	Current capacity	
		Regions other than EMEA&I	EMEA&I region
Power distribution unit for DX60 S2 (AC200-240V, 1U, Max 2 enclosures connection)	AC200 – 240V	15A	—
Power distribution unit for DX60 S2 (AC200-240V, 2U, Max 6 enclosures connection)	AC200 – 240V	20A	—
Power distribution unit for DX60 S2 (AC200-240V, 2U, Max 8 enclosures connection)	AC200 – 240V	30A	—
ETERNUS DX Disk storage system (without power distribution units)	AC100 – 120V AC200 – 240V	15A	16A

2.6.2 Breaking Characteristics

- For power distribution unit (2U) connection

The breaking characteristics (*1) of distribution board circuit protectors must be slower than the values shown in [Figure 2.4](#) or equivalent to D (IEC898).

*1: Relationship between the size of excess current and operation time

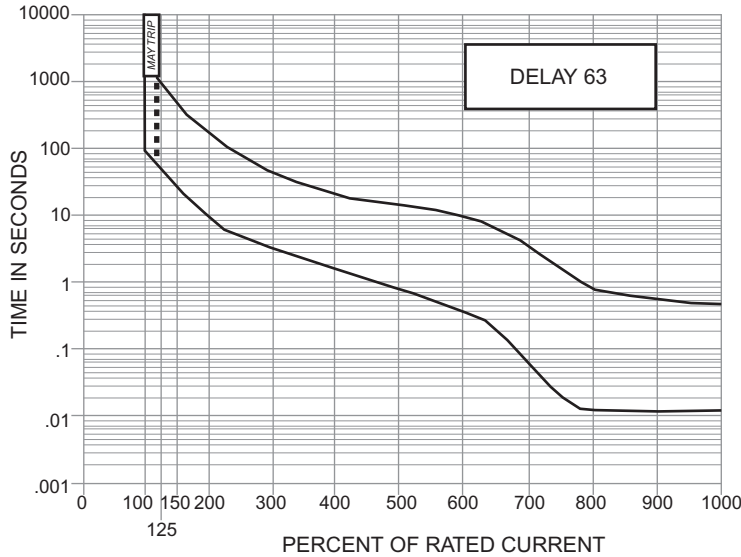

Figure 2.4 Power distribution unit (2U) breaking characteristics (graph)

Table 2.10 Power distribution unit (2U) breaking characteristics (Trip time (sec.))

Delay	100%	125%	150%	200%	400%	600%	800%	1000%
63	No Trip	50 to 700	30 to 400	10 to 150	1.5 to 20	0.4 to 10	0.013 to 0.85	0.013 to 0.5

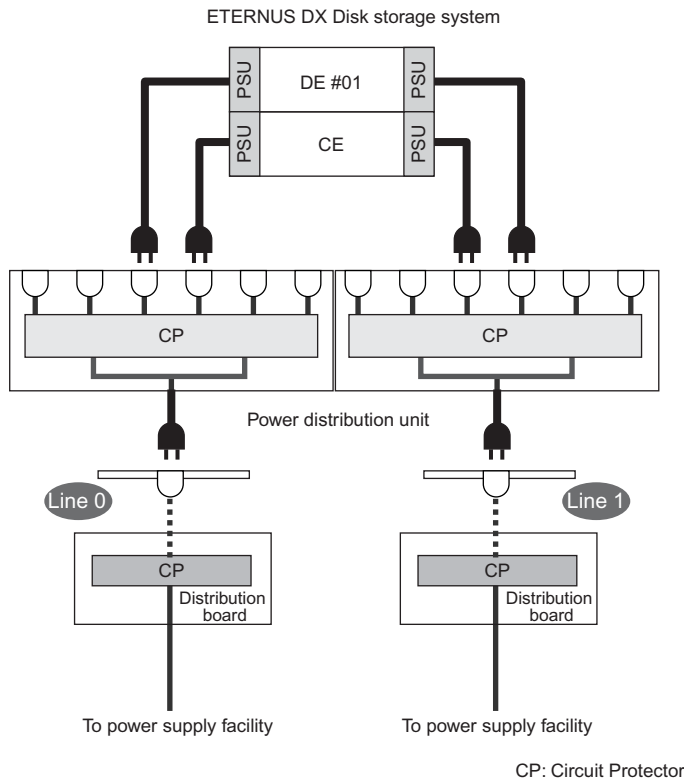

Figure 2.5 Example of a power supply connection using a power distribution unit (2U)

■ For power distribution unit (1U) connection

The breaking characteristics of distribution board circuit protectors must be slower than the values shown in [Figure 2.6](#) or equivalent to D (IEC898).

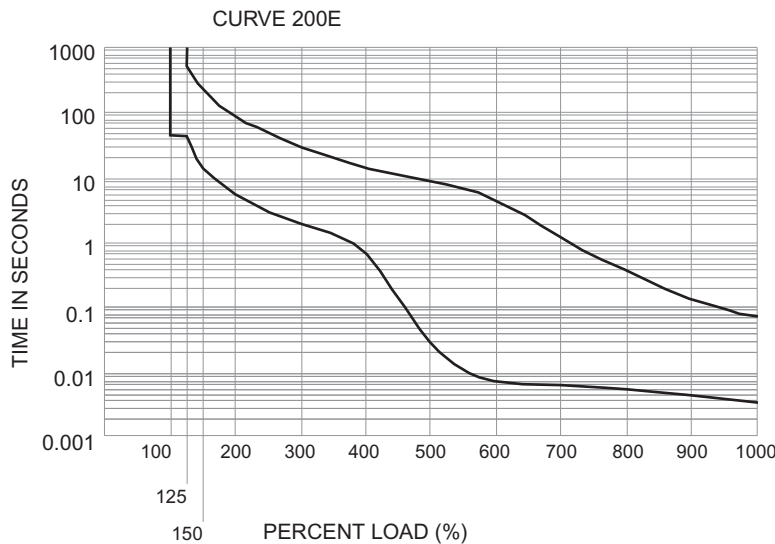

Figure 2.6 Power distribution unit (1U) breaking characteristics (graph)

Table 2.11 Power distribution unit (1U) breaking characteristics (Trip time (sec.))

Delay	100%	125%	150%	200%	400%	600%	800%	1000%
200E	No Trip	45 to 500	15 to 250	6 to 90	0.7 to 15	0.008 to 5	0.006 to 0.4	0.004 to 0.08

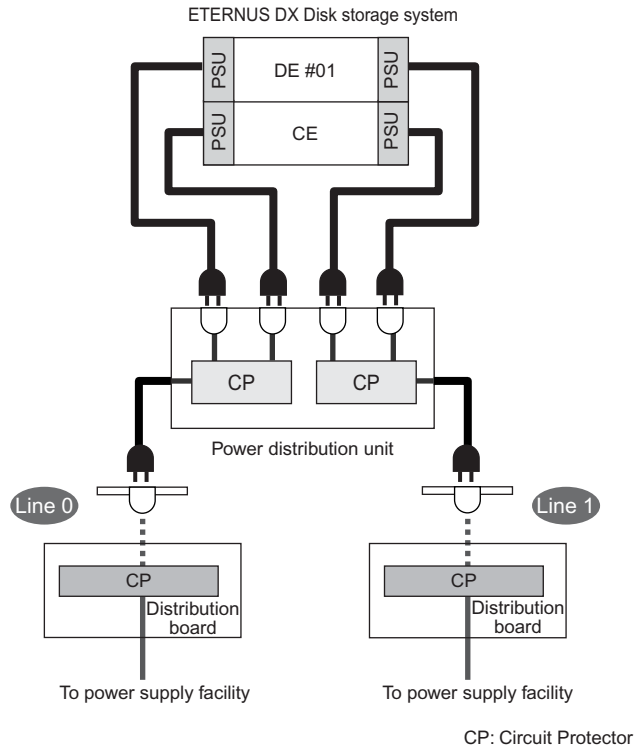

Figure 2.7 Example of a power supply connection using a power distribution unit (1U)

- For direct (no power distribution unit) connection

The breaking characteristics of distribution board circuit protectors must be slower than the values shown in [Figure 2.8](#) or equivalent to D (IEC898).

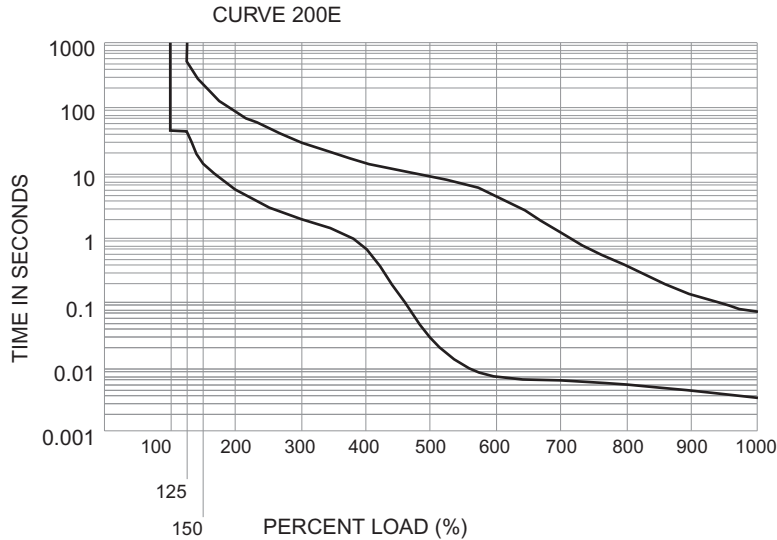

Figure 2.8 ETERNUS DX Disk storage system (PSU) breaking characteristics (graph)

Table 2.12 ETERNUS DX Disk storage system (PSU) breaking characteristics (Trip time (sec.))

Delay	100%	125%	150%	200%	400%	600%	800%	1000%
200E	No Trip	45 to 500	15 to 250	6 to 90	0.7 to 15	0.008 to 5	0.006 to 0.4	0.004 to 0.08

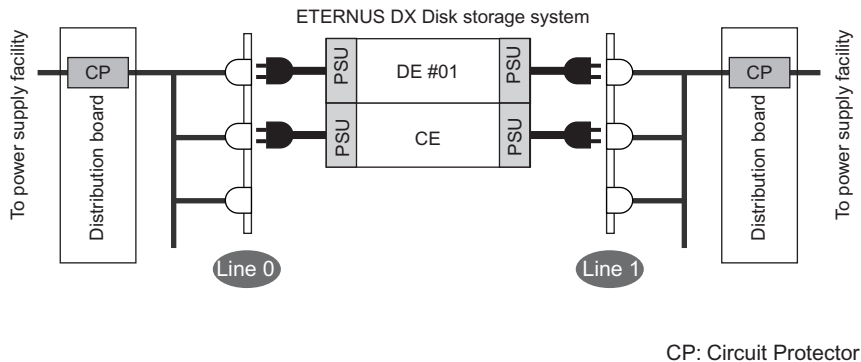

Figure 2.9 Example of a power supply connection without power distribution units

Do

- Only connect the ETERNUS DX Disk storage system to circuit protectors.

Chapter 3 Connections

This chapter explains connections for the ETERNUS DX Disk storage system.

3.1 Host Connections

FC, iSCSI, and SAS host interface models are available for the ETERNUS DX60 S2. The server and the ETERNUS DX Disk storage system can be connected directly or via a switch.

3.1.1 Host Interfaces

This section describes each host interface.

■ FC (Fibre Channel)

FC supports two connection topologies: Fibre Channel Arbitrated Loop (FC-AL) and Fabric. Direct connections and switch connections to servers are available. The maximum transfer speed is 4Gbit/s.



When FC switches are used, zoning should be set for the FC switches to ensure the security of data.

■ iSCSI

Direct connections and switch connections to servers are available. The maximum transfer speed is 1Gbit/s.

In order to maintain iSCSI performance, the iSCSI network should be physically separated from other types of networks (such as networks for Internet access and file transfers).

- CHAP
CHAP authentication can prevent unauthorized access. The following CHAP authentication methods are supported:
 - Unidirectional CHAP
 - Bidirectional CHAP
- Jumbo Frame
Enabling Jumbo Frame makes data transfer more efficient by increasing the amount of data that can be transferred for each Frame.

Table 3.1 Ethernet frame capacity (Jumbo Frame settings)

Jumbo Frame settings	Ethernet frame capacity
Enabled	Up to 9000 bytes
Disabled	Up to 1500 bytes

Caution 

- Confirm that the connected device supports Jumbo Frame before enabling Jumbo Frame.
- Server-side CPU load can be reduced by using Jumbo Frame. However, I/O performance may be reduced by 10% to 30%.
- When using a LAN switch that supports the Flow Control function, disable the Flow Control function.
- When connecting to a server with VMware vSphere 4.0/4.1, disable the Flow Control function of the LAN switch.

■ SAS

Simple, cost effective, and high performance network storage environment can be configured. Direct connections to servers are available. The maximum transfer speed is 3Gbit/s.

Caution 

Up to two paths are allowed when the ETERNUS Multipath Driver is used.

3.1.2 Host Connection Path

This section explains the connection configuration between a server Host Bus Adapter (HBA) and an ETERNUS DX Disk storage system host interface port.

■ Single path configuration

A single path configuration connects the ETERNUS DX Disk storage system to a server via a single path.

The server cannot access an ETERNUS DX Disk storage system when a component (such as a controller, HBA, switch, or cable) on the path has a problem. The system must be stopped during the replacement of failed components and controller firmware.

In a single path connection configuration, the path failover and load balancing functions are not supported.

A multipath connection configuration is recommended to maintain availability when a problem occurs.

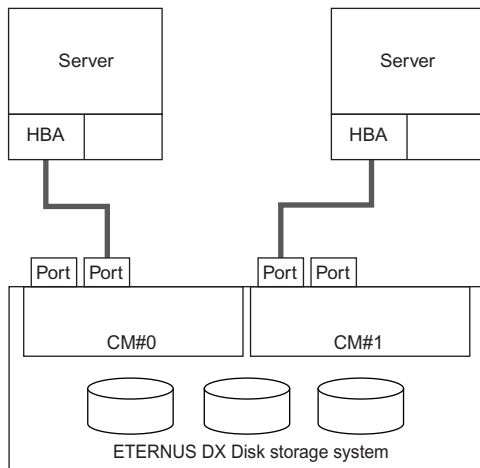

Figure 3.1 Single path connection (direct connection)

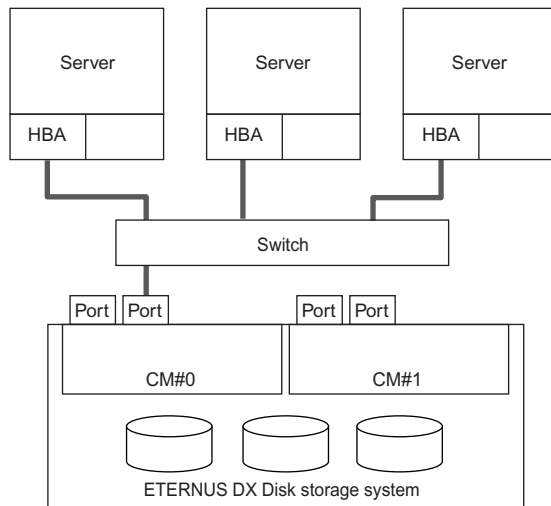

Figure 3.2 Single path connection (switch connection)

■ **Multipath configuration**

A multipath configuration connects the ETERNUS DX Disk storage system to a server via multiple paths (multipath). System reliability is improved due to the path redundancy. For multipath connections, driver software to control multipathing is required.

If a path fails, access can continue by using the path failover function that switches access from the failed path to another path. The performance of the system can be improved by using the load balancing function to spread the access load over multiple paths.



Note

To use the load balancing function, four or more paths must be used to connect the server and the ETERNUS DX Disk storage system.

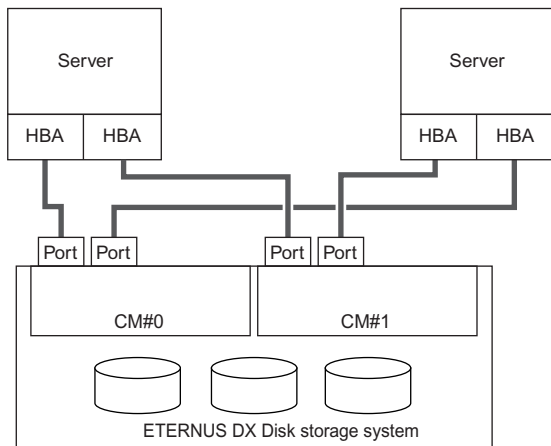

Figure 3.3 Multipath connection (direct connection)

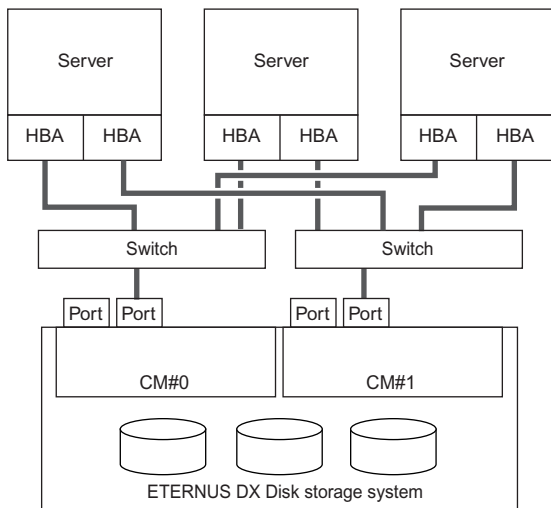

Figure 3.4 Multipath connection (switch connection)

Caution 

When configuring multipathing for reliability, make sure to configure a redundant connection for the controllers of the ETERNUS DX Disk storage system. Configure paths to connect to different controllers (CM#0 and CM#1). Combinations of host interface port numbers (Port#0 and Port#1) in controllers do not need to be taken into consideration.

■ Cluster configuration

When a server is duplicated in a cluster configuration and the ETERNUS DX Disk storage system is shared by multiple servers, software to control the cluster configuration is required.

3.2 LAN Connection

The ETERNUS DX Disk storage system requires a LAN connection for operation management. In addition, information such as ETERNUS DX Disk storage system failures is notified to the remote support center.

Note Make sure to connect each controller to the LAN for operation management.

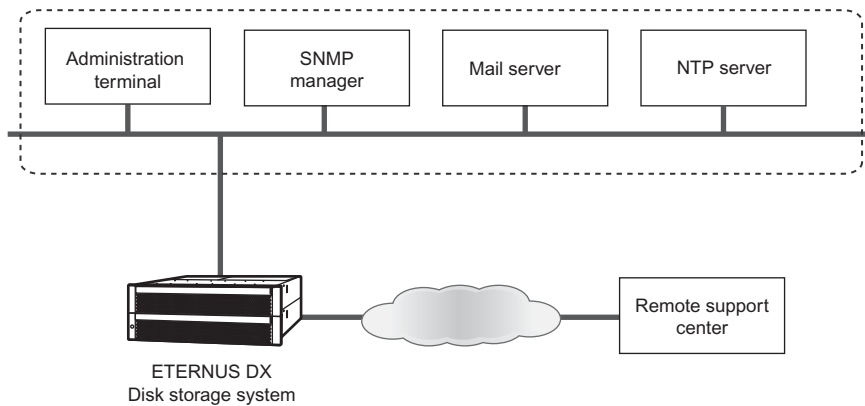

Figure 3.5 Example of a LAN connection

When using ETERNUS Web GUI to manage operations, prepare a Web browser in the administration terminal. The following table shows the supported Web browsers.

Table 3.2 ETERNUS Web GUI operating environment

Software	Guaranteed operating environment
Web browser	Microsoft Internet Explorer 6.0, 7.0, 8.0 Mozilla Firefox 3.0.x, 3.5.x, 3.6.x

When using ETERNUS Web GUI to connect the ETERNUS DX Disk storage system, the default port number is 80 for http or 443 for https.

LAN for operation management

In an ETERNUS DX Disk storage system, the system administrator logs on to the ETERNUS DX Disk storage system via a LAN to set the RAID configuration, manage operations, and perform maintenance. The computer for operation management that is used for accessing the ETERNUS DX Disk storage system via ETERNUS Web GUI or ETERNUS CLI is called an administration terminal.

In addition, the functions that are provided by the management/monitoring server on the LAN can be used. These functions include SNMP (device monitoring), SMTP (e-mail sending), and NTP (time correction).

■ LAN for remote support

Various failures that occur in the ETERNUS DX Disk storage system are notified to the remote support center. Remote support connection can be separated from the LAN for operation management.

3.3 Power Supply Connection

Connect the power cords (AC cables) of the ETERNUS DX Disk storage system to the power sockets, the UPS sockets, or the power control unit sockets. Refer to "[2.5 Outlet/Socket Specifications](#)" (page 31) for details about the types and the number of power outlets/sockets.

Note Two power supply units (PSU#0 and PSU#1) are installed in each enclosure. Make sure that power cords are connected to both of the power supply units.

3.3.1 Input Power Supply Lines

Multiple power supply facilities in the building or UPS units are recommended for power supply redundancy. When the ETERNUS DX Disk storage system power supply is redundantly configured, business can continue even if one of the power lines fails. To connect the ETERNUS DX Disk storage system to power supply facilities, use the following configurations to improve the availability of the power supply facilities if a power supply facility failure occurs.

- Connect the power cords of PSU#0 and PSU#1 to different lines.
- When a power distribution unit is used, separately connect it to line 0 (PSU#0) and line 1 (PSU#1).

Alternatively, optimal system design (including the server) may instead lead to the ETERNUS DX Disk storage system being configured with only a single power supply facility or UPS unit. Which configuration is selected will depend on system availability requirement considerations.

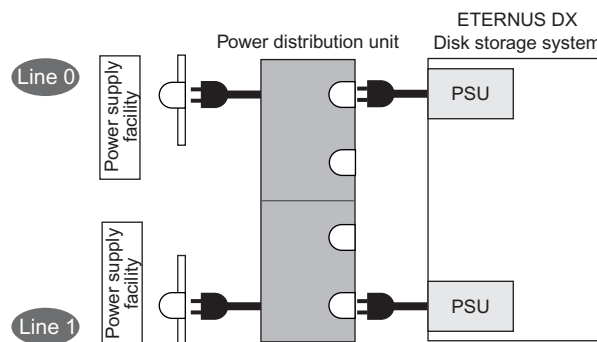

Figure 3.6 Dual-line power supply when connecting to power sockets

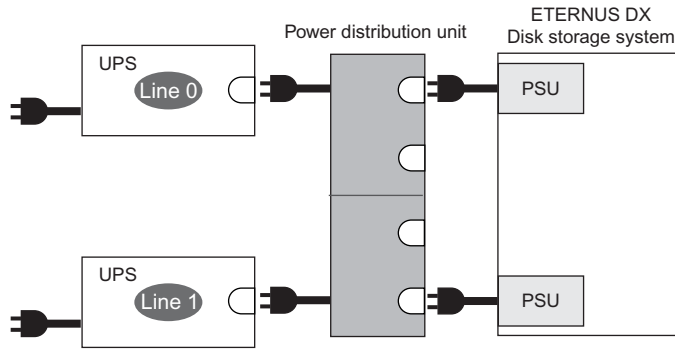

Figure 3.7 Dual-line power supply when connecting to UPS units

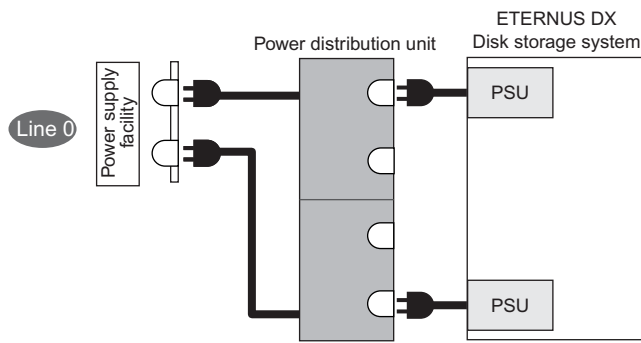

Figure 3.8 Single-line power supply when connecting to power sockets

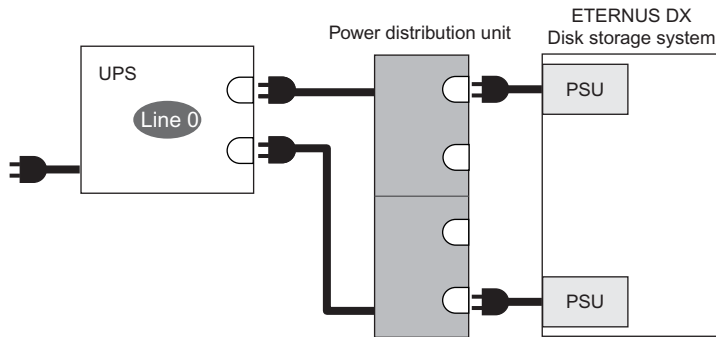

Figure 3.9 Single-line power supply when connecting to a UPS unit

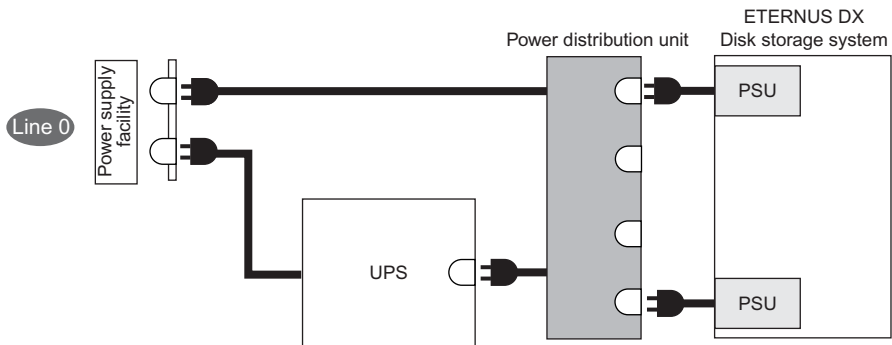

Figure 3.10 Single-line power supply when connecting to a power socket and a UPS unit

3.3.2 UPS Connection

It is recommended that an Uninterruptible Power Supply System (UPS) be used as the power supply source for the ETERNUS DX Disk storage system to cope with power outages and momentary voltage drops in the normal power supply.

Note that when connecting an ETERNUS DX Disk storage system to a UPS with one power supply line, the total value of the power requirements for all the enclosures must not exceed the UPS output capacity.

When one of the power supply lines fails for redundantly configured UPS units with two power supply lines, all of the power for the ETERNUS DX Disk storage system must be supplied from the other line. Select a UPS that can supply sufficient power so that the total value of the power requirements does not exceed the UPS output capacity in case only one power supply line is available.

For details about the necessary UPS output capacity, refer to the specifications of the UPS that is used.

A UPS must satisfy the following conditions:

- Rating capacity

Secure a sufficient rating capacity for the total value of the maximum power requirements for the enclosures that are to be installed.

For the maximum power requirements of each enclosure, refer to ["2.1 Installation Specifications" \(page 26\)](#).

- Supply time

Consider the power supply time of the battery to make sure that the ETERNUS DX Disk storage system power is not turned off before the server shuts down.

- Socket type

If the power plug type and the socket type of the UPS do not match, it is necessary to equip the UPS (AC output) with an appropriate type of socket. Request a qualified electrician to perform the necessary work to make terminal block connections available.

- Power supply configuration

If a UPS is used, make sure that it supplies power to all the enclosures.

Configurations where the controller enclosure is powered by the UPS while the drive enclosure is powered directly from AC are not supported.

3.4 Power Synchronized Connections

This section describes connections to automatically control powering the ETERNUS DX Disk storage system on and off with a server.

■ Power synchronized unit

A power synchronized unit enables the ETERNUS DX Disk storage system to be powered on and off with a server. The power synchronized unit detects changes in the AC power output of a UPS unit that is connected to a server (server UPS unit) and automatically turns on and off the ETERNUS DX Disk storage system. In addition to server UPS units, units that control the AC socket power output can also be connected. When three or more servers are connected, power can be synchronized by adding an AC sensor unit.

The power synchronized unit detects the AC power output of the target devices for power synchronization and commands the ETERNUS DX Disk storage system to synchronize the power with the target devices.

When the power synchronized unit detects the AC power output of any server UPS unit, the power synchronized unit commands the ETERNUS DX Disk storage system to turn on. When the power synchronized unit does not detect AC power output in any of the server UPS units, the power synchronized unit commands the ETERNUS DX Disk storage system to turn off. The server UPS unit must have a function in the management software that controls the AC power output according to when the server powers on and off. The server UPS unit must have one unused outlet to connect to the power synchronized unit.

- When connecting one or two servers

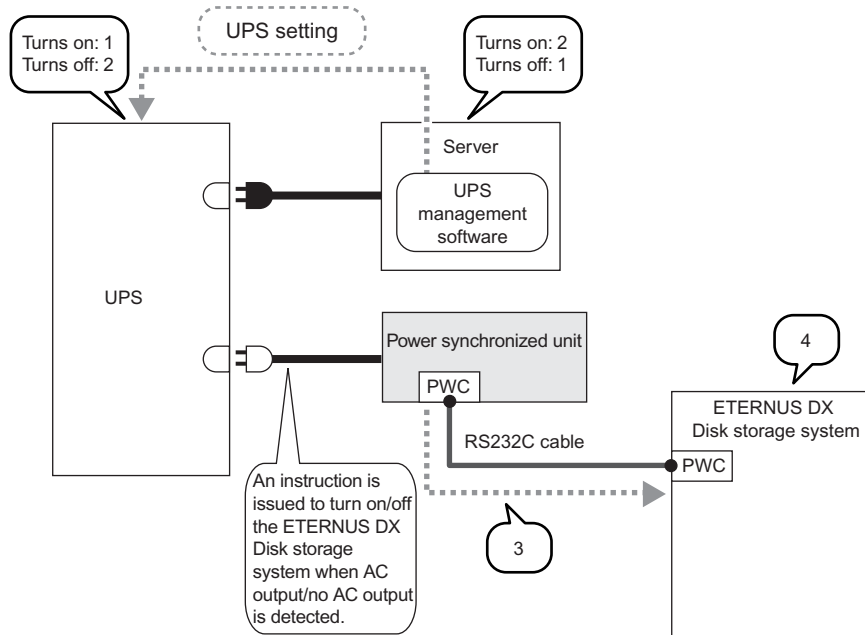

Figure 3.11 Power control using a power synchronized unit (when connecting one or two servers)

- Powering on sequence

- 1 Power on of all the server UPS units
 - 2 Server startup
The server OS startup is suspended until the ETERNUS DX Disk storage system startup is complete (*1).
 - 3 Issuance of command to turn on the ETERNUS DX Disk storage system from the power synchronized unit
 - 4 ETERNUS DX Disk storage system startup
- *1: The server must be set to suspend server OS startup until the ETERNUS DX Disk storage system startup is complete.

- Powering off sequence

- 1 Shutdown of all the servers
- 2 Shutdown of all the server UPS units
- 3 Issuance of command to turn off the ETERNUS DX Disk storage system from the power synchronized unit
- 4 ETERNUS DX Disk storage system shutdown

- When connecting three or more servers

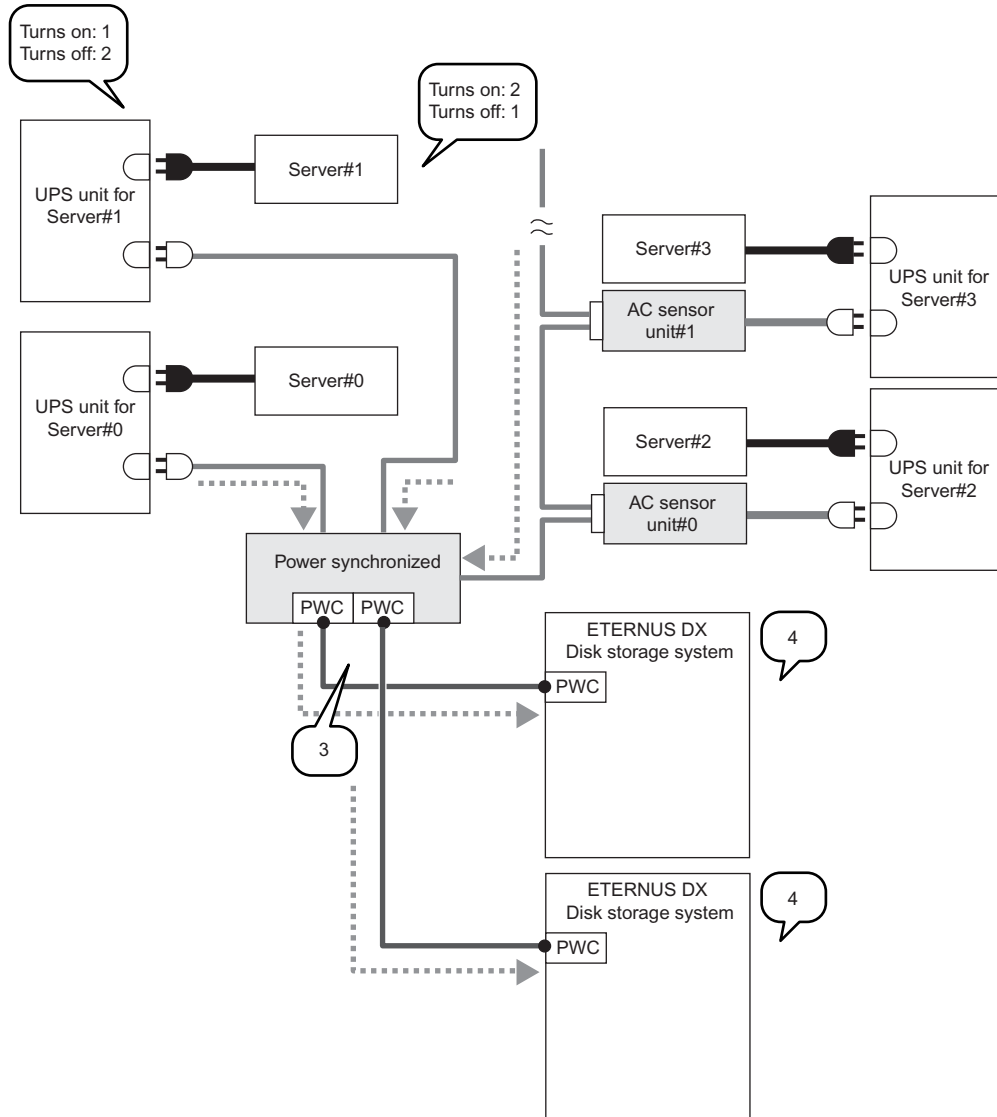

Figure 3.12 Power control using a power synchronized unit (when connecting three or more servers)

● Powering on sequence

- 1 Power on of all the server UPS units
- 2 Server startup
 The server OS startup is suspended until the ETERNUS DX Disk storage system startup is complete (*1).
- 3 Issuance of command to turn on the ETERNUS DX Disk storage system from the power synchronized unit
- 4 ETERNUS DX Disk storage system startup

*1: The server must be set to suspend server OS startup until the ETERNUS DX Disk storage system startup is complete.

- Powering off sequence

- 1** Shutdown of all the servers
- 2** Shutdown of all the server UPS units
- 3** Issuance of command to turn off the ETERNUS DX Disk storage system from the power synchronized unit
- 4** ETERNUS DX Disk storage system shutdown

Refer to the manual that is provided with a power synchronized unit for details about connection configurations with power synchronized units and required settings.

Chapter 4 Rack and Optional Product Installation

This chapter explains the requirements for installation of racks and the optional products for an ETERNUS DX Disk storage system.

4.1 Rack Installation Requirements

This section explains the requirements for installing the ETERNUS DX Disk storage system in a 19-inch rack.

Enclosures are installed in the following order (from bottom to top).

The center of gravity must be taken into consideration to prevent a rack from toppling over.

Enclosures should generally be installed from bottom to top to lower the center of gravity and to ensure the safe use of racks.

Table 4.1 Enclosure installation order

Order	Enclosure	Size (height)
1	Power distribution unit (PDU)	1U/2U
2	Controller enclosure (CE)	2U
3	Drive enclosure (DE)	2U



Install the controller enclosure and drive enclosure in the same rack.



Note

- When determining the rack-mounting layout, consider the placement of each enclosure and the power distribution unit in the rack and the length of each cable. For example, if the ETERNUS DX Disk storage system is installed at the top of a 1800mm rack, the surplus length of the power cord at the bottom of a rack should be about 2m.
- If the storage system is installed at the bottom of a rack, a space for the surplus of cables may not be available in some racks, preventing the storage system from being pulled out when maintenance work is required.
In this case, secure a space of 1U or more at the bottom when installing the storage system.

4.2 Installable Racks

This section explains the racks in which the ETERNUS DX Disk storage system can be installed.

4.2.1 Fujitsu Racks

The ETERNUS DX Disk storage system can be installed in a Fujitsu 19-inch rack. For information about whether the ETERNUS DX Disk storage system can be installed in an EOLed rack or not, contact your sales representative.

4.2.2 Non-Fujitsu Racks

ETERNUS DX Disk storage systems are developed and their operation is guaranteed on the assumption that they are installed in Fujitsu 19-inch racks. Since the ETERNUS DX Disk storage system cannot be tested (for cooling and strength) in non-Fujitsu 19-inch racks, the operations of ETERNUS DX Disk storage systems cannot be guaranteed. Any problem that may occur by installing the ETERNUS DX Disk storage system in non-Fujitsu racks is not covered by the warranty.

If the ETERNUS DX Disk storage system needs to be installed in a non-Fujitsu rack, the following conditions must be satisfied.

■ Rack specifications

Use the rack mount kit supplied with the product to install the ETERNUS DX Disk storage system in the rack. The rack specifications must satisfy the conditions listed below. For rack specifications, refer to the manual that is supplied with the rack that is used.

- Pitch for mounting holes
EIA Standard Universal pitch
- Size for mounting holes
The size must be 9mm or more.
- Load bearing capacity
The load bearing capacity must be equal to or larger than the total weight of the ETERNUS DX Disk storage system.
- Unit installation area
The dimensions of the area shown in [Figure 4.1](#) must match the conditions described in [Table 4.2](#).

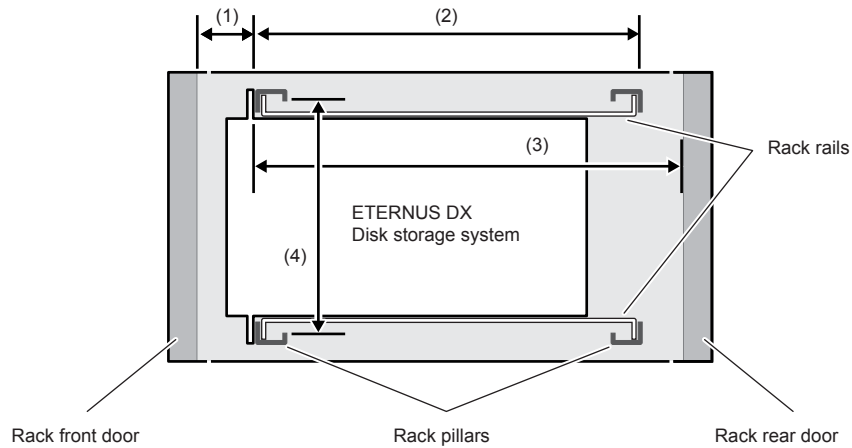

Figure 4.1 Unit installation area

Table 4.2 Specifications for the unit installation area

Specification		Condition
(1)	Rack front space (From the fixed part of the ETERNUS DX Disk storage system on the front side to the inner side of the front rack door)	40mm or more
(2)	Mount bracket length (Size between each end of the front and rear rack pillars)	630mm to 800mm
(3)	Rack space (From the fixed part of the ETERNUS DX Disk storage system on the front side to the inner side of the rear rack door)	830mm or more
(4)	Rack mount kit installation area	482mm or more (recommended)

■ Placement conditions

When determining service areas, refer to the installation document of the rack to be used. Install air conditioning in order to ensure that the interior temperature of the rack satisfies the temperature conditions listed in ["2.1 Installation Specifications" \(page 26\)](#) and ["2.4.1 Air Conditioning" \(page 30\)](#).

4.3 Standard Installation Rules Before Shipment (Only for Regions Other than EMEA&I)

This section explains the rules for combining the following optional products and standard installation rules that apply before shipment from the factory.

- Drive enclosures
- Disks

4.3.1 Drive Enclosures

This section explains the installation rules for a drive enclosure.

■ 2.5" type controller enclosure

Drive enclosures cannot be connected.

■ 3.5" type controller enclosure

Only one drive enclosure can be connected.

4.3.2 Disks

This section explains the installation rules for disks.

■ 2.5" disks

The following table shows the priority order of 2.5" disk installation.

Table 4.3 Priority order of 2.5" disk installation

Priority order	Type	Disk capacity/quantity	RAID level
1	2.5" SAS disk	300GB/10krpm × 2	RAID1
2		300GB/10krpm × 6	RAID1+0
3		300GB/10krpm × 6	RAID5
4		300GB/10krpm × 6	RAID6
5		300GB/10krpm × 1	Hot spare
6		450GB/10krpm × 2	RAID1
7		450GB/10krpm × 6	RAID1+0
8		450GB/10krpm × 6	RAID5
9		450GB/10krpm × 6	RAID6
10		450GB/10krpm × 1	Hot spare
11		600GB/10krpm × 2	RAID1
12		600GB/10krpm × 6	RAID1+0
13		600GB/10krpm × 6	RAID5
14		600GB/10krpm × 6	RAID6
15		600GB/10krpm × 1	Hot spare
16		900GB/10krpm × 2	RAID1
17		900GB/10krpm × 6	RAID1+0
18		900GB/10krpm × 6	RAID5
19		900GB/10krpm × 6	RAID6
20		900GB/10krpm × 1	Hot spare
21	2.5" Nearline SAS disk	1TB/7.2krpm × 2	RAID1
22		1TB/7.2krpm × 6	RAID1+0
23		1TB/7.2krpm × 6	RAID5
24		1TB/7.2krpm × 6	RAID6
25		1TB/7.2krpm × 1	Hot spare

Up to twenty-four 2.5" disks can be installed in a 2.5" type controller enclosure. Install disks in the slots of a controller enclosure from Slot#0 to Slot#23 in ascending order according to the installation order in [Table 4.3](#).

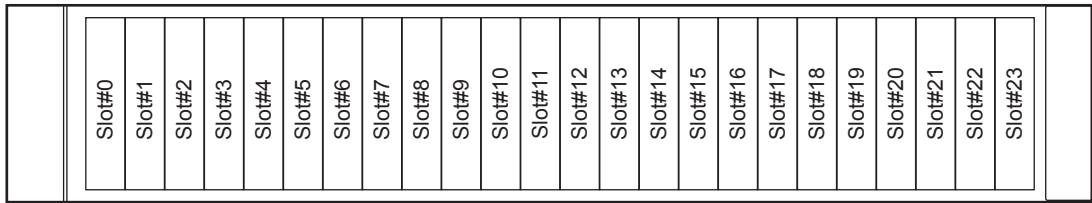

Figure 4.2 Installation diagram for 2.5" disks

■ 3.5" disks

The following table shows the priority order of 3.5" disk installation.

Table 4.4 Priority order of 3.5" disk installation

Priority order	Type	Disk capacity/quantity	RAID level
1	3.5" SAS disk	300GB/15krpm × 2	RAID1
2		300GB/15krpm × 6	RAID1+0
3		300GB/15krpm × 6	RAID5
4		300GB/15krpm × 6	RAID6
5		300GB/15krpm × 1	Hot spare
6		450GB/15krpm × 2	RAID1
7		450GB/15krpm × 6	RAID1+0
8		450GB/15krpm × 6	RAID5
9		450GB/15krpm × 6	RAID6
10		450GB/15krpm × 1	Hot spare
11		600GB/15krpm × 2	RAID1
12		600GB/15krpm × 6	RAID1+0
13		600GB/15krpm × 6	RAID5
14		600GB/15krpm × 6	RAID6
15		600GB/15krpm × 1	Hot spare

Priority order	Type	Disk capacity/quantity	RAID level
16	3.5" Nearline SAS disk	1TB/7.2krpm × 2	RAID1
17		1TB/7.2krpm × 6	RAID1+0
18		1TB/7.2krpm × 6	RAID5
19		1TB/7.2krpm × 6	RAID6
20		1TB/7.2krpm × 1	Hot spare
21		2TB/7.2krpm × 2	RAID1
22		2TB/7.2krpm × 6	RAID1+0
23		2TB/7.2krpm × 6	RAID5
24		2TB/7.2krpm × 6	RAID6
25		2TB/7.2krpm × 1	Hot spare
26		3TB/7.2krpm × 2	RAID1
27		3TB/7.2krpm × 6	RAID1+0
28		3TB/7.2krpm × 6	RAID5
29		3TB/7.2krpm × 6	RAID6
30	3TB/7.2krpm × 1	Hot spare	

Up to twelve 3.5" disks can be installed in a controller enclosure (3.5" type) or a drive enclosure. Disks with different types can be installed in a single enclosure. Install disks in the slots of a controller enclosure from Slot#0 to Slot#11 in ascending order according to the installation order in [Table 4.4](#). Then, install disks in the slots of a drive enclosure from Slot#0 to Slot#11 in ascending order.

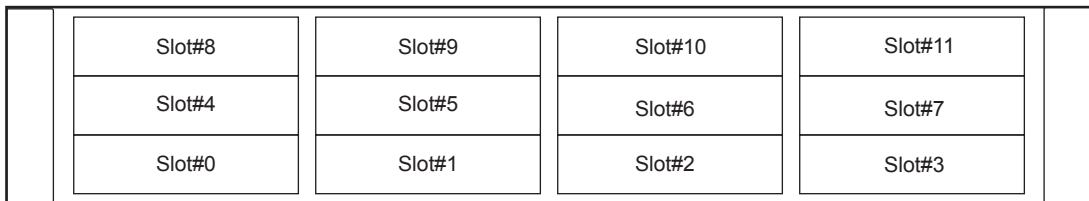

Figure 4.3 Installation diagram for 3.5" disks

4.3.3 Disk Installation Examples

This section provides examples of disk installation at shipment.

■ 2.5" type controller enclosure

Up to twenty-four 2.5" disks can be installed in a controller enclosure. When optional disks are purchased at the same time as the ETERNUS DX Disk storage system, the ETERNUS DX Disk storage system is shipped from the factory with the disks installed in the enclosure. The following diagram shows an example of the installation order for optional disks.

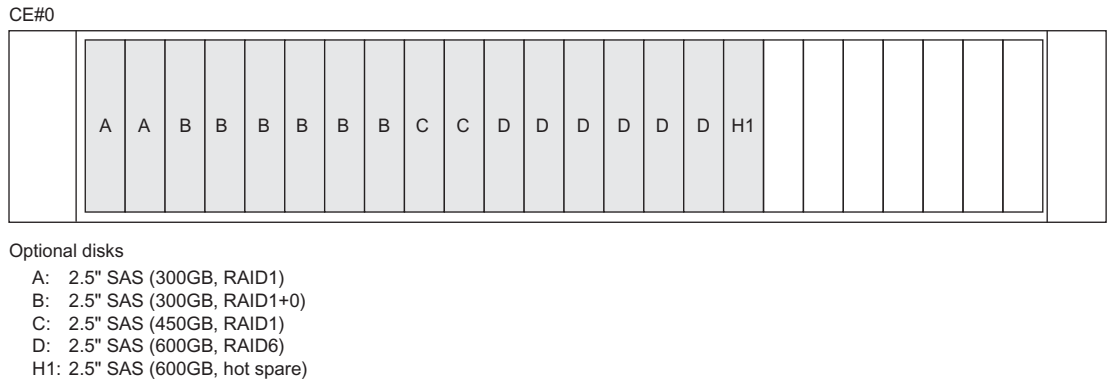

Figure 4.4 Disk installation example at shipment (2.5" type controller enclosure)

■ 3.5" type controller enclosure

When a drive enclosure is added, up to twenty-four 3.5" disks can be installed. When optional disks are purchased at the same time as the ETERNUS DX Disk storage system, the ETERNUS DX Disk storage system is shipped from the factory with the disks installed in the enclosures. The following diagram shows an example of the installation order for optional disks.

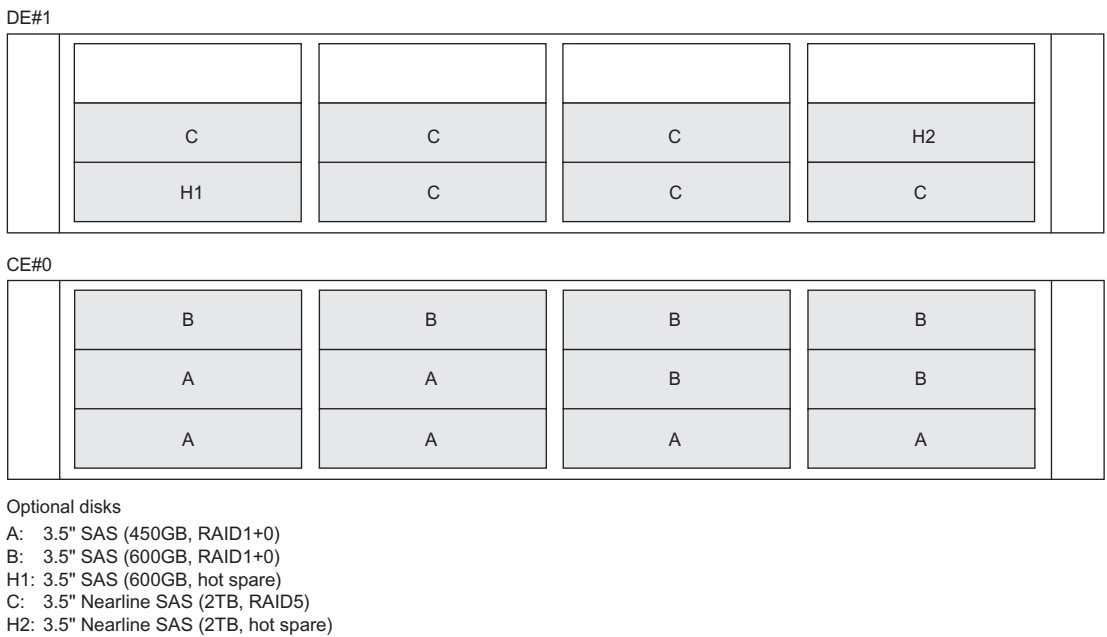

Figure 4.5 Disk installation example at shipment (3.5" type controller enclosure)

ETERNUS DX60 S2 Disk storage system
User's Guide -Site Planning-

P3AM-5492-04ENZ0

Date of issuance: May 2012
Issuance responsibility: FUJITSU LIMITED

- The content of this manual is subject to change without notice.
- This manual was prepared with the utmost attention to detail.
However, Fujitsu shall assume no responsibility for any operational problems as the result of errors, omissions, or the use of information in this manual.
- Fujitsu assumes no liability for damages to third party copyrights or other rights arising from the use of any information in this manual.
- The content of this manual may not be reproduced or distributed in part or in its entirety without prior permission from Fujitsu.

FUJITSU