

Emerson[®]

***HOME AUDIO SYSTEM
with 3-CD Changer,
Digital AM/FM Receiver
and Remote Control***

OWNER'S MANUAL



MS3110

Visit our web site at www.emersonradio.com



CAUTION

TO PREVENT FIRE OR SHOCK HAZARD, DO NOT USE THIS PLUG WITH AN EXTENSION CORD, RECEPTACLE OR OTHER OUTLET UNLESS THE BLADES CAN BE FULLY INSERTED TO PREVENT BLADE EXPOSURE. TO PREVENT FIRE OR SHOCK HAZARD, DO NOT EXPOSE THIS APPLIANCE TO RAIN OR MOISTURE.

 <p>The lightning flash with arrow-head symbol, within an equilateral triangle is intended to alert the user to the presence of uninsulated 'dangerous voltage' within the product's enclosure that may be of sufficient magnitude to constitute a risk of electric shock to persons.</p>	<p style="text-align: center;">CAUTION RISK OF ELECTRIC SHOCK DO NOT OPEN</p> <p>WARNING: TO REDUCE THE RISK OF ELECTRIC SHOCK DO NOT REMOVE COVER (OR BACK), NO USER SERVICEABLE PARTS INSIDE REFER SERVICING TO QUALIFIED SERVICE PERSONNEL.</p>	 <p>The exclamation point within an equilateral triangle is intended to alert the user to the presence of important operating and maintenance (servicing) instructions in the literature accompanying the appliance.</p>
--	--	---

The Caution Marking maybe located at the bottom enclosure of the apparatus.

IMPORTANT SAFETY INSTRUCTIONS

- 1.) Read these instructions. Keep these instructions. Follow all instructions. Heed all warnings.
- 2.) Do not use this apparatus near water.
- 3.) Clean only with dry cloth.
- 4.) Do not block any ventilation openings. Install in accordance with the manufacturer's instructions.
- 5.) Do not install near any heat sources such as radiators, heat registers, stoves, or other apparatus (including amplifiers) that produce heat.
- 6.) Do not defeat the safety purpose of the polarized or grounding-type plug. A polarized plug has two blades with one wider than the other. A grounding type plug has two blades and a third grounding prong. The wide blade or the third prong is provided for your safety. If the provided plug does not fit into your outlet, consult an electrician for replacement of the obsolete outlet.
- 7.) Protect the power cord from being walked on or pinched particularly at plugs, convenience receptacles, and the point where they exit from the apparatus.
- 8.) Only use attachments / accessories specified by the manufacturer.
- 9.) Unplug this apparatus during lightning storms or when unused for long periods of time.
- 10.) Refer all servicing to qualified service personnel. Servicing is required when the apparatus has been damaged in any way, such as power-supply cord or plug is damaged, liquid has been spilled or objects have fallen into the apparatus, the apparatus has been exposed to rain or moisture, does not operate normally, or has been dropped.
- 11.) This appliance shall not be exposed to dripping or splashing water and no object filled with liquids such as vases shall be placed on the apparatus.
- 12.) Use only with the cart, stand, tripod, bracket, or table specified by the manufacturer, or sold with the apparatus. When a cart is used, use caution when moving the cart/apparatus combination to avoid injury from tip-over.
- 13.) Do not overload wall outlet. Use only power source as indicated.
- 14.) Use replacement parts as specified by the manufacturer.
- 15.) The product may be mounted to a wall only if recommended by the manufacturer.
- 16.) Upon completion of any service or repairs to this product, ask the service technician to perform safety checks.





BEFORE WE BEGIN

Thank you for purchasing this Emerson audio product. The Emerson brand is your assurance of quality, performance and value.

Our engineers have included many useful and convenient features in this product. Please be sure to read this Owner's Manual completely to make sure you are getting the maximum benefit from each feature.

This product was manufactured using the highest quality components and standards of workmanship. It was tested by Emerson inspectors and found to be in perfect working order before it left our factory. However, there is always the chance that some problem may occur because of rough handling during shipment to the retail store or to the final consumer.

If, after reading this manual, you experience any problems with the operation of this product, please refer to the instructions for obtaining service at the end of this manual. Emerson and Emerson retailers are committed to your satisfaction.

Once again, thanks for purchasing this Emerson audio product.



IMPORTANT NOTES

- Avoid installing this unit in places exposed to direct sunlight or close to heat radiating appliances such as electric heaters, on top of other stereo equipment that radiates too much heat, places lacking ventilation or dusty areas, places subject to constant vibration and/ or humid or moist areas.
- Do not attempt to clean this unit with chemical solvents as this might damage the finish. Use a clean dry cloth.
- Operate controls and switches as described in the manual.
- Before turning 'On' the power, make certain that AC power cord is properly installed.
- Store your CDs in a cool area to avoid damage from heat.
- When moving the set, be sure to first disconnect the AC power cord.

CLASS 1 LASER PRODUCT

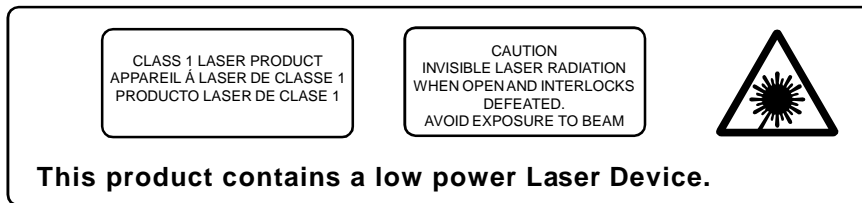

FCC Information

This equipment has been tested and found to comply with the limits for a Class B digital device, pursuant to Part 15 of the FCC Rules. These limits are designed to provide reasonable protection against harmful interference in a residential installation. This equipment generates, uses, and can radiate radio frequency energy and, if not installed and used in accordance with the instructions, may cause harmful interference to radio communications. However, there is no guarantee that interference will not occur in a particular installation. If this equipment does cause harmful interference to radio or television reception, which can be determined by turning the equipment off and on, the user is encouraged to try to correct the interference by one or more of the following measures:

- Reorient or relocate the receiving antenna.
- Increase the separation between the equipment and receiver.
- Connect the equipment into an outlet on a circuit different from that to which the receiver is connected.
- Consult the dealer or an experienced radio/TV technician for help.

This device complies with Part 15 of the FCC Rules. Operation is subject to the following two conditions:

- (1) This device may not cause harmful interference, and
- (2) This device must accept any interference received, including interference that may cause undesired operation.

Changes or modifications not expressly approved by the party responsible for compliance could void the user's authority to operate the equipment.



PREPARATION FOR USE

Unpacking and Set Up

- This carton contains the main unit, two speakers with removable front panels, the pedestal stand, and the remote control handset. Carefully remove all the components from the carton and remove all packing materials from the components. Make sure nothing is accidentally discarded with the packing materials.
- Save the carton and packing materials, if possible, in the unlikely event that this unit ever needs to be returned for service. Using the original carton and packing material is the only way to properly protect the unit from shipping damage.
- Remove any descriptive stickers or labels from the front panel of the main unit. Do not remove any labels or stickers that may be affixed to the back panel of the main unit or the speakers.
- Note the serial number on the back of the main unit and write this number in the space provided on the Warranty page of this manual.
- Unwind the AC power cord on the back of the main unit and extend it to its full length.
- Unwind the FM lead wire antenna on the back of the main unit and extend it to its full length.
- Unwind the speaker cables on the backs of the speakers and extend them to their full length.



Attaching The Pedestal Stand

Note: This system can be used and operated with or without the pedestal stand. If you plan to use this system on a bookshelf, for example, you may find that it is more convenient to use without the pedestal attached.

However the pedestal does provide extra stability so we do recommend attaching the pedestal if space is not a problem.

- 1.) Place the main unit face down on a flat surface as shown.

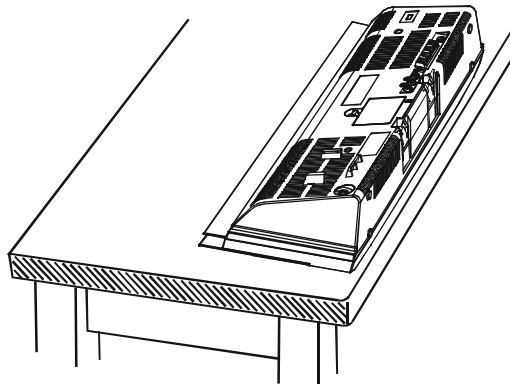

- 2.) Position the pedestal base so that the 4 guide rails on the base slide into the 4 slots on the bottom of the main unit.

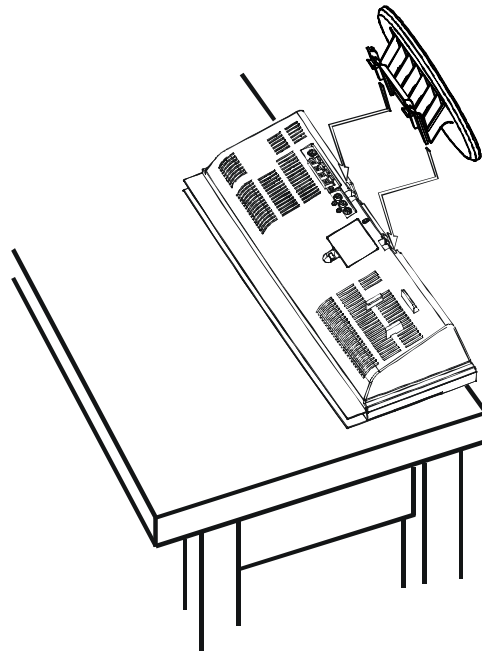



- 3.) Return the main unit and the pedestal base to the upright position and slide the main unit all the way backward in the direction of the 'arrow' onto the pedestal until the locking tabs 'click' and the main unit is locked in place.

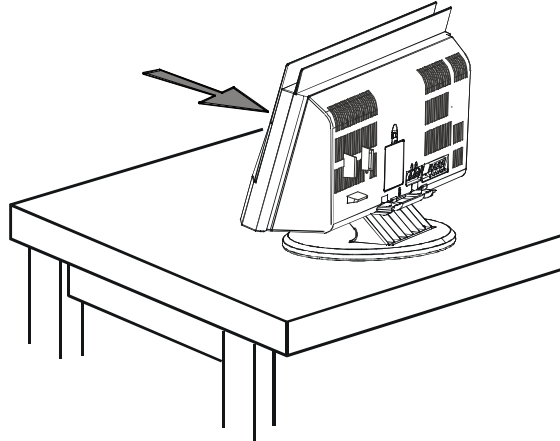

If you ever need to remove the main unit from the pedestal:

- 1.) Place the entire unit face down on a flat surface.

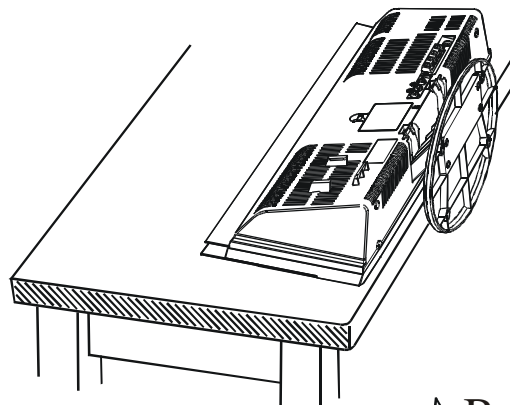

- 2.) (A) Depress the two pedestal locking tabs to release the pedestal.

(B) Slide the pedestal upward to completely remove it from the main unit.

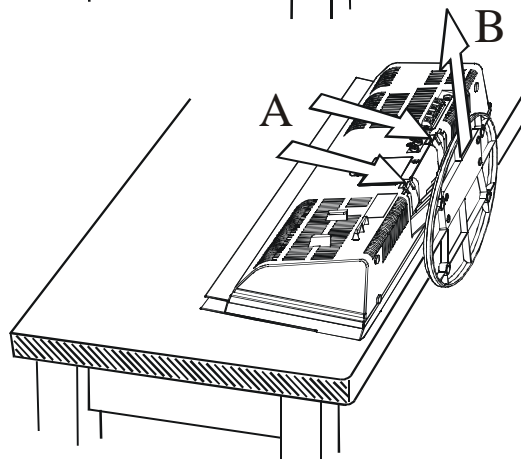

6



Installing The Back Up Batteries

This system includes a battery back up circuit that will maintain the tuner preset station memories, the clock time, and the timer settings in the event of a temporary power interruption. The battery back up system requires three “AA” batteries, not included. Please use a well-known brand of alkaline batteries for longest life and most reliable performance.

The back-up battery compartment is located on the backside of the main unit.

- 1.) Press down on the battery door-locking tab as shown and remove the door.

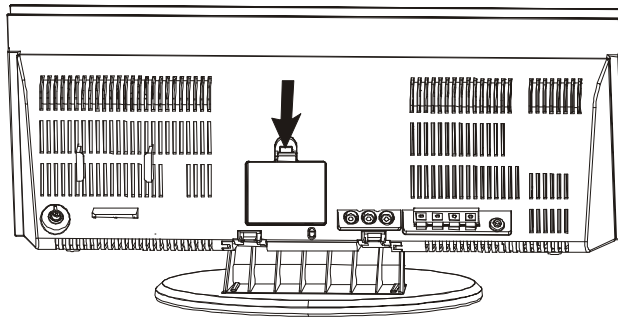

- 2.) Install 3 fresh “AA” alkaline batteries in the battery compartment. Be sure to install the batteries correctly, according to the polarity (+ / -) markings inside the battery compartment.

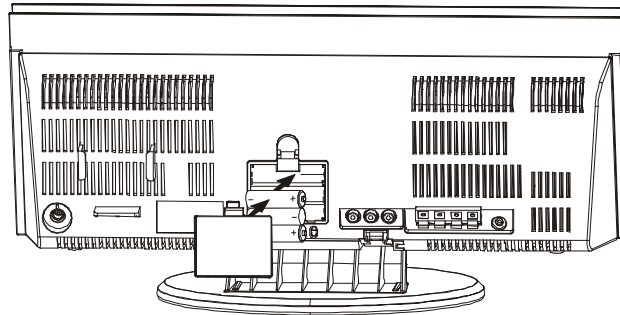

- 3.) Replace the battery door.

Note: *The life expectancy of the back up batteries will depend on the number and the length of the power interruptions that you experience. Under normal circumstances we recommend that you replace the back up batteries every 12 months.*



Remote Control Battery

The remote control requires one “button-type” 3-volt lithium battery, included. To extend the life of the original battery we have inserted a small clear plastic spacer tab between the lithium battery and the battery terminal.

You must remove this battery spacer tab before you can use the remote control.

To remove the tab, pull it in the direction of the arrow in the illustration as shown.

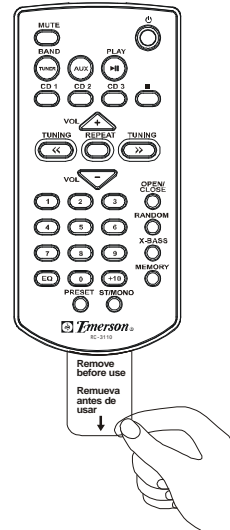

When the operation of the remote control becomes intermittent or unsatisfactory, replace the original battery with a new 3-volt lithium battery.

The battery number is **CR2025** or equivalent.

To replace the battery, slide the battery holder out of the remote control as shown in the following illustration.

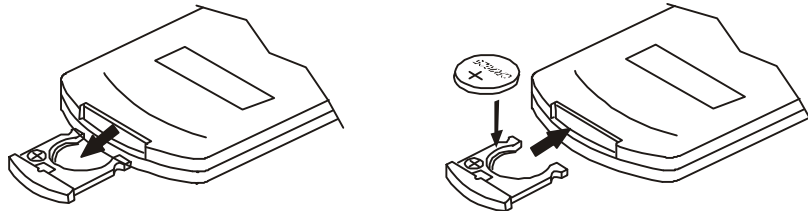

Remove the original battery from the holder and install a new **CR2025** battery with the “+” side facing up as shown in the illustration. Then slide the battery holder back into the remote control.

Dispose of the original battery properly. It should not be thrown into a fire as the battery may explode if incinerated. It should not be left around where small children or pets might play with, or swallow it. If the battery is accidentally swallowed, contact a physician immediately.



Remote Control Storage

For your convenience we have included a remote control handset holder on the back cabinet of the main unit.

To avoid misplacing the handset we suggest that you store it in this holder when not in use.

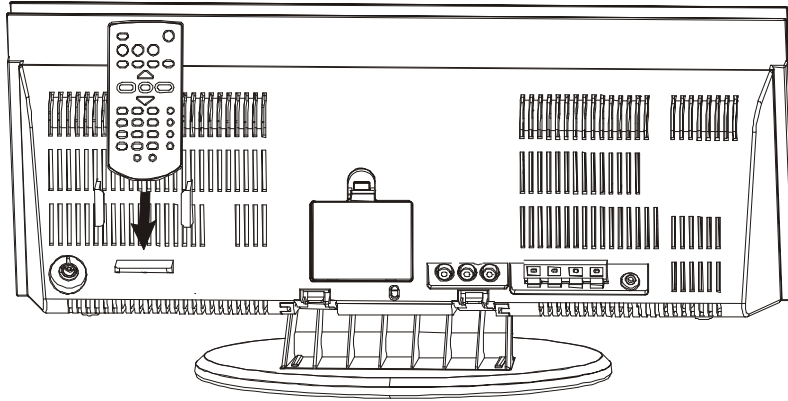

Battery Precautions

- Replacement of batteries must be done by an adult.
- Do not mix old and new batteries.
- Do not mix alkaline, standard (carbon-zinc) or rechargeable (nickel-cadmium) batteries.
- The supply terminals are not to be short-circuited.
- Non-rechargeable batteries are not to be recharged.
- Exhausted batteries are to be removed.
- Only batteries of the equivalent type are to be used.
- Batteries are to be inserted with the correct polarity.
- Dispose of batteries properly. Do not dispose of batteries in fire. The batteries may explode or leak.



Connecting The Speakers

Note: Always connect the speakers before switching the power 'On', and never operate the system without the speakers properly connected.

The speaker cables and the speaker terminals are color-coded.

Connect the Black with Gray dashes wires to the Red terminals.

Connect the Black wires to the Black terminals. If the wires are connected incorrectly the sound will be "muddy" or distorted.

To make the connection, completely depress the plastic levers to open the terminals, insert the bare end of the speaker wire into the terminal openings, and release the plastic levers to lock the wires in place.

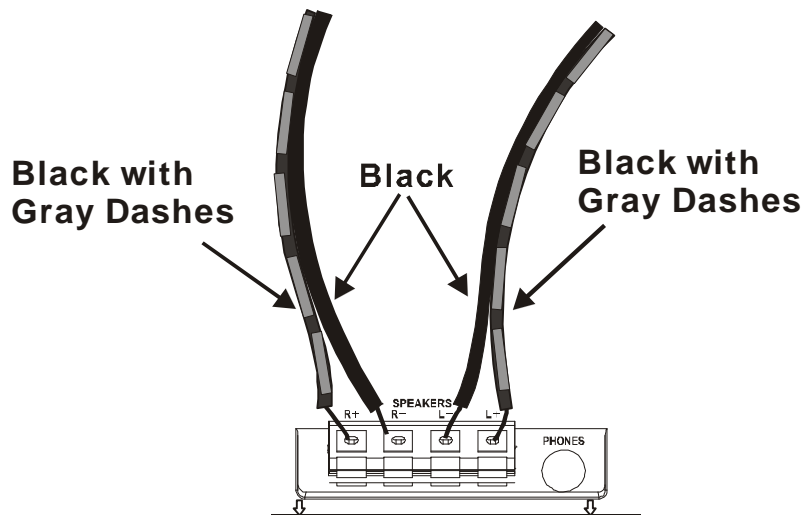
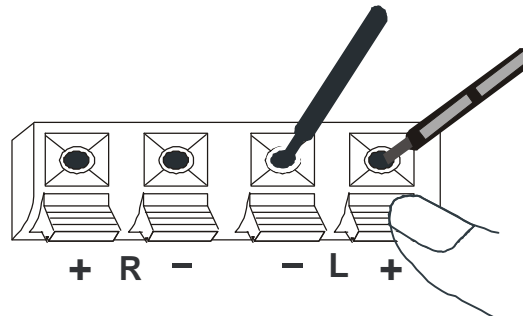



Active Subwoofer Output Jack

This system includes an output jack for the connection of an optional active/powerd subwoofer. The subwoofer must have its own power supply and AC power cord. You cannot use a passive/un-powered subwoofer.

Connect your active subwoofer to the **SUB-WOOFER** output jack on the back panel of this system. Connect the subwoofers AC power cord to your AC outlet, set the subwoofer power switch 'On' and adjust the subwoofers level control to the desired setting.

When you operate this system the low frequencies will be sent to the external powered subwoofer for a more powerful bass sound.

Note: *the remote controller of this system cannot control the external subwoofer. You must remember to switch the external subwoofer 'On' and 'Off', and adjust the subwoofer output manually.*

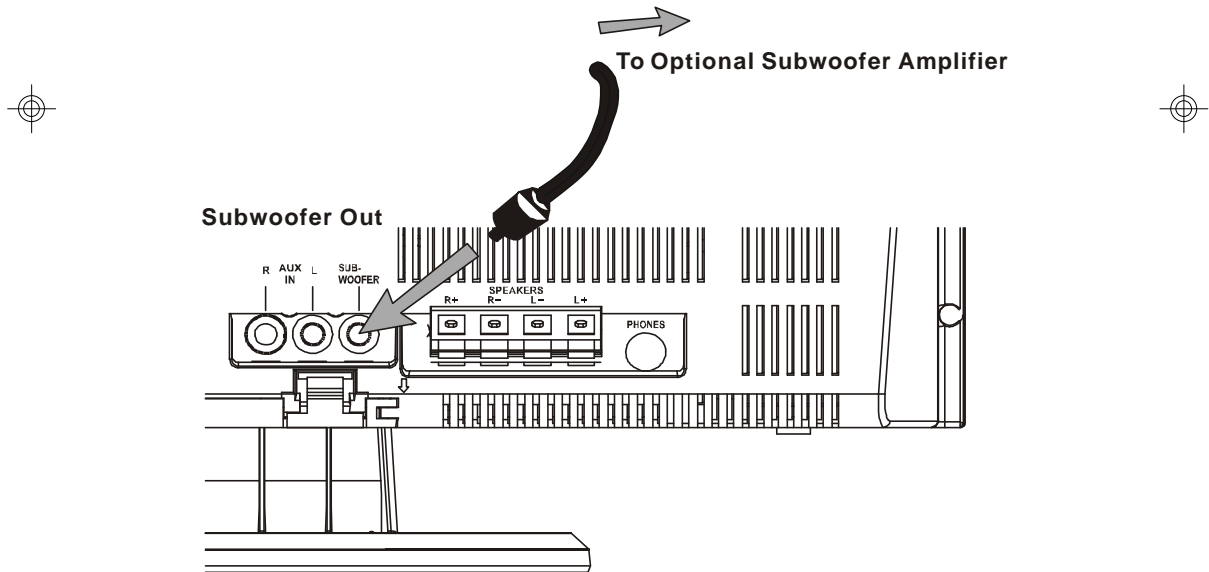

Auxiliary Input Jacks

This system includes **AUX IN R/L** Jacks. These jacks allow you to connect external audio equipment to this system and listen to the sound from the external equipment through the speakers of this system.

Examples of the types of external equipment that may be connected are: a cassette deck; the audio outputs from a VCR or DVD player; a personal cassette player, MP3 player, MD player, or a personal hard-disc audio jukebox device such as an iPod®.

Connect the audio output jack(s) or headphone jack of the external audio equipment to the **AUX IN R/L** jacks on the back panel of this system.

CONNECTION CABLES ARE NOT INCLUDED.

You may leave your external device permanently connected to this system if you wish. It is not necessary to disconnect the external device in order to listen to the Tuner or CD player in this system.

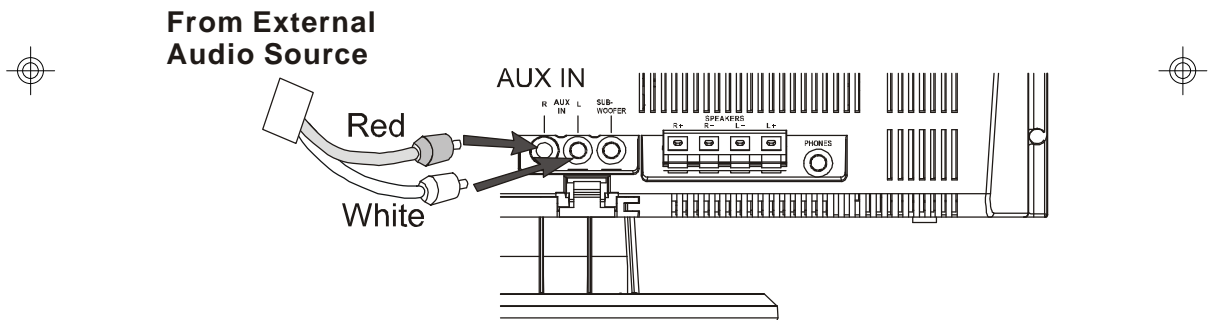

Instructions for listening to your external device will be found at the end of this Owner's Manual.



Stereo Headphone Jack

This system includes a stereo **PHONES** jack on the back panel of the main unit. You may connect a set of stereo headphones, not included, to this jack for private listening without disturbing others.

The main speakers are automatically shut off when headphones are connected to the **PHONES** jack. Make sure that the plug from your headphones is fully inserted into the headphone jack. If the plug is not fully inserted the sound may be intermittent, or you may only hear sound from one side of the headphones.

***IMPORTANT:** To prevent hearing damage always set the volume control to a low level before you connect the headphones. Then connect the headphones, put them on, and very gradually increase the volume to a comfortable listening level. Remember that CDs may contain both very soft and very loud passages. Adjust the volume to a comfortable level using a louder passage, so that you always know what the maximum level will be.*

Placement Of The System

The system should be placed on a stable, level surface such as a table, shelf, or stand, convenient to a 120V 60Hz AC outlet, out of direct sunlight, and away from sources of excess heat, dust, moisture, or vibration.

The speakers may be separated from the main as far the wires allow for maximum stereo separation, or they may be placed to the immediate left and right of the main unit. However to avoid interfering with the operation of the CD door the speakers should not be placed directly against the main unit. Always leave a gap of at least 1/2 inch between the speakers and the main unit.

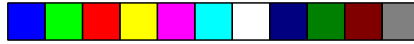

Power Source

This system is designed to operate on 120V AC 60Hz house current only. Connecting this system to any other power source may cause damage to the system and such damage is not covered by your warranty.

NOTE: The system has polarized AC plug with one wide blade and one narrow blade. The plug will only fit into matching polarized AC outlets.

This is a safety feature to reduce the possibility of electric shock. If the plug will not fit in your AC outlets, you probably have outdated non-polarized outlet. You should have your outdated outlet changed by a qualified, licensed electrician. Do not file the wide blade on the plug, or use an adapter to make the plug fit into your outlet. This defeats the safety feature and could expose you to electric shock.

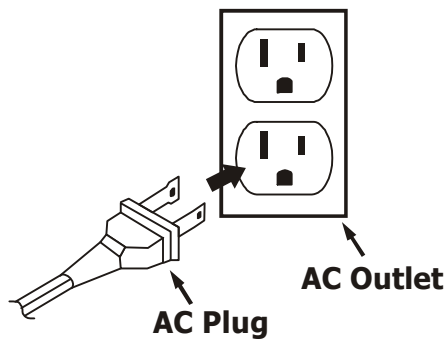

Protect Your Furniture

This model is equipped with non-skid rubber 'feet' to prevent the product from moving when you operate the controls. These 'feet' are made from non-migrating rubber material specially formulated to avoid leaving any marks or stains on your furniture. However certain types of oil based furniture polishes, wood preservatives, or cleaning sprays may cause the rubber 'feet' to soften, and leave marks or a rubber residue on the furniture. To prevent any damage to your furniture we strongly recommend that you purchase small self-adhesive felt pads, available at hardware stores and home improvement centers everywhere, and apply these pads to the bottom of the rubber 'feet' before you place the product on fine wooden furniture.

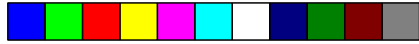

LOCATION OF CONTROLS AND INDICATORS

FRONT PANEL

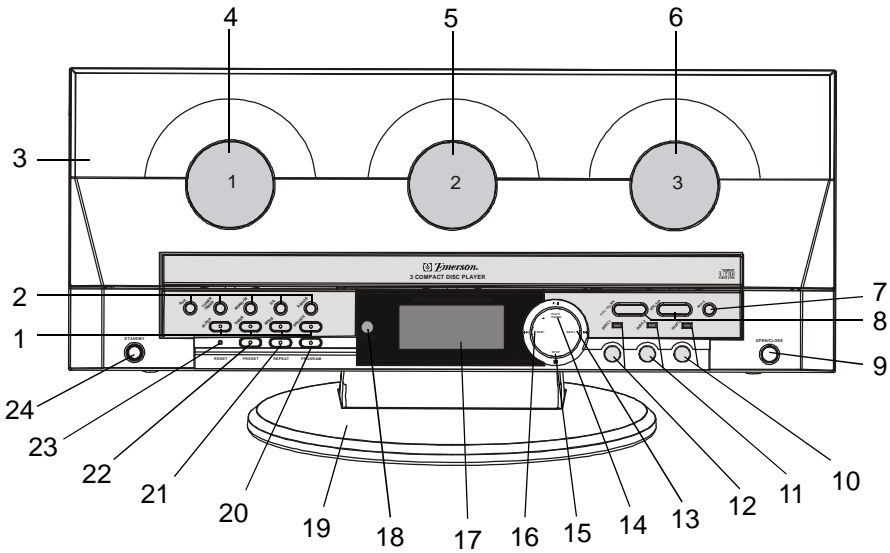

BACK PANEL

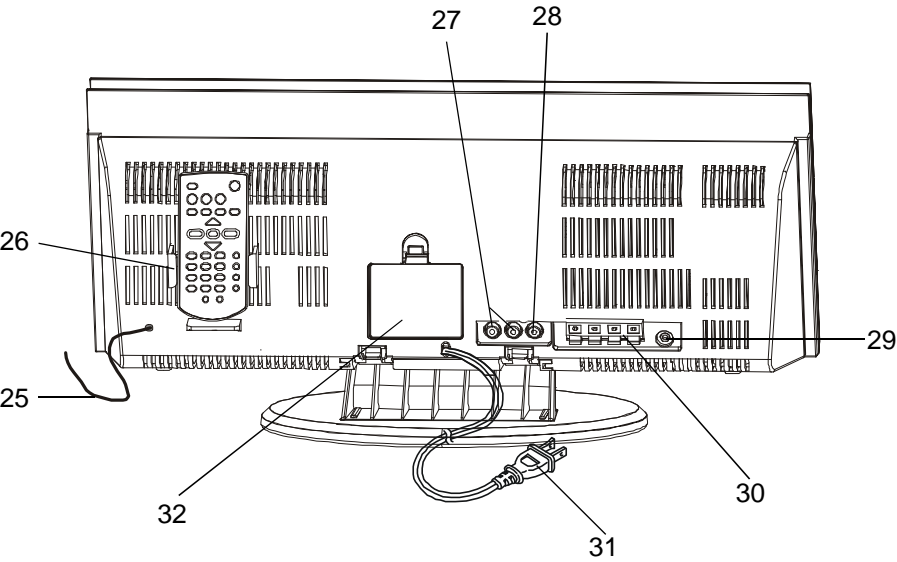

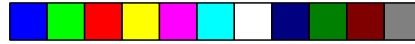

- 1.) **SLEEP / TIMER / MODE / SNOOZE** Buttons.
- 2.) **AUX / TUNER-BAND / MONO-ST / EQ / X-BASS** Buttons.
- 3.) CD Door.
- 4.) DISC 1 Tray.
- 5.) DISC 2 Tray.
- 6.) DISC 3 Tray.
- 7.) MUTE Button.
- 8.) **VOL-DOWN / VOL-UP** Buttons.
- 9.) CD Door **OPEN/CLOSE** Button.
- 10.) **DISC 3** Indicator & Play Button.
- 11.) **DISC 2** Indicator & Play Button.
- 12.) **DISC 1** Indicator & Play Button.
- 13.) **SKIP + (▶▶)** Button.
- 14.) **PLAY/PAUSE ▶||** Button.
- 15.) **STOP ■** Button.
- 16.) **SKIP – (◀◀)** Button.
- 17.) **MULTI FUNCTION DISPLAY.**
- 18.) Remote **SENSOR.**
- 19.) Pedestal Stand.
- 20.) **PROGRAM** Button.
- 21.) **REPEAT** Button.
- 22.) **PRESET** Button.
- 23.) **RESET** Button (Inside Pin Hole).
- 24.) **STANDBY** Button.
- 25.) FM Lead Wire Antenna.
- 26.) Remote Control Storage.
- 27.) **AUX IN R/L** Jacks.
- 28.) **SUFWOOFER** Out Jack.
- 29.) **PHONES** Jack.
- 30.) Speaker Terminals.
- 31.) AC Power Cord.
- 32.) Back Up Battery Compartment.

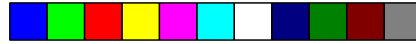

REMOTE CONTROL

- 1.) **PRESET** Button.
- 2.) **EQ** Button.
- 3.) Numeric Buttons.
- 4.) **VOL -** Button.
- 5.) **TUNING <<** Button.
- 6.) **VOL +** Button.
- 7.) **CD 1/CD 2/CD 3** Buttons.
- 8.) **TUNER/BAND** Button.
- 9.) **MUTE** Button.
- 10.) **AUX** Button.
- 11.) **IR (Infrared) Transmitter**.
- 12.) **Standby On/Off** Button.
- 13.) **PLAY/Pause** Button.
- 14.) **Stop** Button.
- 15.) **TUNING >>** Button.
- 16.) **REPEAT** Button.
- 17.) **CD Door OPEN/CLOSE** Button.
- 18.) **RANDOM** Button.
- 19.) **X-BASS** Button.
- 20.) **MEMORY** Button.
- 21.) **ST/MONO** Button.
- 22.) **Battery Compartment**.

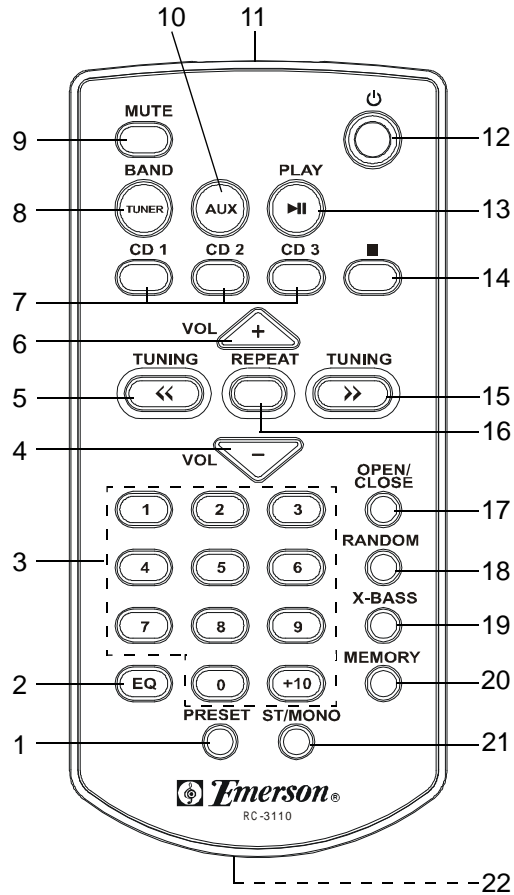



OPERATING INSTRUCTIONS

- **Make sure that you have fully extended the FM antenna wire.**
- **Make sure that you have removed the battery spacer from the remote control handset.**
- **Make sure that you have installed 3 “AA” batteries in the main unit battery back up compartment.**
- **Make sure that the system is connected to an AC outlet that is always “live”.**

Do not connect the system to an AC outlet controlled by a wall switch.

Remove The Dummy CD Transit Protection Cards

This system was shipped with a “dummy CD” transit protection card in each of the 3 CD players. These cards were inserted to prevent the CD player mechanisms from moving during shipping and handling. They must be removed and discarded before you can load your own CDs. After connecting the system to your AC outlet, press the STANDBY button to turn the system ‘On’. Then press the **OPEN/CLOSE** button to open the CD door. Remove the 3 “dummy CDs” and discard them.

Press the **OPEN/CLOSE** button to close the CD door.

General Controls

Most of the main functions of this system can be operated by the controls on the front panel of the main unit, or by the buttons on the remote control handset. If a specific function can only be operated by the remote handset, or by the front panel controls, this will be clearly indicated in the instructions.

When operating this system with the remote control handset make sure that the IR (Infrared) transmitter on the front of the remote handset is pointed at the remote sensor on the front panel of the main unit. The effective operating range of the remote control is approximately 15 feet. Please note that bright sunlight or room lighting may interfere with the remote control operation. If the remote is not operating properly try reducing the brightness of the room or moving closer to the main unit. If this does not solve the problem, it may be time to change the remote control battery.



Volume Controls

To increase or decrease the system volume press the **VOL DOWN (-)** or **VOL UP (+)** buttons on the front panel or the remote control. The Volume Level Indicator will appear on the display when you change the volume level. The level indicator ranges from “0” (Minimum) to “60” (Maximum). The system remembers the volume level when the power is switched ‘Off’ and automatically returns to the same level when the power is switched ‘On’ again.

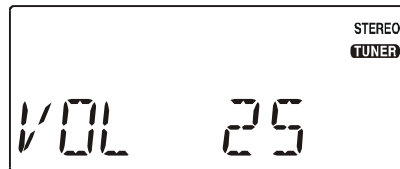

Bass Boost Control (X-BASS)

To increase the bass response, press the **X-BASS** button on the main unit or on the remote control.

The **XBASS** indicator appears in the display. Press again to cancel the X-BASS and return to normal bass response. The **XBASS** indicator goes ‘off’.

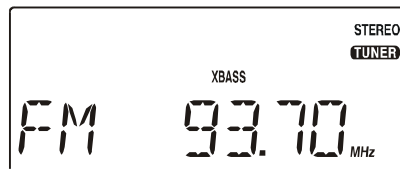

Electronic Preset Equalizer (EQ)

The preset equalizer allows you to adjust the sound characteristic for the most popular types of music.

Press the **EQ** button on the front panel or the remote control to cycle through the following equalizer settings: **FLAT** (EQ ‘Off’), **POP**, **ROCK**, **JAZZ**, or **DISCO**.

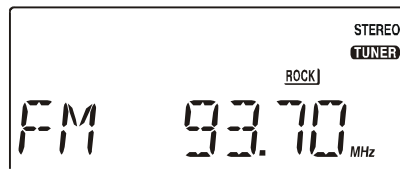

The appropriate EQ indicator appears in the display to confirm your selection. The system remembers the EQ setting when the power is switched ‘off’ and returns to the same setting when the power is switched ‘on’ again.



FM Mono/Stereo Mode Switch (MONO/ST)

If you are listening to a weak or distant FM stereo station you may be able to improve the reception by pressing the **MONO/ST** Mode button to select the FM Mono mode. The **STEREO** indicator will go off. The reception will normally improve but the sound will no longer be in stereo. Under normal circumstances this switch should be left in the FM ST Mode.



Note: This switch has no effect when playing CDs or listening to external sources connected to the **AUX IN** jacks.

MUTE Button

Press the **MUTE** button on the front panel or the remote control to shut off the speakers temporarily, for example, to answer the telephone.

The sound stops and the **MUTE** indicator appears in the display.

Press the **MUTE** button again to cancel the mute function and restore the sound. The **MUTE** indicator disappears.

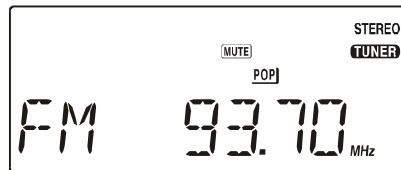

The mute function will also be canceled automatically by pressing the **VOL DOWN** (–) or **VOL UP** (+) buttons

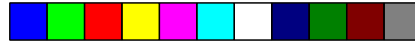

Setting The Clock

When the system is connected to an AC outlet the time display will show a flashing “12:00 AM” and the “**CLOCK**” indicator appears.

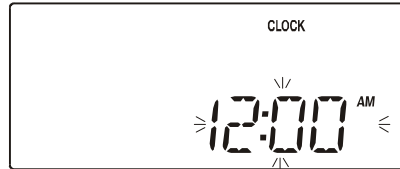

This is your indication that the time is incorrect and needs to be set.

Note: Although it is not necessary to set the clock in order to listen to the radio or CD player, the clock must be set correctly if you intend to use the timer to turn the system ‘On’ and ‘Off’ automatically.

Set the clock as follows:

- 1.) Press the **PROGRAM** button on front panel or **MEMORY** button on remote control once. The ‘Hour’ digits begin flashing.

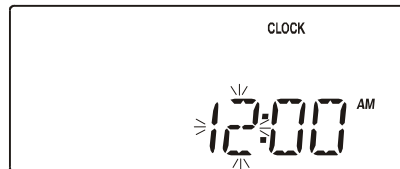

- 2.) Repeatedly press the **SKIP – (⏮)** / **SKIP + (⏭)** buttons on front panel or **TUNING << / TUNING >>** buttons on remote control to adjust the display to the correct hour, **AM** or **PM**.

- 3.) Press the **PROGRAM** or **MEMORY** button again to set the hour.
The ‘Minute’ digits begin to flash.

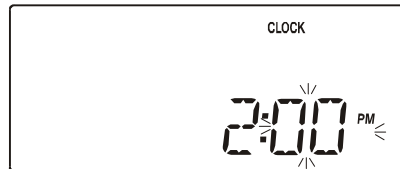

- 4.) Repeatedly press the **SKIP – (⏮)** / **SKIP + (⏭)** buttons on front panel or **TUNING << / TUNING >>** buttons on remote control to adjust the display to the correct minute.

- 5.) Press the **PROGRAM** or **MEMORY** button again to set the minutes. Only the colon “:” continues flashing.

The clock begins to run.

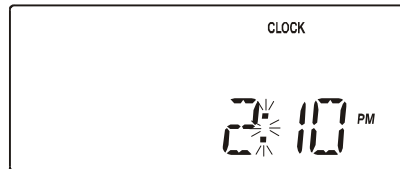



Notes:

- After pressing the **PROGRAM** or **MEMORY** button to begin setting the clock, you must press the **SKIP - (⏪)** / **SKIP + (⏩)** or **TUNING << / TUNING >>** buttons to adjust the display within 10 seconds, otherwise the digits stop flashing and the time cannot be adjusted. If this occurs, press the **PROGRAM** or **MEMORY** button again and then press the **SKIP - (⏪)** / **SKIP + (⏩)** or **TUNING << / TUNING >>** buttons within 10 seconds to adjust the display.
- The display will always show the time when the system is in the Standby (Off) or AUX mode.
- To see the time while the system is in the Tuner or CD mode, press the **MODE** button on the front panel (there is no MODE button on the remote control).
- The display will show the correct time for approximately 10 seconds and then return to the Tuner or CD display mode.





Listening To The Radio

- 1.) Press the **STANDBY**  button to turn the system 'On'.

The display shows "HELLO".



- 2.) Press the **TUNER/BAND** button to select the Tuner function.



An **AM** or **FM** frequency will appear on the display.

Press the **TUNER/BAND** button again to switch between the AM and FM bands if necessary.





- 3.) Tune to the desired station as follows:

- **Manual Tuning**

Repeatedly press the **SKIP -** () / **SKIP +** () or **TUNING <<** / **TUNING >>** buttons until the display shows the exact frequency of the desired station. Use the Manual Tuning method to tune to weak or distant stations that are not strong enough to be recognized by the Automatic Tuning system.

- **Automatic Tuning**

Depress and hold the **SKIP -** () / **SKIP +** () or **TUNING <<** / **TUNING >>** buttons until the display begins to move, then release the buttons. The Tuner will search up or down the band for the next strong signal and stop on that station. Repeat this procedure until the tuner stops on your desired station.

- 4.) If you tuned to an FM Stereo station the **STEREO** indicator will appear in the display. If the FM Stereo reception is noisy or weak, press the **MONO/ST** button to select the FM Mono mode.

- 5.) Adjust the **VOLUME**, **EQ**, and **X-BASS** controls to the desired settings.

- 6.) When you are finished listening press the **STANDBY**  button to return the system to the Standby (Off) mode.

The display changes from radio frequency to correct time.

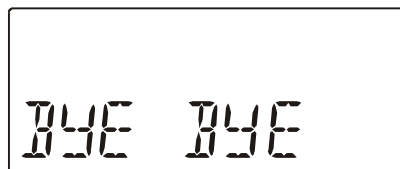

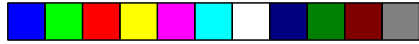

Hints For Better Reception

FM: The FM lead wire antenna on the back panel should be extended to its full length. You may also have to vary the direction of this antenna until you find the position that provides the best reception.

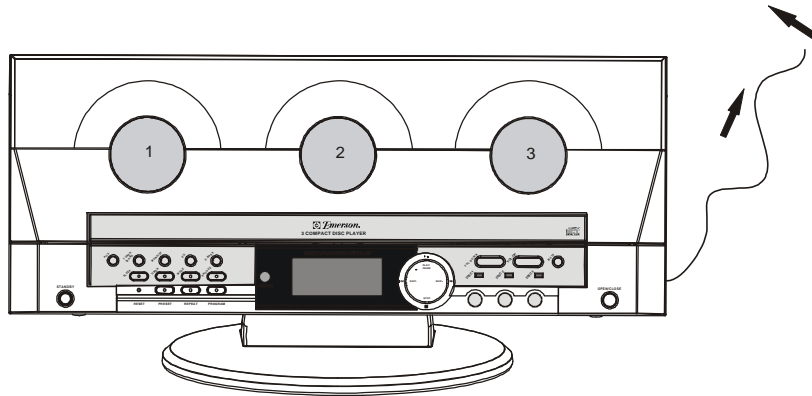

AM: The AM bar antenna is inside the cabinet of the main unit. You may need to change the position of the main unit until you find the position that provides the best reception for your favorite AM stations.

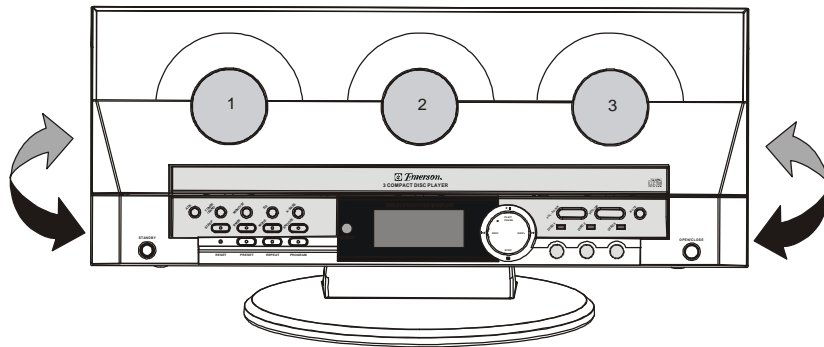



Presetting Stations In The Tuner Memory

You can store up to **32** of your favorite stations (**16 FM/16 AM**) in the tuner memory for easy recall at any time.

Using either the manual or automatic tuning method described above, tune to the first station you wish to memorize (Example: **FM 103.5**) and then:

- 1.) Press the **PROGRAM** or **MEMORY** button.

The display shows preset memory "**01**" and the **MEMORY** indicator flashes.



- 2.) Press the **PROGRAM** or **MEMORY** button again to enter your station in preset memory "01".

The flashing **MEMORY** indicator disappears but the preset memory number "**01**" remains in the display, confirming that your station has been entered in preset memory number 1.

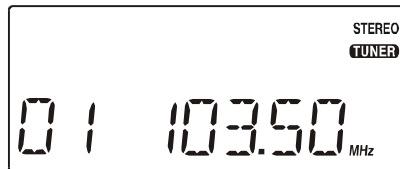

- 3.) Tune to the next station you wish to memorize (Example: **FM 106.7**) and press the **PROGRAM** or **MEMORY** button.

The **MEMORY** indicator flashes and the preset memory number advances to "**02**".

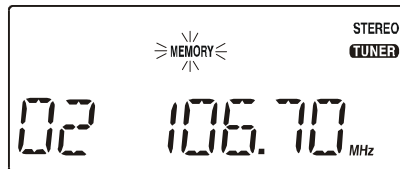

Press the **PROGRAM** or **MEMORY** button again to enter your station in preset memory number 2.

- 4.) Repeat Step 3 until you have stored up to 16 stations on the **FM** band, then press the **TUNER/BAND** button to switch to the **AM** band and follow the same procedure to enter up to 16 AM station in the tuner memory.

Note: After you press the **PROGRAM** or **MEMORY** button the first time, you must press it again within 5 seconds, while the **MEMORY** indicator is flashing on the display, or your station will not be memorized.

If the **MEMORY** indicator stops flashing press the **PROGRAM** or **MEMORY** button once to start the indicator flashing again, then press **PROGRAM** or **MEMORY** again to memorize your station.



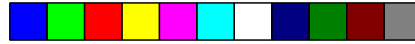

Recalling Preset Stations

- 1.) Turn the system 'On', press the **TUNER/BAND** button to select the Tuner function and the desired band.
- 2.) Press the **PRESET** button repeatedly until the desired preset number and frequency appears on the display.

- You may also use the number buttons on the remote control to directly select the desired preset memory number.
- Simply press the corresponding number key on the remote handset to select preset memory numbers **1** through **9**.
- To select preset memory numbers 10 through 16, first press the “**+10**” button and then the desired second digit.

For example, to select preset memory number 10, press the “**+10**” button and then the “**0**” button.

To select preset 16, press the “**+10**” button and then the “**6**” button.

Changing Preset Stations

- 1.) Tune to the new station you want to memorize and press the **PROGRAM** or **MEMORY** button to start the **MEMORY** indicator flashing.
- 2.) Repeatedly press the **PRESET** button until the display shows the number of the preset memory you wish to change.
- 3.) Press the **PROGRAM** or **MEMORY** button again. The new station is entered in the memory and the previous station is deleted.



Playing Compact Discs

IMPORTANT:

This CD player can play normal CDs plus CD Recordable (CD-R) and CD Rewriteable (CD-RW) discs. However the playability of CD-R/RW discs may be affected by the type of software that was used in 'ripping' the tracks from the original discs and 'burning' the tracks onto the blank media. Playability may also be affected by the quality and condition of the blank media you use for recording. 100% compatibility cannot be guaranteed. This is not an indication of any problems with your player.

Normal Playback

- 1.) Press the **STANDBY**  button to turn the system 'On'.
- 2.) Press the **OPEN/CLOSE** button to open the CD door. If you have not already done so, remove the 3 "dummy CD" transit protection cards and discard them. You cannot play your own CDs unless these cards are removed.
- 3.) Load 1, 2, or 3 of your own CDs into the player with the printed 'labels' facing you.

Gently press downward on each CD near the center hole to insure that the discs are properly 'seated' on the spindles.

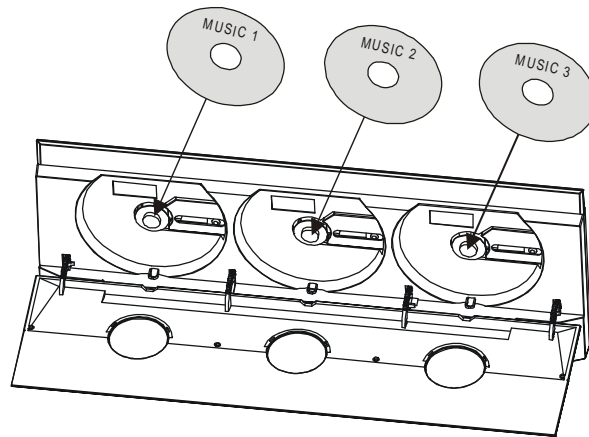



- 4.) Press the **OPEN/CLOSE** button to close the CD door.

The display will show "**TOC READ**" as the player reads the Table Of Contents on each disc. As it reads each disc the display will briefly show the total tracks and playing time on each disc.

After reading the last disc the display will again show the total tracks and playing time of DISC 1. The Disc1 indicator will flash in the display.



Note: It may take 15 to 20 seconds for the player to read the TOC of all 3 discs. The reading time may be even longer if you are using CD-RW (re-write able) discs. This is normal and not an indication of any problem with your unit.

- 5.) To play Disc 1, press the **PLAY/PAUSE** ►|| button or press the **DISC (CD) 1** button.

To start playback with Disc 2 or Disc 3, press the **DISC (CD) 2** or **DISC (CD) 3** buttons. The corresponding **DISC** indicator on front panel lights up.



The Play indicator ► appears in the display.

- 6.) When playback begins, adjust the **VOLUME**, **EQ**, and **X-BASS** controls as desired.



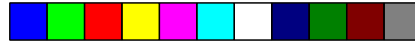

- 7.) Playback will continue until all tracks on all discs have been played, then the player stops and the display shows the total tracks number and playing time on the last disc played.

To stop playback at any time, press the **STOP** ■ button.

- 8.) If you are finished listening, press the **OPEN/CLOSE** button to open the CD door, remove your discs from the player, re-close the door and press the **STANDBY** ⏻ button to return the system to the Standby (Off) mode.















Pause Control

To pause temporarily during CD playback press the **PLAY/PAUSE**  button again. The sound stops and the Pause indicator  flashes in the display, but the disc continues spinning. Press the **PLAY/PAUSE**  button once more to cancel Pause mode and resume playback at the same point. The Pause indicator  disappears.



Skip Track and High Speed Music Search

- During playback, repeatedly press the **SKIP -** () / **SKIP +** () or **TUNING**  / **TUNING**  buttons to skip to higher or lower numbered tracks. Playback will begin on the selected track.
- During playback, depress and hold the **SKIP -** () / **SKIP +** () or **TUNING**  / **TUNING**  buttons to search within a track at high speed to locate a specific musical passage. Release the **SKIP -** () / **SKIP +** () or **TUNING**  / **TUNING**  buttons when you hear the desired passage. Normal speed playback will resume at that point.



Repeat Playback

The Repeat function in this system allows you to continuously repeat a single track, a single disc, or all discs in the player. The Repeat function can be activated during playback or while the player is stopped.

One Track Repeat

Select the track to be repeated and begin playback.

Press the **REPEAT** button once.

The **REPEAT** indicator appears in the display and the selected track will be repeated continuously.



One Disc Repeat

Select the disc to be repeated and begin playback.

Press the **REPEAT** button twice.

The **REPEAT ALL** indicator appears in the display and all the tracks on the selected disc will be repeated continuously.



All Discs Repeat

Load 2 or 3 disc in the player and begin playback.

Press the **REPEAT** button three times.

The **REPEAT ALL DISC** indicator appears in the display. All tracks on all discs in the player will be repeated continuously.



To cancel Repeat playback mode press the **REPEAT** button until all Repeat indicators disappear from the display.

Repeat mode can also be canceled by opening the CD door, switching to the Tuner or Aux mode, or pressing the **STANDBY**  button to return the system to the Standby (Off) mode.



Random Playback (Remote Control Only)

The Random playback feature allows you play all the tracks in random order of the selected disc in the player. After finish playing the selected disc, it skips to the next disc, and so on. It stops when all tracks of the discs are randomly played.

You can select random playback while the discs are playing or when the player is stopped.

Load up to 3 CDs in the player as usual and then press the **RANDOM** button on the remote control handset.

Note: *There is no random button on the front panel of the main unit.*

The **RANDOM** indicator appears in the display.

If necessary, press the **PLAY/PAUSE** ►|| button to begin playback.

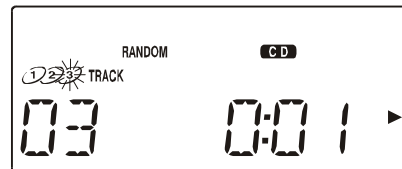

The player will randomly select a track from among the discs and begin playback. Random playback will continue until all tracks have played once, then the player stops.

To cancel random playback, press the **STOP** ■ button. Or press the **RANDOM** button on the remote control again. The **RANDOM** indicator disappears and normal playback will resume from that point.



Programmed Playback

The Programmed Playback feature allows you to program a total of up to **40** tracks from among all 3 discs for playback in any desired order. You may program the same track to play several times within a program sequence if desired.

Note: You cannot program tracks during playback. If a disc is playing press the **STOP ■** button first to stop playback before beginning the programming steps below.

1.) Load up to 3 discs in the player and wait until the player has read the Table of Contents of all discs.

2.) Press the **PROGRAM** or **MEMORY** button.

The **MEMORY** indicator will flash and the display will show Disc 1, Track 01 and Program Memory **P-01**.

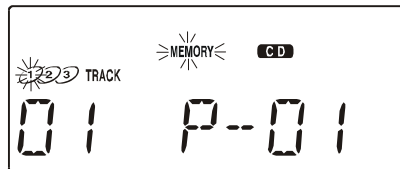

3.) Press one of the **DISC (CD)** buttons to select the disc that contains the first track to be programmed. (Example: Disc 3).

Then press the **SKIP - (⏮)** / **SKIP + (⏭)** or **TUNING << / TUNING >>** buttons to select the first track on that disc to be programmed. (Example: Track 07).

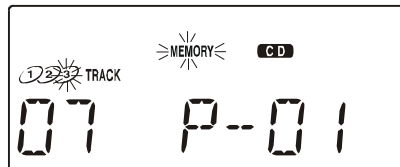

4.) Press the **PROGRAM** or **MEMORY** button again to enter DISC 3 / Track 07 in program memory. The program memory number advance to "**P - 02**".

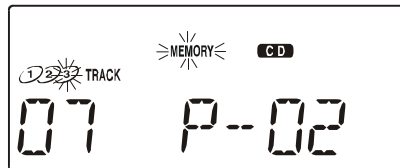

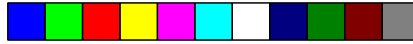

5.) Repeat steps 3 and 4 selecting the desired Disc number and Track number each time until you have entered up to **40** tracks in the CD program memory.

Note: You may also select the track numbers directly with the 1-9 number buttons on the remote control.

- For tracks 1 through 9 simply press the corresponding number button.
- For tracks 10 and higher first press the “+10” button and then the corresponding button for the second digit.
- For track 12, press “+10” and then press “2”.
- For track 23 press “+10” twice, then press “3”.

6.) Press the **PLAY/PAUSE** ►|| button to begin programmed playback.

The **MEMORY** indicator stops flashing and remains on. The player will play the track that you programmed in the desired sequence.

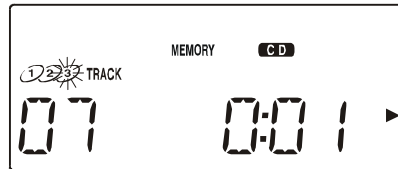

- After the last programmed track has played the player stops, but the **MEMORY** indicator remains on and the programmed sequence remains in the memory.
- To play the programmed sequence again, press the **PLAY/PAUSE** ►|| button.
- To cancel the programmed sequence from the memory press the **STOP** ■ button while the player is stopped. The **MEMORY** indicator disappears.
- The Program sequence can also be cleared from the memory by opening the CD door, switching to Tuner or Aux function, or pressing the **STANDBY** ⏻ button to return the system to the Standby (Off) mode.

Programmed Repeat Playback

You can use the Programmed and Repeat Playback functions together to continuously repeat a programmed sequence.

First program up to 40 tracks as described above, then press the **REPEAT** button three times to select **REPEAT ALL DISC** playback.

Press the **PLAY/PAUSE** ►|| button to begin Programmed Repeat Playback. The programmed sequence will be repeated continuously.

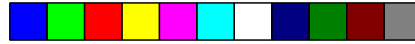

Special Functions

Timer Operation

This system includes a programmable On/Off timer function. You can use the timer to wake you up to the radio or to your favorite CD. The timer can be programmed while the system is in the Standby (Power Off) mode, the Aux mode, the Tuner mode or the CD mode.

To Set The 'ON' Time

- 1.) Press the **MODE** button on the front panel repeatedly until the "TIMER ON" indicator is flashing in the display.

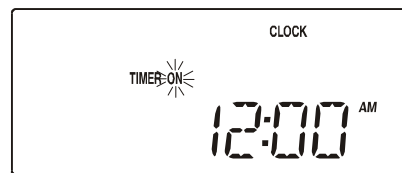

- 2.) Press the **PROGRAM** or **MEMORY** button. The Hour digits begin flashing.

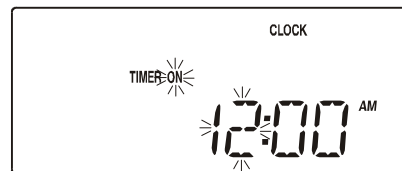

- 3.) Press the **SKIP - (⏮)** / **SKIP + (⏭)** or **TUNING <<** / **TUNING >>** button to set the display to the desired turn on hour, **AM** or **PM**.

- 4.) Press the **PROGRAM** or **MEMORY** button. The Minute digits begin flashing.

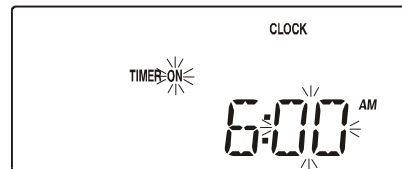

- 5.) Press the **SKIP - (⏮)** / **SKIP + (⏭)** or **TUNING <<** / **TUNING >>** button to set the display to the desired turn on minute.

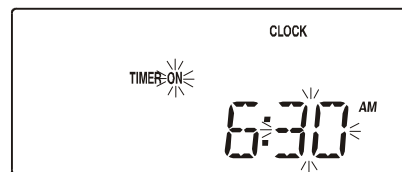

Press **PROGRAM** or **MEMORY** button once again to confirm.

To Set The 'OFF' Time

6.) Press the **MODE** button on the front panel repeatedly until the "TIMER OFF" indicator is flashing in the display.

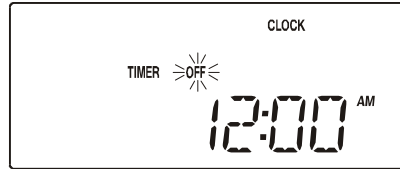

7.) Press the **PROGRAM** or **MEMORY** button. The Hour digits begin flashing.

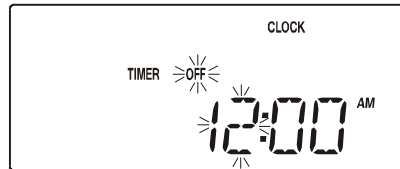

8.) Press the **SKIP - (◀◀)** / **SKIP + (▶▶)** or **TUNING ◀◀** / **TUNING ▶▶** button to set the display to the desired turn off hour, **AM** or **PM**.

9.) Press the **PROGRAM** or **MEMORY** button. The Minute digits begin flashing.

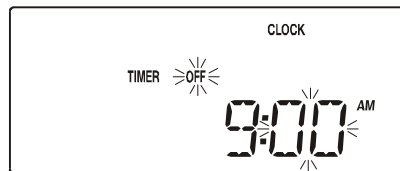

10.) Press the **SKIP - (◀◀)** / **SKIP + (▶▶)** or **TUNING ◀◀** / **TUNING ▶▶** button to set the display to the desired turn off minute.

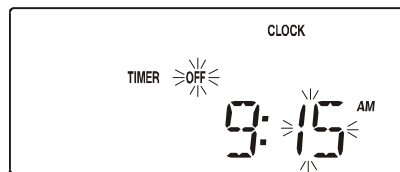

Press **PROGRAM** or **MEMORY** button once again to confirm.

11.) After few seconds, the display returns to correct time.

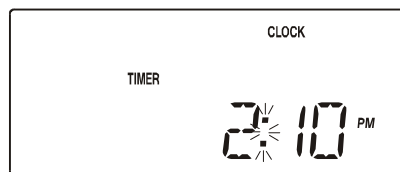

The **TIMER** indicator appears in display meaning that the Timer function is activated.



At the selected "TIMER ON" time the system will turn on automatically to the last function selected, either Tuner or CD.

It will play until it reaches the selected 'Off' time and then shut off automatically.

Note:

If the system turns on to CD function it will only play until the end of the disc and then stop.

If you programmed the system to turn on and play for 3 hours before shutting off, but your CD is only 45 minutes, the system will only play for 45 minutes but the power will remain On for another 2 hours and 15 minutes before shutting Off automatically.

To Deactivate or Activate Timer (On Front Panel Only)

Press the **TIMER** button on front panel to activate or deactivate the Timer function.

SNOOZE Button (On Front Panel Only)

After the system turns on at the selected "TIMER ON" time, you may press the **SNOOZE** button on front panel for a few more minutes sleep.

The "**ByE ByE**" briefly appears, then the power turns 'Off'.

The **SNOOZE** indicator appears in the display.

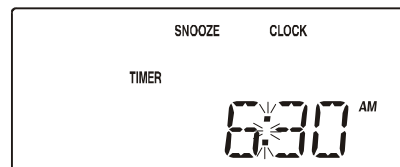

The sound will stop for approximately 9 minutes and then turns 'On' again.

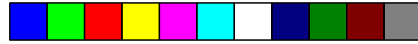

SLEEP Timer (On Front Panel Only)

This system includes a programmable Sleep Timer that allows you to fall asleep to between 10 and 120 minutes of music and then shuts the power 'Off' automatically.

To operate the sleep timer:

- 1.) Turn the system 'On' and operate either the TUNER or CD function as usual.
- 2.) Adjust the **VOLUME** control to the desired level. Remember that the level you select for the sleep to music function is the same level you will hear when the timer turns the system on in the morning.

- 3.) Press the **SLEEP** button on front panel.

The display will show "120" indicating that the sleep timer will shut the power off after 120 minutes.



Continue pressing the **SLEEP** button to decrease the amount of sleep timer operation: **120, 90, 60, 50, 40, 30, 20, 10, 0** minutes.

- 4.) After a few seconds the Sleep Time display disappears and the normal Tuner or CD display returns.

The **SLEEP** indicator remains in the display.

When the Sleep Timer counts down to "00", the power shuts off automatically.

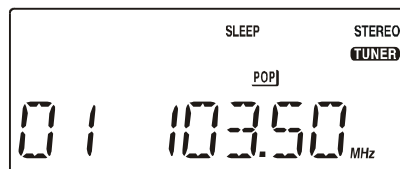

Notes:

- You can shut the unit off manually before the Sleep Timer counts down to "00" by pressing the **STANDBY**  button at any time.
- Remember that if you are falling asleep to CD you will also wake to CD, and if you fall asleep to the Tuner you will also wake to the Tuner.
- If you are falling asleep to CD the system will only operate until the CD ends. If you set the Sleep Timer for 90 minutes but your CD is only 45 minutes long, the music will stop after 45 minutes.

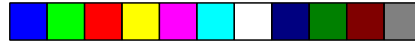

MODE Button

Normally the display shows the correct time in the STANDBY (Power Off) mode, the radio frequency in the TUNER mode, and the CD track and time information in the CD mode. You can press the **MODE** button repeatedly to show the following information on the display:

STANDBY (Power Off) & AUX Modes:

Correct Time ➡ TIMER ON Time ➡ TIMER OFF Time ➡ Correct Time.

TUNER Mode:

Radio Frequency ➡ Correct Time ➡ TIMER ON Time ➡ TIMER OFF Time ➡ Radio Frequency.

CD Playback Mode:

CD Track Elapsed Time ➡ CD Track Remaining Time ➡ CD Track Elapsed Time.

CD Stop Mode:

CD Total Tracks & Time ➡ Correct Time ➡ TIMER ON Time ➡ TIMER OFF Time ➡ CD Total Tracks & Time.

Auxiliary Operation

To listen to an auxiliary audio source connected to the **AUX IN** jacks on the back panel of this unit (refer to page 12).

Press the **AUX** button to select the Aux function.

The **AUX** indicator appears in the display.

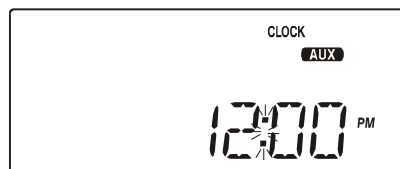

Operate the external device as you would normally. When you hear the music from your external source adjust the **VOLUME**, **EQ**, and **X-BASS** controls of this system as desired.

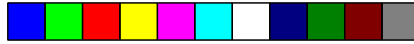

Resetting The System Computer

This system is equipped with a special circuit designed to protect the internal computer from permanent damage due to unexpected power surges.

If you find that the system does not respond to any commands from the front panel controls or the remote handset, the system probably experienced a sudden power surge that activated the protection circuit.

To reset the system after a power surge use the point of a pencil, a toothpick, a straightened paper-clip or similar object to press the **RESET** button which is located in a small opening on the front panel.

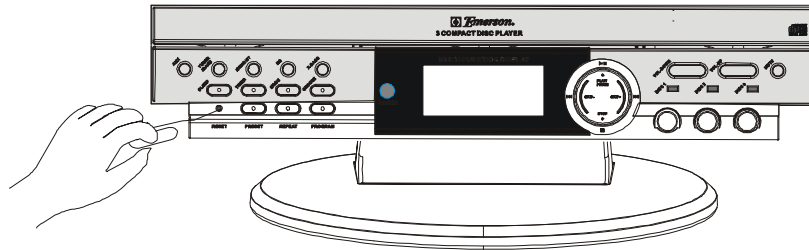

The system will return to the Standby (Off) mode.

Note: *Resetting the system computer also clears all of the system memory and returns the system to its original factory default settings. All of the preset tuner memories, the clock and the timer settings will be erased after you press the **RESET** button. It will be necessary to re-enter the stations in the tuner preset memories, reset the clock and the timer settings.*

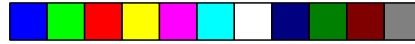

CARE AND MAINTENANCE

Compact Disc Care

- To remove a disc from its storage case, press down on the center of the case and lift the disc out, holding it carefully by the edges.

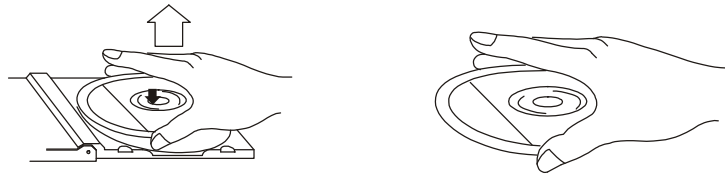

- Fingerprints and dust should be carefully wiped off the disc's recorded surface with a soft cloth. Unlike conventional records, compact discs have no grooves to collect dust and microscopic debris, so gently wiping with a soft cloth should remove most particles. Wipe in a straight line from the inside to the outside of the disc. Small dust particles and light stains will have absolutely no effect on reproduction quality.

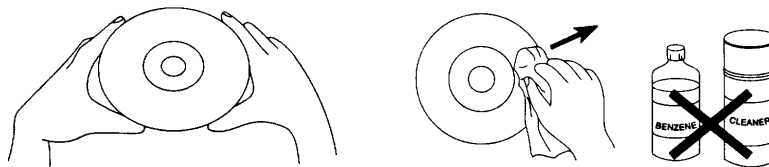

- Clean the disc periodically with a soft, lint-free, dry cloth. Never use detergents or abrasive cleaners to clean the disc. If necessary, use a CD cleaning kit.
- Never write on or affix labels to the surface of compact discs.



Care Of The Cabinet

If the cabinet becomes dusty wipe it with a soft dry dust cloth. Do not use any wax, polish sprays, or abrasive cleaners on the cabinet.

Caution

Never allow any water or other liquids to get inside the unit while cleaning.

 Emerson [®] SERVICE	TO FIND THE LOCATION AND PHONE NUMBER OF YOUR NEAREST SERVICE CENTER PERMITTED TO PERFORM WARRANTY...
CALL TOLL FREE: 1-800-695-0098	
FOR ADDITIONAL SET-UP OR OPERATING ASSISTANCE PLEASE CALL: 1-800-898-9020	
FOR CUSTOMER SERVICE, PLEASE WRITE TO: Emerson Radio Corp., Consumer Affairs Dept., 5101 Statesman Drive, Irving, TX 75063.	



LIMITED WARRANTY

Emerson Radio Corp. warrants manufacturing defects in original material, including original parts and workmanship, under normal use and conditions, for a period of ninety (90) days from the date of original purchase in the U.S. With your dated proof of purchase, we will provide repair service at no charge for labor and parts at an authorized Depot Repair Facility, or replace the product in our discretion. For repair or replacement, pack your unit in a padded box, enclose your check or money order payable to Emerson Radio Corp. in the amount of \$9.00 (not required by California residents) to cover shipping and handling costs, and enclose a copy of your proof of purchase. Send your unit to:

Emerson Radio Corp.,
5101 Statesman Drive,
Irving, TX 75063.

This warranty does not cover damage from negligence, misuse, abuse, accident, failure to follow operating instructions, commercial use, rental, repairs by an unauthorized facility, or products purchased, used, serviced or damaged outside of the United States.

THIS WARRANTY GIVES YOU SPECIFIC LEGAL RIGHTS, AND YOU MAY ALSO HAVE OTHER RIGHTS WHICH VARY FROM STATE TO STATE.

AU898M

The Serial Number can be found on the back cabinet. We suggest that you record the Serial Number of your unit in the space below for future reference.

Model Number: MS3110

Serial Number: _____



EMERSON
Part No. 16-2967
611-03

Printed in China



MS3110_112106.p65

43



22/11/2006, 11:48

