

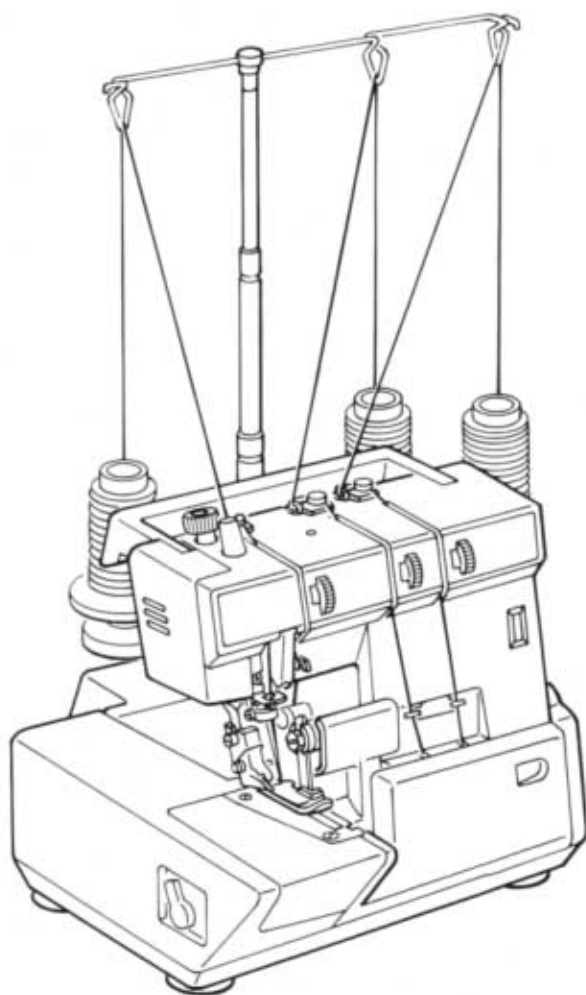

RICCAR®

INSTRUCTION MANUAL



ONE NEEDLE, THREE THREAD

Serger

MODEL **RICCAR®** LOCK RL 603

OWNER'S MANUAL

This sewing machine is intended for household use.

IMPORTANT SAFETY INSTRUCTIONS

When using a sewing machine, basic safety precautions should always be followed, including the following.

Read all instructions before using.

DANGER - To reduce the risk of electric shock:

1. Never leave unattended when plugged in. Always unplug this machine from the electric outlet immediately after using and before cleaning.
2. Always unplug before relamping. Replace bulb with same type and wattage.

WARNING - To reduce the risk of burns, fire, electric shock, or injury to persons:

1. Do not allow to be used as a toy. Close attention is necessary when this sewing machine is used by or near children.
2. Use this sewing machine only for its intended use as described in this manual. Use only attachments recommended by the manufacturer as contained in this manual.
3. Never operate this sewing machine if it has a damaged cord or plug, if it is not working properly, if it has been dropped or damaged, or dropped into water. Return the sewing machine to the nearest authorized dealer or service center for examination, repair, electrical or mechanical adjustment.
4. Never operate the sewing machine with any air openings blocked. Keep ventilation openings of the sewing machine and foot controller free from the accumulation of lint, dust, and loose cloth.
5. Never drop or insert any object into any opening.
6. Do not use outdoors.
7. Do not operate where aerosol (spray) products are being used or where oxygen is being administered.
8. Do not unplug by pulling on cord. To unplug, grasp the plug, not the cord.
9. Keep fingers away from all moving parts. Special care is required around the sewing machine needle and knives.
10. Always use the proper needle plate. The wrong plate can cause the needle to break.
11. Do not use bent needles.
12. Do not pull or push fabric while stitching. It may deflect the needle causing it to break.
13. Always unplug sewing machine from the electrical outlet when making any adjustments in the needle area, such as threading needle or loopers, changing needle, knife, or needle plate.
14. Always unplug sewing machine from the electrical outlet when removing covers, lubricating, or when making any other user servicing adjustments mentioned in this manual.

SAVE THESE INSTRUCTIONS

TABLE OF CONTENTS

SPECIFICATIONS	1	SETTING STITCH LENGTH	12
GETTING TO KNOW YOUR SEWING MACHINE	2	SETTING SEAM WIDTH	12
ACCESS TO THREAD GUIDES AND FREE ARM ...	3	ADJUSTING THE PRESSURE ON FABRIC	12
ACCESSORIES	4	NARROW AND ROLLED HEMMING	13
ELECTRICAL CONNECTION	4	ROLLED OVEREDGE	15
NEEDLE, THREAD AND FABRIC CHART	5	TURNING CORNERS	16
INSERTING THE NEEDLE	5	FREE ARM SEWING	17
THREADING THE MACHINE	6	DECORATIVE OVERLOCK	17
BEFORE STARTING TO SEW	10	CLEANING AND MAINTENANCE	18
OVERLOCK SEWING	11	BEFORE YOU CALL FOR SERVICE	20
REGULATING THE THREAD TENSION	11		

SPECIFICATIONS

Stitch length	1-5 mm
Seam width	3.5-5 mm
Needle bar stroke	27 mm
Presser foot	Hinged
Presser foot lift	5 mm
Needle	BL-1, size #11, #14
Number of threads	3
Dimensions	Width: 290 mm X Depth: 230 mm X Height: 320 mm
Net weight	6.7 kg

GETTING TO KNOW YOUR SEWING MACHINE

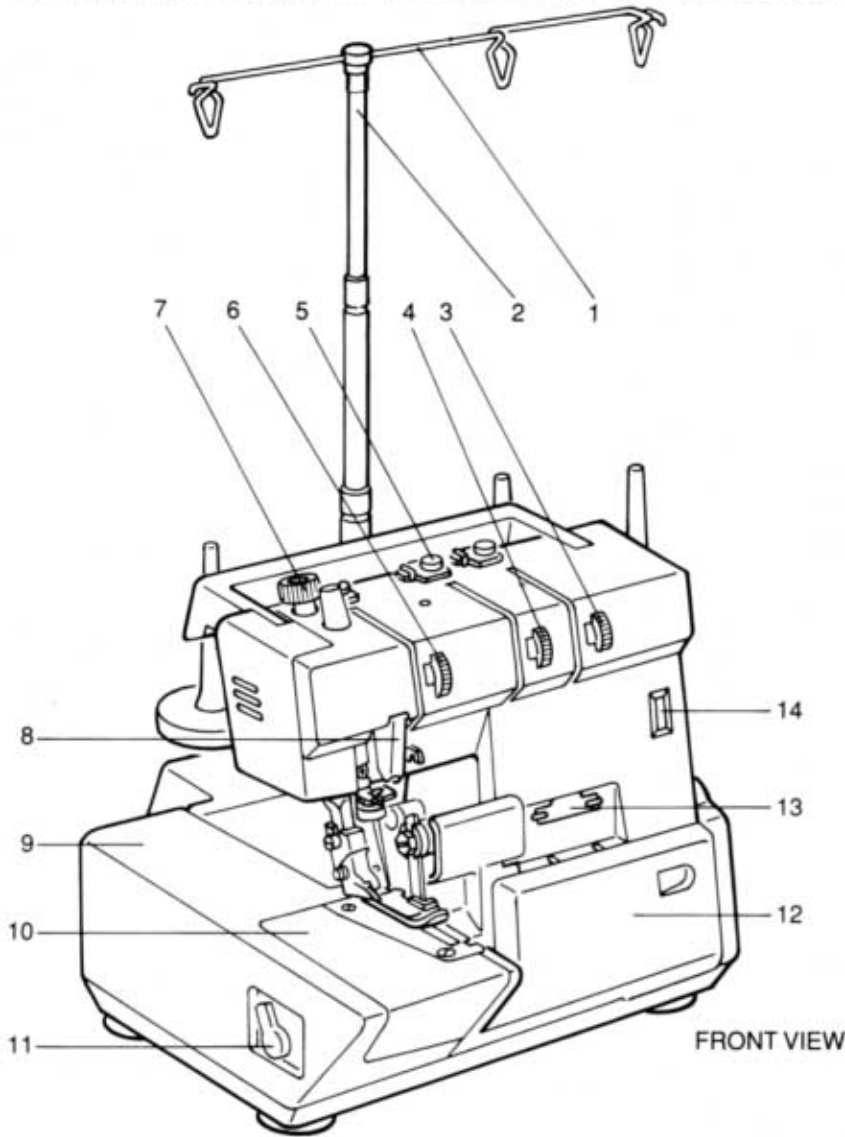

1. Thread Guide Hanger
2. Extension Bar
3. Lower Loper Thread Tension Dial
4. Upper Loper Thread Tension Dial
5. Thread Guide and Tension Disc
6. Needle Thread Tension Dial
7. Pressure Regulator
8. Thread Take-up Lever
9. Extension Table
10. Free Arm
11. Extension Table Lock/Release Lever
12. Front Cover
13. Loper Thread Guide
14. Stitch Length Regulator

FRONT VIEW

15. Stitch Length Regulator Dial
16. Hand Wheel
17. Terminal Box
18. Spool Stand
19. Spool Pin
20. Spool Supporter
21. Presser Foot Lifter
22. Handle

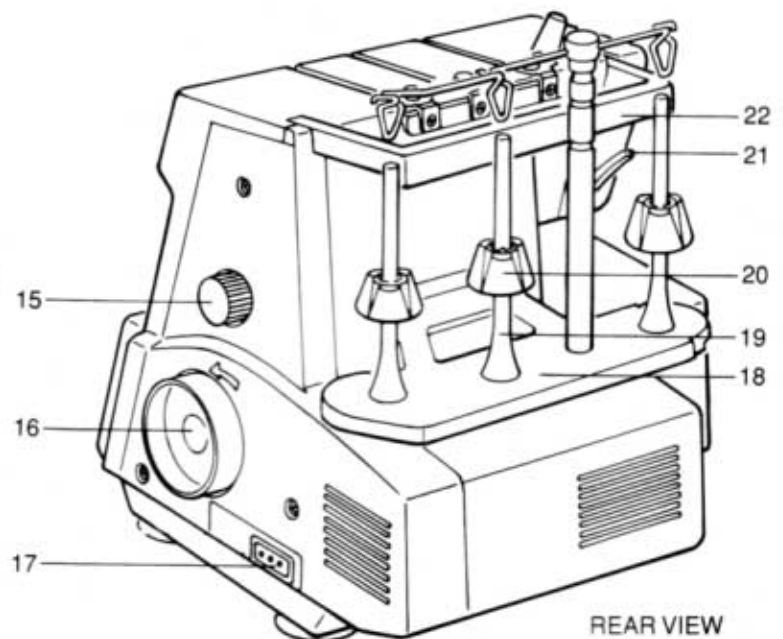

REAR VIEW

INSIDE OF FRONT COVER AND FREE ARM COVER

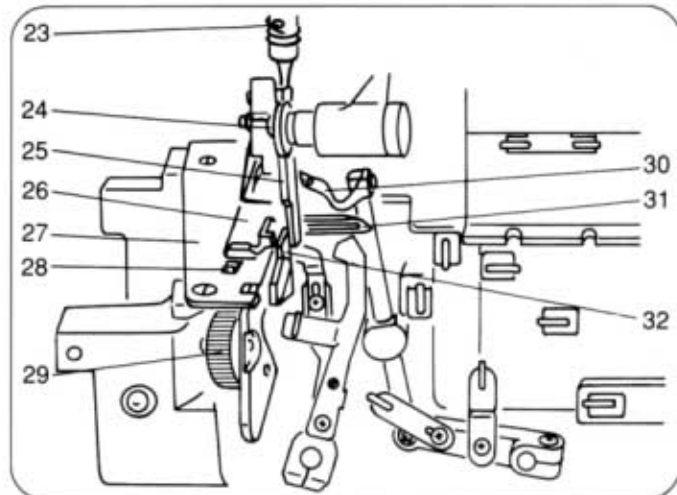

- 23. Needle Bar Thread Guide
- 24. Upper Knife Holder
- 25. Upper Knife
- 26. Presser Foot
- 27. Throat Plate
- 28. Feed Dog
- 29. Seam Width Knob
- 30. Upper Looper
- 31. Lower Looper
- 32. Lower Knife

ACCESS TO THREAD GUIDES AND FREE ARM

1. Place thumb in hollow of front cover and slide it to the right as far as possible; pull cover down toward you.
2. To close, lift cover up and it will snap into place.
3. Be sure that the cover is properly closed before starting to sew.

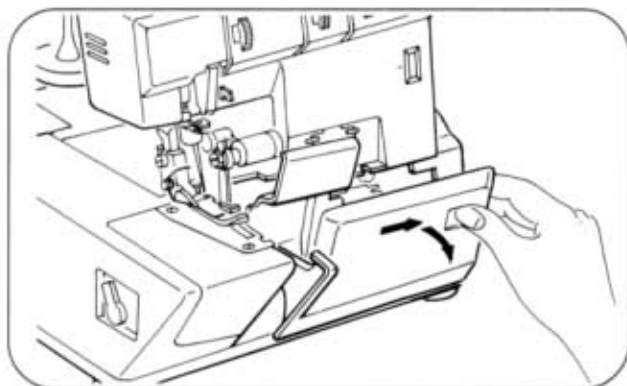

Opening the Extension Table

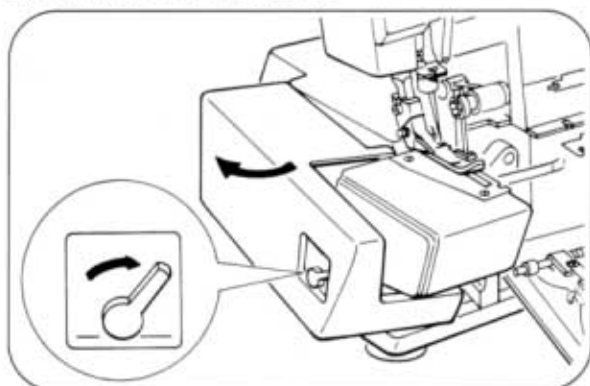

1. Turn lever located on left side of Extension Table toward front of machine.
2. Pull Extension Table out to open.
3. To close shut and trim lever in opposite direction. This locks the Extension Table to Free Arm Cover.

Removing the Free Arm Cover

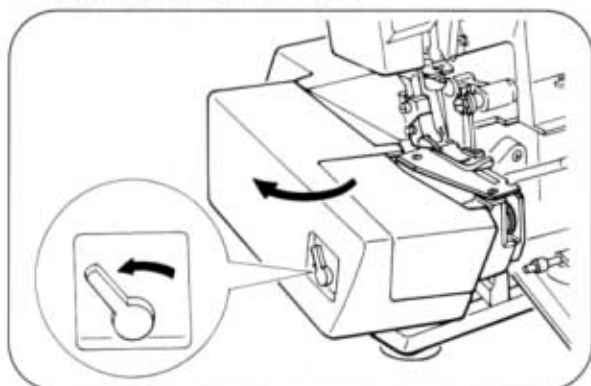

Swing Extension Table out with lever in locked position and Free Arm Cover will stay attached to the Extension Table.

ACCESSORIES

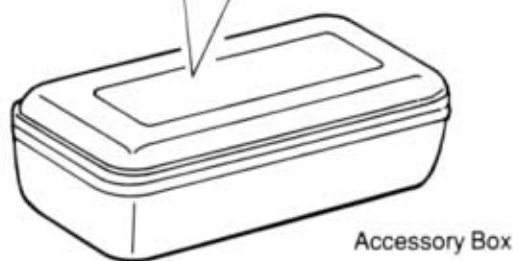
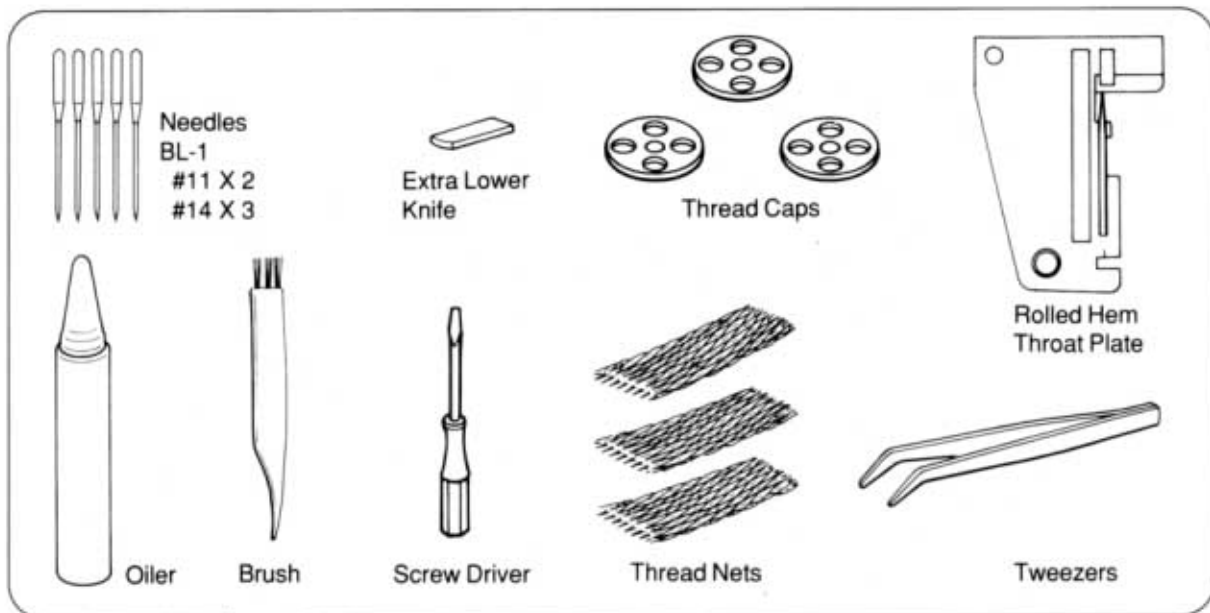

ELECTRICAL CONNECTION

Connect the electrical cord to the machine by inserting the three-hole plug into the terminal box located on the right side of the machine. Connect the cord plug into an electrical outlet.

Place Foot Control on floor where it is easy to reach with your foot.

To make machine go faster, press down on Foot Control; to slow down let up slightly.

CAUTION

1. Disconnect the electrical cord from the wall outlet when machine is not in use or when it is being cleaned.
2. Disconnect the electrical cord from the wall outlet before changing needles or throat plates. This will help prevent accidents.

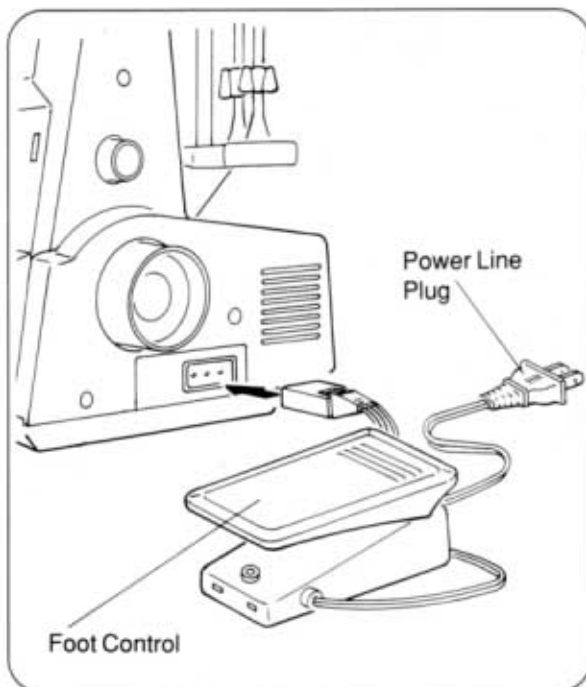

NEEDLE, THREAD AND FABRIC CHART

The chart shows size and type of thread, and needle size for various weights and types of fabrics. Size means the fineness of both needle and thread.

Use BL-1 type needle for this machine. The needle size is located on the shank of the needle.

FABRICS		THREADS	NEEDLE SIZES
LIGHTWEIGHT: organdy, voile, taffeta, lawn, crepe		Cotton #100 Silk #100 Spun #80-100 Tetron #90	#11
MEDIUM WEIGHT: gingham, satin, seersucker, linen, velveteen, gabardine, broadcloth		Cotton #60-80 Silk #50 Spun #60-90 Tetron #60-80	#11, #14
HEAVY WEIGHT: denim, tweed, corduroy, pile fabrics		Cotton #40-60 Silk #40-50 Spun #60-90 Tetron #50-60	#14
KNIT	tricot	Spun #60-80 Tetron #60-80	#11
	jersey	Spun #60-80 Tetron #60	#11, #14
	wool	Spun #60-80 Tetron #50-60 Woolly nylon Woolly tetron	#14

INSERTING THE NEEDLE

Select the proper type and size needle for fabric used.
(See "NEEDLE, THREAD AND FABRIC CHART")

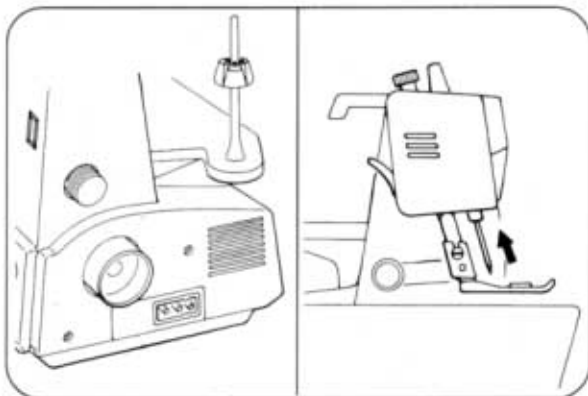

1. Disconnect the electrical cord from the wall outlet.
2. Turn hand wheel toward you until the needle comes to its highest point.

CAUTION:

Use "BL-1" needles for this machine.
Household type needles cannot be used, the
needle may break from the high speed of sewing.

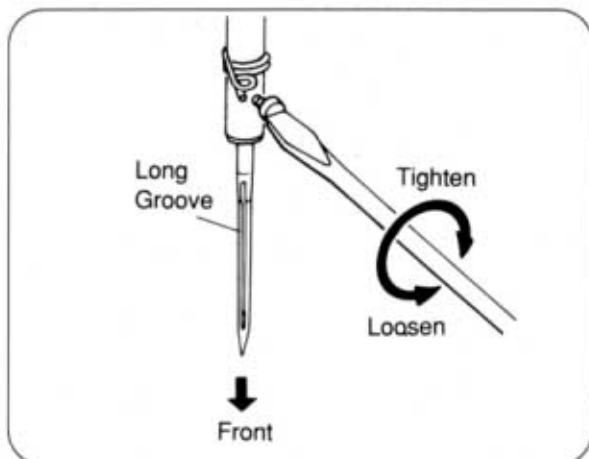

3. Use the screw driver provided in the accessory box to loosen the needle clamp screw, and remove the needle.
4. Insert the needle as far as it will go with the long groove facing front.
5. Retighten the screw.

THREADING THE MACHINE

When threading, be sure to follow the directions given below. The machine will not sew properly if threaded incorrectly. An illustration for correct threading is given inside the front cover of the machine. The thread guides are identified with color markings corresponding to the thread to which they belong.

Thread the machine in the following sequence: Upper Looper (threading points marked in green), Lower Looper (threading points marked in blue), needle (threading points marked in yellow).

extension bar

1. Pull the Extension Bar up as far as it will go.
2. Rotate the Thread Guide Hanger so that the Thread Guides are right above the spool pins.
3. Place the spools or thread cones on spool pins.

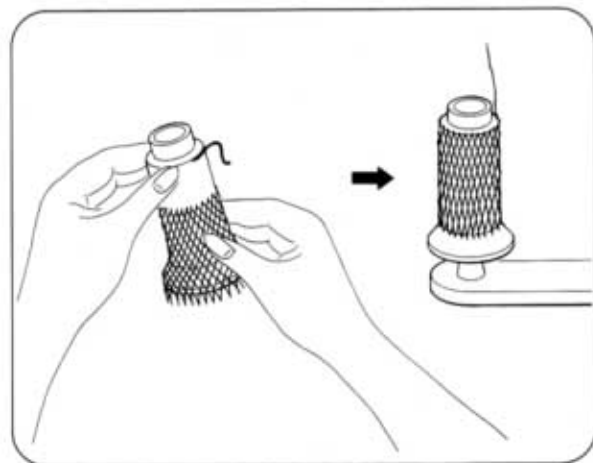
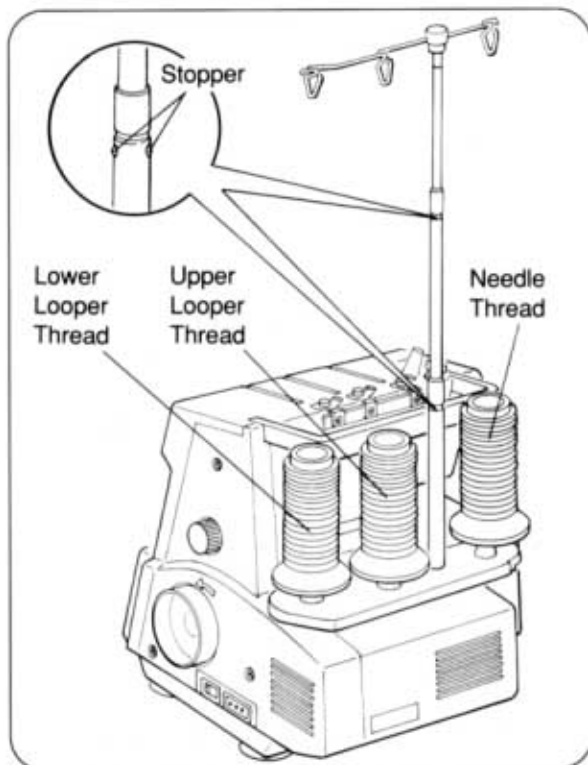

Thread spool nets are useful for synthetic threads which tend to come loose and slip out. Cover the thread cones with the thread nets provided in the accessory box. Bring thread end to the top of the cone.

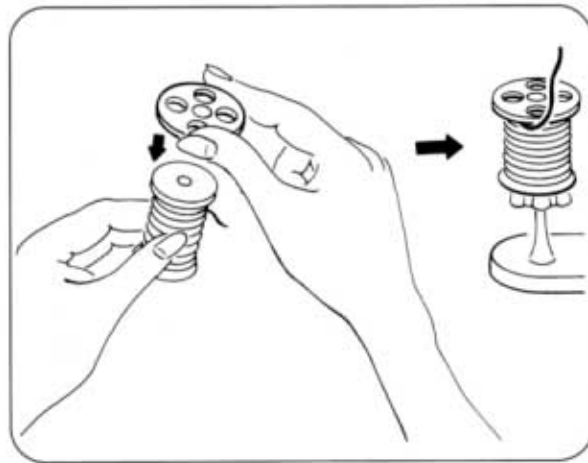

Thread caps are also provided with the accessories. They are used when sewing with regular spools. Insert the stem of cap into the spool hole.

threading the upper looper

Open the front cover and thread upper looper thread as illustrated below 1 to 10.
Follow thread guides with green color markings on machine.

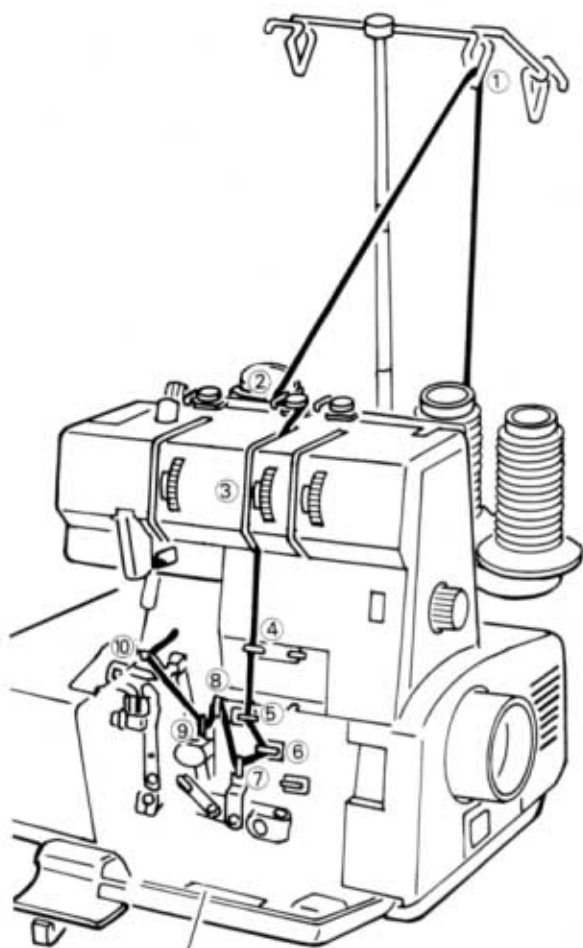

Threading Chart

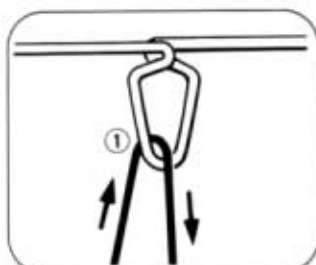

1. Pass thread through top guide from back to front.

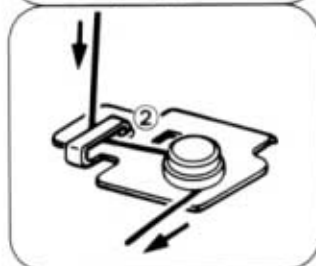

2. Bring thread down and pass through thread guide and under Tension Disc.

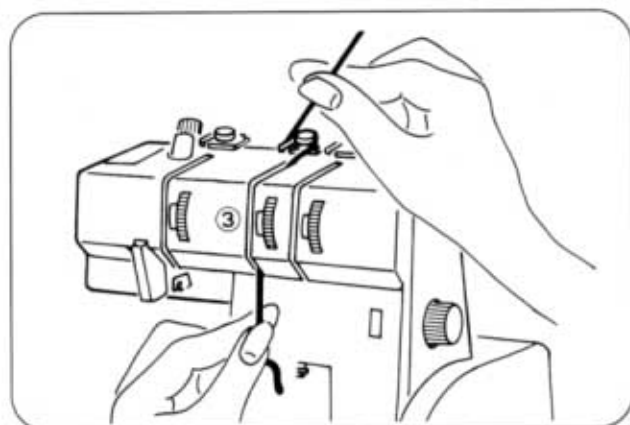

3. Bring thread straight down through the slot so that it passes between the tension discs.

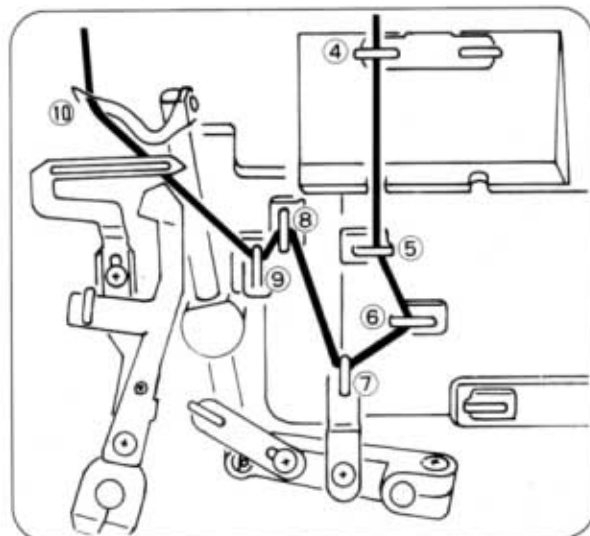

4. Hook thread into guide from the right side.
5. Hook thread from the left side.
6. Hook thread from the right side.
7. Hook thread from the bottom side and pull thread up.
8. Hook thread from the top side.
9. Hook thread from the bottom side and pull thread up.
10. Use tweezers to pass thread through the upper looper hole front to back. Pull at least 7 cm (3 inches) of thread through the upper looper.

threading the lower looper

Remove the free arm cover and thread lower looper thread as illustrated below A to I (Thread guides with blue color marking on machine).

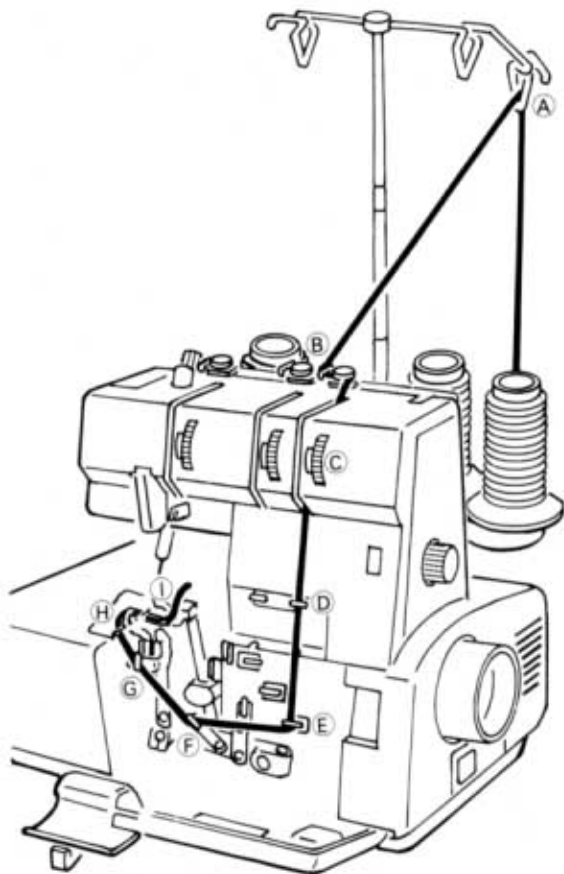

- A. Pass thread through guide from back to front.
- B. Bring thread down and pass through thread guide and under tension disc.



- C. Bring thread straight down along the slot so that the thread passes between the tension discs.

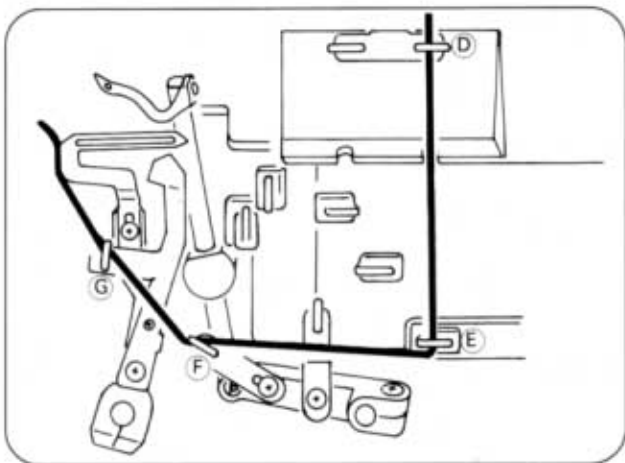

- D. Hook thread into guide from the left side.
- E. Hook thread from the right side and pull thread toward left.
- F. Hook thread from the bottom side.
- G. Hook thread from the bottom side and pull thread toward left.

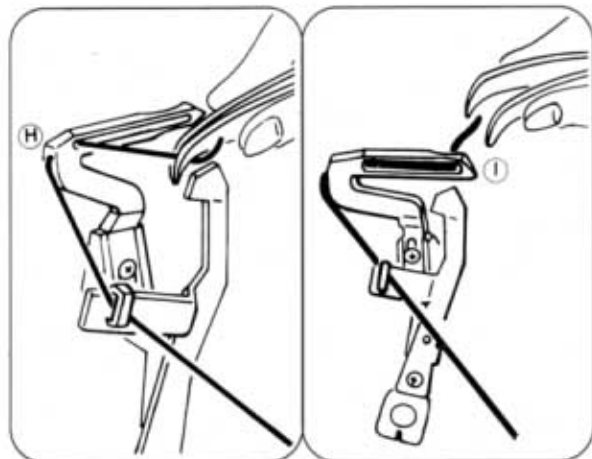

- H. Turn hand wheel toward you until the lower looper is in extreme left position. Pass thread through hole using the tweezers.
- I. Turn hand wheel until the lower looper is in extreme right position. Use the tweezers to pass thread through hole front to back. Pull at least 7 cm (3 inches) of thread through lower looper.

threading the needle

Thread needle thread as illustrated below a to h (Thread guides with yellow color marking on machine).

- a. Pass thread through guide from back to front.
- b. Bring thread down and pass through thread guide and under Tension Disc.

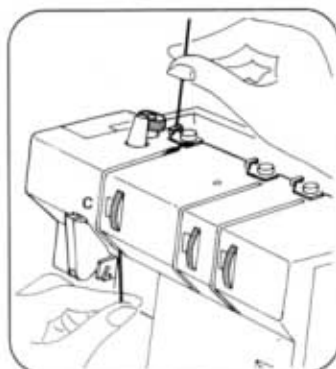
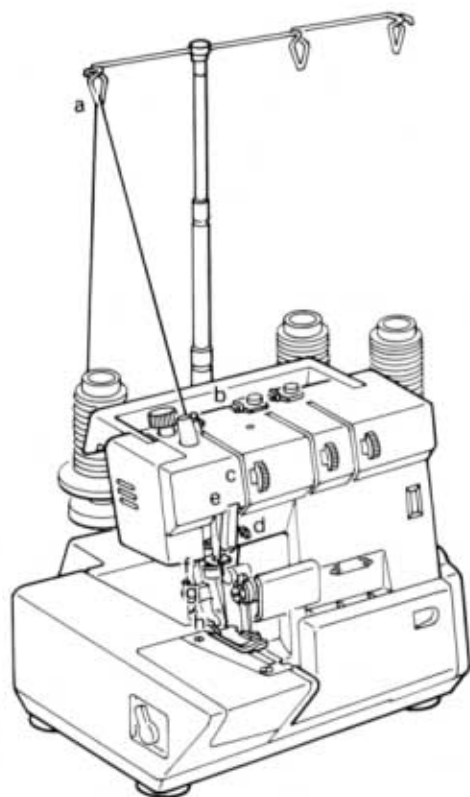

- c. Bring thread straight down along the slot so that the thread passes between the Tension Discs.

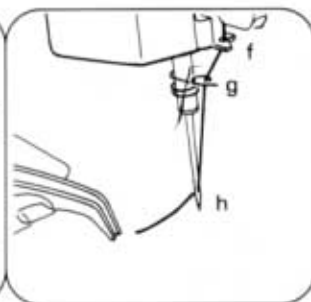

- d. Hook thread into guide from right to left and pull thread up.
- e. Place into guide by sliding thread across top and down into cutout.
- f. Hook thread into guide from the opening on right side of guide.
- g. Pass thread through guide.
- h. Use the tweezers to pass thread through the needle eye front to back.

easy thread changing

Instructions for changing threads are given below.

1. Cut the thread near the spools.
2. Exchange the spool with a new one and tie end to remaining thread making knot as small as possible.
3. Note the numbers on each Thread Tension Dial.
4. Turn Thread Tension Dials to the smallest number.
5. Press Foot Control and run machine until upper and lower thread knot comes through looper hole.
6. Stop needle thread knot before passing through eye of needle. Pull needle thread near the needle eye and cut thread knot.
7. Pass thread through needle eye manually.
8. Return tension dials to noted number.

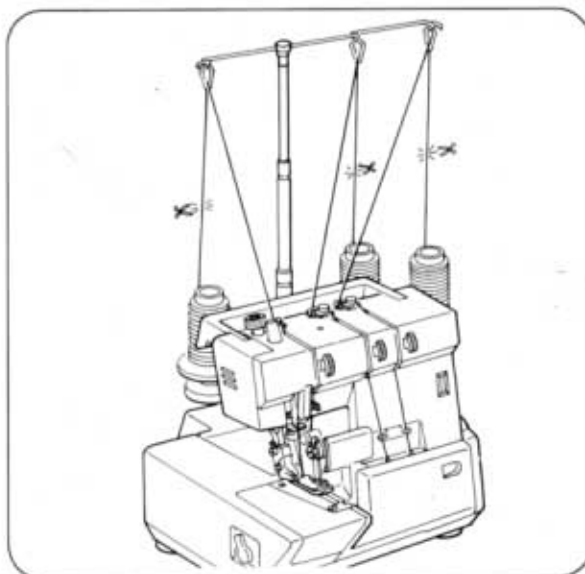

BEFORE STARTING TO SEW

When the machine is plugged in properly and threaded correctly it is ready for sewing. To insure good stitches, make several sewing tests using the same fabric and thread on which you will sew. Make the proper adjustments while test sewing.

starting to sew

1. Pull 3 threads under the presser foot and toward the back. Check that the threads near loopers and needle should not be caught by incorrect part.
2. Lower the presser foot.
3. Turn hand wheel toward you 2 or 3 times and check the thread chain.
4. Press Foot Control lightly pulling threads toward back and make thread chain about 5 cm (2 inches).
5. Place a scrap of fabric under the toe of the presser foot at the position to be stitched.
6. Hold end of thread with your left hand and pull gently when starting to sew.
7. When you have started sewing, place hand lightly on fabric. Start machine slowly and gradually increase the sewing speed.

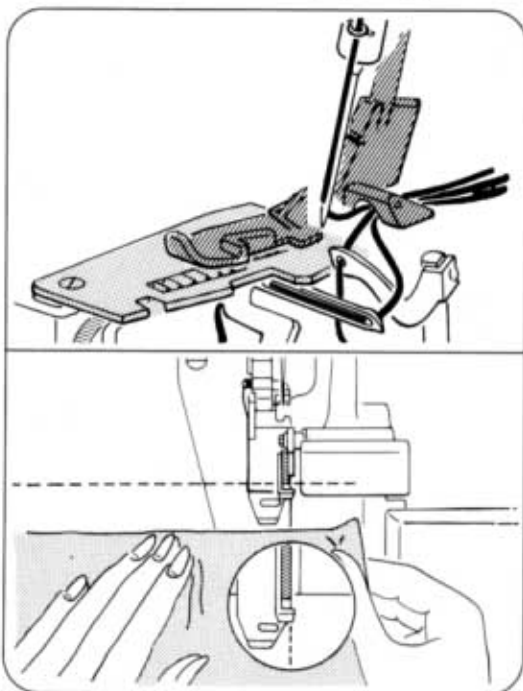

end of seam

1. When the needle reaches the end of seam, chain off by running the machine until the thread chain is 6-7 cm (2-3 inches) long.
2. Stop the machine and cut the thread chain remaining 3-4 cm (1-2 inches) to the machine. Tie small knots in thread ends and treat with dot of seam sealant. Let dry and trim close to knot.
3. For neater finish, pull thread ends back through seam using hook or yarn needle.

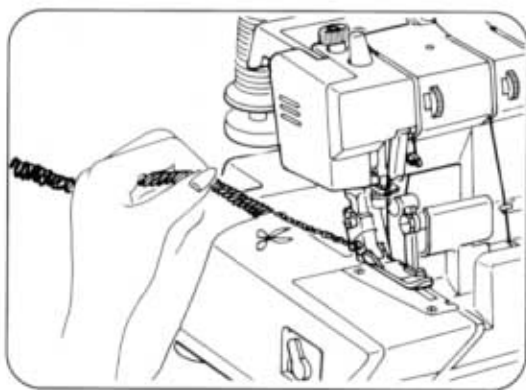

when thread breaks

If the thread breaks while sewing, remove fabric from machine and rethread as indicated below.

- Upper Looper Thread; turn hand wheel toward you until the upper looper is in the lowest position. Pass thread through the looper hole.
- Lower Looper Thread; cut the needle threads near needle hole and rethread the lower looper thread through its looper hole.
- Needle Thread; rethread needle thread as indicated on page 9.

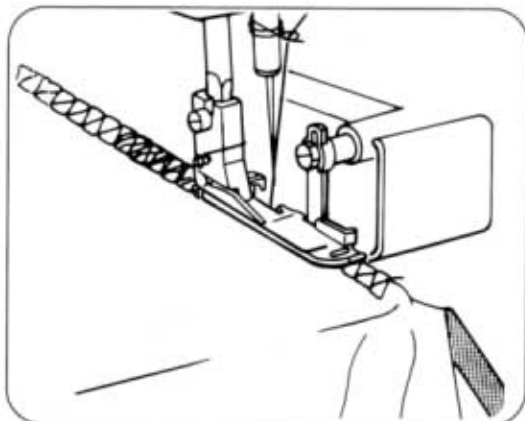

To begin sewing, place material 3-4 cm (1-2 inches) behind point where thread broke.

OVERLOCK SEWING

This machine will sew overlock stitches and simultaneously trim the fabric.

The machine is delivered from the factory preset. You may wish to make some adjustments to better suit individual fabrics.

REGULATING THE THREAD TENSION

Quality stitches depend on proper balance between the three thread tensions. The tension may need adjusting depending on the type of fabric, heaviness of fabric and size of thread used.

The table below is a guide for adjusting the thread tension.

Note: Be sure that the thread is passing between the tension discs.

Fabric	Needle Thread	Upper Looper Thread	Lower Looper Thread
Light Weight	1.5-3.5	2.5-4.5	2.5-4.5
Medium Weight	2-4	3-5	2.5-4.5
Heavy Weight	2-4	2-5	2-4

NOTE:
This table is a guide for thread tensions when sewing with #80 to #90 polyester spun threads.

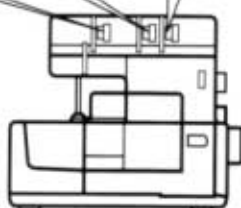

The charts below are illustrations of stitches needing adjustment in the thread tension.

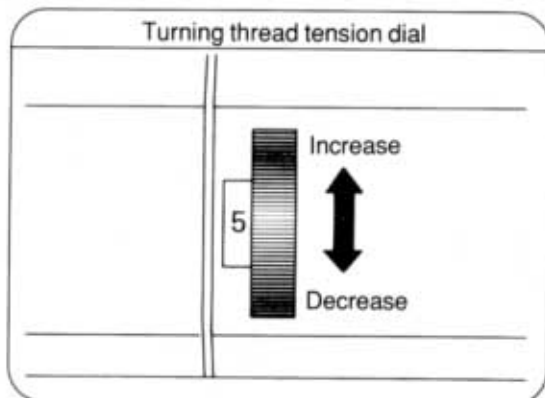
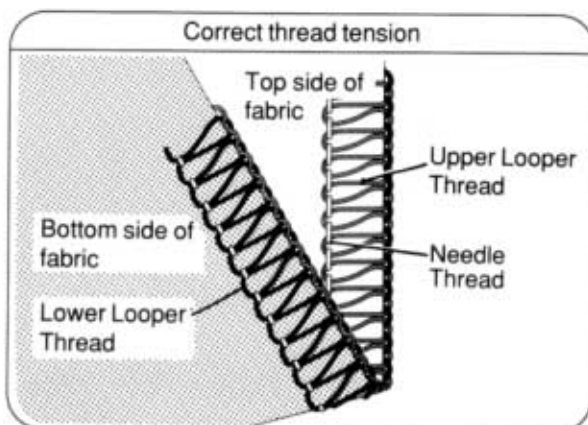

TO INCREASE, turn tension dial to a higher number.

TO DECREASE, turn tension dial to a lower number.

Needle thread is too loose. (Clearly visible on the bottom side of fabric.)			Upper looper thread crossed on bottom side of fabric.			Lower looper thread crossed on top side of fabric.		
Needle Thread	Upper Looper Thread	Lower Looper Thread	Needle Thread	Upper Looper Thread	Lower Looper Thread	Needle Thread	Upper Looper Thread	Lower Looper Thread
Increase	—	—	—	Increase	—	—	—	Increase
—	Decrease	Decrease	—	—	Decrease	—	Decrease	—

SETTING STITCH LENGTH

The stitch length can be adjusted between 1 and 5 mm.

As a rule, light weight fabrics take a shorter stitch. Heavy weight fabrics need longer stitches.

Most normal sewing is done with stitch length dial set at 3. This produces a medium length stitch which makes a strong seam and is suitable for most fabrics.

For shortest stitch, turn dial to 1.
For longest stitch, turn dial to 5.

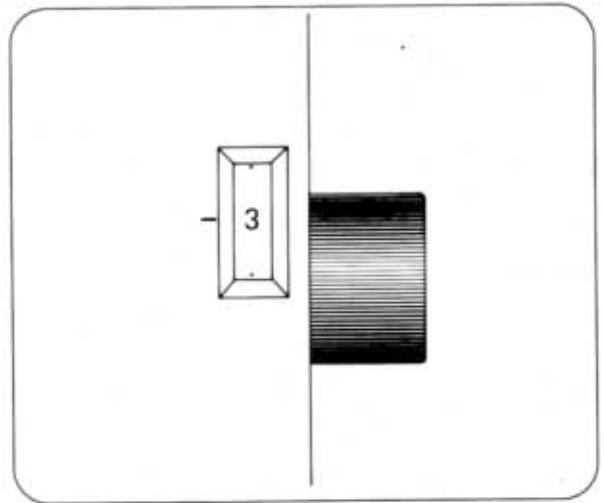

SETTING SEAM WIDTH

This overedge seam width can be adjusted to sew a 3.5 mm (about 1/8") to 5 mm (about 1/6") stitch. The machine is set at 3.5 mm which is the width used most often for overlock sewing. For heavy weight fabrics, set control knob to wider stitch.

1. Disconnect the electrical cord from the wall outlet.
2. Open front cover and Free Arm Cover.
3. Push the Upper Knife Holder to the right and turn the Seam Width Knob downward to select wider stitch width. For smaller width turn knob in opposite direction.

When adjusting the width, use graduations on throat plate as guide and line up with left edge of lower knife holder.

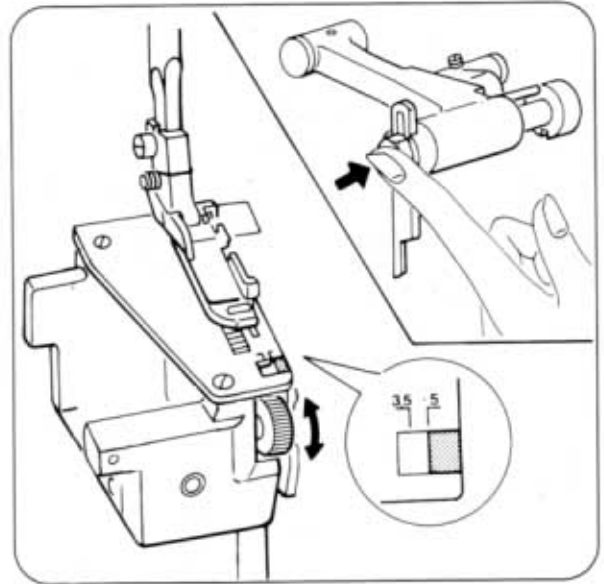

ADJUSTING THE PRESSURE ON FABRIC

The pressure on the foot can be adjusted for different weight fabrics.

The fabric should move along smoothly and evenly without slipping.

Stitches should be uniform in size.

The pressure on this machine is set for sewing medium weight fabrics.

For sewing light weight fabrics, decrease the pressure (turn screw to left).

For heavy weight fabrics, increase the pressure (turn screw to right).

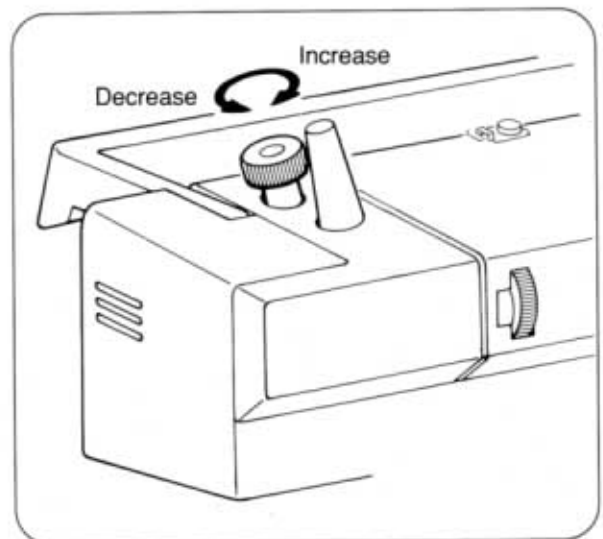

NARROW AND ROLLED HEMMING

The machine trims fabric, folds back the edge and sews a narrow hem (overedge). The width of the narrow overedge is 1.5 mm (about 1/16") and is used for overedging light and medium weight fabrics.

Two variations of the rolled overedge hem can be sewn with this machine by changing the thread tension. Both methods are used with light and medium weight fabrics.

Method B (page 15) gives a softer finish by pulling the interlocking threads to the wrong side.

changing the throat plate

The machine comes with a standard overedge throat plate set to the machine. Change the throat plate when sewing rolled overedges.

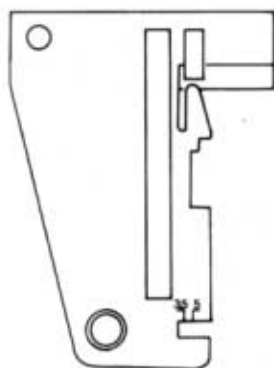

Standard Overedge
Throat Plate

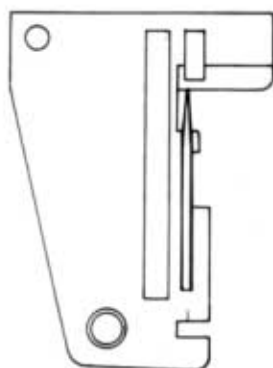

Rolled Hem
Throat Plate

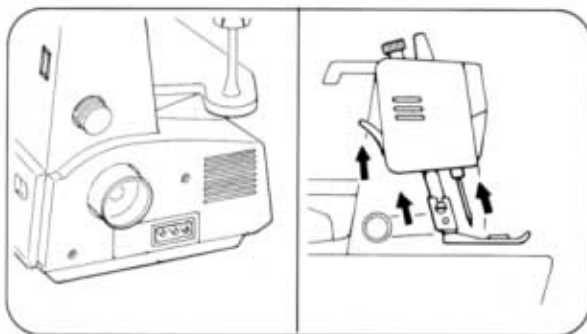

1. Disconnect the electrical cord from the wall outlet.
2. Turn hand wheel toward you until needle is at its highest point.
3. Lift presser foot bar.

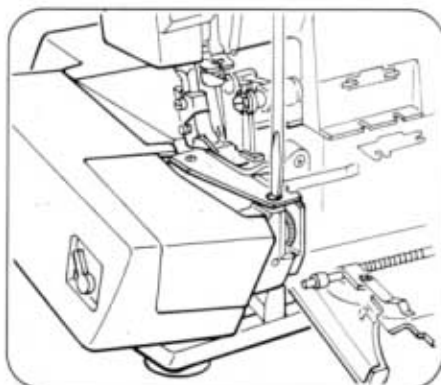

4. Open Extension Table and Free Arm Cover (See page 3).
5. Loosen the front side screw.



6. Lift the Throat Plate off and replace with Rolled Hemming Plate. (Be sure that thread is not caught under plate.)

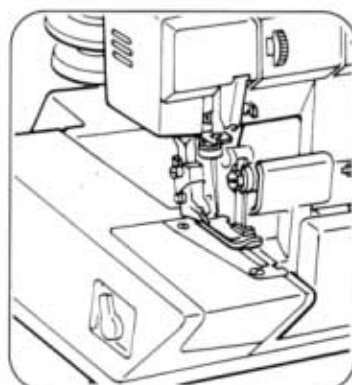

7. Retighten the screw and replace Free Arm Cover.

setting controls

Set the controls as follows.

1. Fabric, Thread & Needle

Refer to Page 5 "NEEDLE, THREAD & FABRIC CHART", for selecting suitable thread and needle sizes for sewing on light and medium weight fabrics.

2. Stitch Length Regulator

Set stitch length between 1 and 2 mm.

3. Seam Width Knob

The seam width for sewing rolled overedge is normally 1.5 mm (about 1/16").

Turn seam width knob and adjust so that the left side of Lower Knife Holder is aligned with the mark of the Rolled Hem Throat Plate. (See page 12.)

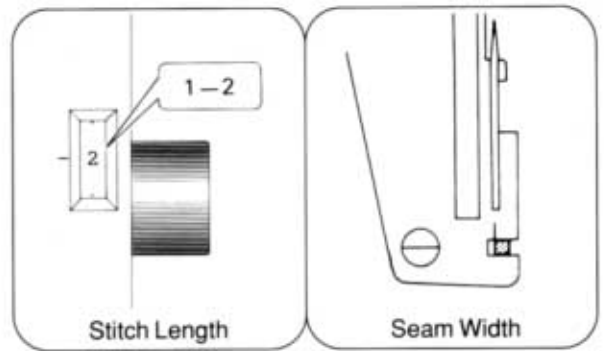

sewing

Pull the excess threads gently toward the back and begin sewing.

Pull fabric lightly in the direction it is being fed.

Although the stitch width is set at 1.5 mm, you will actually need 3.5 mm (about 1/8") to provide enough fabric for the fold back.

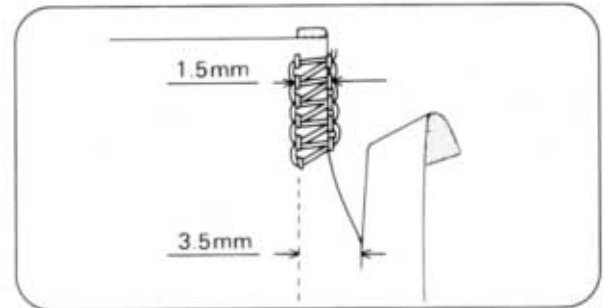

thread tension -Method A

Use the chart to the right as a guide in setting tension.

The tension adjustments for Method A are the same as overlock stitching except for the fabric edge is rolled to wrong side. See page 11 if adjustments are needed.

Fabric	Needle Thread	Upper Looper Thread	Lower Looper Thread
Light and Medium	1.5-3.5	2.5-5	2-4

NOTE:

This table is a guide for thread tensions when sewing with #80 to #90 polyester spun threads.

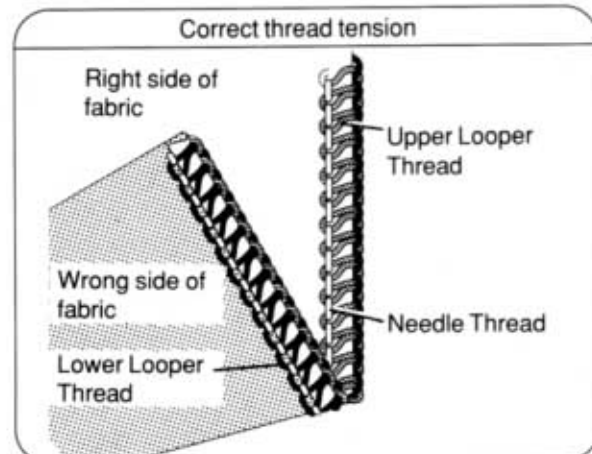
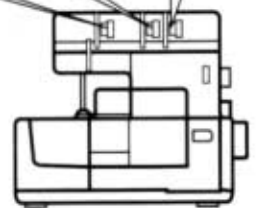

ROLLED OVEREDGE

The upper looper thread sews through to the wrong side of fabric in Method B rolled overedge hem creating a softer finish.

1. Change the Standard Overedge Throat Plate to the Rolled Hem Throat Plate.
2. Settings and sewing of Method B rolled overedge hem are the same as the Method A rolled overedge except for thread tension. (See Below)

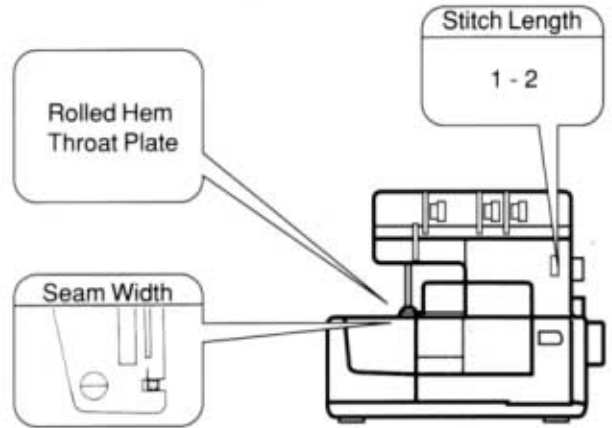

thread tension -Method B

Regulate the tension dials using guide below.

Fabric	Needle Thread	Upper Looper Thread	Lower Looper Thread
Light and Medium	1.5-3.5	2.5-5	4-6

NOTE:
This table is a guide for thread tensions when sewing with #80 to #90 polyester spun threads.

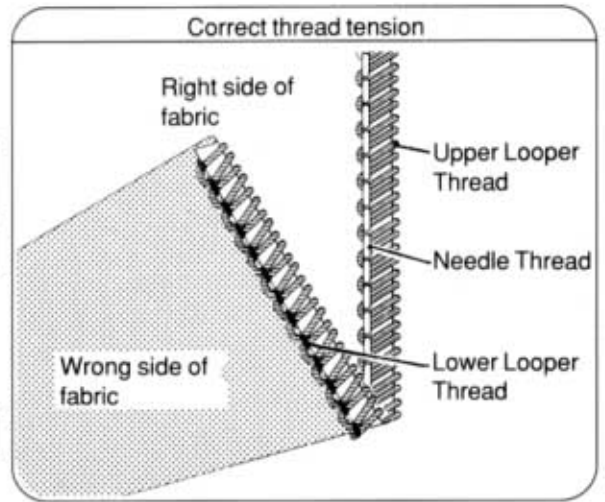
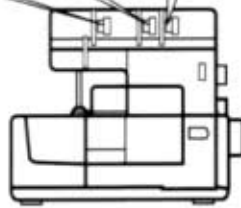

Needle thread is too loose.			Upper looper thread is too loose.			Lower looper thread is too loose.		
Needle Thread	Upper Looper Thread	Lower Looper Thread	Needle Thread	Upper Looper Thread	Lower Looper Thread	Needle Thread	Upper Looper Thread	Lower Looper Thread
Increase	—	—	—	Increase	—	—	—	Increase
—	Decrease	—	—	—	—	—	Decrease	—

TURNING CORNERS

outside corner

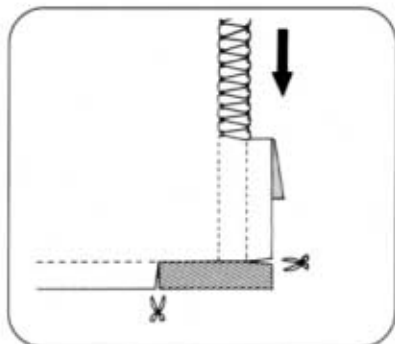

1. Cut the corner about 5-6 cm (2-3 inches) along the cutting line.

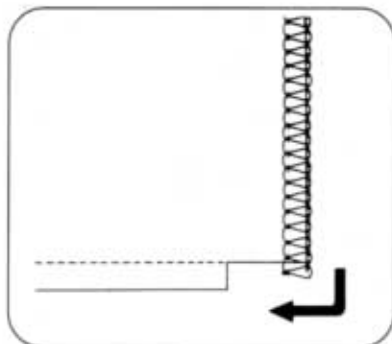

2. Sew a few extra stitches past end of fabric and stop machine.
3. Raise needle and presser foot.
4. Pull fabric slightly toward the back and pull out tangled thread from Throat Plate.

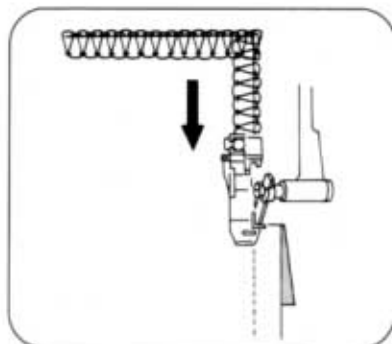

5. Turn fabric and position the fabric by lining up the cut line and knife. Lower the Presser Foot.
6. Resume sewing.

inside angle and slits

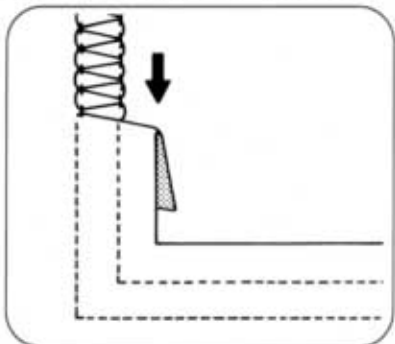

1. Sew desired seam line until you approach the corner.

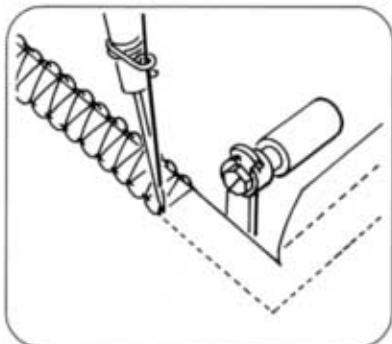

2. When you approach the corner, slow down and allow the knife to make one more small notch into the corner.

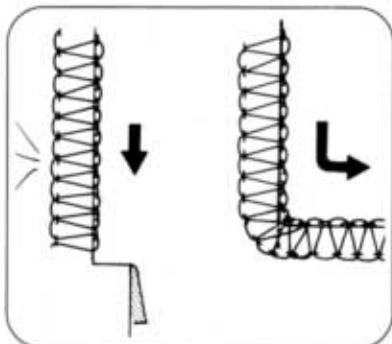

3. Straighten the fabric out in front of the knife and stitch completing the edge.

outside curves

The machine can continue sewing when rounding a curve. There is no need to stop the machine and pivot. Push excess fabric toward the presser foot giving the machine more fabric and continue sewing as if sewing a straight seam.

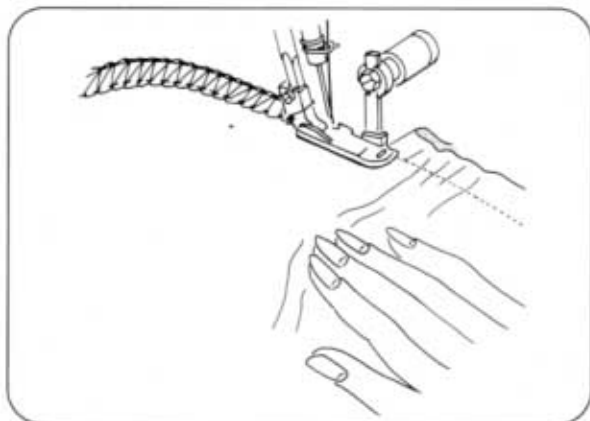

FREE ARM SEWING

This machine will convert to free arm sewing by simply opening the Extension Table. It is used for sewing sleeves, trousers or similar places that are difficult to sew on a flat bed machine.

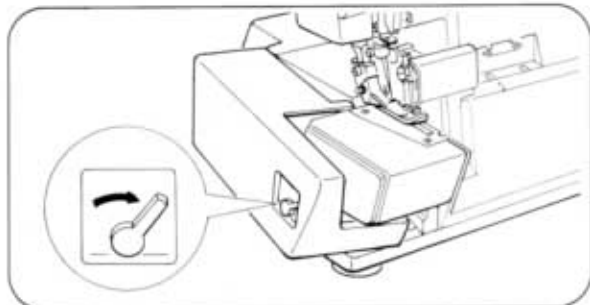

Turn lever located on left side of extension table to the front of machine and swing table out.

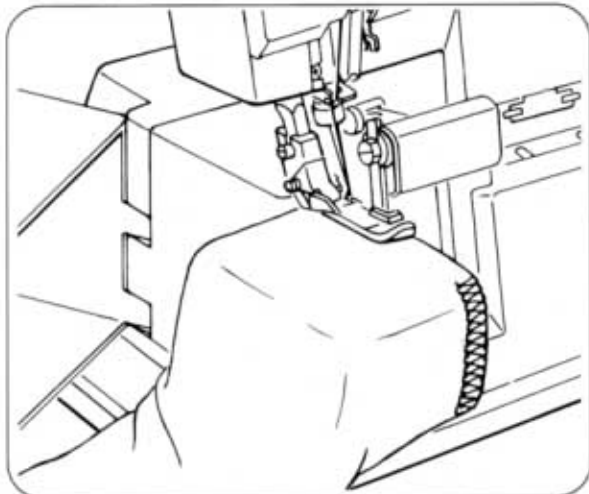

DECORATIVE OVERLOCK

When you change the Upper Looper Thread to heavier thread or yarn, you can produce decorative overlock stitching.

Try using various types of thread to create attractive combinations experiment with different tension adjustments to produce a variety of decorative effects.

Examples;

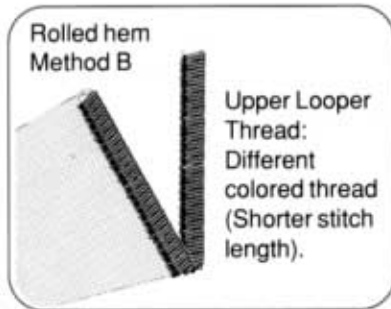
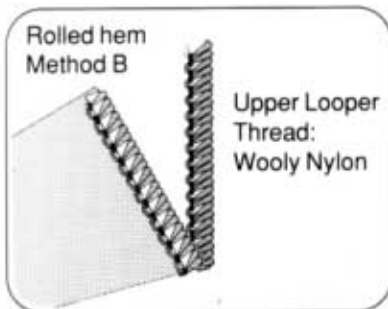
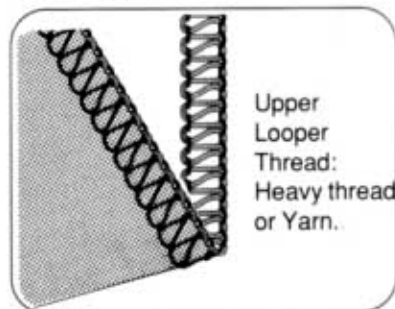

CLEANING AND MAINTENANCE

cleaning

Fabric, thread scraps and dust may accumulate around moving parts and effect the functioning of machine. Unplug cord and clean machine with the brush provided in the accessory box.

Brush around the fabric feed dog

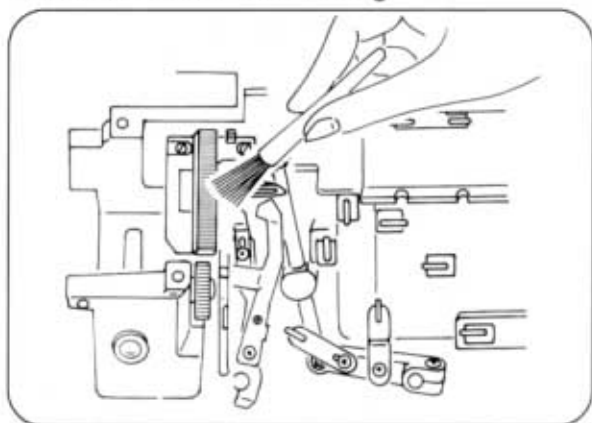

Brush inside of the front cover

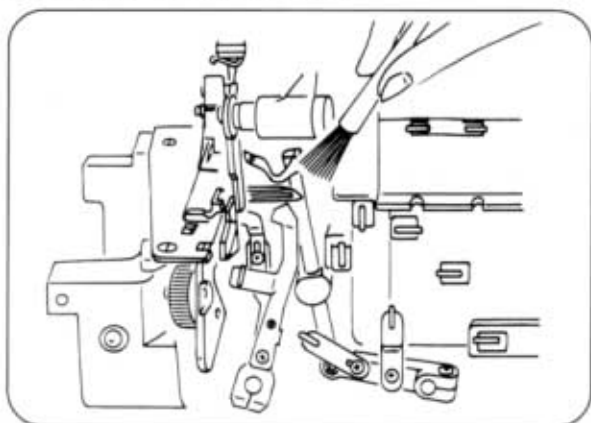

oiling

Critical parts used in this machine are made of special material that does not require oiling. Only the parts indicated with arrows shown below needs oiling. Depending on use these should be oiled once or twice a month.

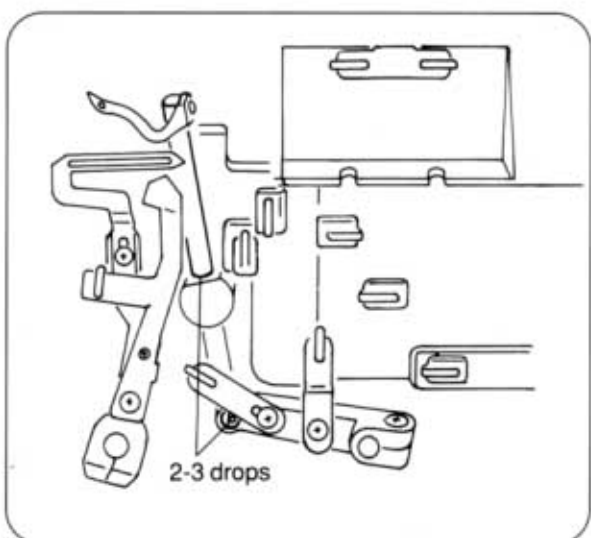
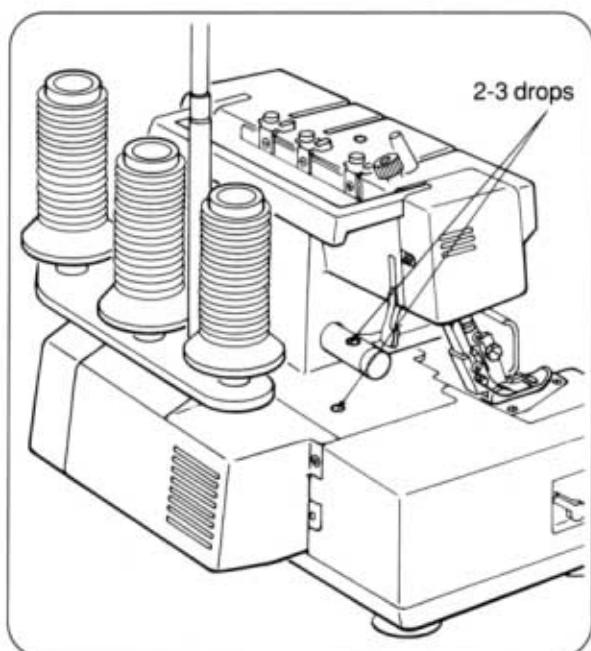

changing the lower knife

Exchange the Lower Knife as shown below when it becomes dull. An extra knife is provided in the Accessory Box.

1. Unplug the machine.
2. Open the front cover.
3. Raise the upper knife as illustrated below.

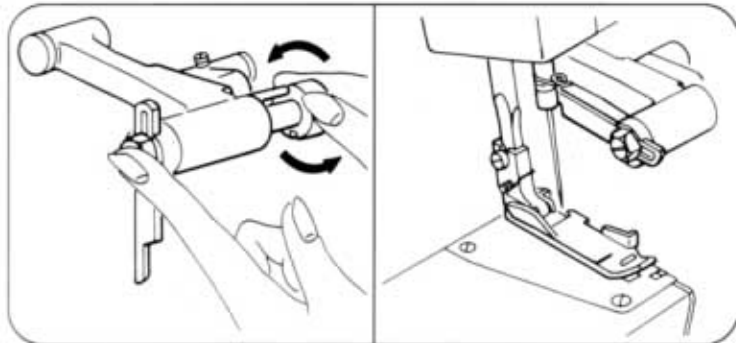
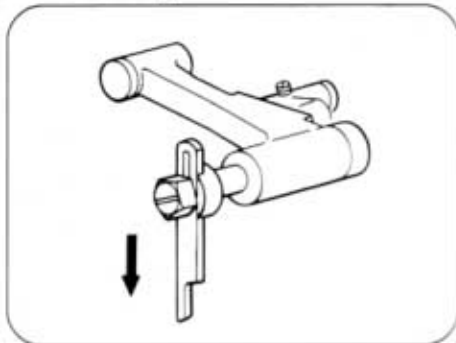

- a. Turn hand wheel towards you until the upper knife is at its lowest point.
 - b. Push the upper knife holder to the right as far as it will go and turn knob in opposite direction until it clicks into position.
4. Loosen the Lower Knife Screw and take out the knife.
 5. Install new knife by inserting it into the groove of the knife holder. Be sure that the tip of the lower knife is lined up with the surface of Throat Plate, and tighten screw.
 6. Return the Upper Knife to cutting position by pushing knife holder to right and turning knife toward you until it clicks into position. Close the front cover.

The upper knife is made of special hard material and should not require replacement under normal use. If it should chip or need replacement, call for your dealer.

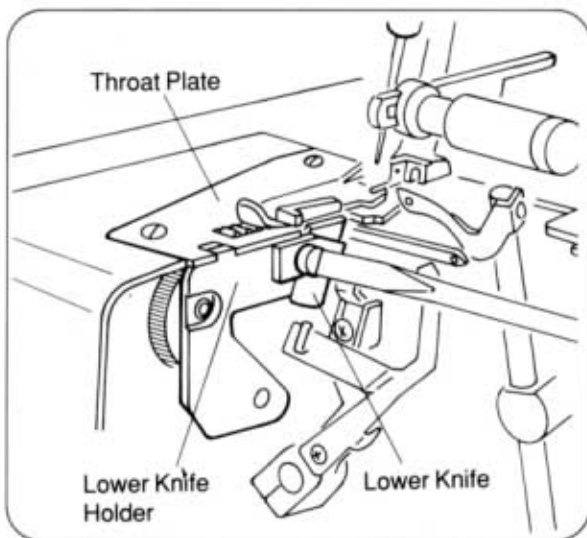

changing the sewing light

If the sewing light does not light when power switch is turned on, replace the bulb.

1. Unplug sewing machine from the wall receptacle.
2. Remove the Light Cover by loosening the screw.
3. Remove the bulb.
4. Replace with new bulb of same size wattage and size.
5. Replace the Light Cover.

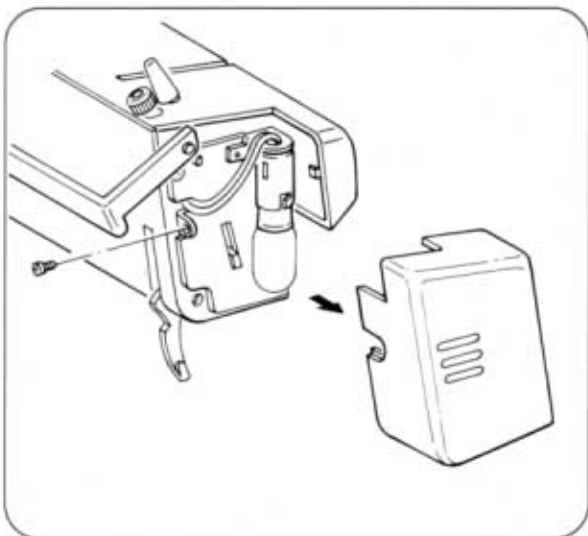

BEFORE YOU CALL FOR SERVICE

Your new overlock sewing machine was carefully inspected and tested at the factory and was in perfect working order when shipped.

Under normal conditions, if you carefully follow instructions for threading, operating and maintenance, your machine will give you years of trouble-free service.

Occasional difficulties are usually caused by a condition that can be easily remedied with a minor adjustment. Some possible problems, their causes and corrections are given here.

PROBLEM	CAUSE	CORRECTION	REF. PAGE
THREAD BREAKS	<ul style="list-style-type: none"> •Needle inserted incorrectly •Thread tensions are too tight •Bent or blunt needle •Machine not properly threaded •Threads are caught in incorrect guide 	Reset needle Loosen thread tensions Insert new needle Rethread machine Rethread machine	5 11, 14, 15 5 6-9 6-9
MACHINE SKIPS STITCHES	<ul style="list-style-type: none"> •Bent or blunt needle •Needle inserted incorrectly •Pressure on foot insufficient •Incorrect needle size or type •Machine incorrectly threaded •Tensions set too high 	Insert new needle Reset needle Increase pressure Insert correct needle Rethread machine Loosen thread tensions	5 5 12 5 6-9 11, 14, 15
NEEDLE BREAKS	<ul style="list-style-type: none"> •Pulling fabric while sewing •Incorrect size needle or thread for fabric being sewn •Needle inserted incorrectly 	Do not pull fabric Choose correct needle and thread Reset needle	10 5 5
MACHINE DOES NOT FEED PROPERLY	<ul style="list-style-type: none"> •Pressure on presser foot insufficient 	Increase pressure	12
FABRIC PUCKERS	<ul style="list-style-type: none"> •Lower knife is dull •Stitch length not suitable for fabric •Thread tensions are too tight •Seam width not suitable for fabric 	Change lower knife Readjust stitch length Loosen thread tensions Readjust seam width	19 12 11, 14, 15 12
LOOSE STITCHES OR LOOPS FORMED	<ul style="list-style-type: none"> •Tensions not adjusted properly 	Check thread tensions	11, 14, 15
MACHINE RUNS HEAVILY	<ul style="list-style-type: none"> •Dirt or lint in stitching mechanism 	Clean the machine	18
MACHINE WILL NOT SEW	<ul style="list-style-type: none"> •Cord not plugged into electrical outlet 	Check plug	4