

POLE ASSEMBLY PARTS

Main Tent Poles (2)
 Part No. 9805-1101

Rainfly
 Part No. 9805-1151

1 Layout & Positioning of Tent, Pole Assembly

- Layout and position tent with door facing desired direction. (illus. 1)
- For best results in windy conditions, position door or back of tent into the wind.
- Unzip door.
- Stake down tent corners. Keep the floor taut. (illus. 2)
- Assemble Frame Poles by interlocking the shock-corded sections. This will make two long poles.
- Lay the poles out diagonally, centered on the tent. The center of the poles should cross forming an "X" in the middle of tent. (illus. 1)
- Fasten Toggle & Loop on top of tent over both poles. (illus. 1), (illus. 3)

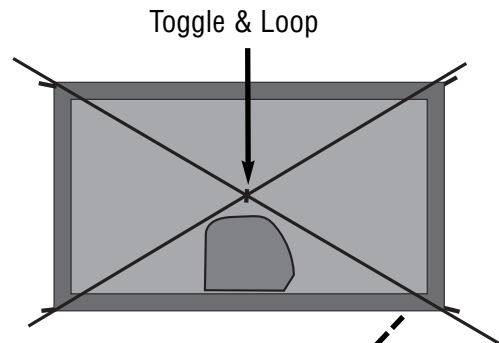

illus. 1

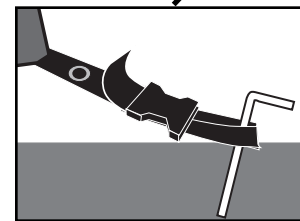

illus. 2
 Tent stake through Loop

2 Connect Frame to Tent

- Insert one Pole Tip into the grommet on the webbing located at the corners of the tent (illus. 4).
- Go to opposite end of the same pole and gradually apply pressure to the pole, forming an arch, until you are able to insert the pole tip into the grommet
- Attach the two Frame Clips at the mesh vent to the pole
- Repeat for second pole

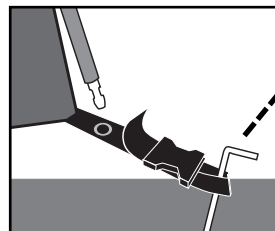

illus. 4
 Insert Pole Tip on stake loop into pole.

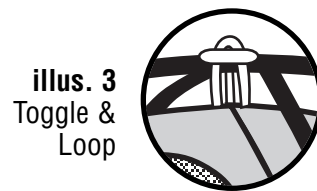

illus. 3
 Toggle & Loop



illus. 6
 Frame Clips

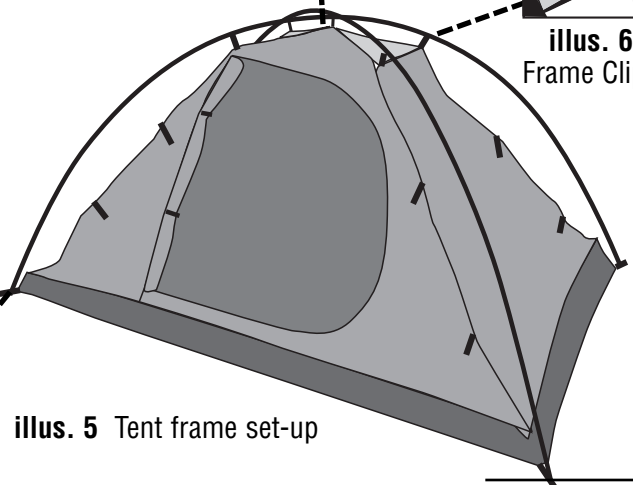

illus. 5 Tent frame set-up

3 Attach Tent to Frame Using Frame Clips

- Attach remaining frame clips along the edges of tent to frame poles (illus. 7), (illus. 8)
- Make any adjustments to the tent corner stakes that are needed.

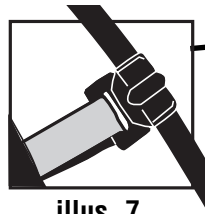

illus. 7
Frame Clips

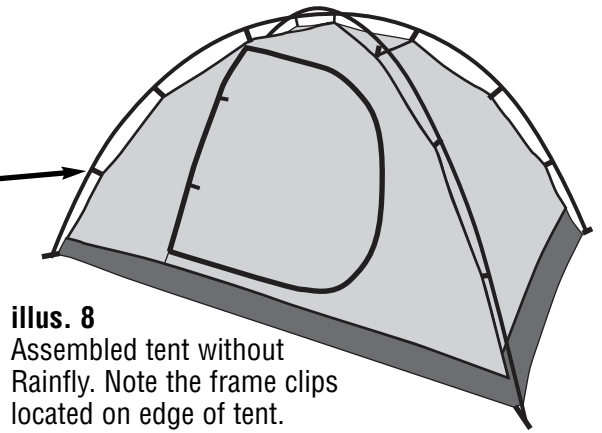

illus. 8
Assembled tent without Rainfly. Note the frame clips located on edge of tent.

4 Attach Rainfly

- Drape Rainfly over tent frame. Zipper should be out over front door and logos on each side.
- Secure Rainfly with velcro ties located on underside of fly to the tent poles. There is one in the top center and 4 attached to each pole. (illus. 11)
- Connect the four clips (found at the Rainfly corners) to the clips located at the corners of the tent. (illus. 10)
- Secure Guy Lines by extending away from tent and staking out when taut. (illus.11).

illus. 9
Rainfly clips onto pole stake loop

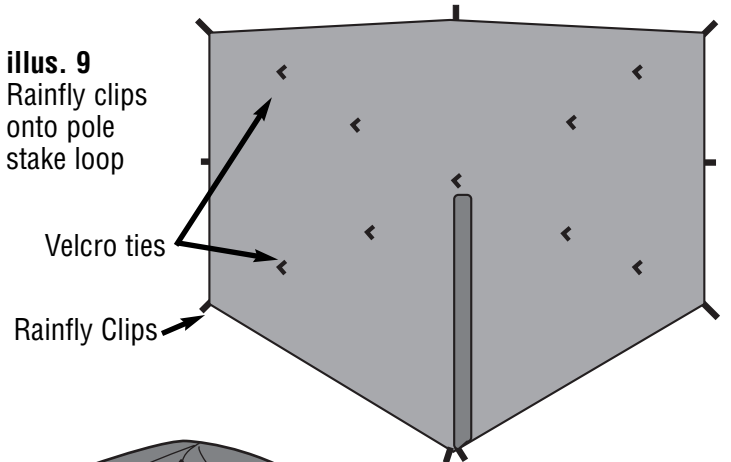

Velcro ties

Rainfly Clips

Velcro ties on underside of Rainfly attach to frame poles

Guy Line

illus. 11
Completed tent with Rainfly. Note where Rainfly clips, Guy Lines, and velcro ties are located



illus. 10
Rainfly clips onto pole stake loop

Pro-Tips

- Under certain conditions (cold weather, high humidity, etc.) condensation will form on the inside surfaces of your tent. Condensation is caused by water vapor from your breath, perspiration, or any wet clothing inside your tent. It is NOT LEAKAGE through the tent fabric. Propping open the exterior vents on the rainfly, allowing good ventilation through the tent, can minimize condensation.
- Never store tent, even for a short period of time, without drying it thoroughly and brushing off caked dirt. Do not pack stakes or poles inside your tent. Use separate storage bag.
- STAKES SHOULD BE REMOVED BY PULLING ON THE STAKE ITSELF. NEVER PULL ON THE TENT FABRIC OR TENT STAKE LOOP TO REMOVE STAKE.
- TENT POLES SHOULD NOT BE LEFT TELESCOPED TOGETHER DURING STORAGE.

