

HONDA

MARINE

BF115A/130A
Owner's
Manual



©1998 American Honda Motor Co., Inc. — All Rights Reserved



WARNING:



The engine exhaust from this product contains chemicals known to the State of California to cause cancer, birth defects, or other reproductive harm.

Keep this owner's manual handy, so you can refer to it at any time. This owner's manual is considered a permanent part of the outboard motor and should remain with the outboard motor if resold.

The information and specifications included in this publication were in effect at the time of approval for printing. Honda Motor Co., Ltd. reserves the right, however, to discontinue or change specifications or design at any time without notice and without incurring any obligation whatever. No part of this publication may be reproduced without written permission.

Congratulations on your selection of a Honda outboard motor. We are certain you will be pleased with your purchase of one of the finest outboard motors on the market.

We want to help you get the best results from your new outboard motor and to operate it safely. This manual contains the information on how to do that; please read it carefully.

As you read this manual, you will find information preceded by a **NOTICE** symbol. That information is intended to help you avoid damage to your outboard motor, other property, or the environment.

We suggest you read the warranty policy to fully understand its coverage and your responsibilities of ownership. The warranty policy is a separate document that should have been given to you by your dealer.

When your outboard motor needs scheduled maintenance, keep in mind that your Honda marine dealer is specially trained in servicing Honda outboard motors. Your Honda marine dealer is dedicated to your satisfaction and will be pleased to answer your questions and concerns.

© 1998 Honda Motor Co., Ltd.
All Right Reserved

INTRODUCTION

A FEW WORDS ABOUT SAFETY

Your safety and the safety of others are very important. And using this outboard motor safely is an important responsibility.

To help you make informed decisions about safety, we have provided operating procedures and other information on labels and in this manual. This information alerts you to potential hazards that could hurt you or others.

Of course, it is not practical or possible to warn you about all the hazards associated with operating or maintaining an outboard motor. You must use your own good judgment.

You will find important safety information a variety of forms, including:

- **Safety Labels** — on the outboard motor.
- **Safety Messages** — preceded by a safety alert symbol  and one of three signal words, DANGER, WARNING, or CAUTION.

These signal words mean:

 **DANGER**

You **WILL** be **KILLED** or **SERIOUSLY HURT** if you don't follow instructions.

 **WARNING**

You **CAN** be **KILLED** or **SERIOUSLY HURT** if you don't follow instructions.

 **CAUTION**

You **CAN** be **HURT** if you don't follow instructions.

- **Safety Headings** — such as *IMPORTANT SAFETY INFORMATION*.
- **Safety Section** — such as *OUTBOARD MOTOR SAFETY*.
- **Instructions** — how to use this outboard motor correctly and safely.

This entire book is filled with important safety information — please read it carefully.

TYPES OF HONDA BF115A/130A OUTBOARD MOTORS

It may be necessary to refer to this chart for reference purposes when reading this manual.

Model	Type	Shaft Length		Standard Rotating Propeller Shaft	Counterrotating Propeller Shaft	Power Trim/Tilt	Tachometer	Trimmer
		L	X					
BF115A	LA	●		●		●		●
	XA		●	●		●		●
	LCA	●			●	●		●
	XCA		●		●	●		●
BF130A	LA	●		●		●		●
	XA		●	●		●		●
	LCA	●			●	●		●
	XCA		●		●	●		●

TYPE CODE (example)

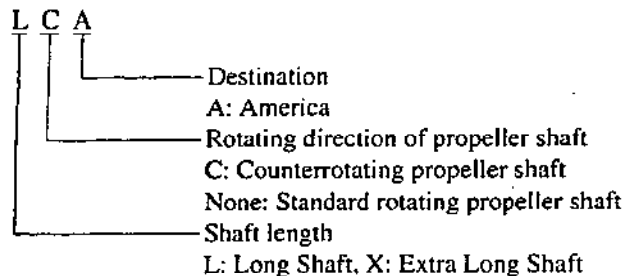

IDENTIFICATION NUMBERS

LEFT STERN BRACKET

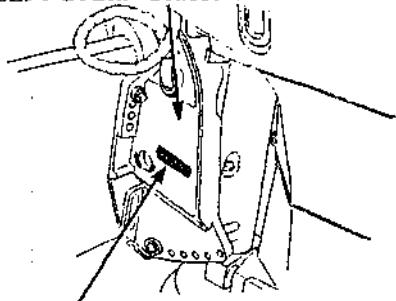

PRODUCT IDENTIFICATION NUMBER

The Product Identification Number is stamped on a plate and attached to the left stern bracket.

Product identification number:

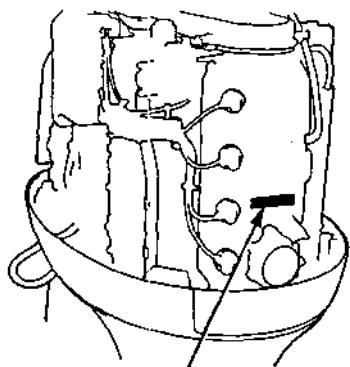

ENGINE SERIAL NUMBER

The Engine Serial Number is stamped on the cylinder head on the back of the engine.

Engine serial number:

Record the Product Identification Number (P.I.N.) and the Engine Serial Number for your reference. Refer to the Product Identification Number when ordering parts, and when making technical or warranty inquiries (see page 117).

<p>1. OUTBOARD MOTOR SAFETY IMPORTANT SAFETY INFORMATION .. 7 SAFETY LABEL LOCATIONS 9</p> <p>2. COMPONENT IDENTIFICATION .. 10</p> <p>3. CONTROLS & INSTRUMENTS SIDE-MOUNT TYPE Remote Control Lever 14 Neutral Release Lever 15 Ignition Switch 15 Emergency Stop Switch Lanyard .. 16 Fast Idle Lever 17 PGM-FI Indicator Light/Buzzer ... 17 ACG Indicator Light/Buzzer 18 Oil Pressure Indicator Light/Buzzer .. 18 Overheat Indicator Light/Buzzer... 18 Power Trim/Tilt Switch 19</p> <p>PANEL-MOUNT TYPE Remote Control Lever 20 Neutral Release Lever 21 Ignition Switch 21 Emergency Stop Switch Lanyard .. 22 Throttle Button 23 PGM-FI Indicator Light/Buzzer .. 23 ACG Indicator Light/Buzzer 23 Oil Pressure Indicator Light/Buzzer .. 24 Overheat Indicator Light/Buzzer... 24 Power Trim/Tilt Switch 25</p> <p>TOP-MOUNT TYPE Remote Control Lever 26 Ignition Switch 27</p>	<p>Emergency Stop Switch Lanyard .. 28 Throttle Button 29 PGM-FI Indicator Light/Buzzer .. 29 ACG Indicator Light/Buzzer 29 Oil Pressure Indicator Light/Buzzer .. 30 Overheat Indicator Light/Buzzer ... 30 Power Trim/Tilt Switch (remote control lever) . 31 Power Trim/Tilt Switch (control box console).. 31</p> <p>COMMON Power Tilt Switch (engine pan) .. 32 Trim Meter 32 Tachometer (optional equipment)... 32 Manual Relief Valve 33 Tilt Lock Lever 34 Trim Tab 34 Anodes 35 Cooling System Indicator 35 Water Intakes 35 Transom Angle Adjusting Rod ... 36 Fuel Cap/Gauge/Vent Knob (optional fuel tank) 37 Overrev Limiter 37 Engine Cover Lock Lever 38 Fuel Hose Connector 38</p> <p>4. PRE-OPERATION CHECKS Engine Cover Removal/Installation.. 39 Engine Oil 40 Fuel Level (optional fuel tank) .. 41</p>	<p>Fuel Recommendations 42 Oxygenated Fuels 43 Propeller and Cotter Pin 44 Control Lever Friction Adjustment 45 Engine Cover Lock Lever Adjustment 46 Other Checks • Fuel hose 47 • Stern bracket 47 • Tool Kit 47 • Anodes 47</p> <p>5. STARTING THE ENGINE Optional Fuel Tank 48 Fuel Line Connection 48</p> <p>STARTING THE ENGINE (SIDE-MOUNT TYPE) 50 (PANEL-MOUNT TYPE) 53 (TOP-MOUNT TYPE) 56 Troubleshooting Starting Problems.. 59</p> <p>6. OPERATION Break-in Procedure 60</p> <p>SIDE-MOUNT TYPE Gear Shifting 61 Cruising 62</p> <p>PANEL-MOUNT TYPE Gear Shifting 63 Cruising 64</p> <p>TOP-MOUNT TYPE Gear Shifting 65</p>
---	---	--

CONTENTS

Cruising	66	Oil Filter	96
POWER TRIM/TILT		Gear Oil	98
Power Trim/Tilt System	67	Spark Plugs	99
Trim Meter	69	Battery (not included)	100
Power Tilt Switch (engine pan) ..	70	Lubrication	102
Manual Relief Valve	70	Engine Fuel Filter	103
Tilt Lock Lever	71	Fuel Tank and Filter	105
Trim Tab Adjustment	72	Fuse Replacement	106
MOTOR PROTECTION SYSTEM		Propeller	108
Engine Oil Pressure, Overheat, PGM-FI and ACG Indicator		Submerged Motor	109
Systems	73	11. STORAGE	111
Overrev Limiter	76	12. TROUBLESHOOTING	114
Anodes	76	13. SPECIFICATIONS	115
Shallow Water Operation	77	14. WARRANTY SERVICE	117
7. STOPPING THE ENGINE		15. INDEX	118
(SIDE-MOUNT TYPE)	78	16. WIRING DIAGRAM	121
(PANEL-MOUNT TYPE)	79		
(TOP-MOUNT TYPE)	80		
8. TRANSPORTING	81		
9. CLEANING AND FLUSHING ..	84		
10. MAINTENANCE	86		
THE IMPORTANCE OF MAINTENANCE	86		
MAINTENANCE SAFETY	87		
EMISSION CONTROL SYSTEM INFORMATION	87		
Tool Kit and Spare Parts	90		
MAINTENANCE SCHEDULE	91		
Engine Oil	93		

1. OUTBOARD MOTOR SAFETY

IMPORTANT SAFETY INFORMATION

Honda BF115A and BF130A outboard motors are designed for use with boats that have a suitable manufacturer's power recommendation, and other uses can result in injury to the operator or damage to the outboard motor and other property.

Most accidents can be prevented if you follow all instructions in this manual and on the outboard motor. The most common hazards are discussed below, along with the best way to protect yourself and others.

Operator Responsibility

- It is the operator's responsibility to provide the necessary safeguards to protect people and property. Know how to stop the engine quickly in case of emergency. Understand the use of all controls.
- Stop the engine immediately if anyone falls overboard, and do not run the engine while the boat is near anyone in the water.
- Always stop the engine if you must leave the controls for any reason.
- Attach the emergency stop switch lanyard securely to the operator.
- Always wear a PFD (Personal Flotation Device) while on the boat.
- Familiarize yourself with all laws and regulations relating to boating and the use of outboard motors.
- Be sure that anyone who operates the outboard motor receives proper instruction.
- Be sure the outboard motor is properly mounted on the boat.
- Do not remove the engine cover while the engine is running.
- Do not attempt to modify the outboard motor.
- Do not remove any labels, covers, or safety devices; they are installed for your safety.

1. OUTBOARD MOTOR SAFETY

Refuel With Care

- Gasoline is extremely flammable, and gasoline vapor can explode. Refuel outdoors, in a well-ventilated area, with the engine stopped. Never smoke near gasoline, and keep other flames and sparks away.
- Remove any portable fuel tank from the boat for refueling. Keep the portable fuel tank away from the battery or other potential spark sources.
- Refuel carefully to avoid spilling fuel. Avoid overfilling the fuel tank.
- After refueling, tighten the filler cap securely. If any fuel is spilled, make sure the area is dry before starting the engine.

Carbon Monoxide Hazard

Exhaust gas contains poisonous carbon monoxide. Avoid inhalation of exhaust gas. Never run the engine in a closed garage or confined area.

1. OUTBOARD MOTOR SAFETY

SAFETY LABEL LOCATIONS

These labels are in the locations shown. They warn you of potential hazards that could seriously injure you. Read these labels carefully.

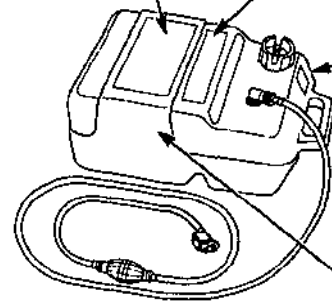
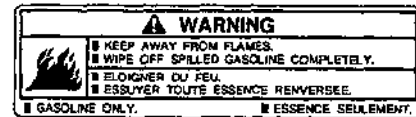
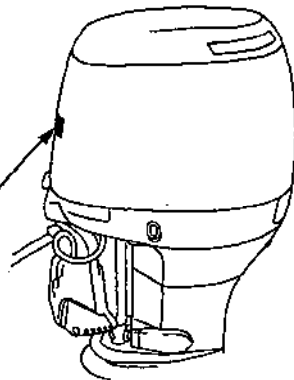
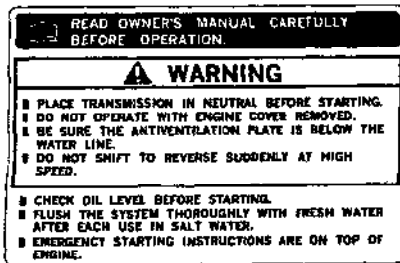
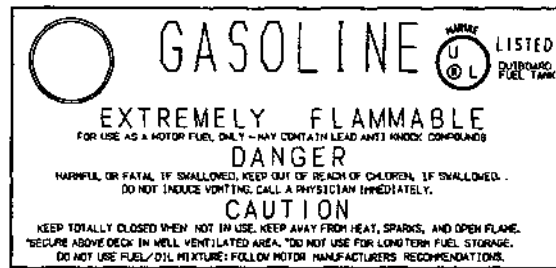

OPTIONAL FUEL TANK



2. COMPONENT IDENTIFICATION

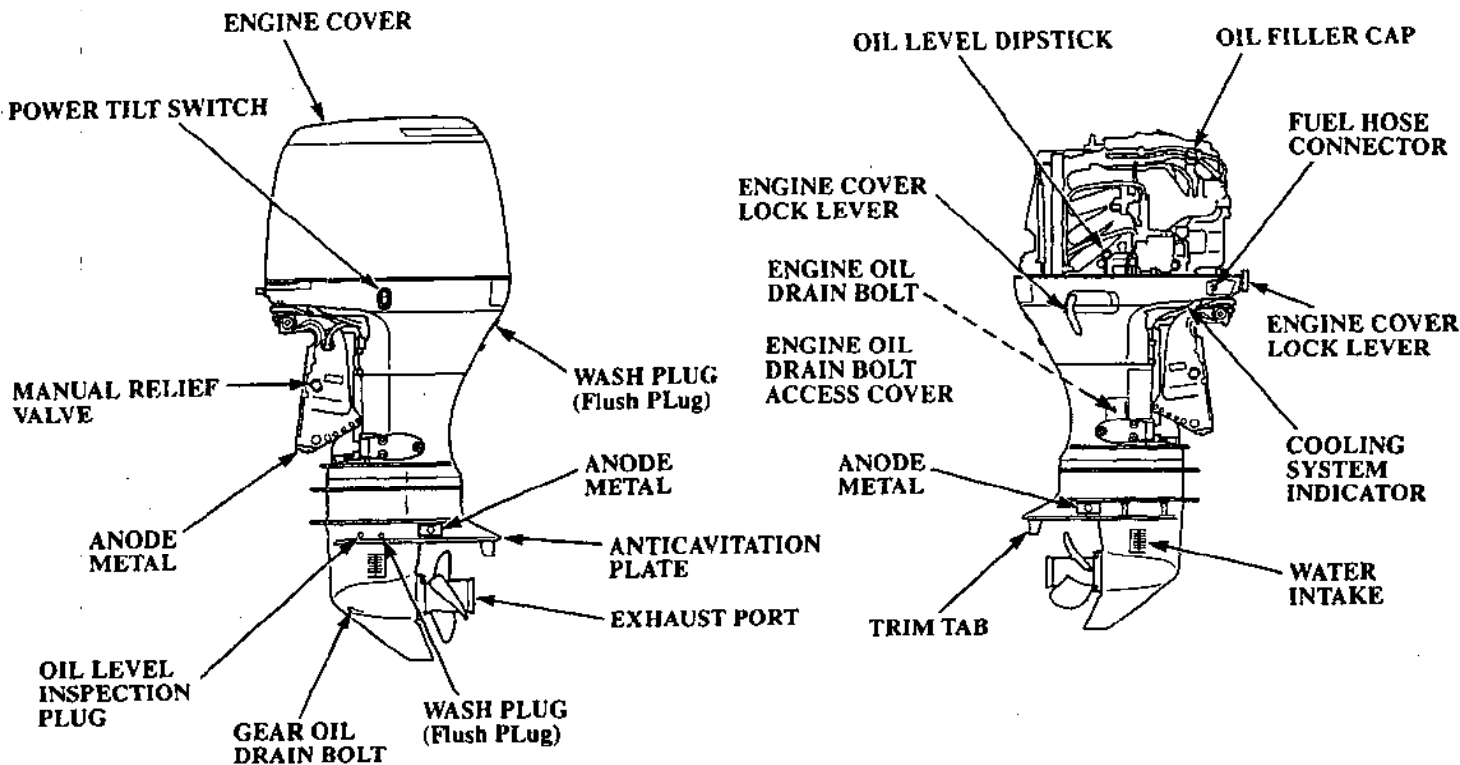

2. COMPONENT IDENTIFICATION

(SIDE-MOUNT REMOTE CONTROL)

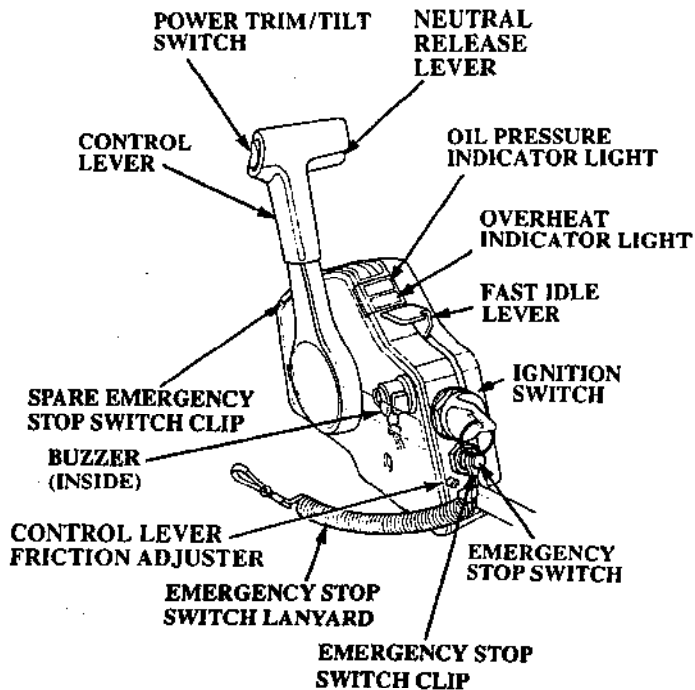

(PANEL-MOUNT REMOTE CONTROL)

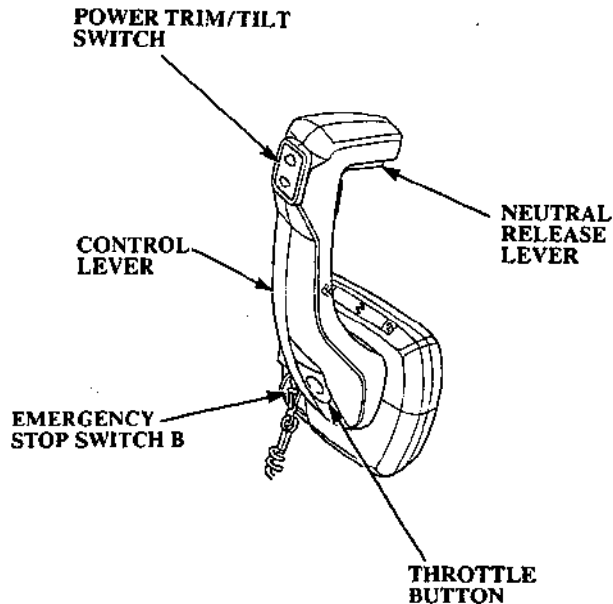

2. COMPONENT IDENTIFICATION

(SINGLE TOP-MOUNT
REMOTE CONTROL)

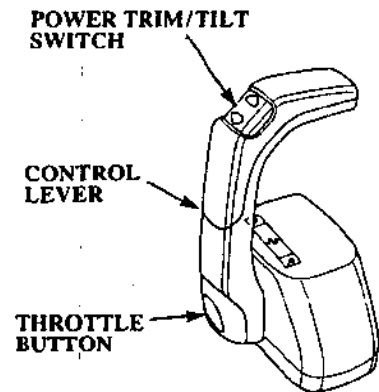

(DUAL TOP-MOUNT
REMOTE CONTROL)

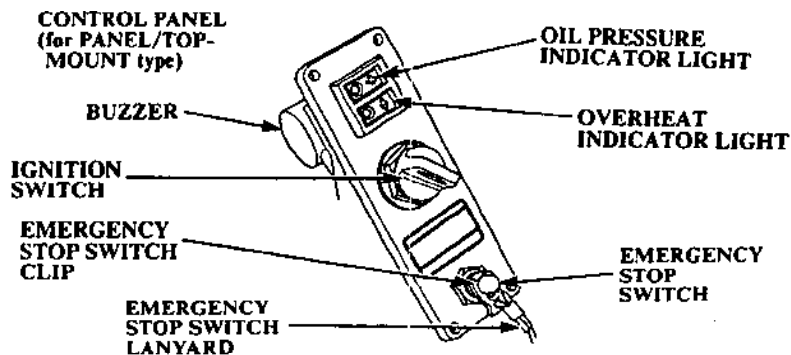
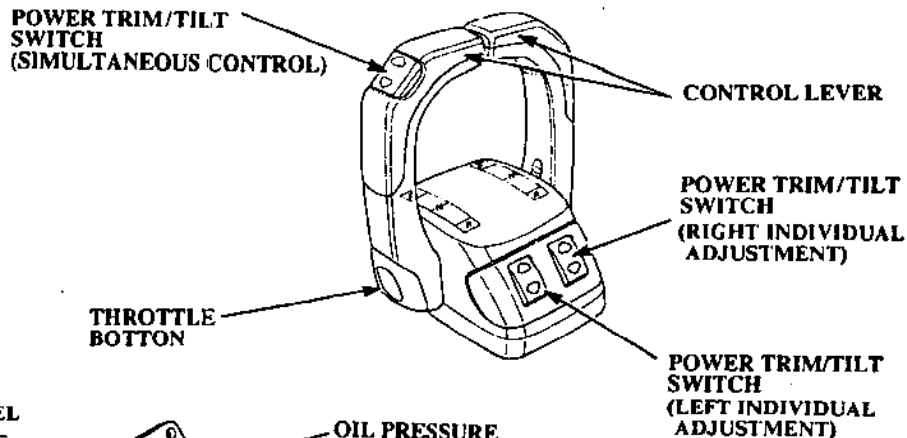

2. COMPONENT IDENTIFICATION

FUEL TANK (optional equipment)

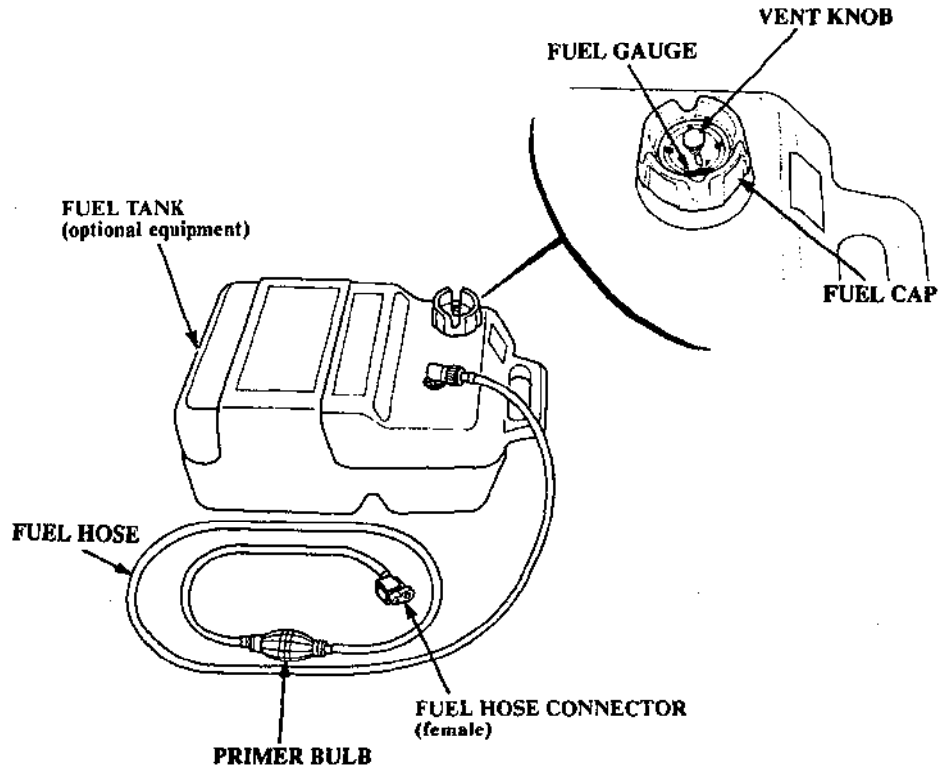

METER

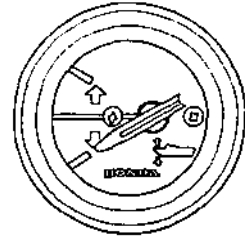

TRIM METER

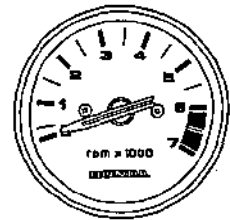

TACHOMETER (optional equipment)

3. CONTROLS (SIDE-MOUNT TYPE)

(SIDE-MOUNT TYPE) Remote Control Lever

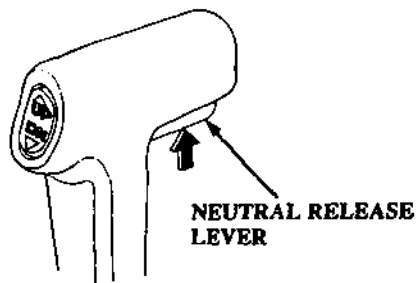

The remote control lever controls gear selection and throttle opening positions.

It is necessary to pull up the neutral release lever to operate the remote control lever.

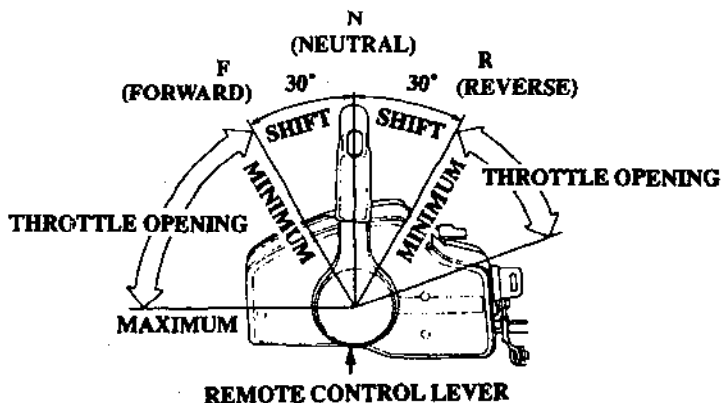

F (forward):

Moving the lever to the F position (approximately 30° from the N position) will engage the forward gear. Moving the lever farther into the F position will increase the throttle opening and the boat's forward speed.

N (neutral):

The engine idles and the transmission gears are disengaged.

R (reverse):

Moving the lever to the R position (approximately 30° from the N position) will engage the reverse gear. Moving the lever farther into the R position will increase the throttle opening and the boat's reverse speed.

3. CONTROLS (SIDE-MOUNT TYPE)

Neutral Release Lever

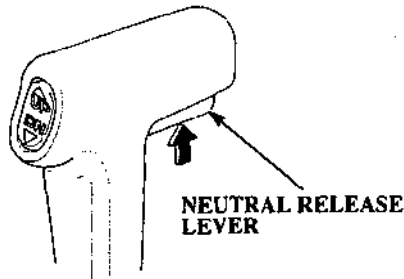

The neutral release lever is on the remote control lever to prevent an accidental gear engagement.

The remote control lever will not engage forward or reverse gear, unless the neutral release lever is pulled up.

Ignition Switch

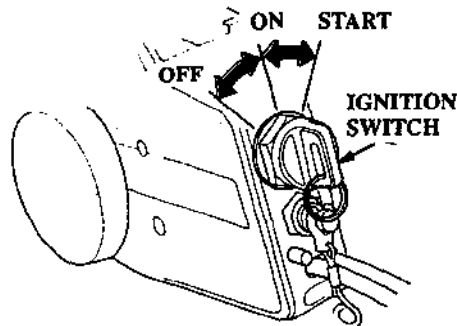

The remote control box is equipped with a key-type ignition switch. Key positions:

START

To activate the starter motor and start the engine (the remote control lever must be in the neutral position).

ON

To run the engine after starting (the battery will discharge if the key is left in this position with the engine not running).

OFF

To stop the engine (IGNITION OFF).

To prevent the battery from discharging, keep the key in the OFF position when the engine is not running.

3. CONTROLS (SIDE-MOUNT TYPE)

Emergency Stop Switch Lanyard

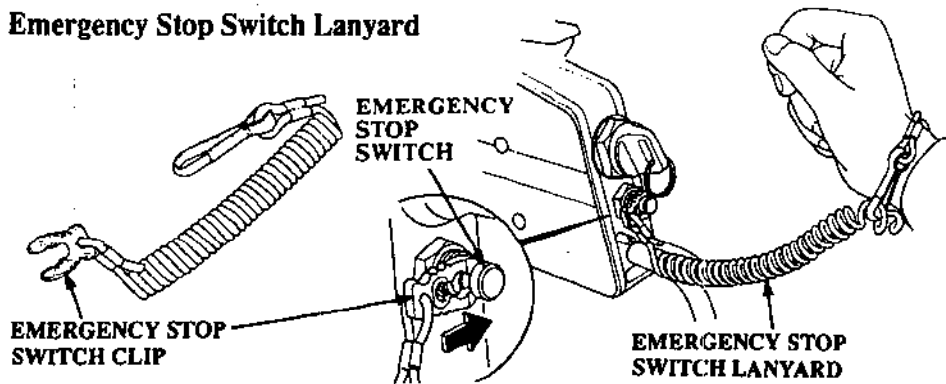

The emergency stop switch lanyard is provided to stop the engine immediately in the event the operator falls overboard or away from the controls.

The emergency stop switch clip must be engaged with the emergency stop switch, or the engine will not start. When the emergency stop switch clip becomes disengaged from the emergency stop switch, the engine will stop immediately.

The emergency engine stop switch should not be used to normally stop the engine. Use the ignition switch to normally stop the engine.

Attach the emergency stop switch lanyard securely to the operator when operating the outboard motor.

The lanyard can be attached to the operator's PFD (personal Flotation Device) or worn around the wrist as shown.

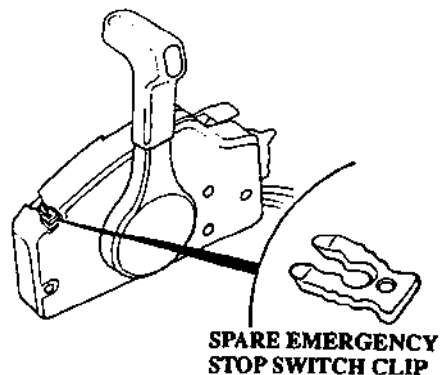

A spare emergency stop switch clip is provided on the remote control box.

3. CONTROLS (SIDE-MOUNT TYPE)

Fast Idle Lever

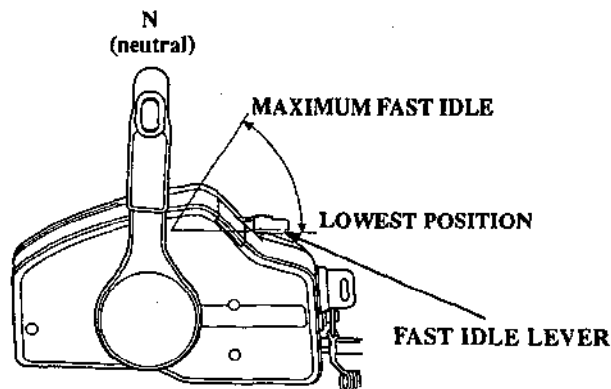

The fast idle lever provides fast idle for easy engine start up.

The fast idle lever will not move unless the remote control lever is in the N (neutral) position. Conversely, the remote control lever will not move unless the fast idle lever is in the lowest position.

Raise the fast idle lever, and hold it all the way up to provide maximum fast idle.

Gradually lower the fast idle lever to the lowest position to decrease the fast idle.

PGM-FI Indicator Light/Buzzer

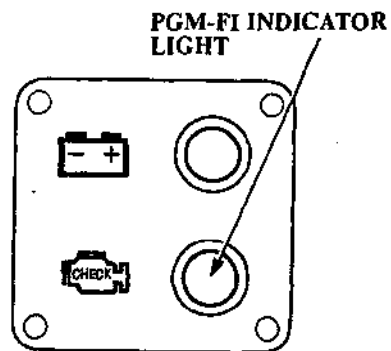

The PGM-FI indicator light turns on and the buzzer sounds when the engine control system is faulty, and when the ignition key is turned from OFF to ON.

3. CONTROLS (SIDE-MOUNT TYPE)

ACG Indicator Light/Buzzer

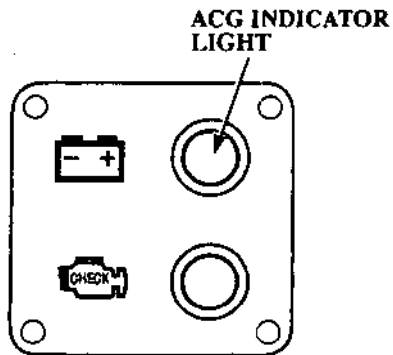

The ACG indicator light turns on and the buzzer sounds when the charging system is faulty.

Oil Pressure Indicator Light/Buzzer

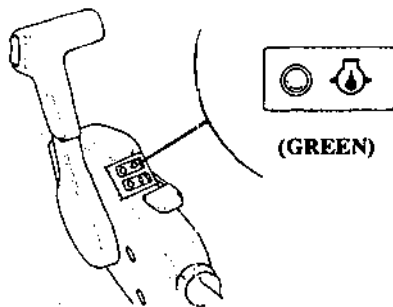

The green oil pressure indicator light turns OFF and the buzzer sounds when the oil level is low and/or the engine lubrication system is faulty. The engine speed slows down gradually.

The oil pressure indicator light is normally ON while the engine is running.

Overheat Indicator Light/Buzzer

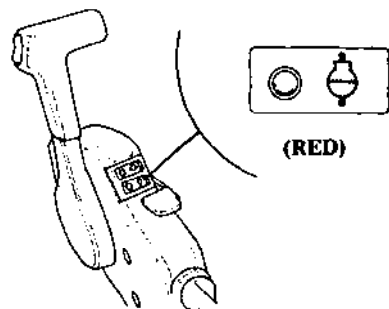

The red overheat indicator light turns ON and the buzzer sounds when there is a cooling system problem. The engine speed slows down gradually.

3. CONTROLS (SIDE-MOUNT TYPE)

Power Trim/Tilt Switch

Power Trim

Press the power trim/tilt switch on the remote control to adjust the motor trim angle from 0° to 20° to maintain proper boat trim. The power trim/tilt switch located on the remote control lever can be operated while the boat is under way or while stopped.

By using the power trim/tilt switch, the operator can change the trim angle of the motor to achieve maximum boat acceleration, speed, stability and maintain optimum fuel consumption.

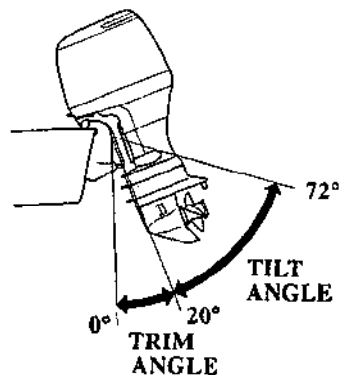

Power Tilt

Press the power trim/tilt switch on the remote control lever to adjust the motor tilt angle from 20° to 72° .

By using the power trim/tilt switch, the operator can change the tilt angle of the motor for shallow water operation, beaching, launching from a trailer, or mooring.

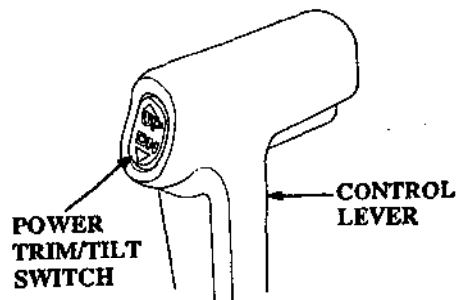

NOTICE

Excessive trim/tilt angle during operation can cause the propeller to raise out of the water and cause propeller ventilation and engine over-revving. Excessive trim/tilt angle can also damage the water pump.

3. CONTROLS (PANEL-MOUNT TYPE)

(PANEL-MOUNT TYPE)

Remote Control Lever

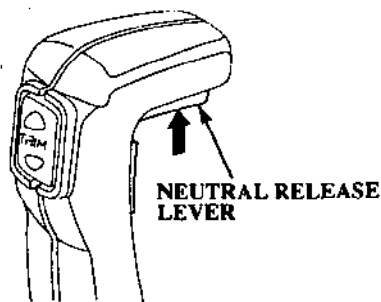

The remote control lever controls gear selection and throttle opening positions.

It is necessary to pull up the neutral release lever to operate the remote control lever.

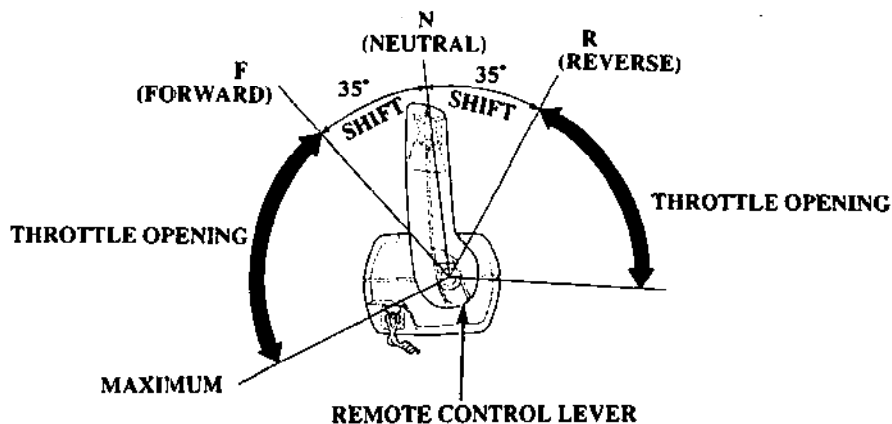

F (forward):

Moving the lever to the F position (approximately 35° from the N position) will engage the forward gear. Moving the lever farther into the F position will increase the throttle opening and the boat's forward speed.

N (neutral):

The engine idles and the transmission gears are disengaged.

R (reverse):

Moving the lever to R position (approximately 35° from the N position) will engage the reverse gear. Moving the lever farther into the R position will increase the throttle opening and the boat's reverse speed.

3. CONTROLS (PANEL-MOUNT TYPE)

Neutral Release Lever

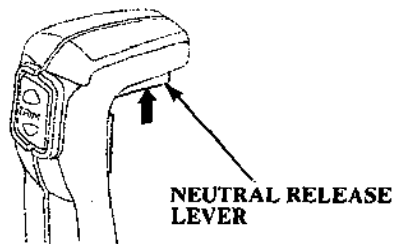

The neutral release lever is on the remote control lever to prevent an accidental gear engagement.

The remote control lever will not engage forward or reverse gear, unless the neutral release lever is pulled up.

Ignition Switch

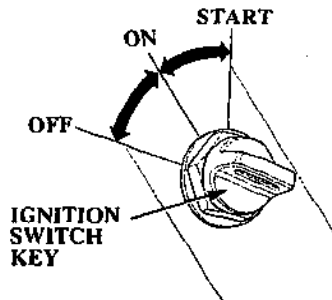

The switch panel is equipped with a key-type ignition switch.

Key positions:

START

To activate the starter motor and start the engine (the remote control lever must be in the neutral position).

ON

To run the engine after starting (the battery will discharge if the key is left in this position with the engine not running).

OFF

To stop the engine (IGNITION OFF).
To prevent the battery from discharging, keep the key in the OFF position when the engine is not running.

3. CONTROLS (PANEL-MOUNT TYPE)

Emergency Stop Switch Lanyard

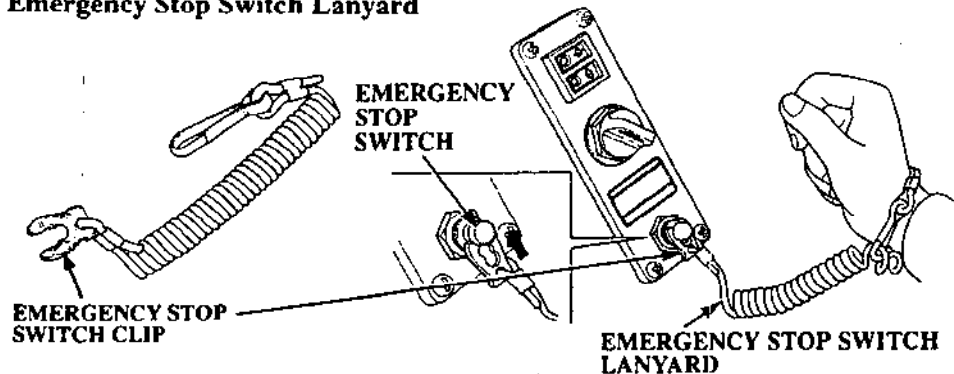

The emergency stop switch lanyard is provided to stop the engine immediately in the event the operator falls overboard or away from the controls.

The emergency stop switch clip must be engaged with the emergency stop switch, or the engine will not start. When the emergency stop switch clip becomes disengaged from the emergency stop switch, the engine will stop immediately.

The emergency engine stop switch should not be used to normally stop the engine. Use the ignition switch to normally stop the engine.

Attach the emergency stop switch lanyard securely to the operator when operating the outboard motor.

The lanyard can be attached to the operator's PFD (personal Flotation Device) or worn around the wrist as shown.



SPARE EMERGENCY STOP SWITCH CLIP

A spare emergency switch clip is provided in the tool bag.

3. CONTROLS (PANEL-MOUNT TYPE)

Throttle Button

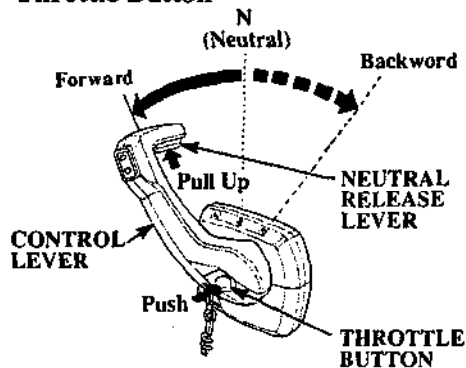

By moving the control lever forward or backward when the throttle button is pushed in, the throttle opening will be increased without engaging the gears.

It is necessary to position the control lever in N (neutral) to push in the throttle button.

PGM-FI Indicator Light/Buzzer

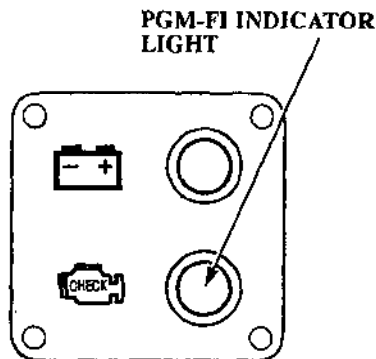

The PGM-FI indicator light turns on and the buzzer sounds when the engine control system is faulty and when the ignition key is turned from OFF to ON.

ACG Indicator Light/Buzzer

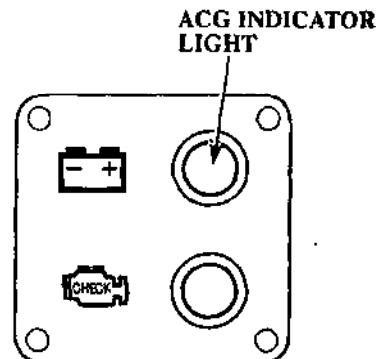

The ACG indicator light turns on and the buzzer sounds when the charging system is faulty.

3. CONTROLS (PANEL-MOUNT TYPE)

Oil Pressure Indicator Light/Buzzer

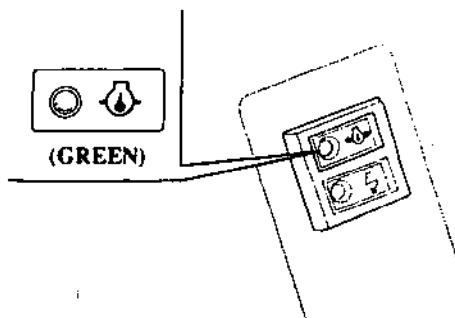

The green oil pressure indicator light turns OFF and the buzzer sounds when the oil level is low and/or the engine lubrication system is faulty. The engine speed slows down gradually.

The oil pressure indicator light is normally ON while the engine is running.

Overheat Indicator Light/Buzzer

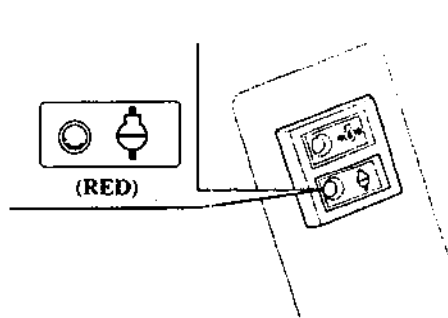

The red overheat indicator light turns ON and the buzzer sounds when there is a cooling system problem. The engine speed slows down gradually.

3. CONTROLS (PANEL-MOUNT TYPE)

Power Trim/Tilt Switch

Power Trim

Press the power trim/tilt switch on the remote control lever to adjust the motor trim angle from 0° to 20° to maintain proper boat trim. The power trim/tilt switch located on the remote control lever can be operated while the boat is under way or while stopped.

By using the power trim/tilt switch, the operator can change the trim angle of the motor to achieve maximum boat acceleration, speed, stability and maintain optimum fuel consumption.

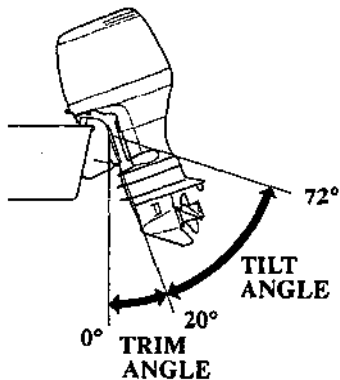

Power Tilt

Press the power trim/tilt switch on the remote control lever to adjust the motor tilt angle from 20° to 72° .

By using the power trim/tilt switch, the operator can change the tilt angle of the motor for shallow water operation, beaching, launching from a trailer, or mooring.

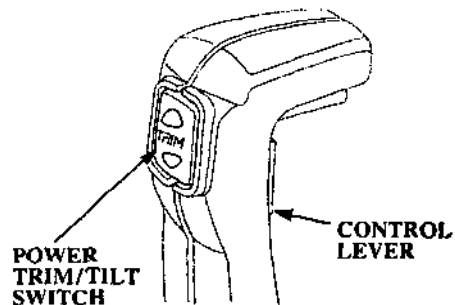

NOTICE

Excessive trim/tilt angle during operation can cause the propeller to raise out of the water and cause propeller ventilation and engine over-revving. Excessive trim/tilt angle can also damage the water pump.

3. CONTROLS (TOP-MOUNT TYPE)

(TOP-MOUNT TYPE) Remote Control Lever

SINGLE TYPE

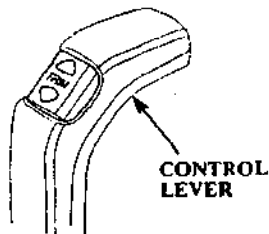

DUAL TYPE

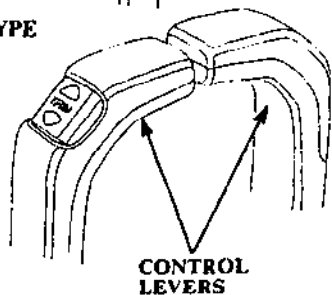

The remote control lever controls gear selection and throttle opening positions.

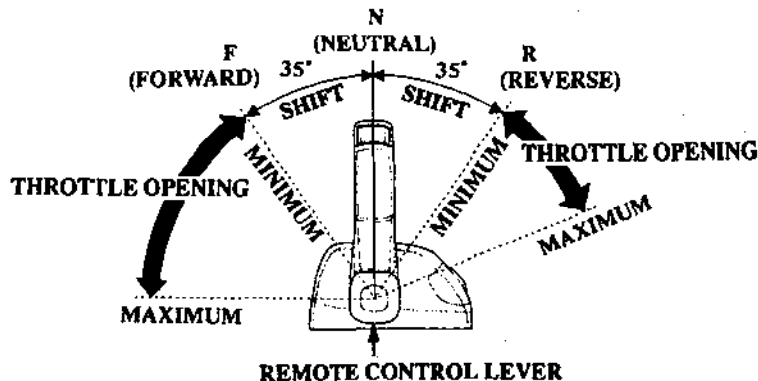

F (forward):

Moving the lever to the F position (approximately 35° from the N position) will engage the forward gear. Moving the lever farther into the F position will increase the throttle opening and the boat's forward speed.

N (neutral):

The engine idles and the transmission gears are disengaged.

R (reverse):

Moving the lever to the R position (approximately 35° from the N position) will engage the reverse gear. Moving the lever farther into the R position will increase the throttle opening and the boat's reverse speed.

3. CONTROLS (TOP-MOUNT TYPE)

Ignition Switch

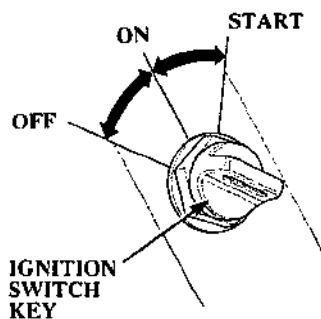

The switch panel is equipped with a key-type ignition switch.

Key positions:

START

To activate the starter motor and start the engine (the remote control lever must be in neutral position).

ON

To run the engine after starting (the battery will discharge if the key is left in this position with the engine not running).

OFF

To stop the engine (IGNITION OFF).

To prevent the battery from discharging, keep the key in the OFF position when the engine is not running.

3. CONTROLS (TOP-MOUNT TYPE)

Emergency Stop Switch Lanyard

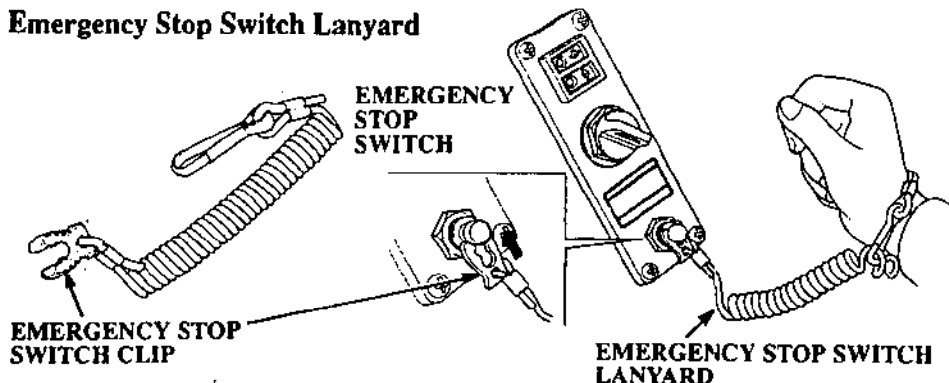

SPARE EMERGENCY STOP SWITCH CLIP

The emergency stop switch lanyard is provided to stop the engine immediately in the event the operator falls overboard or away from the controls.

The emergency stop switch clip must be engaged with the emergency stop switch, or the engine will not start. When the emergency stop switch clip becomes disengaged from the emergency stop switch, the engine will stop immediately.

The emergency engine stop switch should not be used to normally stop the engine. Use the ignition switch to normally stop the engine.

Attach the emergency stop switch lanyard securely to the operator when operating the outboard motor.

The lanyard can be attached to the operator's PFD (personal Flotation Device) or worn around the wrist as shown.

A spare emergency switch clip is provided in the tool bag.

3. CONTROLS (TOP-MOUNT TYPE)

Throttle Button

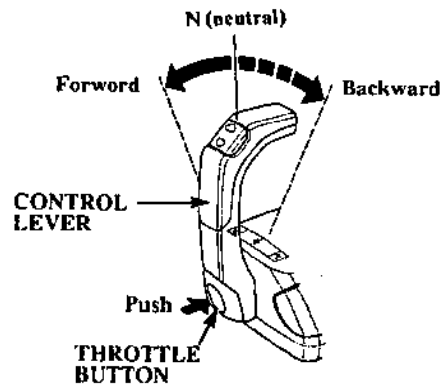

By moving the control lever forward or backward when the throttle button is pushed in, the throttle opening will be increased without engaging the gears.

It is necessary to position the control lever in N (neutral) to push in the throttle button.

PGM-FI Indicator Light/Buzzer

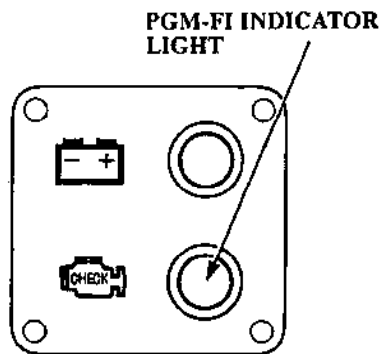

The PGM-FI indicator light turns on and the buzzer sounds when the engine control system is faulty and when the ignition key is turned from OFF to ON.

ACG Indicator Light/Buzzer

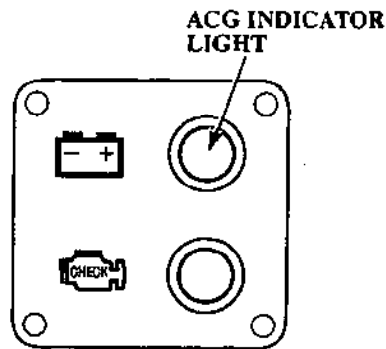

The ACG indicator light turns on and the buzzer sounds when the charging system is faulty.

3. CONTROLS (TOP-MOUNT TYPE)

Oil Pressure Indicator Light/Buzzer

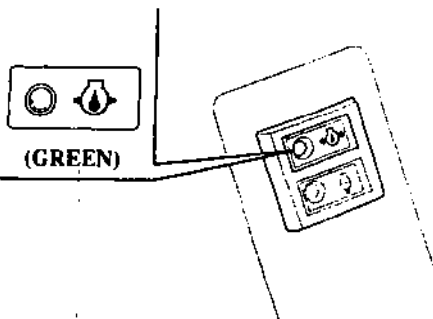

The green oil pressure indicator light turns OFF and the buzzer sounds when the oil level is low and/or the engine lubrication system is faulty. The engine speed slows down gradually.

The oil pressure indicator light is normally ON while the engine is running.

Overheat Indicator Light/Buzzer

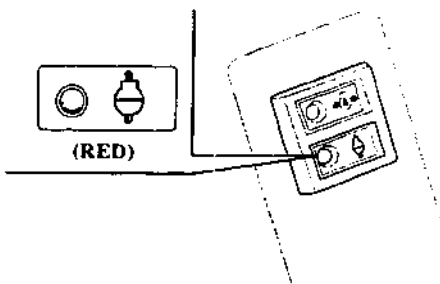

The red overheat indicator light turns ON and the buzzer sounds when there is a cooling system problem. The engine speed slows down gradually.

3. CONTROLS (TOP-MOUNT TYPE)

Power Trim/Tilt Switch (remote control lever)

Power Trim

Press the power trim/tilt switch on the remote control lever to adjust the motor trim angle from 0° to 20° to maintain proper boat trim. The power trim/tilt switch located on the remote control lever can be operated while the boat is under way or while stopped.

By using the power trim/tilt switch, the operator can change the trim angle of the motor to achieve maximum boat acceleration, speed, stability and maintain optimum fuel consumption.

Power Tilt

Press the power trim/tilt switch on the remote control lever to adjust the motor tilt angle from 20° to 72°.

By using the power trim/tilt switch, the operator can change the tilt angle of the motor for shallow water operation, beaching, launching from a trailer, or mooring.

SINGLE TYPE

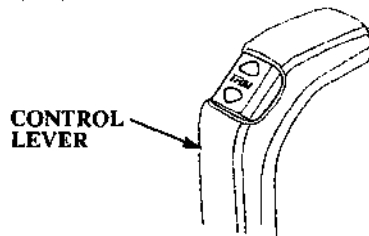

DUAL TYPE

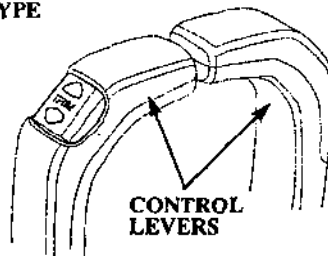

NOTICE

Excessive trim/tilt angle during operation can cause the propeller to raise out of the water and cause propeller ventilation and engine over-revving. Excessive trim/tilt angle can also damage the water pump.

Power Trim/Tilt Switch (control box console)

LEFT INDIVIDUAL ADJUSTMENT

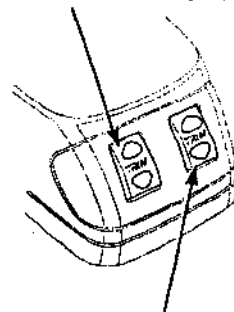

RIGHT INDIVIDUAL ADJUSTMENT

The right and left outboard motors can be adjusted separately with the switch on the console side.

3. CONTROLS (COMMON)

Power Tilt Switch (engine pan)

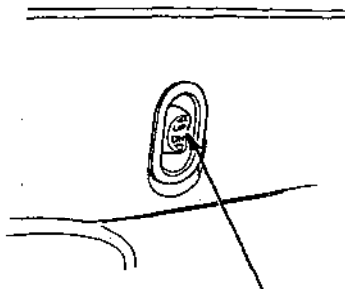

POWER TILT SWITCH

The power tilt switch located on the engine pan is for tilting the motor for trailering, or performing outboard maintenance. This power tilt switch should only be operated with the boat stopped and engine off.

This switch can operate even when the ignition switch is OFF.

Trim Meter

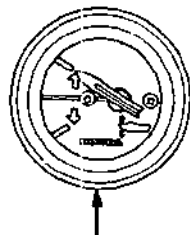

TRIM METER

The trim meter has a range of 0° to 20° and indicates the trim angle of the outboard motor. Refer to the trim meter when using the power trim/tilt switch to achieve proper boat performance.

Tachometer (optional equipment)

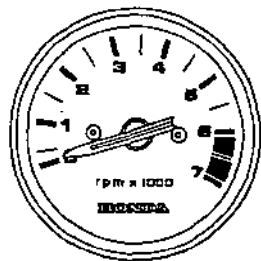

TACHOMETER

The tachometer shows the approximate engine speed in revolutions per minute. Refer to the tachometer when using the power trim/tilt switch to achieve proper boat and engine performance.

Manual Relief Valve

If the power trim/tilt switch will not tilt the outboard motor, the motor can be manually tilted up or down by opening the manual relief valve. To tilt the outboard motor manually, turn the manual valve under the left stern bracket no more than 1 or 2 turns counterclockwise using a screw driver.

After tilting the motor, turn the manual relief valve clockwise securely. The manual relief valve must be tightened securely before operating the motor or the motor could tilt up when operating in reverse.

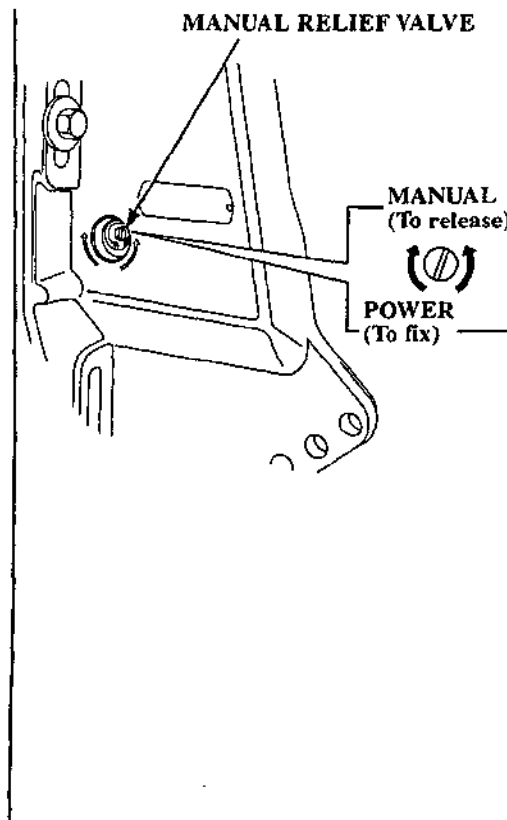

3. CONTROLS (COMMON)

Tilt Lock Lever

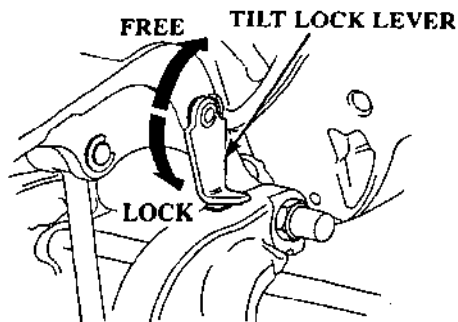

Use the tilt lock lever to hold the motor in the highest tilt position when the boat is moored for a long time.

Tilt the motor up as far as it will go, then move the tilt lock lever into the lock position and gently lower the motor.

NOTICE

Hitting piers or other boats when the motor is tilted can cause damage.

Be especially careful to prevent the boat from bumping anything while the motor is tilted.

Do not attempt to tilt the outboard motor down while the tilt lock lever is in the lock position. Damage to the power tilt system may occur.

Trim Tab

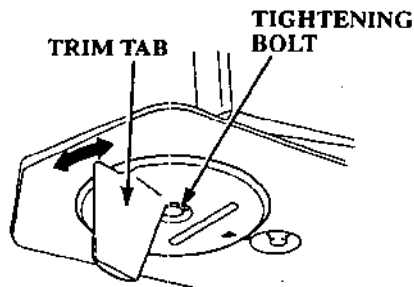

When making a turn, if an unequal amount of effort is required to turn the steering wheel right or left, adjust the trim tab so that an equal amount of effort is required.

Distribute the load evenly in the boat, and run the boat in straight course at full throttle. Slightly turn the steering wheel or tiller handle for both right and left turns to determine if an equal amount of effort is required. If adjustment is necessary, loosen the tightening bolt and turn the trim tab right or left. Make small adjustments at a time and retest. Incorrect trim tab adjustment can cause adverse steering. The trim tab also functions as an anode.

Anodes

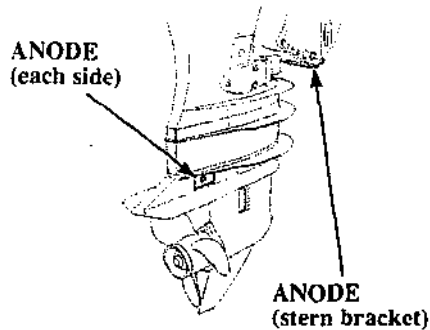

The anodes are made from a sacrificial material which helps to protect the outboard motor from corrosion.

NOTICE

Painting or coating the anodes will lead to rust and corrosion damage to the outboard motor.

Cooling System Indicator

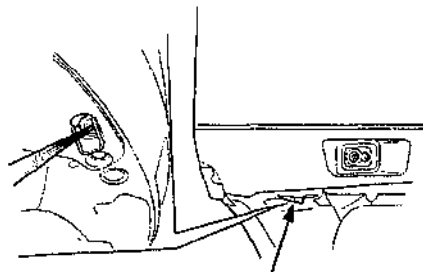

The cooling system is monitored here to make sure cooling water is circulating through the engine.

Water flowing out of the cooling system indicator shows that the cooling system is functioning normally.

Water Intakes

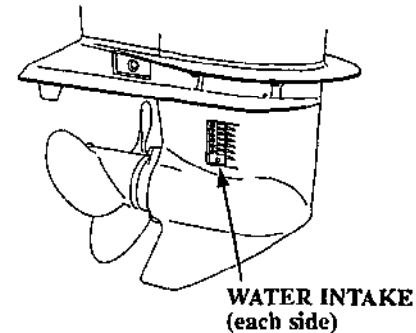

The engine cooling water is drawn into the water pump through these water intakes.

3. CONTROLS (COMMON)

Transom Angle Adjusting Rod

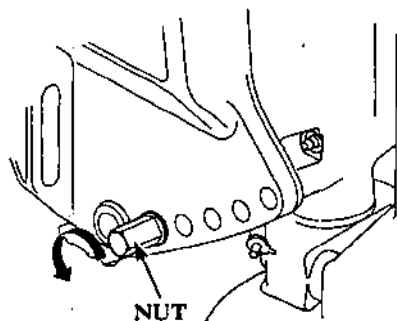

The transom angle adjusting rod limits the angle of the outboard motor when fully lowered.

Proper adjustment prevents the outboard motor from being trimmed too low.

To adjust, first tilt the outboard motor so it is not resting against the rod. Remove the nut, then remove the rod and insert it in the desired position. Reinstall the nut and tighten it securely.

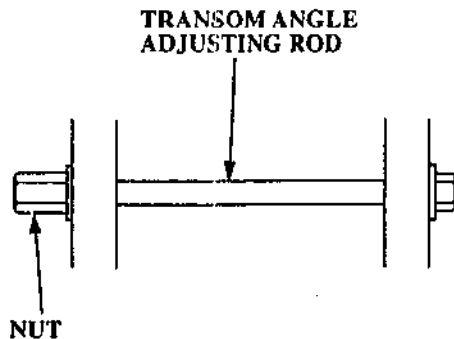

Start with the transom angle adjusting rod in the hole closest to the boat transom, lower the motor and operate the boat at full speed. If the bow is excessively low stop the boat. Tilt the motor up and raise the transom angle adjusting rod one more hole away from the transom and retest. The optimum boat trim is when the boat is parallel with the water.

The motor should never be operated with the transom angle adjusting rod removed.

Fuel Cap/Gauge/Vent Knob (optional fuel tank)

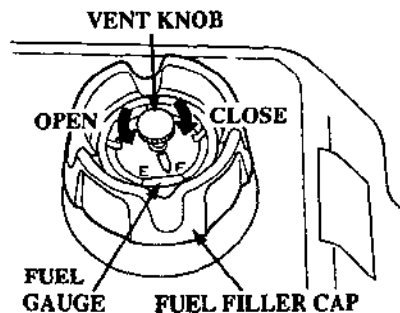

The fuel gauge is part of the fuel cap.

The fuel cap vent knob controls air entering and leaving the fuel tank. When refilling the fuel tank, turn the vent knob counterclockwise to the open position and remove the fuel cap.

Before transporting, storing or refilling the fuel tank, inspect the condition of the fuel cap gasket and replace if necessary.

Before transporting or storing the fuel tank, turn the vent knob fully clockwise to the closed position.

Anytime the fuel tank is in the boat with the vent knob closed, disconnect the fuel hose connector from the outboard motor (refer to page 48).

⚠WARNING Gasoline is highly flammable and explosive. You can be burned or seriously injured when handling fuel.

- Stop engine and keep heat, sparks and flame away.
- Handle fuel only outdoors.
- Wipe up spills immediately.

Overrev

This outboard motor is equipped with an engine overrev limiter which limits the maximum engine rpm. This overrev limiter protects the engine from mechanical damage.

The overrev limiter may be activated by putting the propeller in a light load condition or propeller ventilation. When the overrev limiter is activated, the engine rpm will become unstable or erratic. Should this occur, reduce the throttle opening and wait for the engine rpm to stabilize, then increase the throttle opening.

Lower the trim angle on high speed turns to reduce the possibility of propeller ventilation.

If the overrev limiter activates when trim/tilt angle is correct, stop the engine and check for mounting problems and propeller damage. If mounted improperly, fix it. If the propeller is damaged, replace it.

3. CONTROLS (COMMON)

Engine Cover Lock Levers

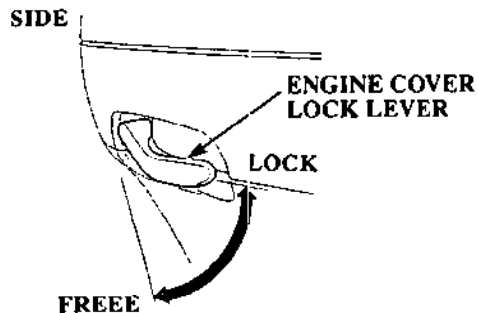
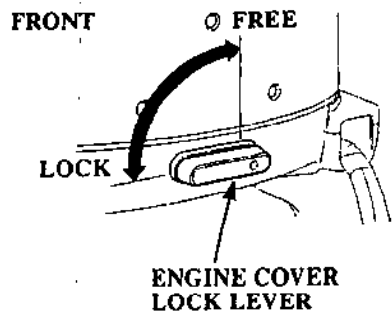

The engine cover lock levers are used to fasten the engine cover.

To open and remove the engine cover, turn the front and side lock levers clockwise to the FREE position.

To fasten the engine cover, set the engine cover in position and turn the lock levers to the LOCK position.

Fuel Hose Connectors

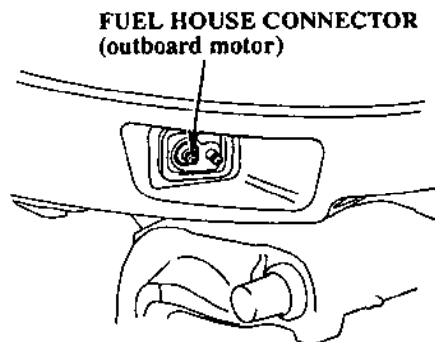

FUEL HOSE CONNECTOR (optional, portable fuel tank)

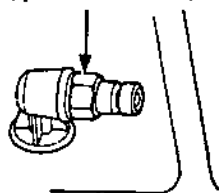

Refer to pages 48-49 for fuel hose connection.

Engine Cover Removal/Installation

FRONT

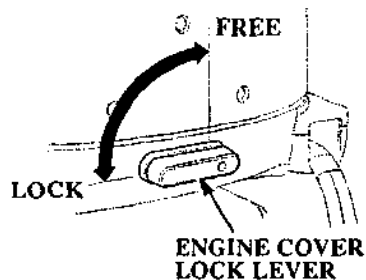

To remove, turn the front and side engine cover lock levers to the FREE position and remove the engine cover.

SIDE

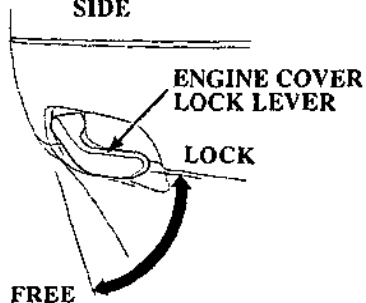

To install, position the engine cover over the engine and turn the front and side lock levers on the LOCK position.

After installing the engine cover, inspect the engine cover fastening condition and adjust it if necessary (page 46).

4. PRE-OPERATION CHECKS

Engine Oil

Engine oil is a major factor affecting engine performance and service life.

NOTICE

Running the engine with insufficient oil can cause serious engine damage.

Recommended oil:SAE 10W-30 or 10W-40

Use 4-stroke motor oil that meets or exceeds the requirements for API service classification SG or SH. Always check the API SERVICE label on the oil container to be sure it includes the letters SG or SH.

NOTICE

Using nondetergent oil can shorten the engine's service life, and using 2-stroke oil can damage the engine.

Inspection

1. Position the outboard motor vertically, and remove the engine cover.
2. Remove the oil level dipstick and wipe with a clean rag.
3. Reinsert the dipstick all the way in, then pull it out and read the level. If the oil registers near or below the lower limit mark, remove the oil filler cap and fill to the upper limit mark with the recommended oil.

NOTICE

Do not overfill. Excessive oil can damage the engine.

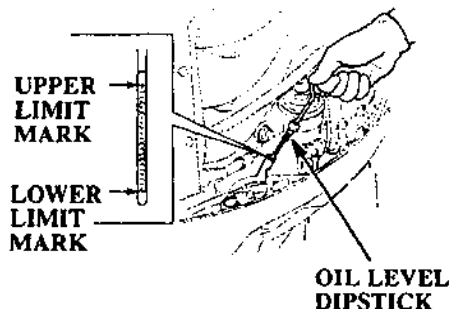

4. Reinstall the oil filler cap and tighten securely.
5. Install the engine cover and lock it securely.

If the engine oil is contaminated or discolored, replace with fresh engine oil (refer to page 93 for oil capacity, replacement interval and procedure).

4. PRE-OPERATION CHECKS

Fuel Level (optional fuel tank)

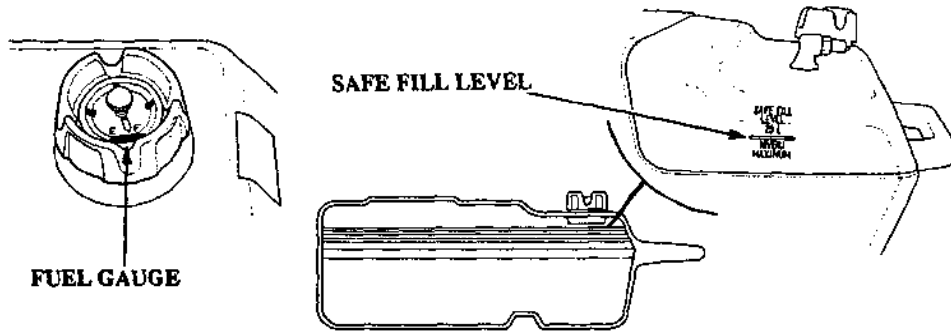

Check the fuel gauge and refill the tank to the **SAFE FILL** level mark if necessary.

Fuel tank capacity : 6.6 US gal. (25 lit)

⚠WARNING Gasoline is highly flammable and explosive. You can be burned or seriously injured when handling fuel.

- Stop engine and keep heat, sparks and flame away.
- Handle fuel only outdoors.
- Wipe up spills immediately.

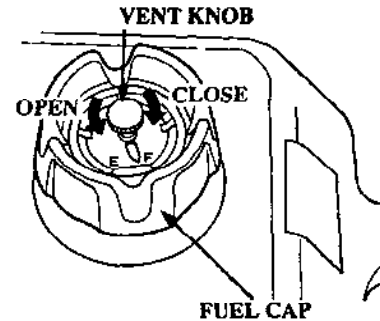

Refilling

Remove the fuel tank from the boat for refilling. Turn the vent knob counterclockwise to the open position and remove the fuel cap.

Refuel in a well-ventilated area. Fill the fuel tank up to the **SAFE FILL** level mark only. Inspect the condition of the fuel cap gasket and replace if necessary.

After refilling, install and tighten the fuel cap securely. Turn the vent knob clockwise to the closed position. Return the fuel tank to the boat.

4. PRE-OPERATION CHECKS

Fuel Recommendations

Use unleaded gasoline with a pump octane rating of 86 or higher.

These outboard motors are certified to operate on unleaded gasoline. Unleaded gasoline produces fewer engine and spark plug deposits and extends exhaust system life.

Never use stale or contaminated gasoline or an oil/gasoline mixture. Avoid getting dirt or water in the fuel tank.

Occasionally you may hear light "spark knock" or "pinging" (metallic rapping noise) while operating under heavy loads. This is no cause for concern.

If spark knock or pinging occurs at a steady engine speed, under normal load, change brands of gasoline. If spark knock or pinging persists, see an authorized Honda Marine dealer.

NOTICE

Running the engine with persistent spark knock or pinging can cause engine damage.

Running the engine with persistent spark knock or pinging is misuse, and the Distributor's Limited Warranty does not cover parts damaged by misuse.

Oxygenated Fuels

Some conventional gasolines are being blended with alcohol or an ether compound. These gasolines are collectively referred to as oxygenated fuels. To meet clean air standards, some areas of the United States and Canada use oxygenated fuels to help reduce emissions.

If you use an oxygenated fuel, be sure it is unleaded and meets the minimum octane rating requirement.

Before using an oxygenated fuel, try to confirm the fuel's contents. Some states/provinces require this information to be posted on the pump.

The following are the EPA approved percentages of oxygenates:

ETHANOL — (ethyl or grain alcohol) 10% by volume
You may use gasoline containing up to 10% ethanol by volume. Gasoline containing ethanol may be marketed under the name "Gasohol".

MTBE — (Methyl Tertiary Butyl Ether) 15% by volume
You may use gasoline containing up to 15% MTBE by volume.

METHANOL — (methyl or wood alcohol) 5% by volume
You may use gasoline containing up to 5% methanol by volume, as long as it also contains cosolvents and corrosion inhibitors to protect the fuel system. Gasoline containing more than 5% methanol by volume may cause starting and/or performance problems. It may also damage metal, rubber, and plastic parts of your fuel system.

If you notice any undesirable operating symptoms, try another service station, or switch to another brand of gasoline.

Fuel system damage or performance problems resulting from the use of an oxygenated fuel containing more than the percentages of oxygenates mentioned above are not covered under warranty.

4. PRE-OPERATION CHECKS

Propeller and cotter pin inspection

▲WARNING The propeller blades are thin and sharp. Careless handling of the propeller can result in injury. when checking the propeller:

- Remove the clip of the emergency stop switch to prevent accidental engine starting.
- Wear heavy gloves when handling the propeller.

The propeller rotates rapidly while cruising. Before starting the engine, check the propeller blades for damage and deformation and replace if necessary. We recommend carrying a spare propeller and fastening hardware aboard. If no spare propeller is available, return to the pier at low speed and replace. Consult an authorized Honda outboard motor dealer for propeller selection.

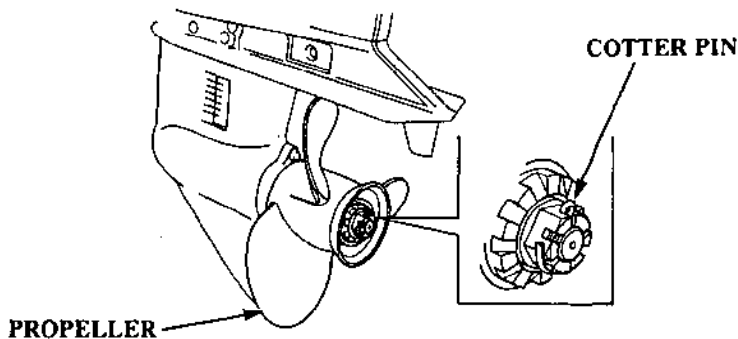

Engine speed varies according to the propeller size and the boat condition. Use of the outboard motor outside the full throttle speed range will adversely affect the engine and cause serious problems. Use of the correct propeller assures powerful acceleration, high top speed, economy and cruising comfort, and it assures longer engine life as well.

Consult with your authorized Honda outboard motor dealer for proper propeller selection.

1. Check the propeller for damage, wear, or deformation.
2. Check whether the propeller is installed properly.
3. Check the cotter pin for damage. Replace whenever the propeller is replaced.

4. PRE-OPERATION CHECKS

Control Lever Friction Adjustment

(SIDE-MOUNT TYPE)

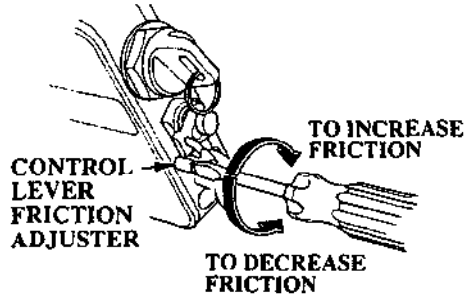

(PANEL-MOUNT TYPE)

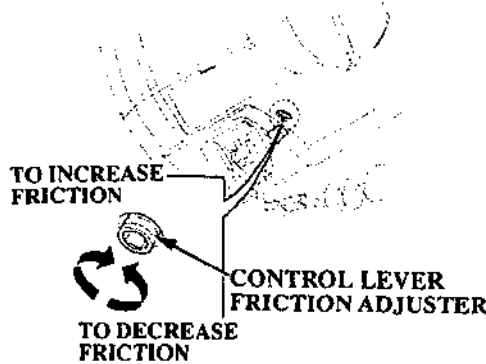

Move the control lever into forward and reverse gears, and check the amount of drag felt.

Adjust the control lever friction adjuster so that a slight amount of drag is felt. The control lever should move smoothly and freely.

(TOP-MOUNT TYPE)

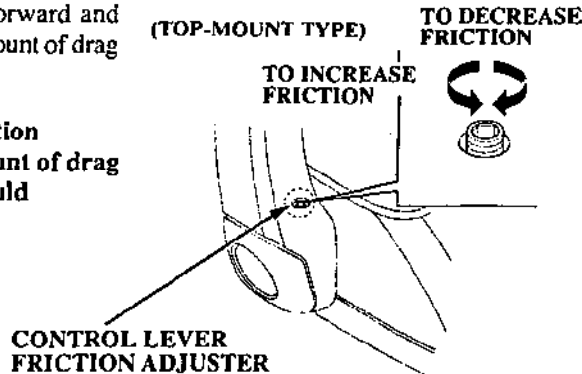

4. PRE-OPERATION CHECKS

Engine Cover Lock Lever Adjustment

If the engine cover becomes loose, it will shake and become noisy, and it may allow water to enter.

Inspect the engine cover fastening condition and adjust if necessary.

Inspection

1. Install the engine cover and fasten with the front and rear lock levers turned to LOCK position.
2. Inspect the clearance between the engine cover and the undercase at the points as shown.

The clearance should be within 0.19–0.23 in (4.8–5.8 mm).

Inspect front and rear end individually.

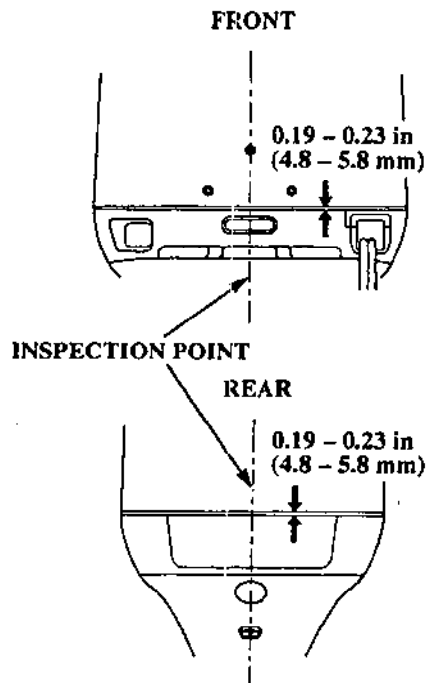

3. Adjust if the clearance is outside the specified range.

Adjustment

1. Remove the engine cover.
Loosen each hook bracket retaining bolt and adjust the height of the brackets to gain the proper clearance.
- Adjust front and rear end individually.

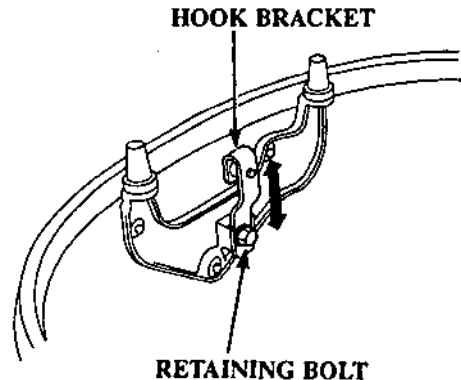

4. PRE-OPERATION CHECKS

2. After the adjustment, tighten the bolts securely and install the engine cover.

Reinspect the clearance and readjust if necessary.

Other Checks

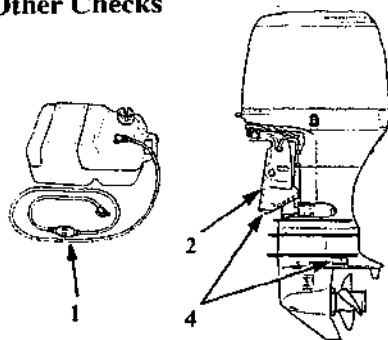

Check the following items:

1. The fuel hose for kinking, collapsing or loose connections.
2. The stern bracket for damage and mounting bolts for proper torque.
3. The tool kit contents. Compare your tool kit contents against the tool kit illustration above. Replace any missing items.
4. The anodes for damage, looseness or excessive corrosion.

The anodes help to protect the outboard motor from corrosion any time they are exposed directly to the water.

3 Tool Kit

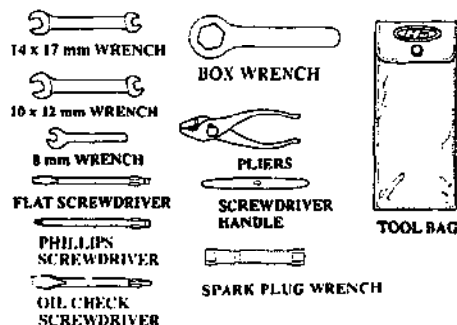

Replace anodes when they are visibly reduced in size or crumble easily.

NOTICE Painting or coating the anodes will lead to rust and corrosion damage to the outboard motor. The following materials should be kept with the boat:

1. Owner's Manual.
2. Tool Kit.
3. Spare emergency stop switch clip, engine oil, spark plugs, propeller, propeller nut, washer and cotter pin.
4. Required information regarding boating laws and regulations.

5. STARTING THE ENGINE

Optional Fuel Tank

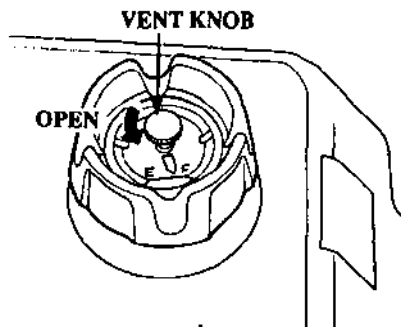

The fuel tank must be properly secured in the boat. This will protect the fuel tank from mechanical damage caused by the fuel tank shifting.

The fuel tank must be in a well ventilated area to reduce the chance of a gasoline vapor explosion. Avoid direct sunlight on the fuel tank.

To ensure that the outboard motor will be able to draw fuel from the tank, do not place the fuel tank more than 6 feet away from the motor or lower than 3 feet below the outboard end fuel hose connector.

1. Open the fuel tank vent by turning the vent knob at least 2 or 3 turns counterclockwise. Allow the air pressure inside the fuel tank to equalize with the outside air. With the vent open, air can enter the fuel tank to displace the fuel as the fuel level goes down.
2. Remove the fuel cap and inspect the condition of the fuel cap and gasket. Replace the fuel cap or gasket if they are cracked, damaged or leaking fuel.
3. Check the fuel level.

Fuel Line Connection

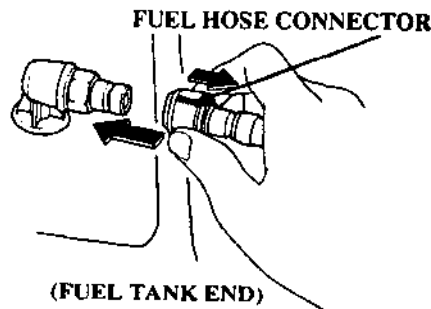

Inspect the fuel hose, and the O-ring seals in the fuel hose connectors. Replace the fuel hose, or fuel hose connectors if they are cracked, damaged or leaking fuel. Be sure the fuel hose is not kinked.

1. Connect the fuel hose connector to the fuel tank. Be sure the fuel hose connector is securely snapped in place.

5. STARTING THE ENGINE

FUEL HOSE CONNECTOR

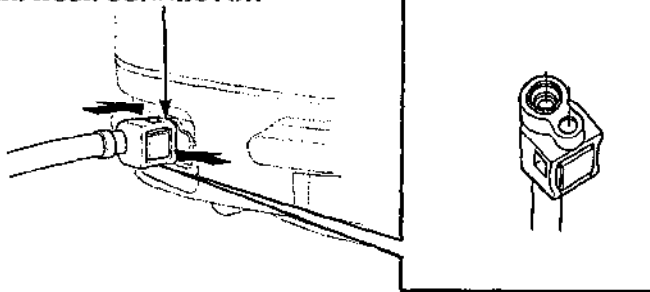

2. Connect the fuel hose connector to the outboard motor. Install the outboard end fuel hose connector with the clip toward the inside. Be sure the fuel hose connector is securely snapped in place.

NOTICE

If the outboard end fuel hose connector is forcibly installed in the reversed direction, the fuel hose connector O-ring seal can be damaged. A damaged O-ring seal can cause a fuel leak.

WARNING Gasoline is highly flammable and explosive. You can be burned or seriously injured when handling fuel.

- Stop engine and keep heat, sparks and flame away.
- Handle fuel only outdoors.
- Wipe up spills immediately.

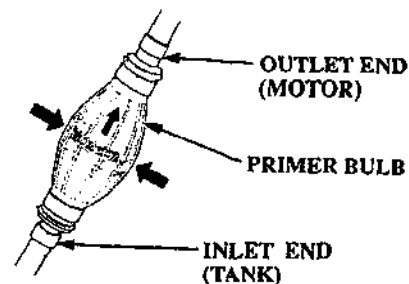

3. Hold the primer bulb so that the outlet end is higher than the inlet end. The arrow on the primer bulb points upward. Squeeze the primer bulb several times until it feels firm, indicating that fuel has reached the engine. Check for fuel leaks and repair any leaks before starting the engine.

Do not squeeze the primer bulb when the engine is running.

5. STARTING THE ENGINE (SIDE-MOUNT TYPE)

(SIDE-MOUNT TYPE)

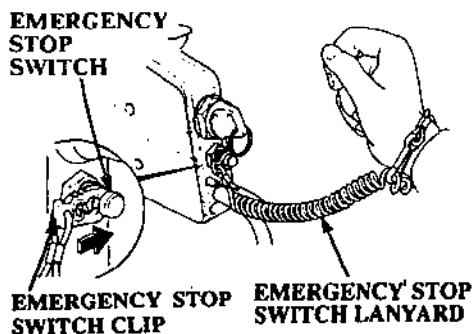

1. Engage the emergency stop switch clip (located at one end of the emergency stop switch lanyard) with the emergency stop switch.

Attach the other end of the emergency stop switch lanyard securely to the operator.

▲WARNING If the operator does not attach the emergency stop switch lanyard, and is thrown from his seat or out of the boat, the out-of-control boat can seriously injure the operator, passengers, or bystanders.

Always properly attach the lanyard before starting the engine.

The engine will not start unless the emergency stop switch clip is engaged with the emergency engine stop switch.

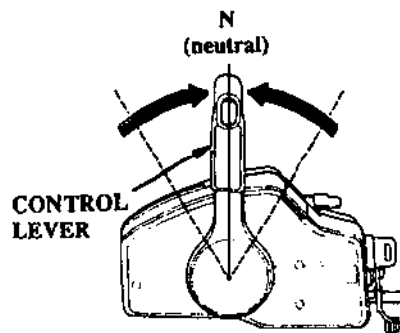

2. Move the control lever to the N (neutral) position.

The engine will not start unless the control lever is in the N (neutral) position.

5. STARTING THE ENGINE (SIDE-MOUNT TYPE)

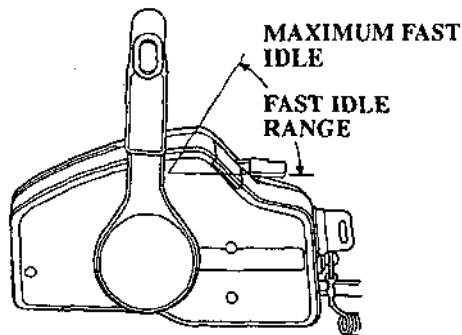

FAST IDLE LEVER

3. When the engine is cold or the ambient temperature is low, lift the fast idle lever up fully.

When the engine is warm, it may be necessary to raise the fast idle lever slightly. Hold it in this position.

The fast idle lever will not move unless the control lever is in the N (neutral) position.

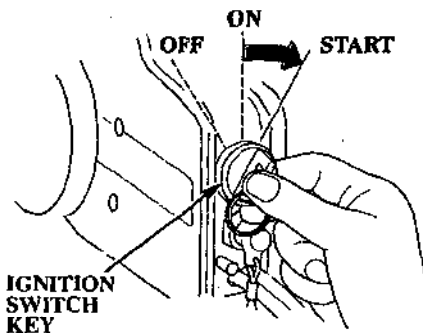

4. Holding the fast idle lever in position, turn the ignition switch key to the START position, and release the key when the engine starts.

The starter motor consumes a large amount of current. Do not run it continuously for more than 5 seconds at a time.

If the engine does not start within 5 seconds, wait at least 10 seconds before using the starter motor again.

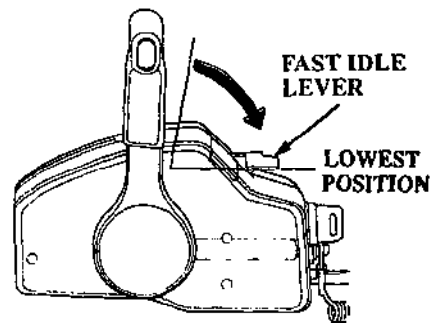

NOTICE

Do not turn the ignition switch key to the start position while the engine is running. This can damage the starter motor and flywheel.

5. After starting the engine, return the lever slowly to a position where the engine does not stall, and hold the lever in that position.

The control lever will not move unless the fast idle lever is returned to the lowest position.

5. STARTING THE ENGINE (SIDE-MOUNT TYPE)

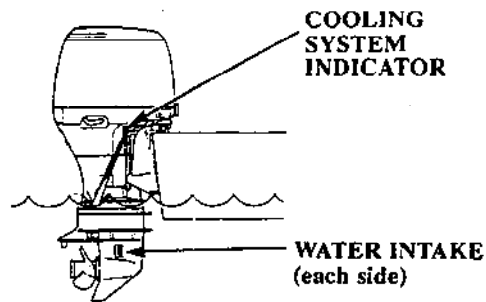

6. After the engine starts, verify water is flowing through the cooling system by monitoring the cooling system indicator. The amount of water coming out of the cooling system indicator will vary due to thermostat operation. Stop the engine if water does not come out of the cooling system indicator or if you see steam.

Check the water intake screens and the cooling system indicator discharge port, and if necessary remove any obstructions. If the problem continues, contact your closest authorized Honda Marine dealer.

NOTICE

- Running the outboard motor with an obstruction in the cooling system can damage the water pump and overheat the engine.
- The propeller must remain underwater. Running the outboard motor out of the water will damage the water pump and overheat the engine.

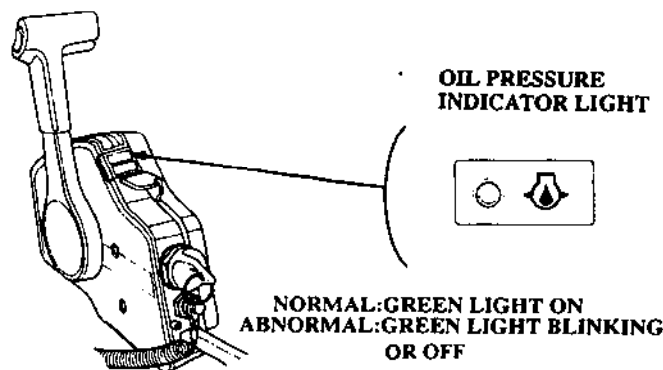

7. With the engine running, check to see if the green engine oil pressure indicator light turns ON. Stop the engine if the oil pressure indicator light does not turn ON. Check the engine oil level (see page 40). If the oil level is normal and the oil pressure indicator light does not turn ON, contact your closest authorized Honda Marine dealer.
8. Warm up the engine as follows:
Above 41°F (5°C) - run the engine for 2 or 3 minutes.
Below 41°F (5°C) - run the engine for at least 10 minutes at approximately 2,000 rpm.

Failure to completely warm up the engine will result in poor engine performance.

5. STARTING THE ENGINE (PANEL-MOUNT TYPE)

(PANEL-MOUNT TYPE)

EMERGENCY
STOP
SWITCH

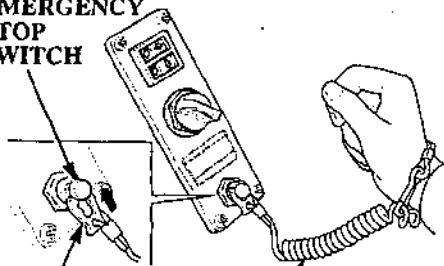

EMERGENCY STOP
SWITCH CLIP

EMERGENCY STOP
SWITCH LANYARD

1. Engage the emergency stop switch clip (located at one end of the emergency stop switch lanyard) with the emergency stop switch.

Attach the other end of the emergency stop switch lanyard securely to the operator.

⚠WARNING If the operator does not attach the emergency stop switch lanyard, and is thrown from his seat or out of the boat, the out-of-control boat can seriously injure the operator, passengers, or bystanders.

Always properly attach the lanyard before starting the engine.

The engine will not start unless the emergency stop switch clip is engaged with the emergency engine stop switch.

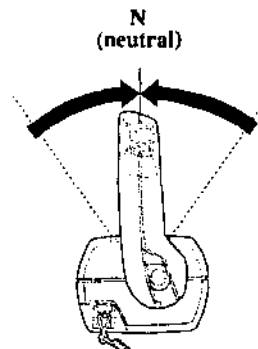

2. Move the control lever to the N (neutral) position.

The engine will not start unless the gears are not engaged.

5. STARTING THE ENGINE (PANEL-MOUNT TYPE)

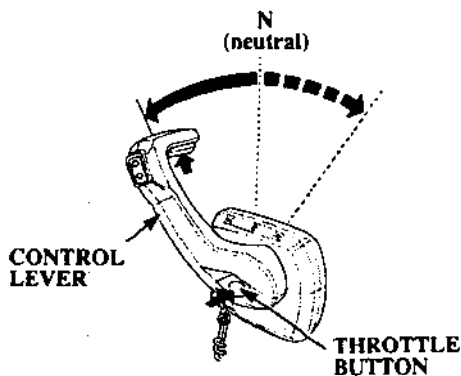

3. Push the throttle button, then move the control lever forward or backward to open the throttle slightly.

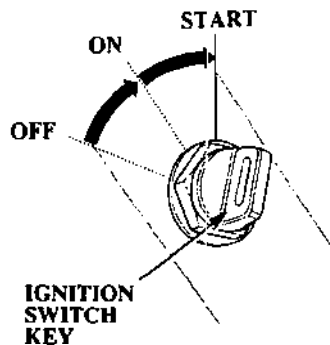

4. Turn the ignition switch key to the START position and release the key when the engine starts. The starter motor consumes a large amount of current. Do not run it continuously for more that 5 seconds at a time.

If the engine does not start within 5 seconds, wait at least 10 seconds before using the starter motor again.

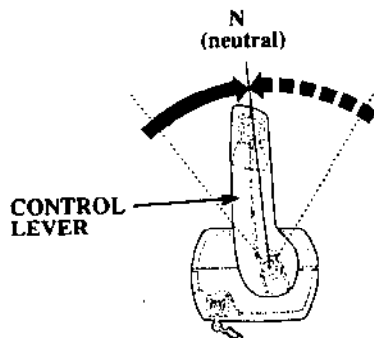

NOTICE

Do not turn the ignition switch key to the start position while the engine is running. This can damage the starter motor and flywheel.

5. After starting the engine, return the lever slowly to a position where the engine dose not stall, and hold the lever in that position.

The control lever will not shift the gears unless it is first returned to the neutral position.

5. STARTING THE ENGINE (PANEL-MOUNT TYPE)

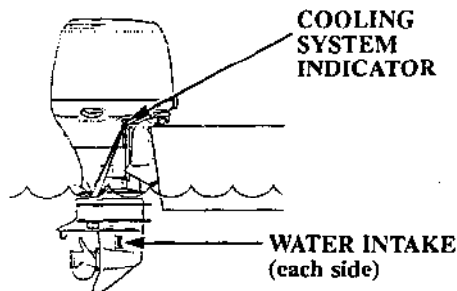

7. After the engine starts, verify water is flowing through the cooling system by monitoring the cooling system indicator. The amount of water coming out of the cooling system indicator will vary due to thermostat operation. Stop the engine if water does not come out of the cooling system indicator or if you see steam.

Check the water intake screens and the cooling system indicator discharge port, and if necessary remove any obstructions. If the problem continues, contact your closest authorized Honda Marine dealer.

NOTICE

- Running the outboard motor with an obstruction in the cooling system can damage the water pump and overheat the engine.
- The propeller must remain underwater. Running the outboard motor out of the water will damage the water pump and overheat the engine.

OIL PRESSURE
INDICATOR LIGHT

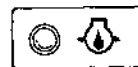

NORMAL: GREEN LIGHT ON
ABNORMAL: GREEN LIGHT BLINKING
OR OFF

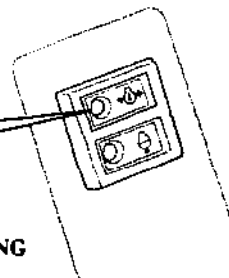

8. With the engine running, check to see if the green engine oil pressure indicator light turns ON. Stop the engine if the oil pressure indicator light does not turn ON. Check the engine oil level (see page 40). If the oil level is normal and the oil pressure indicator light does not turn ON, contact your closest authorized Honda Marine dealer.
9. Warm up the engine as follows:
Above 41°F (5°C) - run the engine for 2 or 3 minutes.
Below 41°F (5°C) - run the engine for at least 10 minutes at approximately 2,000 rpm.

Failure to completely warm up the engine will result in poor engine performance.

5. STARTING THE ENGINE (TOP-MOUNT TYPE)

(TOP-MOUNT TYPE)

EMERGENCY
STOP
SWITCH

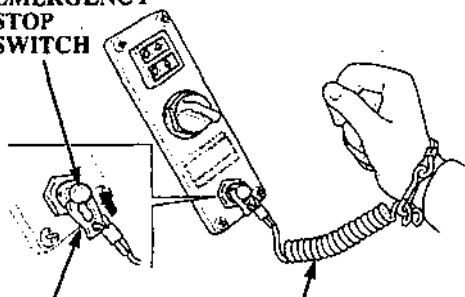

EMERGENCY STOP SWITCH LANYARD EMERGENCY STOP SWITCH CLIP

NOTICE The propeller must remain underwater. Running the outboard motor out of the water will damage the water pump and overheat the engine.

The following procedure is for starting a single engine equipped with a top-mount control.

For dual engines equipped with top-mount controls, follow the same steps for each engine.

1. Engage the emergency stop switch clip (located at one end of the emergency stop switch lanyard) with the emergency stop switch.

Attach the other end of the emergency stop switch lanyard securely to the operator.

WARNING If the operator does not attach the emergency stop switch lanyard, and is thrown from his seat or out of the boat, the out-of-control boat can seriously injure the operator, passengers, or bystanders.

Always properly attach the lanyard before starting the engine.

The engine will not start unless the emergency stop switch clip is engaged with the emergency engine stop switch.

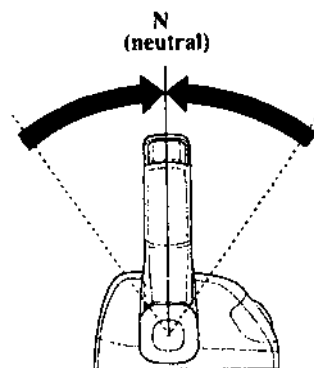

2. Move the control lever to the N (neutral) position.

The engine will not start unless it is in neutral.

5. STARTING THE ENGINE (TOP-MOUNT TYPE)

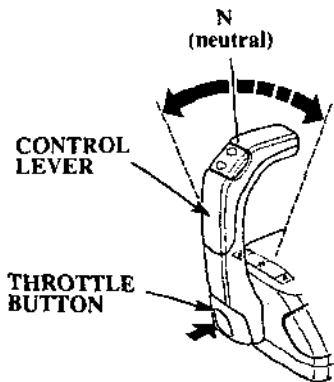

3. Push the throttle button, then move the control lever (s) forward or backward to open the throttle slightly.

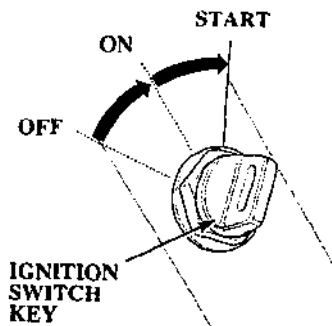

4. Turn the ignition switch key to the START position and release the key when the engine starts. The starter motor consumes a large amount of current. Do not run it continuously for more than 5 seconds at a time.

If the engine does not start within 5 seconds wait at least 10 seconds before using the starter motor again.

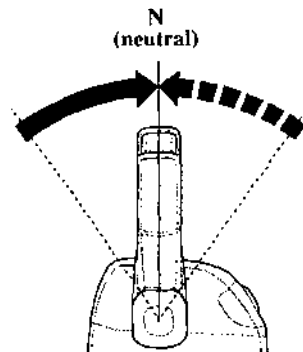

- NOTICE**
Do not turn the ignition switch key to the start position while the engine is running. This can damage the starter motor and flywheel.
5. After starting the engine, return the lever slowly to a position where the engine does not stall, and hold the lever in that position.

The control lever will not shift gears unless it is first returned to the neutral position.

5. STARTING THE ENGINE (TOP-MOUNT TYPE)

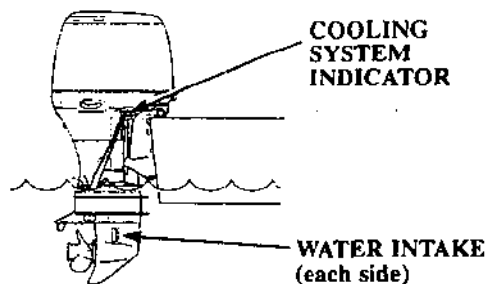

7. After the engine starts, verify water is flowing through the cooling system by monitoring the cooling system indicator. The amount of water coming out of the cooling system indicator will vary due to thermostat operation. Stop the engine if water does not come out of the cooling system indicator or if you see steam.

Check the water intake screens and the cooling system indicator discharge port, and if necessary remove any obstructions. If the problem continues, contact your closest authorized Honda Marine dealer.

NOTICE

- Running the outboard motor with an obstruction in the cooling system can damage the water pump and overheat the engine.
- The propeller must remain underwater. Running the outboard motor out of the water will damage the water pump and overheat the engine.

OIL PRESSURE INDICATOR LIGHT

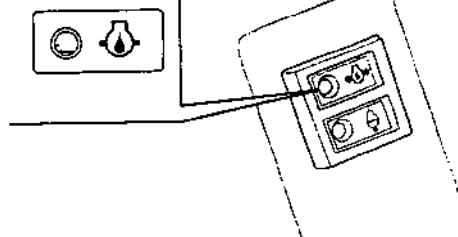

NORMAL: GREEN LIGHT ON
ABNORMAL: GREEN LIGHT BLINKING OR OFF

8. With the engine running, check to see if the green engine oil pressure indicator light turns ON. Stop the engine if the oil pressure indicator light does not turn ON. Check the engine oil level (see page 40). If the oil level is normal and the oil pressure indicator light does not turn ON, contact your closest authorized Honda Marine dealer.
9. Warm up the engine as follows:
Above 41°F (5°C) - run the engine for 2 or 3 minutes.
Below 41°F (5°C) - run the engine for at least 10 minutes at approximately 2,000 rpm.

Failure to completely warm up the engine will result in poor engine performance.

5. STARTING THE ENGINE (TROUBLESHOOTING)

Troubleshooting Starting Problems

SYMPTOM	POSSIBLE CAUSE	REMEDY
Starter motor doesn't turn over.	<ol style="list-style-type: none">1. Shift lever not in neutral position.2. Blown fuse.3. Weak battery.4. Faulty battery connections	<ol style="list-style-type: none">1. Set shift lever in neutral position.2. Replace fuse. (refer to pages 106 and 107)3. Charge battery.4. Clean and/or tighten battery connections.
Starter motor turns over but engine will not start.	<ol style="list-style-type: none">1. Emergency stop switch clip is not engaged.2. Out of fuel.3. Vent knob not open.4. Primer bulb has not been squeezed.5. Engine flooded.	<ol style="list-style-type: none">1. Engage the emergency stop switch clip. (refer to pages 16, 22 and 28)2. Supply fuel. (refer to page 41)3. Open vent knob. (refer to page 48)4. Squeeze primer bulb to supply fuel. (refer to page 49)5. Clean and dry spark plugs. (refer to page 99)

6. OPERATION

Break-in Procedure

Break-in period 10 hours

Break-in operation allows the moving parts to wear-in evenly and thus ensures proper performance and longer outboard motor life.

Break-in your new outboard motor as follows:

First 15 minutes:

Run the engine at trolling speed.

Use the minimum amount of throttle opening necessary to operate the boat at a safe trolling speed.

Next 45 minutes:

Run the engine up to a maximum of 2,000 to 3,000 rpm or 10% to 30% throttle opening.

Next 60 minutes:

Run the engine up to maximum of 4,000 to 5,000 rpm or 50% to 80% throttle opening. Short bursts

of full throttle are acceptable, but do not operate the engine continuously at full throttle.

Next 8 hours:

Avoid continuous full throttle operation (100% throttle opening). Do not run the engine at full throttle for more than 5 minutes at a time.

For boats that plane easily, bring the boat up on plane, then reduce the throttle opening to the specified break-in settings called out above.

6. OPERATION (SIDE-MOUNT TYPE)

(SIDE-MOUNT TYPE)

Gear Shifting

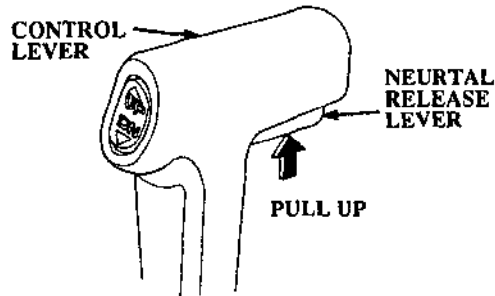

While pulling up the neutral release lever, move the control lever approximately 30° toward F (forward) or toward R (reverse) to engage the desired gear.

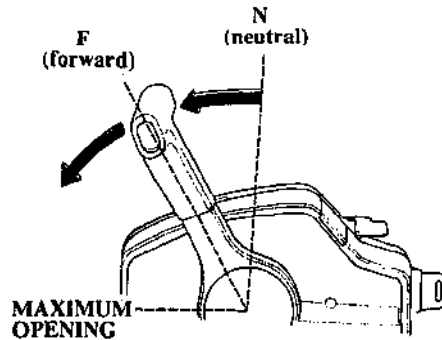

Moving the control lever farther forward or backward than 30° will increase throttle opening and boat speed.

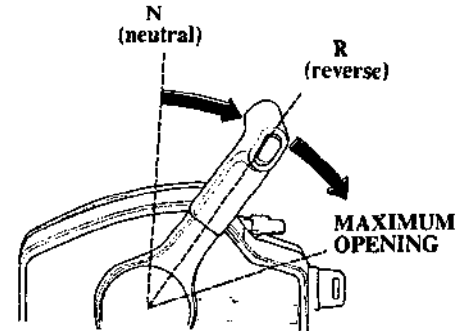

The control lever will not move unless the neutral release lever is pulled up, and the fast idle lever is in the lowest position.

6. OPERATION (SIDE-MOUNT TYPE)

Cruising

POWER TRIM/TILT SWITCH

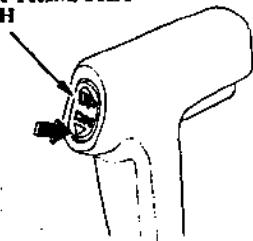

1. Press the DN portion of the power trim/tilt switch to tilt the motor to the lowest position.

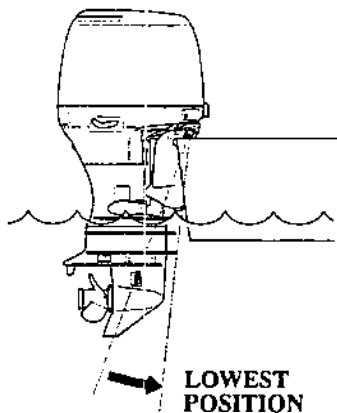

2. Move the control lever approximately 30° from N (neutral) toward F (forward) to engage the F (forward) gear.

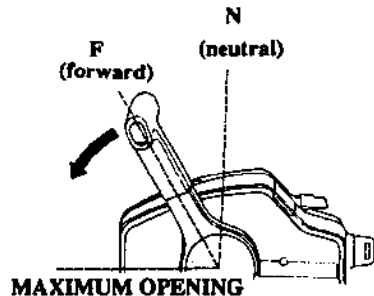

3. For optimum fuel economy, limit throttle opening to 80%.
Moving the control lever farther than 30° will increase the throttle opening and boat speed.
When cruising at high speed in rough water conditions or large waves, the propeller may not remain fully in the water, and the engine speed could exceed the maximum speed range. Slow down to keep the propeller in the water.

6. OPERATION (PANEL-MOUNT TYPE)

(PANEL-MOUNT TYPE)

Gear Shifting

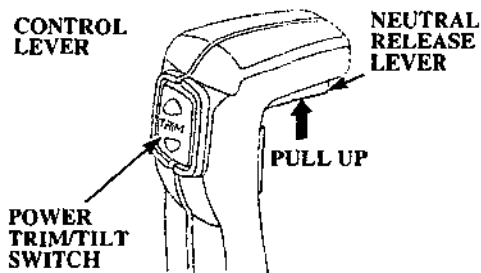

NOTICE

Avoid sharp and abrupt operation of the control lever. Operate it moderately. Operate the control lever and raise the engine speed after making sure that the gear was shifted securely.

While pulling up the neutral release lever, move the control lever approximately 35° toward F (forward) or toward R (reverse) to engage the desired gear.

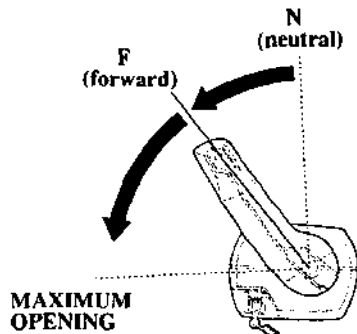

Moving the control lever farther forward than 35° will increase throttle opening and boat speed.

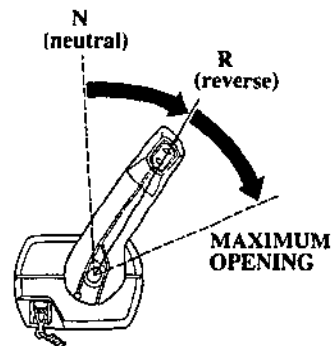

The control lever will not move unless the neutral release lever is pulled up.

6. OPERATION (PANEL-MOUNT TYPE)

Cruising

POWER TRIM/TILT SWITCH

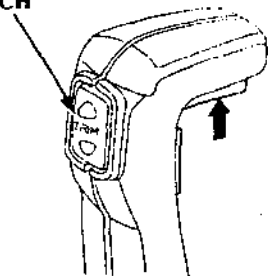

1. Press the DN portion of the power trim/tilt switch to tilt the motor to the lowest position.

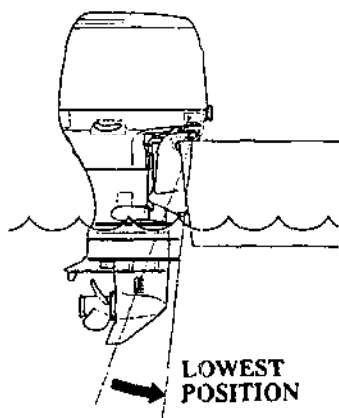

2. Move the control lever approximately 35° from N (neutral) toward F (forward) to engage the F (forward) gear.

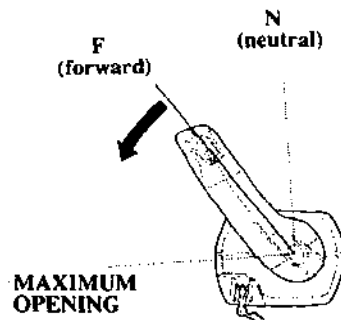

Moving the control lever farther than 35° will increase the throttle opening and boat speed.

3. For optimum fuel economy, limit throttle opening to 80%.

When cruising at high speed in rough water conditions or large waves, the propeller may not remain fully in the water, and the engine speed could exceed the maximum speed range. Slow down to keep the propeller in the water.

6. OPERATION (TOP-MOUNT TYPE)

(TOP-MOUNT TYPE) Gear Shifting

SINGLE TYPE

CONTROL
LEVER

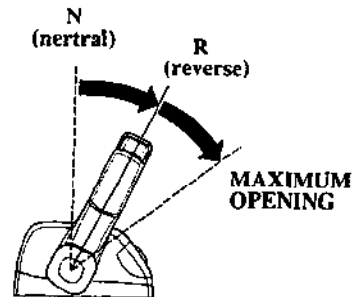
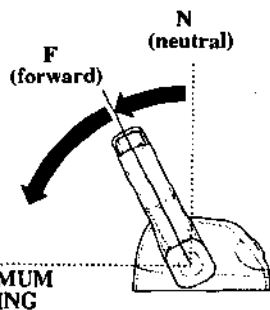
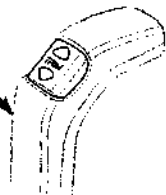

DUAL TYPE

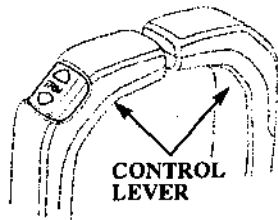

Move the control lever approximately 35° toward F (forward) or toward R (reverse) to engage the desired gear.

NOTICE

Avoid sharp and abrupt operation of the control lever. Operate it moderately. Operate the control lever and raise the engine speed after making sure that the gear was shifted securely.

Moving the control lever farther forward or backward than 35° will increase throttle opening and boat speed.

The control lever will not move unless the neutral release lever is pulled up.

6. OPERATION (TOP-MOUNT TYPE)

Cruising

SINGLE TYPE

POWER
TRIM/TILT
SWITCH

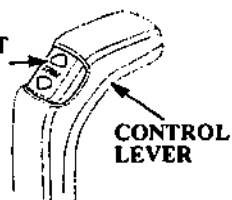

LEFT MOTOR
TRIM/TILT SWITCH

RIGHT MOTOR
TRIM/TILT SWITCH

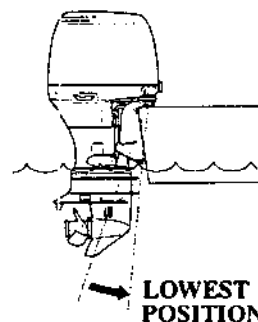
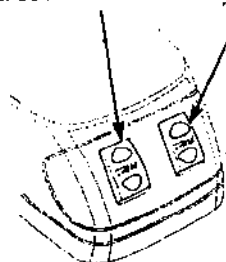

DUAL TYPE

POWER
TRIM/TILT
SWITCH

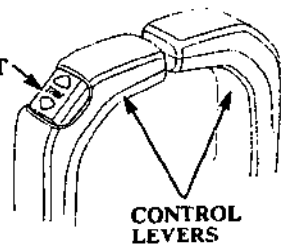

1. Press the DN portion of the power trim/tilt switch to tilt the motor to the lowest position.

If your boat is dual outboard motor type, adjust the trim angle of the right and left motors to be equal using the switches on the control box, as necessary.

2. Move the control lever approximately 35° from N (neutral) toward F (forward) to engage the F (forward) gear.

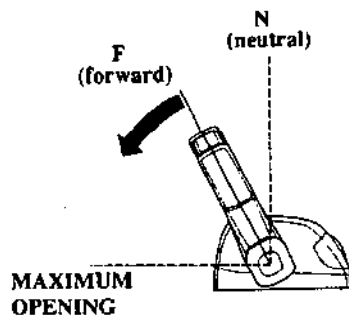

Moving the control lever farther than 35° will increase the throttle opening and boat speed.

3. For optimum fuel economy, limit throttle opening to 80%.

When cruising at high speed in rough water conditions or large waves, the propeller may not remain fully in the water, and the engine speed could exceed the maximum speed range. Slow down to keep the propeller in the water.

6. OPERATION (POWER TRIM/TILT)

Power Trim/Tilt System

The power trim/tilt system can adjust the motor angle while cruising, or the motor tilt angle while mooring. Motor trim angle adjustment is necessary to compensate for boat load or weight distribution, water conditions, propeller or engine condition.

The motor trim angle can be adjusted while accelerating or cruising to obtain the maximum boat speed, optimum boat stability, and fuel economy.

Under normal conditions, the boat will achieve optimum boat performance when the engine is running at maximum rpm and the ventilation plate is level with the water.

Press either the UP or DN portion of the power trim/tilt switch, and trim the motor to the best position for the cruising conditions.

The power trim/tilt system operates when the switch is pressed, and it stops when the switch is released.

(SIDE-MOUNT TYPE)

POWER TRIM/TILT SWITCH

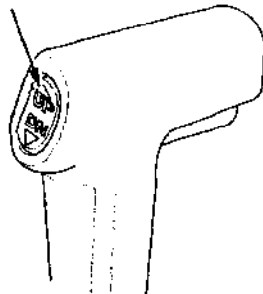

(PANEL-MOUNT TYPE)

POWER TRIM/TILT SWITCH

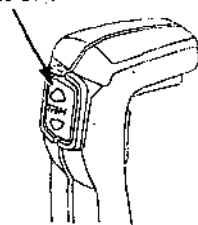

(TOP-MOUNT TYPE)

SINGLE TYPE

POWER TRIM/TILT SWITCH

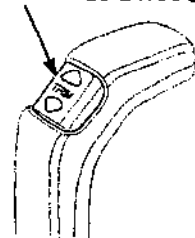

DUAL TYPE

POWER TRIM/TILT SWITCH

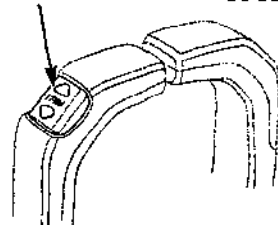

6. OPERATION (POWER TRIM/TILT)

NOTICE

Excessive trim/tilt angle during operation can cause the propeller to raise out of the water and cause propeller ventilation and engine over-revving. Excessive trim/tilt angle can also damage the water pump and overheat the engine.

To trim motor up slightly, press the UP portion momentarily.

To trim motor down slightly, press the DN portion momentarily.

Decrease the trim angle on high speed turns to reduce the possibility of propeller ventilation.

Improper motor trim angle can result in an unstable steering condition.

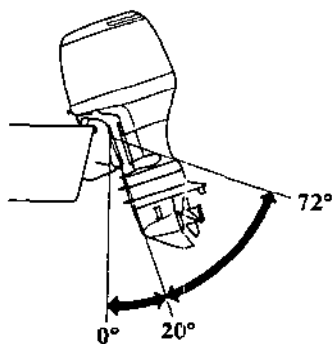

TRIM ANGLE

Dual-Mount Type Power Trim/Tilt Switchs

LEFT INDIVIDUAL ADJUSTMENT

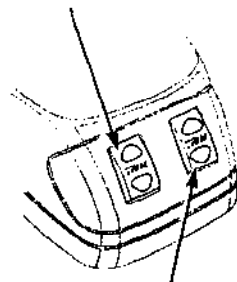

RIGHT INDIVIDUAL ADJUSTMENT

The right and left outboard motors can be adjusted separately with the individual adjustment switch on the console side.

6. OPERATION (POWER TRIM/TILT)

MOTOR TRIMMED TOO LOW

MOTOR TRIMMED TOO HIGH

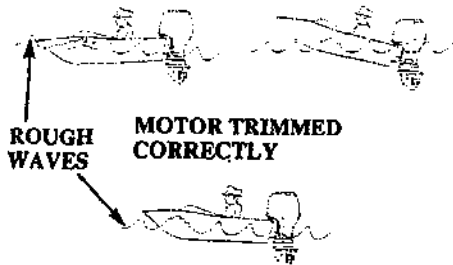

When cruising:

- (A) Into a high wind, trim the motor down slightly to level the bow and improve boat stability.
- (B) With a tail wind, trim the motor up slightly to raise the bow and improve boat stability.
- (C) Through rough waves, do not trim the motor too low or too high to avoid an unstable steering condition.

Trim Meter

The trim meter indicates the trim angle of the motor. Refer to the trim meter, and press the UP or DN portion of the power trim/tilt switch to adjust the motor trim angle to achieve good boat performance and stability.

BOW TOO LOW DUE TO
1. LOAD IN THE FRONT
2. MOTOR TRIMMED TOO LOW

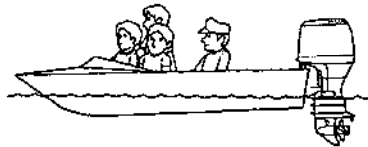

BOW TOO HIGH DUE TO
1. LOAD IN THE REAR
2. MOTOR TRIMMED TOO HIGH

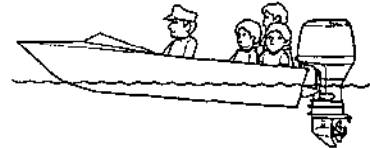

With the motor trimmed low, the trim meter will read as shown. To raise the bow, increase the motor trim angle by pressing the UP portion of the power trim/tilt switch.



With the motor trimmed high, the trim meter will read as shown. To lower the bow, decrease the motor trim angle by pressing the DN portion of the power trim/tilt switch.

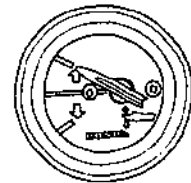

6. OPERATION (POWER TRIM/TILT)

Power Tilt Switch (Engine Pan)

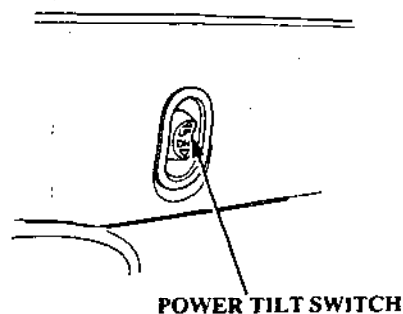

The power tilt switch located on the engine pan is a convenience switch for tilting the motor for trailering, or performing outboard motor maintenance. This power tilt switch should only be operated when the boat is stopped and the engine is off.

Manual Relief Valve

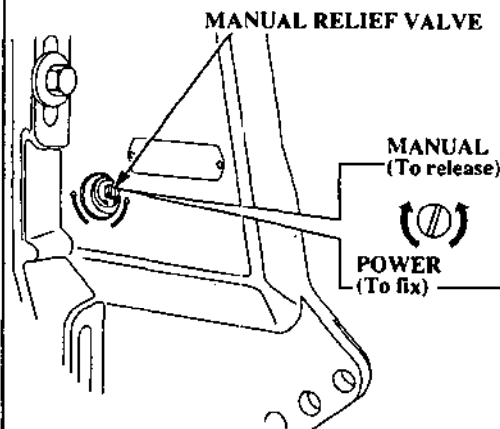

If the power trim/tilt switch will not tilt the outboard motor, the motor can be manually tilted up or down by operating the manual relief valve. To tilt the outboard motor manually, turn the manual relief valve under the left stern bracket no more than 1 or 2 turns counterclockwise, using a screwdriver.

After tilting the motor, turn the manual relief valve clockwise securely. The manual relief valve must be tightened securely before operating the motor, or the motor could tilt up when operating in reverse.

6. OPERATION (POWER TRIM/TILT)

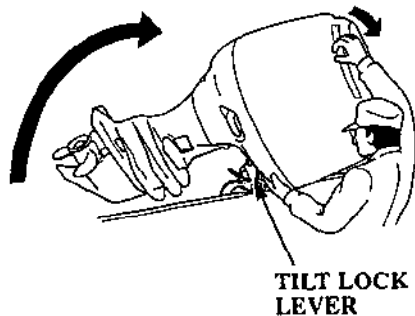

Tilt Lock Lever

Use the tilt lock lever when the boat is moored.

1. Tilt the motor up as far as it will go using the power trim/tilt switch.
2. Move the tilt lock lever to the LOCK position, and lower the outboard motor until the lock lever contacts the stern bracket (refer to page 34).

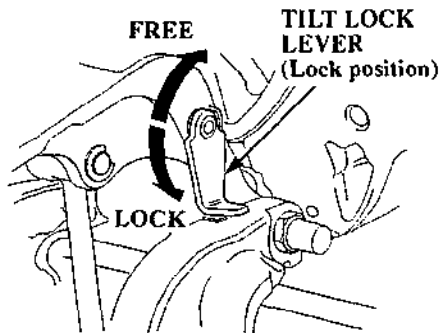

It may be necessary to lift the engine cover grip slightly to swing the tilt lock lever into the LOCK position.

3. To lower the motor, tilt the motor up slightly, move the tilt lock lever to the FREE position, and lower the motor to the desired position.

6. OPERATION

Trim Tab Adjustment

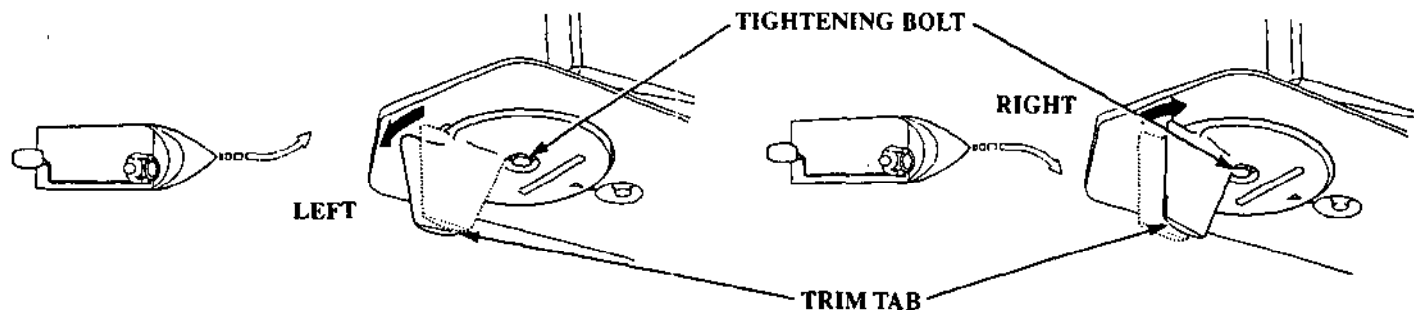

The trim tab is provided to adjust for "torque steer" which is a reaction of the propeller rotation or propeller torque. If during a high speed turn, an unequal amount of effort is required to turn the boat right or left, adjust the trim tab so that an equal amount of effort is required.

Distribute the load evenly in the boat, and run the boat in a straight course at full throttle. Slightly turn the steering wheel for both right and left turns to determine the amount of effort required.

If less effort is required to make left turns:
Loosen the trim tab tightening bolt, and turn the rear end of the trim tab toward the left. Tighten the bolt securely.

If less effort is required to make right turns:
Loosen the trim tab tightening bolt, and turn the rear end of the trim tab toward the right. Tighten the bolt securely.

Make small adjustments at a time and retest. Incorrect trim tab adjustment can cause adverse steering.

6. OPERATION (MOTOR PROTECTION SYSTEM)

Engine Oil Pressure, Overheat, PGM-FI, ACG Indicator Systems

If the engine oil pressure drops and/or the engine overheats, either or both indicator systems could be activated. When activated, the engine speed will decrease gradually, the green oil pressure indicator light may turn OFF, and the red overheat indicator light may turn ON (see page 74). A continuous buzzer will sound.

The engine speed can not be increased with a larger throttle opening until the malfunction is corrected. When the malfunction is corrected, the engine speed will increase gradually.

Each of the PGM-FI, ACG, oil pressure, and overheat indicator systems is activated as described in the following table.

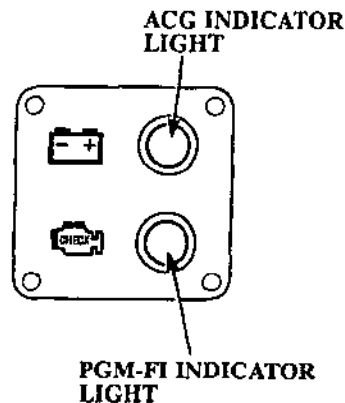
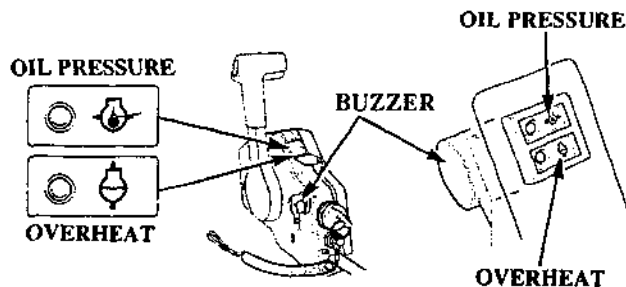

6. OPERATION (MOTOR PROTECTION SYSTEM)

System Symptom	INDICATOR LIGHTS				BUZZER
	OIL PRESSURE (Green)	OVERHEAT (Red)	ACG (Red)	PGM-FI (Red)	CORRESPONDING SYSTEM
At starting	ON (2 sec)	ON (2 sec)	ON	ON (2 sec)	With the engine key turned on: ON (2 times)
During operation	ON	OFF	OFF	OFF	OFF
Low oil pressure	OFF	OFF	OFF	OFF	ON (continuously)
Overheat	ON	ON	OFF	OFF	ON (continuously)
Low oil pressure & overheat	OFF	ON	OFF	OFF	ON (continuously)
ACG	ON	OFF	ON	OFF	ON (intermittently)
PGM-FI	ON	OFF	OFF	ON	ON (intermittently)
Low oil pressure & ACG	OFF	OFF	ON	OFF	ON (continuously)
Overheat & ACG	ON	ON	ON	OFF	ON (continuously)
PGM-FI & ACG	ON	OFF	ON	ON	ON (intermittently)
Low oil pressure & PGM-FI	OFF	OFF	OFF	ON	ON (continuously)
Overheat & PGM-FI	ON	ON	OFF	ON	ON (continuously)

6. OPERATION (MOTOR PROTECTION SYSTEM)

When the oil pressure warning systems is activated:

1. Stop the engine immediately and check the engine oil level (refer to page 40).
2. If the oil is up to the recommended level, restart the engine. If the oil pressure indicator system stops after 30 seconds, the system is normal.

If the throttle was closed suddenly after cruising at full throttle, the engine speed may drop below the specified idle speed. This could cause the oil pressure indicator system to activate momentarily.

3. If the oil pressure indicator system stays activated after 30 seconds, return to the closest boat landing, and contact your closest authorized Honda Marine dealer.

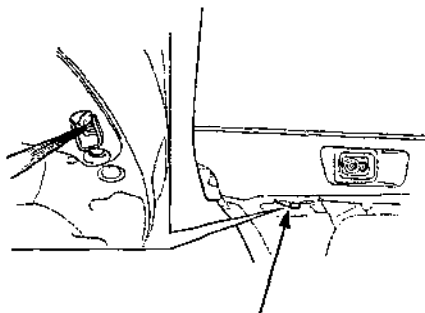

COOLING SYSTEM INDICATOR

When the overheat indicator system is activated:

1. Return the gearshift lever or control lever to the N (neutral) position immediately. Check to see if water is flowing out of the cooling system indicator.
2. If water is flowing out of the cooling system indicator, continue idling for 30 seconds. If the overheat indicator system stops after 30 seconds, the system is normal.

If the engine is turned off after running at full throttle, the engine temperature may rise above normal. If the engine is restated, shortly after being turned off, the overheat indicator system could be activated momentarily.

3. If the overheat indicator system stays activated, stop the engine, tilt up the motor and check the water intakes for obstructions. If there are no obstructions at the water intakes, return to the closest boat landing, and contact your closest authorized Honda Marine dealer.

6. OPERATION (MOTOR PROTECTION SYSTEM)

When the PGM-FI indicator system is activated.

1. Consult with an authorized Honda outboard motor dealer.

When the ACG indicator system is activated.

1. Check the battery.
If the battery is OK, consult with an authorized Honda outboard motor dealer.

Overrev Limiter

This outboard motor is equipped with an engine overrev limiter which activates when the engine speed increases excessively. The overrev limiter can be activated while cruising, tilting up the motor, or when ventilation occurs during a sharp turn.

When the overrev limiter is activated:

1. Reduce the throttle opening immediately and check the trim angle.
2. If the trim angle is correct but the overrev limiter stays activated, stop the engine, check the condition of the outboard motor, and check the propeller for damage. Correct or service as necessary.

Anodes

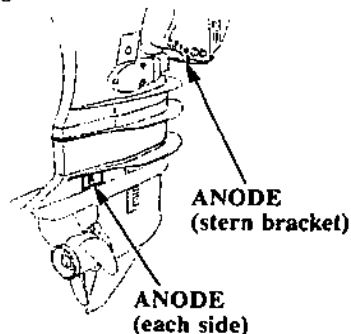

The anodes are a sacrificial material which helps to protect the outboard motor from corrosion.

NOTICE Painting or coating the anodes will lead to rust and corrosion damage to the outboard motor.

There are also 2 small sacrificial anodes in the water passages of the engine block.

Shallow Water Operation

NOTICE

Excessive trim/tilt angle during operation can cause the propeller to raise out of the water and cause propeller ventilation and engine over revving. Excessive trim/tilt angle can also damage the water pump and overheat the engine.

When operating in shallow water, tilt the motor up to prevent the propeller and gear case from hitting the bottom. With the motor tilted up, operate the engine at low speed.

Monitor the cooling system indicator for water discharge. Be sure that the motor is not tilted so high that the water intakes are out of the water.

7. STOPPING THE ENGINE (SIDE-MOUNT TYPE)

(SIDE-MOUNT TYPE) Emergency Engine Stop

EMERGENCY
STOP SWITCH

EMERGENCY STOP
SWITCH LANYARD

PULL

EMERGENCY STOP SWITCH CLIP

Disengage the emergency stop switch clip from the emergency stop switch by pulling the emergency stop switch lanyard.

It is a good idea to stop the engine with the emergency stop switch lanyard from time to time to be sure that the switch is operating properly.

Normal Engine Stop

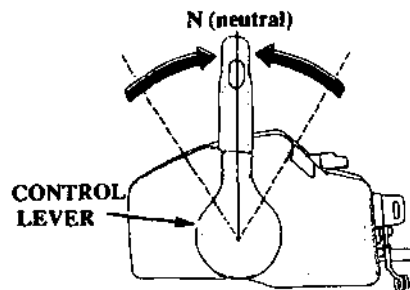

1. Move the control lever to the N (neutral) position, and turn the ignition key to the OFF position.

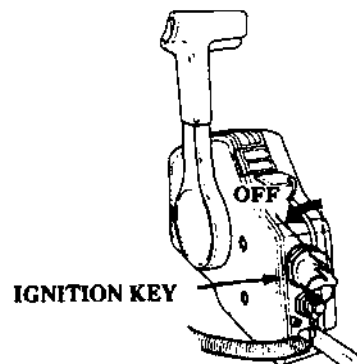

2. When the boat is not in use, remove and store the ignition key.

7. STOPPING THE ENGINE (PANEL-MOUNT TYPE)

(PANEL-MOUNT TYPE)

Emergency Engine Stop

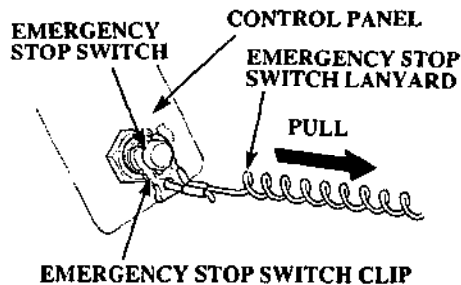

Disengage the emergency stop switch clip from the emergency stop switch by pulling the emergency stop switch lanyard.

It is a good idea to stop the engine with the emergency stop switch lanyard from time to time to be sure that the switch is operating properly.

Normal Engine Stop

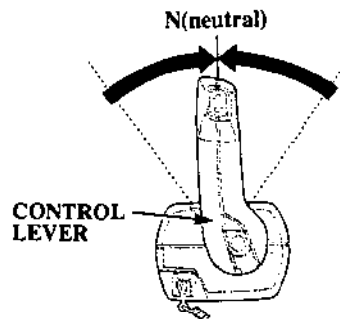

1. Move the control lever to the N (neutral) position, and turn the ignition key to the OFF position.

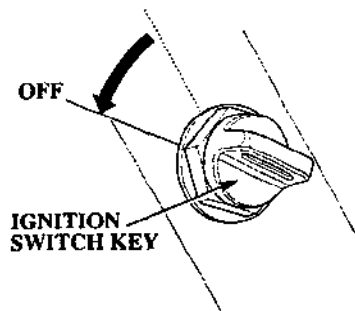

2. When the boat is not in use, remove and store the ignition key.

7. STOPPING THE ENGINE (TOP-MOUNT TYPE)

(TOP-MOUNT TYPE)

Emergency Engine Stop

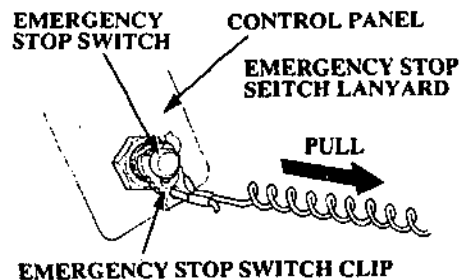

Disengage the emergency stop switch clip(s) from the emergency stop switch(es) by pulling the emergency stop switch lanyard(s).

It is a good idea to stop the engine(s) with the emergency stop switch lanyard(s) from time to time to be sure that the switch(es) is(are) operating properly.

Normal Engine Stop

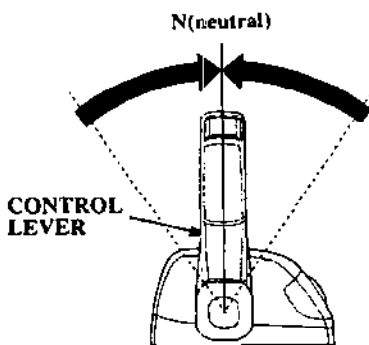

1. (SINGLE TOP-MOUNT TYPE)
Move the control lever to the N (neutral) position, and turn the ignition key to the OFF position.

(DUAL TOP-MOUNT TYPE)
Move both control levers simultaneously to the N (neutral) position, and turn each ignition key to the OFF position.

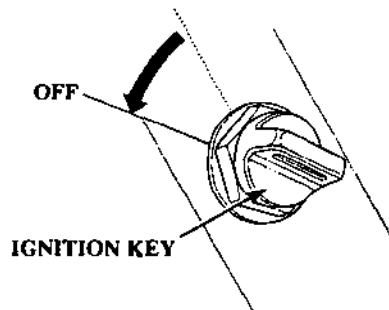

2. When the boat is not in use, remove and store the ignition switch key(s).

Before transporting the outboard motor, close the fuel cap vent knob (refer to page 37) and disconnect the fuel coupling from the outboard motor (refer to page 49).

Trailer

When trailering or transporting the boat with the motor attached, it is recommended that the motor remain in the normal run position.

Use a motor support bar (refer to your motor support bar manufacturer's instructions) to stop the motor's side-to-side movement.

If there is insufficient road clearance with the motor in the normal run position, then trailer the motor in the tilted position using a motor support bar (refer to your motor support bar manufacturer's instructions) or remove the motor from the boat.

8. TRANSPORTING

Transporting on a vehicle

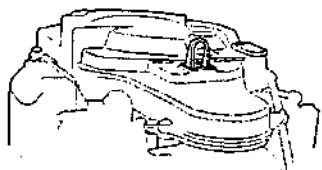

When transporting the outboard motor on a vehicle, perform following.

1. Remove the engine cover.

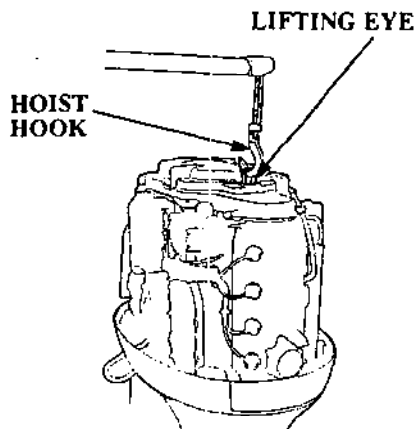

2. Hook a hoist hook to the lifting-eye, and lift the motor from the boat.

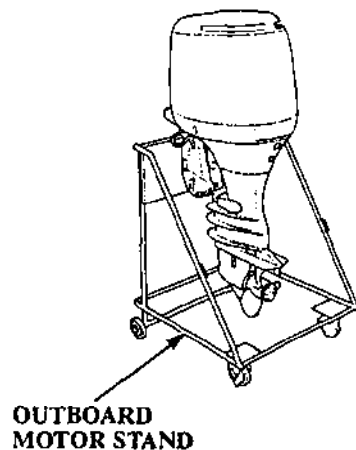

3. Place the motor on an outboard motor stand and secure with bolts and nuts.
4. Reinstall the engine cover.

Horizontal Transport

Before removing the motor from the boat, drain the vapor separator and engine oil. Follow the vapor separator drain procedure on page 111.

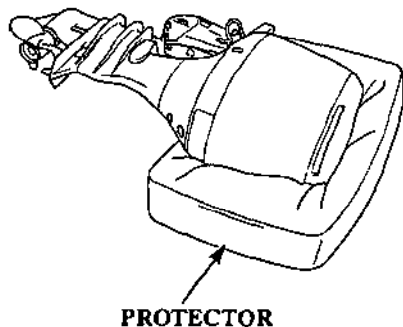

Always rest the motor on protectors and be sure to protect, it from impact and damage.

9. CLEANING AND FLUSHING

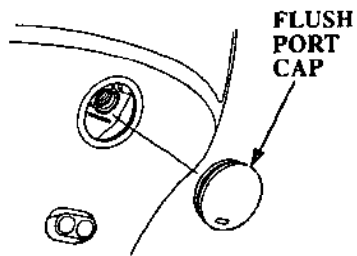

Thoroughly clean and flush the outboard motor with fresh water after operation in dirty or salty water.

Flushing with the water hose adapter (optional equipment)

Do not run the engine during this flushing procedure. For safety, remove the emergency stop switch clip, so the engine cannot be started while you are standing near the propeller.

1. Remove the flush port cap.

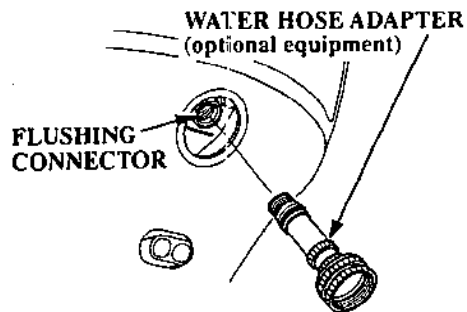

2. Install the water hose adapter (optional equipment) in the flushing connector.

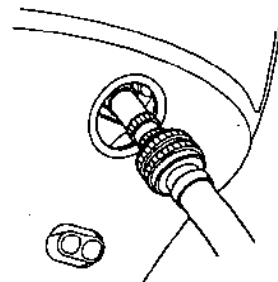

3. Connect a water hose to the water hose adapter (optional equipment), and turn on the water supply.

9. CLEANING AND FLUSHING

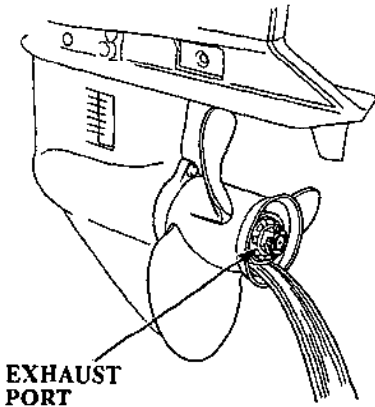

4. Make sure that the water comes out from the exhaust port.
5. After flushing, remove the water hose adapter (optional equipment) and reinstall the hose flush port cap.

10. MAINTENANCE

THE IMPORTANCE OF MAINTENANCE

Good maintenance is essential for safe, economical, and trouble-free operation. It will also help reduce pollution.

⚠WARNING Improperly maintaining this outboard motor, or failure to correct a problem before operation, can cause a malfunction in which you can be seriously hurt or killed.

Always follow the inspection and maintenance recommendations and schedules in this owner's manual.

To help you properly care for your outboard motor, the following pages include a maintenance schedule, routine inspection procedures, and simple maintenance procedures using basic hand tools. Other service tasks that are more difficult, or require special tools, are best handled by

professionals and are normally performed by a Honda technician or other qualified mechanic.

The maintenance schedule applies to normal operating conditions. If you operate your outboard motor under unusual conditions, consult your servicing dealer for recommendations applicable to your individual needs and use.

Remember that your authorized Honda marine dealer knows your outboard motor best and is fully equipped to maintain and repair it.

To ensure the best quality and reliability, use only new, genuine Honda parts or their equivalents for repair and replacement.

Maintenance, replacement, or repair of the emission control devices and systems may be performed by any marine engine repair establishment or individual, using parts that are "certified" to EPA standards.

MAINTENANCE SAFETY

Some of the most important safety precautions follow. However, we cannot warn you of every conceivable hazard that can arise in performing maintenance. Only you can decide whether or not you should perform a given task.

⚠WARNING Failure to properly follow maintenance instructions and precautions can cause you to be seriously hurt or killed.

Always follow the procedures and precautions in this owner's manual.

Safety Precautions

- Make sure the engine is off before you begin any maintenance or repairs. This will eliminate several potential hazards:
 - Carbon monoxide poisoning from engine exhaust.
Be sure there is adequate ventilation whenever you operate the engine.
 - Burns from hot parts.
Let the engine cool before touching.
 - Injury from moving parts.
Do not run the engine unless instructed to do so.
- Read the instructions before you begin, and make sure you have the tools and skills required.

- To reduce the possibility of fire or explosion, be careful when working around gasoline. Use only a non-flammable solvent, not gasoline to clean parts. Keep cigarettes, sparks, and flames away from all fuel-related parts.

EMISSION CONTROL SYSTEM INFORMATION

Source of Emissions

The combustion process produces carbon monoxide, oxides of nitrogen, and hydrocarbons. Control of hydrocarbons and oxides of nitrogen is very important because, under certain conditions, they react to form photochemical smog when subjected to sunlight.

Honda utilizes lean PGM-FI and other systems to reduce the emissions of oxides of nitrogen and hydrocarbons.

10. MAINTENANCE

The U. S. Clean Air Act

EPA regulations require all manufacturers to furnish written instructions describing the operation and maintenance of emission control systems.

The following instructions and procedures must be followed in order to keep the emissions from your Honda engine within the emission standards.

Tampering and Altering

Tampering with or altering the emission control system may increase emissions beyond the legal limit. Among those acts that constitute tampering are:

- Removal or alteration of any part of the intake, fuel, or exhaust systems.
- Alterations that would cause the engine to operate outside its design parameters.

Problems That May Affect Emissions

If you are aware of any of the following symptoms, have your engine inspected and repaired by your servicing dealer.

- Hard starting or stalling after starting.
- Rough idle.
- Misfiring or backfiring under load.
- Afterburning (backfiring).
- Black exhaust smoke or high fuel consumption.

Replacement Parts

The emission control systems on your Honda engine were designed, built, and certified to conform with EPA emission regulations. We recommend the use of genuine Honda parts whenever you have maintenance done. These original-design replacement parts are manufactured to the same standards as the original parts, so you can be confident of their performance. The use of replacement parts that are not of the original design and quality may impair the effectiveness of your emission control system.

A manufacturer of an aftermarket part assumes the responsibility that the part will not adversely affect emission performance. The manufacturer or rebuilder of the part must certify that use of the part will not result in a failure of the engine to comply with emission regulations.

Maintenance

Follow the maintenance schedule on pages 91 and 92. Remember that this schedule is based on the assumption that your machine will be used for its designed purpose. Sustained high-load or high-temperature operation, or use in unusually wet or dusty conditions, will require more frequent service.

10. MAINTENANCE

Tool Kit and Spare Parts

The following tools and spare parts are supplied with the outboard motor for maintenance, adjustment, and emergency repairs.

TOOL KIT

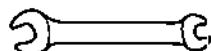

14 x 17 mm WRENCH

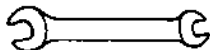

10 x 12 mm WRENCH

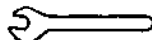

8 mm WRENCH

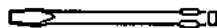

FLAT SCREWDRIVER

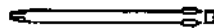

PHILLIPS SCREWDRIVER



OIL CHECK SCREWDRIVER

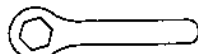

BOX WRENCH



PLIERS



SCREWDRIVER HANDLE

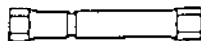

SPARK PLUG WRENCH



TOOL BAG



SPARE EMERGENCY
STOP SWITCH CLIP

MAINTENANCE SCHEDULE

REGULAR SERVICE PERIOD (3)		ITEM	Perform at every indicated month or operating hour intervals, whichever comes first.	EACH USE	FIRST 20 HRS OR MONTH	EVERY 100 HRS OR 6 MONTHS	EVERY 200 HRS OR YEAR	EVERY 400 HRS OR 2 YEARS
●	Engine oil	Check level		○				
		Change			○	○		
	Gear case oil	Check level and check for water contamination				○		
		Change			○(2)		○(2)	
●	Engine oil filter	Change					○	
	Engine timing belt	Check-readjust					○(2)	
	Balancer belt							
	ACG belt							
	Throttle linkage and idling speed	Check			○(2)	○(2)		
		Adjust			○(2)	○(2)		
●	Valve clearance	Check-readjust			○(2)		○(2)	
●	Spark plugs	Check-adjust (Replace if necessary)			○		○	
	Propeller and cotter pin	Check		○				
		(Replace if necessary)				○		
	Lubrication	Grease			○(1)	○(1)		

10. MAINTENANCE

REGULAR SERVICE PERIOD (3)		EACH USE	FIRST 20 HRS OR MONTH	EVERY 100 HRS OR 6 MONTHS	EVERY 200 HRS OR YEAR	EVERY 400 HRS OR 2 YEARS
ITEM	Perform at every indicated month or operating hour intervals, whichever comes first.					
	Fuel tank and tank filter	Clean			○	
	Tank filter	(Replace if necessary)			○	
	Fuel filter	Check		○		
		Change				○
	Fuel filter (High pressure type)	Change				○(2)
●	Thermostat	Check			○(2)	
●	Fuel line	Check	○			
		(Replace if necessary)				○(2)
	Battery cable	Check-tightness		○	○	
	Bolts and Nuts	Check-tightness		○(2)	○(2)	

• Emission-related items

- (1) Lubricate more frequently when used in salt water.
- (2) These items should be serviced by an authorized Honda Marine dealer, unless the owner has the proper tools and is mechanically proficient. See the Honda Shop Manual.
- (3) For professional commercial use, log hours of operation to determine proper maintenance intervals.

Engine Oil

Engine oil is a major factor affecting engine performance, service life, and emission.

Oil check interval:

Each use.

Oil change interval:

After the first 20 hours or 1 month, then every 100 hours or 6 months. (Refer to the maintenance schedule pages 91).

Oil capacity:

5.9 US qt (5.6 lit) ... When oil filter is not replaced
 6.2 US qt (6.5 lit) ... When oil filter is replaced

Recommended oil: SAE 10W-30 or 10W-40

Use 4-stroke motor oil that meets or exceeds the requirements for API service classification SG or SH. Always check the API SERVICE label on the oil container to be sure it includes the letters SG or SH.

NOTICE

Using nondetergent oil can shorten the engine's service life, and using 2-stroke oil can damage the engine.

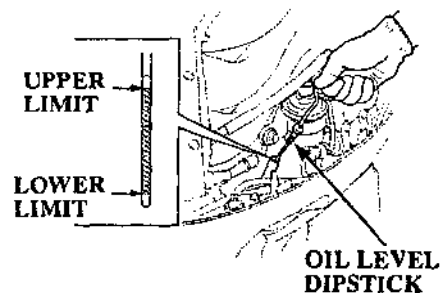

Engine Oil Check

Check the engine oil level with the engine stopped and the outboard motor in the vertical position.

1. Remove the engine cover.
2. Pull out the dipstick and wipe off.
3. Reinsert the dipstick and pull out again to check the level.

If the level is near the lower limit, refill to the upper limit. If the oil is dirty, replace it. If water is contaminated (it becomes white as milk), see your authorized Honda marine dealer.

10. MAINTENANCE

OIL FILLER
CAP

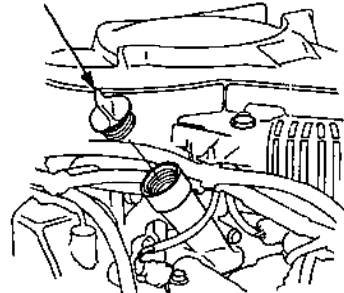

Engine Oil Change

Drain the oil while the engine is still warm to assure rapid and complete draining.

1. Position the outboard motor vertically, and remove the engine cover. Remove the oil filler cap.

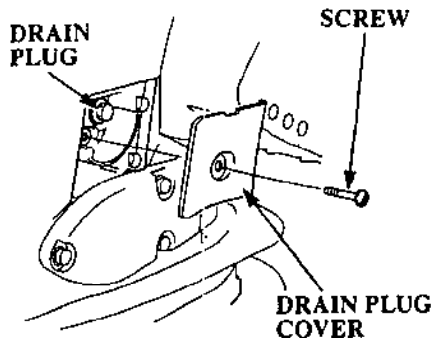

2. Remove the drain plug cover screw using a flat blade screwdriver, and remove the drain plug cover.

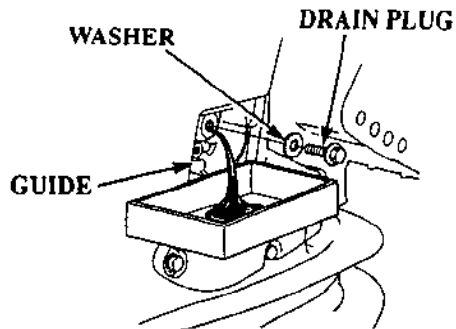

3. Place a suitable container under the guide. Remove the engine oil drain plug and washer using a 12 mm wrench, and drain the engine oil.
4. Install a new sealing washer on the drain plug and tighten the drain plug securely.
5. Reinstall the drain plug cover.
6. Fill with the recommended engine oil (P. 93)

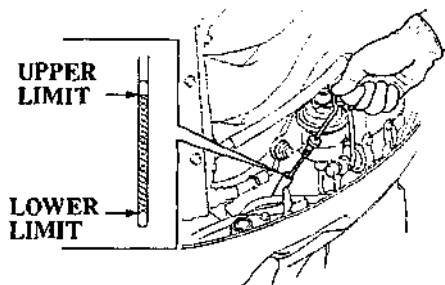

7. Inspect the engine oil level and refill to the upper limit mark on the oil level dipstick if necessary. Fill with the recommended oil.

NOTE: To avoid incorrect gauging of the engine oil level, inspect the oil level when the engine has cooled. The outboard motor needs to be in the vertical position.

8. Reinstall the oil filler cap and tighten securely.

Always wash your hands after handling used oil.

NOTICE

Improper disposal of engine oil can be harmful to the environment. If you change your own oil, please dispose of the used oil properly. Put it in a sealed container, and take it to a recycling center. Do not discard it in a trash bin or dump it on the ground.

10. MAINTENANCE

OIL FILTER CHANGE

1. Drain the engine oil, and reinstall the drain plug and drain plug cover (see *ENGINE OIL CHANGE*, p.94).
2. Tilt the outboard motor, and place a suitable container below the oil drain guide to catch the used oil
3. Use an oil filter socket tool or an oil filter strap wrench to remove the oil filter, and thoroughly drain the filter into the used oil container.

OIL FILTER SOCKET
(commercially available)

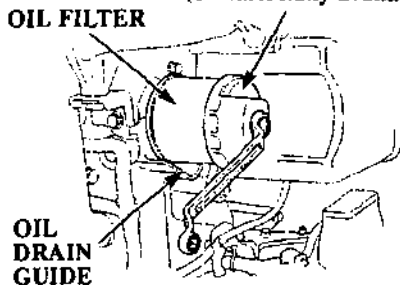

4. Clean the oil filter mounting base, and coat the gasket of the new oil filter with clean engine oil.

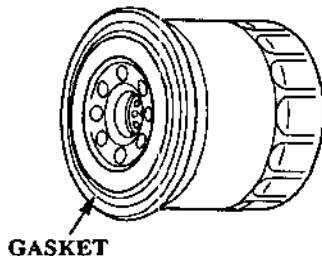

NOTICE

Use only a genuine Honda oil filter or a filter of equivalent quality specified for your model. Using the wrong filter, or a non-honda filter which is not of equivalent quality, may cause engine damage.

5. Screw on the new filter by hand until it contacts the engine, then use an oil filter socket tool or an oil filter strap wrench to tighten the filter an additional 7/8 turn.

Oil filter tightening torque: 16 ft-lb
(22 N·m, 2.2 kg-m).

6. Return the outboard motor to the vertical position, and fill the crankcase with the specified amount (p. 93) of the recommended oil.

7. Start the engine, and check for leaks.

NOTICE

Running the engine without water can cause serious engine damage. If you are changing the oil filter while the outboard motor is out of the water, use the water hose adapter (optional equipment) and a hose (p. 84) to supply water.

8. Stop the engine, and check the oil level as described on page 93. If necessary, add oil to bring the oil level to the upper limit mark on the dipstick.

10. MAINTENANCE

Gear Oil

Oil check interval:

Every 6 months or 100 hours.

Oil change interval:

After the first 20 hours or 1 month, then every 200 hours or 1 year. (Refer to the maintenance schedule page 91).

Oil CAPACITY:

33.8 fl oz. (1.0 lit)

Recommended oil:

SAE, #90 Hypoid gear oil or equivalent, API Service Classification (GL-4 or GL-5).

GEAR OIL CHECK PLUG

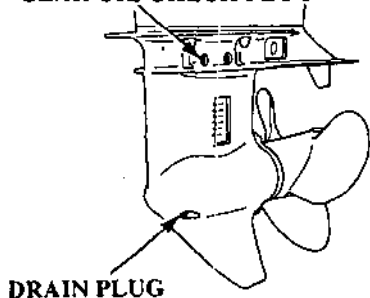

Gear Oil Level Check

1. Position the outboard motor vertically.
2. Remove the level plug and see if oil flows out.
3. Install and tighten the check plug securely.

If there is water in the oil, the water will flow out first when the drain screw is removed, or the oil will be a milky color. Consult with an authorized Honda outboard motor dealer.

Spark Plugs

To ensure proper engine operation, the spark plugs must be properly gapped and free of deposits.

Check-replace interval:

After the first 20 hours or 1 month then every 200 hours or 1 year (Refer to the maintenance schedule page 91).

Recommended spark plug:

ZFR7F (NGK),
KJ22CR-L8 (DENSO)

Use only the recommended spark plugs or equivalent.

NOTICE Spark plugs which have an improper heat range may cause engine damage.

1. Allow the engine to cool. The spark plugs will be hot if the engine has been running.
2. Remove the engine cover.

17 mm WRENCH

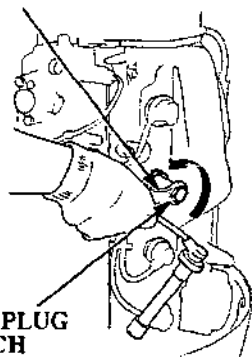

SPARK PLUG WRENCH

3. Disconnect the spark plug caps from the spark plugs.
4. Use the spark plug wrench and 17 mm wrench supplied in the tool kit to remove the spark plugs.
5. Check the spark plugs. Replace the spark plugs if there is apparent wear, or if the insulators are cracked or chipped. Clean the spark plugs with a wire brush if they are to be reused.

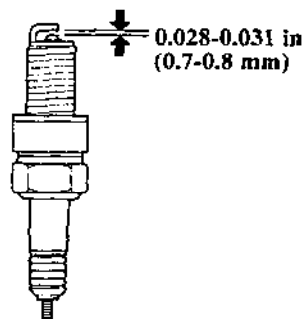

6. Measure the plug gaps with a spark plug gap gauge.

The gaps should be 0.028-0.031 in (0.7-0.8 mm). Correct as necessary by carefully bending the side electrode.

10. MAINTENANCE

7. Thread the plugs in by hand to prevent cross threading.

8. After the spark plugs are seated, tighten with a spark plug wrench and 17 mm wrench to compress the washers.

If installing new spark plugs, tighten 1/2 turn after the spark plugs seat to compress the washers. If reinstalling used spark plugs, tighten 1/8~1/4 turn after the spark plugs seat to compress the washers.

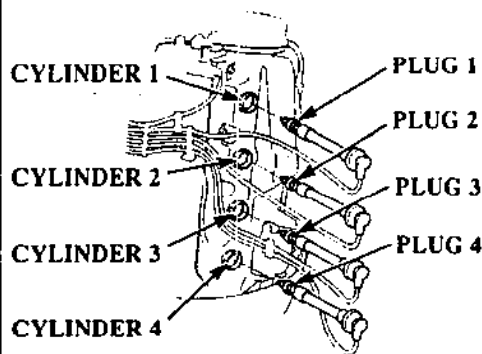

9. Reinstall the spark plug caps, matching the numbers on the cords with the cylinder numbers, as shown.

NOTICE

The spark plugs must be securely tightened. A loose spark plug can become very hot and may cause engine damage. Overtightening the spark plugs can damage the threads.

Battery (not included)
Minimum requirements
12V-80AH marine battery.

To protect the battery from mechanical damage and to prevent the battery from falling or tipping over, the battery must be:

- Installed in the correct size corrosion-resistant battery box.
- Properly secured in the boat.
- Secured in a location free from direct sunlight and water spray.
- Secured away from the fuel tank to avoid potential sparks near the fuel tank.

1. Install the battery in the battery box.
2. Connect the positive (+) battery cable first, then connect the negative (-) battery cable. Tighten the cable nuts securely.
3. Coat the battery terminals and cable ends with marine anticorrosion grease.

4. Put the cover on the battery box, and secure the battery box to the boat.

10. MAINTENANCE

Lubrication

Lubrication interval:

After the first 20 hours or 1 month, then every 100 hours or 6 months. (Refer to the maintenance schedule page 91).

Apply marine anticorrosion grease to the following parts.

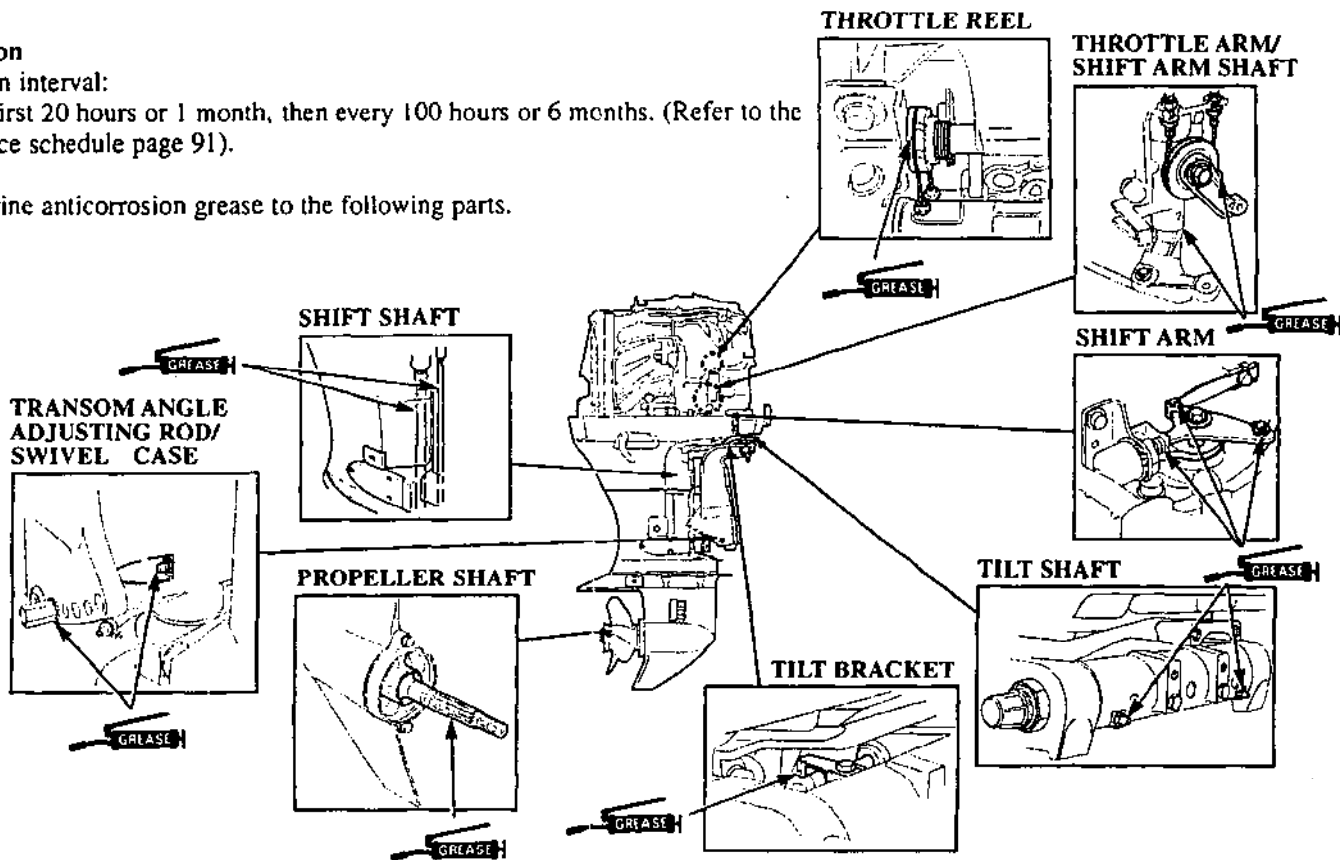

Engine Fuel Filter

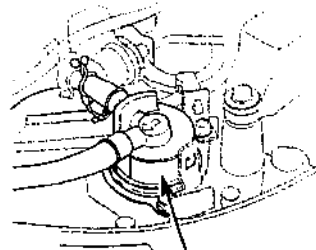

FUEL FILTER

The engine fuel filter is located under the engine cover between the fuel coupling and the fuel pump. Water or sediment accumulated in the fuel filter can cause loss of power or hard starting.

Check interval:

Every 100 hours or 6 months
(Refer to the maintenance schedule page 92).

Change interval:

Every 400 hours or 2 years
(Refer to the maintenance schedule page 92).

Always work in a well-ventilated area. Make sure that any fuel drained from the outboard motor is stored in an approved gasoline container. Be careful not to spill any fuel when replacing the filter. Spilled fuel or fuel vapor may ignite. If any fuel is spilled, make sure the area is dry before starting the engine.

⚠WARNING Gasoline is highly flammable and explosive. You can be burned or seriously injured when handling fuel.

- Stop engine and keep heat, sparks, and flame away.
- Handle fuel only outdoors.
- Wipe up spills immediately.

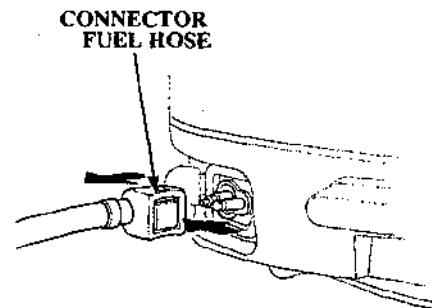

Check

1. Remove the engine cover and disconnect the fuel hose connector from the outboard motor.

10. MAINTENANCE

FUEL FILTER

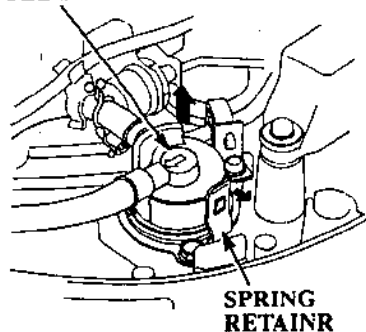

2. Pull the spring retainer toward you, and raise the fuel filter.

3. Check the fuel filter for water accumulation or sediment. If no water or sediment are found, reinstall the fuel filter properly.

FUEL HOSE CLAMPS

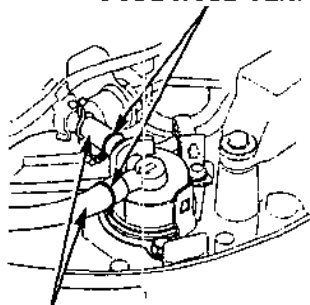

FUEL HOSES

Change

1. Remove the fuel filter.

Before removing the fuel filter, to prevent fuel leakage, place fuel hose clamps on the fuel hoses at each side of the fuel filter.

FUEL FILTER

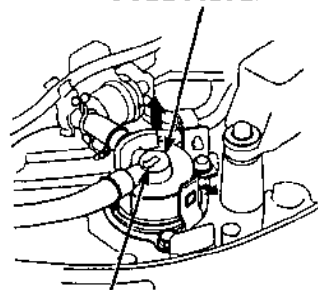

ARROW (Fuel Flow Direction)

2. Install the new fuel filter so the arrow on the fuel filter points toward the fuel pump.

Fuel flow will be reduced if the fuel filter is installed backward.

3. Connect the fuel hoses to the fuel filter securely with the hose clips. Remove the fuel hose clamps used to close the fuel hoses.

4. Securely connect the fuel hose connector to the outboard motor (refer to page 46).
5. Prime the engine using the primer bulb (refer to page 49). Check for fuel leaks. Repair any fuel leaks if necessary.

If loss of power or hard starting are found to be caused by excessive water or sediment accumulation in the fuel filter, inspect the fuel tank.

Clean the fuel tank and tank filter if necessary. It may be necessary to drain the fuel tank completely and refill with fresh gasoline.

Fuel Tank and Filter (optional equipment)

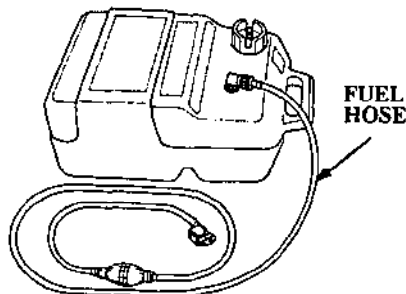

Cleaning interval:

Every 200 hours (Refer to the maintenance schedule page 92).

Inspect the condition of the fuel cap gasket, fuel hose, and the O-ring seals in the fuel hose connectors. Replace the fuel cap gasket, hose, or fuel connectors if they are cracked, damaged or leaking fuel. Be sure the fuel hose is not kinked.

Fuel Tank Cleaning

1. Disconnect the fuel hose from the fuel tank.

▲WARNING Gasoline is highly flammable and explosive, and you can be burned or seriously injured when handling fuel.

- Stop engine and keep heat, sparks, and flame away.
 - Handle fuel only outdoors.
 - Wipe up spills immediately.
2. Empty the gasoline from the fuel tank into an approved gasoline container. Pour in a small quantity of fresh gasoline, and clean the tank thoroughly. Drain and dispose of the gasoline properly.

10. MAINTENANCE

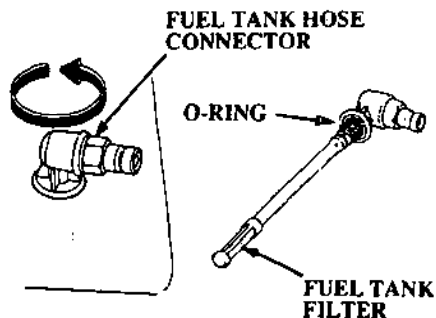

Fuel Tank Filter Cleaning/Replacement

1. Turn the fuel tank hose connector counterclockwise to remove the fuel tank filter.
2. Clean the fuel tank filter with non-flammable cleaner or solvent. Replace the fuel tank filter if necessary.
3. After cleaning or replacement, reinstall the fuel tank filter and fuel tank hose connector securely.

Fuse Replacement

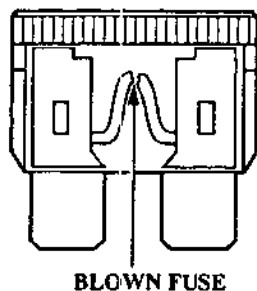

If the fuse is blown, running the engine will not charge the battery, and the electric starter will not work.

FUSE RATING: MAIN 10A, 30A
ACG 90A

NOTICE

Replacing a fuse with one that has a higher rating greatly increases the chances of damaging the electrical system.

If you do not have a replacement fuse with the proper rating for the circuit, install one with a lower rating.

MAIN FUSE

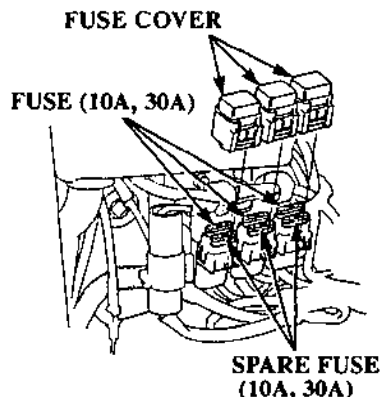

Replacement

1. Stop the engine.
2. Remove the engine cover.
3. Pull the blown fuse out of the clip.
4. Push a new fuse into the clip.

Spare fuses are located in each fuse holder.

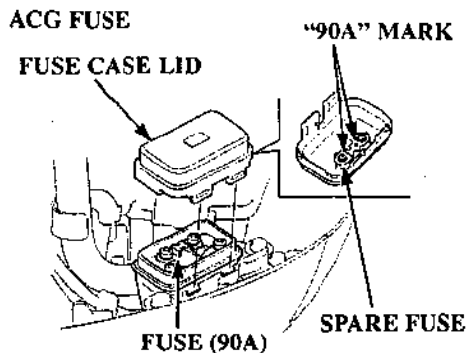
**NOTICE**

Disconnect the battery cable at the battery negative (-) terminal before replacing the fuse. Failure to do so may cause a short circuit.

Replacement

1. Stop the engine.
2. Remove the engine cover.

3. Remove the fuse case lid.
4. Remove the old fuse by removing two 5 mm screws.
5. Install a new fuse with the "90A" mark downward.
6. After finishing replacement, install the fuse case lid with its hook toward the engine side.
7. Be sure to check the fuse case lid is securely locked.

A spare fuse is located on the reverse side of the fuse case lid and tightened with two 3 mm screws.

When the new fuse is set as a spare fuse on the reverse side of the fuse case lid, set the fuse so that you can see the "90A" mark on it.

10. MAINTENANCE

Propeller

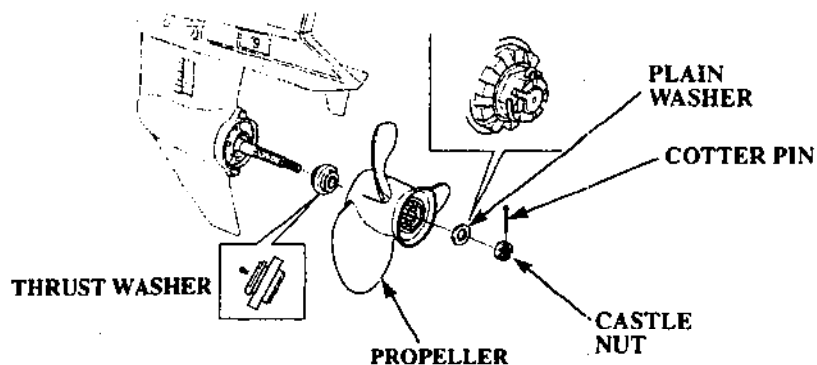

If the propeller is damaged by striking a rock, or other obstacle, replace the propeller as follows.

⚠ WARNING

- **Before replacing the propeller, remove the engine switch key to prevent accidental engine starting.**
- **The propeller is thin and sharp. To protect your hands, wear the heavy gloves during replacement.**

Replacement

1. Remove the cotter pin then remove the 18,5 mm castle nut, 19 mm plain washer, propeller and thrust washer.
2. Install the new propeller in the reverse sequence to removal. Be sure to replace the cotter pin with new one.

NOTE:

- Install the thrust washer with the grooved side toward the gear case.
- Use a genuine Honda cotter pin and bend the pin ends as shown.

Submerged Motor

A submerged motor must be serviced immediately after it is recovered from the water in order to minimize corrosion.

Immediately take the outboard motor to the closest authorized Honda Marine dealer or if you are far from a dealership, proceed as follows:

1. Remove the engine cover, and rinse the motor with fresh water to remove salt water, sand, mud, etc.
2. Drain the vapor separator.
3. Change the engine oil (refer to page 93).
4. Remove the spark plugs.

5. Put a teaspoon of engine oil into each spark plug hole to lubricate the inside of the cylinders. Then rotate the engine several times, using the emergency starter rope. Reinstall the spark plugs.

6. Attempt to start the engine (be sure the water level is at least 2 inches above the antiventilation plate).

NOTICE

Running the outboard motor without sufficient cooling water will damage the water pump and overheat the engine.

- If the engine fails to start, remove the spark plugs, clean and dry the electrodes, then reinstall the spark plugs and attempt to start the engine again.
- If the engine starts, and no mechanical damage is evident, continue to run the engine for a 1/2 hour or longer.

10. MAINTENANCE

- If there was water in the engine crankcase, or the drained used engine oil showed signs of water contamination, then a second engine oil change should be performed after running the engine for a 1/2 hour.
7. Take the outboard motor to your closest authorized Honda Marine dealer for inspection and service as soon as possible.

For longer service life of the outboard motor, have your outboard motor serviced by an authorized Honda Marine dealer before storage.

If you are unable to take the motor to your dealer, proceed as follows:

Draining the Vapor Separator

Be careful not to spill gasoline. Spilled gasoline or gasoline vapor may ignite. If any gasoline is spilled, make sure the area is dry before storing or transporting the motor. Do not smoke or allow flames or sparks where gasoline is drained or stored.

⚠WARNING Gasoline is highly flammable and explosive. You can be burned or seriously injured when handling fuel.

- Stop engine and keep heat, sparks, and flame away.
- Handle fuel only outdoors.
- Wipe up spills immediately.

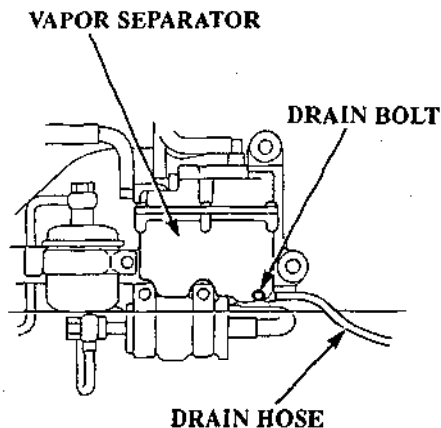

1. Remove the drain hose from the silencer case.
2. Connect the drain hose to the drain joint of the vapor separator and set the other end of the hose toward the outside of the engine undercase.
3. Tilt up the outboard motor.

4. Loosen the vapor separator drain screw and drain the vapor separator.
5. After draining thoroughly, tighten the drain screw securely.
6. Install the drain hose to the silencer case.

11. STORAGE

Fuel Tank (optional equipment)

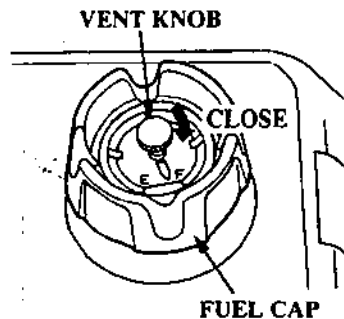

1. Close the fuel cap vent knob.
2. Disconnect the fuel coupling from the outboard motor (refer to page 48).

Outboard Motor Position

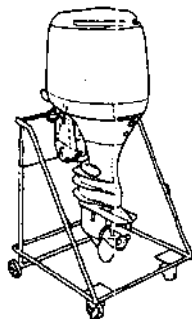

Store the motor vertically, as shown above. Store the outboard motor in a well-ventilated area free from direct sunlight and humidity.

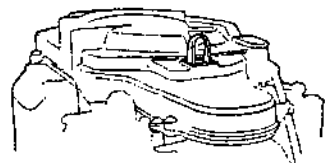

Vertical storage

1. Remove the engine cover.

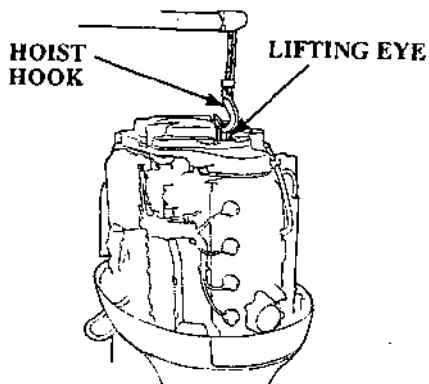

2. Hook the hoist hook to the lifting eye, and lift the motor from the boat.

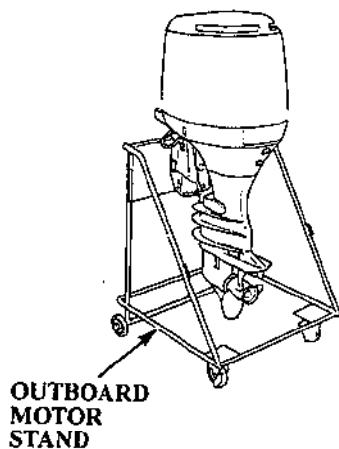

3. Place the motor on an outboard motor stand and secure with bolts and nuts.
4. Remove the lifting eye and install the timing belt cover and engine cover.

Horizontal storage

Before removing the motor from the boat, drain the vapor separator and engine oil. Follow the vapor separator drain procedure on page 111.

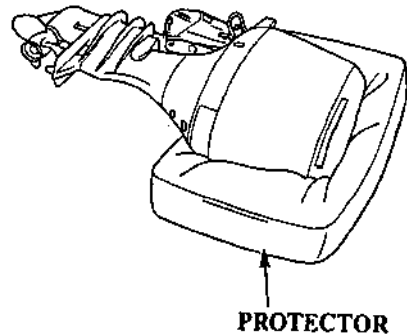

Always rest the motor on protectors, and be sure to protect it from impact and damage.

12. TROUBLESHOOTING

WARNING SYSTEM COMES ON

SYMPTOM	POSSIBLE CAUSE	REMEDY
Overheat indicator system activates: <ul style="list-style-type: none">• Overheat indicator light comes on.• Overheat indicator buzzer sounds.• Engine speed decreases and stops at last.• Engine speed cannot be increased by opening the throttle.	Cooling water intake port clogged.	Clean the cooling water intake port.
	Spark plug has improper heat range.	Replace the spark plug (see page 96).
	<ul style="list-style-type: none">• Faulty water pump• Thermostat clogged• Faulty thermostat• Cooling water passage clogged• Exhaust gas invades cooling system.	Consult with an authorized Honda outboard motor dealer.
Oil pressure indicator system activates: <ul style="list-style-type: none">• Oil pressure indicator light does not come on.• Oil pressure indicator buzzer sounds.• Engine speed decreases.• Engine speed cannot be increased by opening the throttle.	Shortage of engine oil.	Add engine oil to the specified level (see page 38).
	Improper engine oil is used.	Change the engine oil (see page 93).
PGM-FI indicator system activates: <ul style="list-style-type: none">• PGM-FI indicator light comes on.• PGM-FI indicator buzzer sounds intermittently.	PGM-FI indicator system is faulty.	Consult with an authorized Honda outboard motor dealer.
ACG indicator system activates: <ul style="list-style-type: none">• ACG indicator light comes on.• ACG indicator buzzer sounds intermittently.	Battery voltage is too high or low.	Check the battery.
	Faulty ACG	Consult with an authorized Honda outboard motor dealer.

13. SPECIFICATIONS

MODEL	BF115A			
Description Code	BZBD	BZBG	BZBD	BZBG
Type	LA	LCA	XA	XCA
Overall length	825 mm (32.5 in)			
Overall width	550 mm (21.7 in)			
Overall height	L	1,650 mm (65.0 in)		
	UL	1,775 mm (69.9 in)		
Transom height	L	537 mm (21.1 in)		
	UL	664 mm (26.1 in)		
Dry weight	225 kg (496 lb)	228 kg (503 lb)	230 kg (507 lb)	233 kg (514 lb)
Rated power	84.6 kW (115 PS)/5,500 rpm			
Full throttle rpm range	5,000 - 6,000 rpm			
Engine type	4 stroke SOHC in-line 4 cylinder			
Displacement	2,254 cc (137.5 cu-in)			
Spark plug gap	0.7 - 0.8 mm (0.028 - 0.031 in)			

Starter system	Electric starter
Ignition system	Full transistor battery
Lubrication system	Trochoid pump pressure lubrication
Specified oil	Engine: API standard SG, SH SAE 10W-30/40 Gear case: API standard GL-4/5 SAE 90 outboard motor gear oil
Oil capacity	Engine: 5.6 ℓ (5.9 US qt, 4.9 Imp qt) Gear case: 1.0 ℓ (1.1 US qt, 0.9 Imp qt)
D.C. output	12 V - 40 A
Cooling system	Water cooling with thermostat
Exhaust system	Water exhaust
Spark plugs	KJ22CR-L8 (DENSO) ZFR7F (NGK)
Fuel pump	Diaphragm type
Fuel	Automotive gasoline (86 pump octane)
Gear change	Forward-Neutral-Reverse (dog type)
Steering angle	30° right and left
Transom angle	5 stages (8°, 12°, 16°, 20°, 24°)

13. SPECIFICATIONS

MODEL	BF130A			
Description Code	BZBE	BZBH	BZBE	BZBH
Type	LA	LCA	XA	XCA
Overall length	825 mm (32.5 in)			
Overall width	550 mm (21.7 in)			
Overall height	L	1,650 mm (65.0 in)		
	UL	1,775 mm (69.9 in)		
Transom height	L	537 mm (21.1 in)		
	UL	664 mm (26.1 in)		
Dry weight	225 kg (496 lb)	228 kg (503 lb)	230 kg (507 lb)	233 kg (514 lb)
Rated power	95.6 kW (130 PS)/5,500 rpm			
Full throttle rpm range	5,000 – 6,000 rpm			
Engine type	4 stroke SOHC in-line 4 cylinder			
Displacement	2,254 cc (137.5 cu-in)			
Spark plug gap	0.7 – 0.8 mm (0.028 – 0.031 in)			

Starter system	Electric starter
Ignition system	Full transistor battery
Lubrication system	Trochoid pump pressure lubrication
Specified oil	Engine: API standard SG, SH SAE 10W-30/40 Gear case: API standard GL-4/5 SAE 90 outboard motor gear oil
Oil capacity	Engine: 5.6 ℓ (5.9 US qt, 4.9 Imp qt) Gear case: 1.0 ℓ (1.1 US qt, 0.9 Imp qt)
D.C. output	12 V – 40 A
Cooling system	Water cooling with thermostat
Exhaust system	Water exhaust
Spark plugs	KJ22CR-L8 (DENSO) ZFR7F (NGK)
Fuel pump	Diaphragm type
Fuel	Automotive gasoline (86 pump octane)
Gear change	Forward-Neutral-Reverse (dog type)
Steering angle	30° right and left
Transom angle	5 stages (8°, 12°, 16°, 20°, 24°)

Warranty Service Information

Servicing dealership personnel are trained professionals. They should be able to answer any question you may have. If you encounter a problem that your dealer does not solve to your satisfaction, please discuss it with the dealership's management. The Service Manager or General Manager can help. Almost all problems are solved in this way.

If you are dissatisfied with the decision made by the dealership's management, contact the Honda Marine Customer Relations Office. You can write:

American Honda Motor Co., Inc.
Marine Division
Customer Relations Office
4475 River Green Parkway
Duluth, Georgia 30096-2565
Or telephone: (770) 497-6400

When you write or call, please give us this information:

- Model and serial numbers (see page 4)
- Name of the dealer who sold the outboard motor to you
- Name and address of the dealer who services your outboard motor
- Date of purchase
- Your name, address, and telephone number
- A detailed description of the problem

Current customer service contact information:

Your owner's manual was written to cover most of the questions you might ask about your Honda. Any questions not answered in the owner's manual can be answered by your Honda dealer. If your dealer doesn't have an immediate answer, they should be able to get it for you.

If you have a difference of opinion with your dealer, please remember that each dealership is independently owned and operated. That's why it's important to work to resolve any differences at the dealership level. If the service personnel are unable to assist you, please discuss your concerns with the dealer management such as the Service Manager or the dealership's owner.

If you need to contact American Honda regarding your experiences with your Honda product or with your dealer, please send your comments to the following address:

American Honda Motor Co., Inc.
Marine Division
Customer Relations Office
4900 Marconi Drive
Alpharetta, GA 30005-8847

Or telephone: (770) 497-6400 M-F, 8:30 am - 7:00 pm EST

When you write or call, please provide the following information:

- Your name, address and telephone number (complete with area code)
- Model and complete serial number
- Date of purchase
- Name and location of the selling dealer
- Name and location of the servicing dealer (if different)
- A detailed description of your concerns

15. INDEX

ACG Indicator Light/Buzzer	18, 23, 29
Anode Metal	35
PRE-OPERATION CHECK	47
MOTOR PROTECTION SYSTEM	76
Battery (not included)	100
Break-in Procedure	60
CLEANING AND FLUSHING	84
COMPONENT IDENTIFICATION	10
Control Lever Friction Adjustment	45
CONTROLS & INSTRUMENTS	
(SIDE-MOUNT TYPE)	14
(PANEL-MOUNT TYPE)	20
(TOP-MOUNT TYPE)	26
Cooling System Indicator	35
Cruising	
(SIDE-MOUNT TYPE)	62
(PANEL-MOUNT TYPE)	64
(TOP-MOUNT TYPE)	66
Emergency Stop Switch Lanyard	
(SIDE-MOUNT TYPE)	16
(PANEL-MOUNT TYPE)	22
(TOP-MOUNT TYPE)	28
Engine Cover Removal/Installation	39
Engine Fuel Filter	103
Engine Oil Pressure, Overheat, PGM-F1 and ACG Indicator Systems	73
Engine Oil	
Level Check	40
Change	93

Filter Change	96
Fast Idle Lever	17
Fuel	
Cap/Gauge/Vent/Knob (optional fuel tank)	37
Level	41
Line Connection	48
Optional Fuel Tank	48
Tank and Filter (optional fuel tank)	105
Fuel Recommendations	42
Fuse Replacement	106
Gear Oil	98
Gear Shifting	
(SIDE-MOUNT TYPE)	61
(PANEL-MOUNT TYPE)	63
(TOP-MOUNT TYPE)	65
Ignition Switch	
(SIDE-MOUNT TYPE)	15
(PANEL-MOUNT TYPE)	21
(TOP-MOUNT TYPE)	27
IMPORTANT SAFETY INFORMATION	7
Lubrication	102
MAINTENANCE	
EMISSION CONTROL SYSTEM INFORMATION	87
MAINTENANCE SAFETY	87
SCHEDULE	91
THE IMPORTANCE OF MAINTENANCE	86
Manual	
Relief Valve CONTROLS	33

OPERATION	70	SAFETY LABEL LOCATIONS	9
MOTOR PROTECTION SYSTEM	73	Shallow Water Operation	77
Neutral Release Lever		Spark Plug	99
(SIDE-MOUNT TYPE)	15	SPECIFICATIONS	115
(PANEL-MOUNT TYPE)	21	STARTING THE ENGINE	
Oil Pressure Indicator Light/Buzzer		(SIDE-MOUNT TYPE)	50
(SIDE-MOUNT TYPE)	18	(PANEL-MOUNT TYPE)	53
(PANEL-MOUNT TYPE)	24	(TOP-MOUNT TYPE)	56
(TOP-MOUNT TYPE)	30	Stern bracket	
Other Checks	47	PRE-OPERATION CHECK	47
Over-Rev Limiter	37	STOPPING THE ENGINE	
Overheat Indicator Light/Buzzer		(SIDE-MOUNT TYPE)	78
(SIDE-MOUNT TYPE)	18	(PANEL-MOUNT TYPE)	79
(PANEL-MOUNT TYPE)	24	(TOP-MOUNT TYPE)	80
(TOP-MOUNT TYPE)	30	STORAGE	111
Oxygenated Fuels	43	Submerged Motor	109
Power Tilt Switch (Motor Pan)		Tachometer	32
CONTROLS	32	Tilt Lock Lever	
OPERATION	67	CONTROLS	34
Power Trim Tilt Switch		OPERATION	71
(SIDE-MOUNT TYPE)	19	Tilting motor	
(PANEL-MOUNT TYPE)	25	POWER TRIM/TILT	67
(TOP-MOUNT TYPE)	31	Tool Kit	47
PRE-OPERATION CHECKS	39	Tool Kit and Spare Parts	90
Propeller	108	Transom Angle Adjusting Rod	36
Cotter pin	44	TRANSPORTING	81
Remote Control Lever		Trim Meter	
(SIDE-MOUNT TYPE)	14	Controls	32
(PANEL-MOUNT TYPE)	20	Operation	69
(TOP-MOUNT TYPE)	26	Trim Tab	

15. INDEX

Controls	34
Adjustment	72
TRUBLESHOOTING	114
Troubleshooting, Starting Problems	59
WARRANTY SERVICE	117
Water Intakes	35
WIRING DIAGRAM	121

16. WIRING DIAGRAM

PANEL/TOP-MOUNT

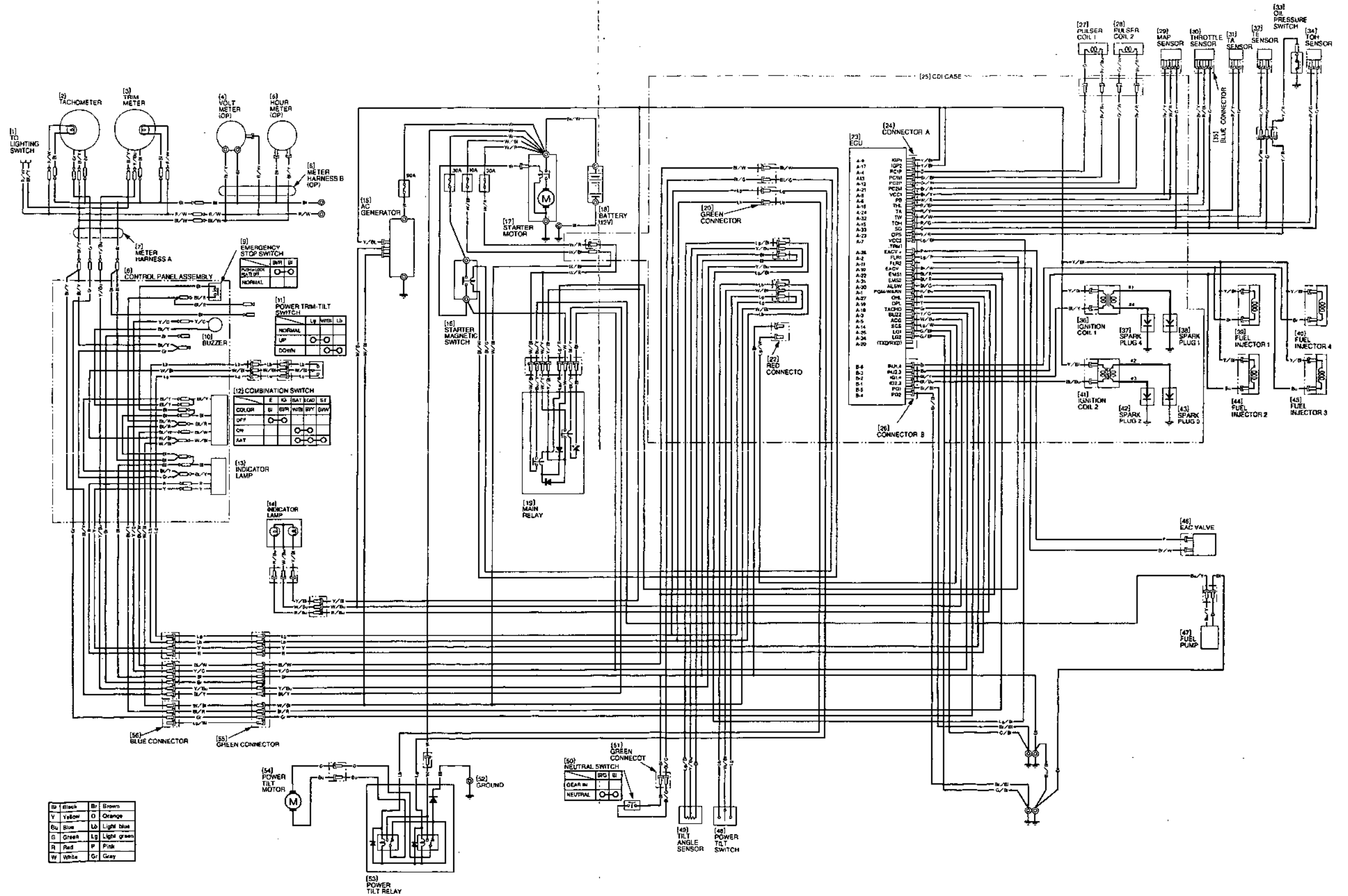

SIDE-MOUNT TYPE

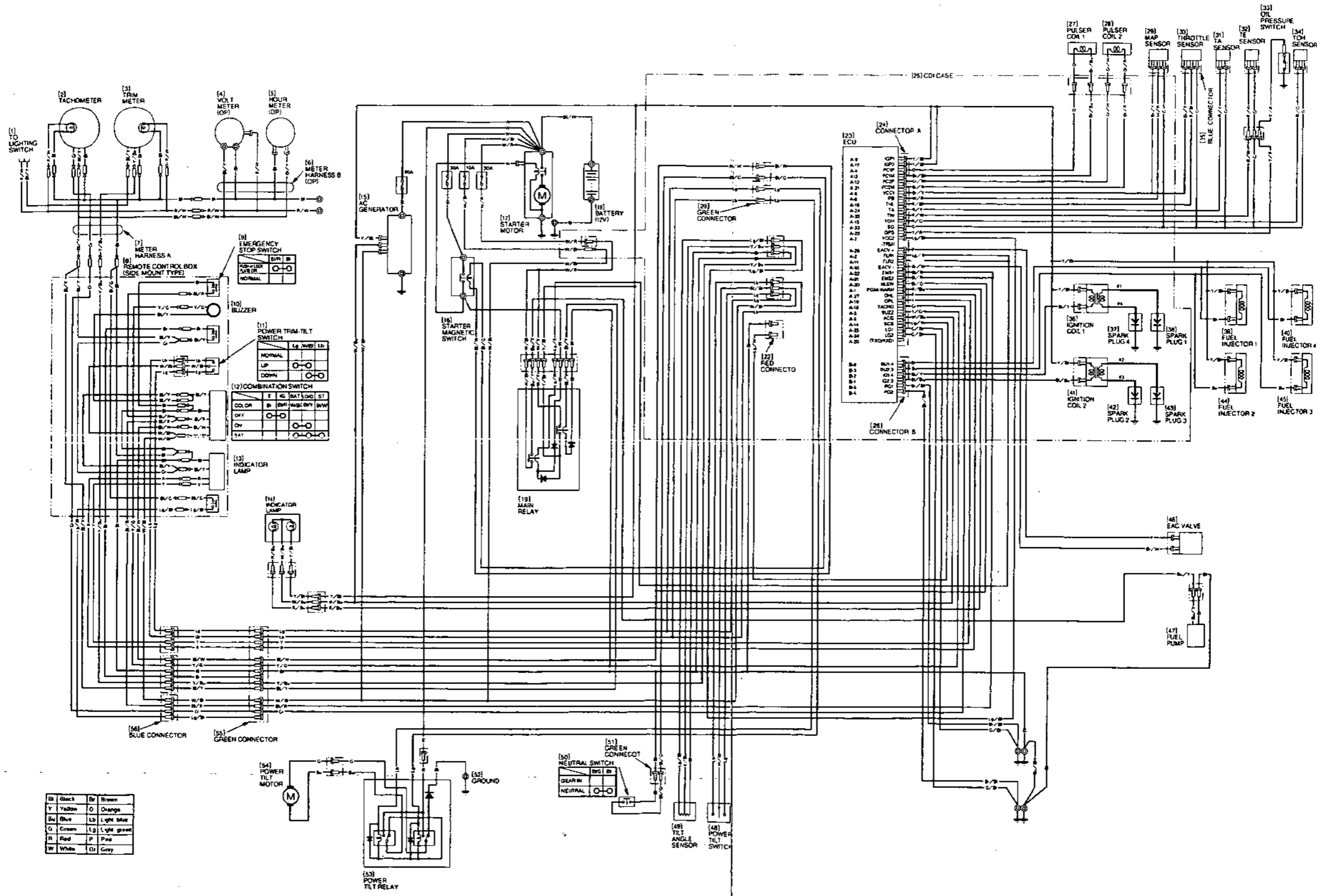

B	Black	Br	Brown
Y	Yellow	O	Orange
Bl	Blue	Lb	Light blue
G	Green	Lg	Light green
R	Red	P	Pink
W	White	Gr	Gray

HONDA

31ZW5600
'00X31-ZW5-6000

POM61877

EM

ARM 1509908

PRINTED IN U.S.A.