



# *Espree™ Series*

## **INSTALLATION AND OPERATING INSTRUCTIONS**

**Installer: Leave this manual for homeowner.**

**Homeowner: Read this manual and keep for future reference.**

# IMPORTANT SAFETY INSTRUCTIONS

## READ AND FOLLOW ALL INSTRUCTIONS

### SAVE THESE INSTRUCTIONS

 **CAUTION:** TEST THE GROUND FAULT CIRCUIT INTERRUPTER PROTECTING THIS APPLIANCE PERIODICALLY IN ACCORDANCE WITH MANUFACTURER'S INSTRUCTIONS.

**WARNING:** RISK OF ACCIDENTAL INJURY OR DROWNING; CHILDREN SHOULD NOT USE HYDROMASSAGE BATHTUB WITHOUT ADULT SUPERVISION.

**WARNING:** TO AVOID INJURY, EXERCISE CAUTION WHEN ENTERING OR EXITING THE HYDROMASSAGE BATHTUB

**WARNING:** RISK OF ACCIDENTAL INJURY OR DROWNING; DO NOT USE HYDROMASSAGE BATHTUB UNLESS ALL SUCTION GUARDS ARE INSTALLED TO PREVENT BODY AND HAIR ENTRAPMENT.

**WARNING:** KEEP BODY AND HAIR A MINIMUM OF 6" AWAY FROM SUCTION FITTING AT ALL TIMES WHEN THE WHIRLPOOL SYSTEM IS OPERATING. HAIR LONGER THAN SHOULDER LENGTH SHOULD BE SECURED CLOSE TO THE HEAD.

**WARNING:** NEVER DROP OR INSERT ANY OBJECT INTO ANY OPENING.

**WARNING:** RISK OF ELECTRICAL SHOCK; DO NOT PERMIT ELECTRICAL APPLIANCES (SUCH AS HAIR DRYER, LAMP, TELEPHONE, RADIO OR TELEVISION) WITHIN 60" (1.5 M) OF THIS HYDROMASSAGE BATHTUB.

**WARNING:** RISK OF ACCIDENTAL INJURY OR DROWNING; DO NOT USE DRUGS OR ALCOHOL BEFORE OR DURING THE USE OF HYDROMASSAGE BATHTUB EQUIPPED WITH A HEATER TO AVOID UNCONSCIOUSNESS AND POSSIBLE DROWNING.

**WARNING:** RISK OF FETAL INJURY; PREGNANT OR POSSIBLY PREGNANT WOMEN SHOULD CONSULT A PHYSICIAN BEFORE USING A HYDROMASSAGE BATHTUB EQUIPPED WITH A HEATER.

**WARNING:** RISK OF HYPERTHERMIA AND POSSIBLE DROWNING; DO NOT USE A HYDROMASSAGE BATHTUB EQUIPPED WITH A HEATER IMMEDIATELY FOLLOWING STRENUOUS EXERCISE.

**WARNING:** RISK OF HYPERTHERMIA AND POSSIBLE DROWNING; WATER TEMPERATURE IN EXCESS OF 104°F (40° C) MAY BE INJURIOUS TO YOUR HEALTH. CHECK AND ADJUST WATER TEMPERATURE BEFORE USE.

**WARNING:** RISK OF HYPERTHERMIA; PEOPLE USING MEDICATIONS AND/OR HAVING AN ADVERSE MEDICAL HISTORY SHOULD CONSULT A PHYSICIAN BEFORE USING A HYDROMASSAGE BATHTUB EQUIPPED WITH A HEATER.

AN EQUIPMENT GROUNDING TERMINAL IS PROVIDED IN THE FIELD WIRING COMPARTMENT. TO REDUCE THE RISK OF ELECTRICAL SHOCK, THIS TERMINAL MUST BE CONNECTED TO THE GROUNDING MEANS PROVIDED IN THE ELECTRICAL SUPPLY PANEL WITH A CONNECTOR EQUIVALENT IN SIZE TO THE CIRCUIT CONNECTORS SUPPLYING THIS EQUIPMENT.

## PRECAUTIONS

- Do not operate the whirlpool system unless the bath is filled with water to at least 2" above the highest jet.
- Never drop or insert any object into any opening.
- Do not use oil-based bath additives in your whirlpool bath.
- When cleaning your bath, do not use abrasive substances which will damage the bath's surface.
- To prevent discoloration of the acrylic finish, do not fill the bath with water in excess of 140°F (60°C).
- The whirlpool system should be purged at least twice a month. For your convenience, we have developed a plumbing system cleaner (Systems Clean™) specifically for whirlpool baths. For availability call 1-800-288-4002.
- Use this unit only for its intended purpose as described in this manual. Do not use attachments not recommended by the manufacturer.
- This unit must be connected only to a supply circuit that is protected by a ground fault circuit interrupter (GFCI). Such a GFCI should be provided by the installer and should be tested on a routine basis. To test the GFCI, push the test button. The GFCI should interrupt power. Push the reset button. Power should be restored. If the GFCI fails to operate in this manner, there is a ground current flowing, indicating a possibility of an electric shock. Do not use this unit. Disconnect the unit and have the problem corrected by a qualified electrician before using.
- A pressure wire connector is provided on the exterior of the motor to permit connection of an No. 8 AWG (8.4 mm) solid copper bonding conductor between this unit and all other electric equipment and exposed metal in the vicinity, as needed to comply with local requirements.
- This unit should be installed by a licensed electrician and grounded.
- For built-in and drop-in units, install to permit access for servicing.

**Note: This is a professional grade product. A knowledge of construction techniques, plumbing and electrical installation according to codes are required for proper installation and user satisfaction. We recommend that a licensed contractor perform the installation of all Jacuzzi Whirlpool Bath products. Our warranty does not cover improper installation related problems.**

# CONTENTS

Specifications _____	1-2
Roughing-in Reference _____	3-4
Installation _____	5-8
Framing and Support _____	5
Service Access _____	6
Electrical Connections _____	7
Plumbing and Water Supply _____	8
Operation _____	9-10
Maintenance _____	11
Troubleshooting _____	12
Authorized Service _____	13
Repair Parts _____	14-18
BMH Jet & 1 Position Air Control _____	14
2 Position Control (Air & Pump/Motor ON/OFF) _____	15
HTC Jet & Suction Assembly _____	16
Back Massage Jet Assembly _____	16
3 Position Control _____	17
Pump/Motor Assembly, RapidHeat Heater, Union Repair Kit, Air Actuated Switch & Strain Relief _____	18
Warranty _____	19-20

## ***Owner's Record***

Date Purchased \_\_\_\_\_

Purchased From \_\_\_\_\_

Installed By \_\_\_\_\_

Serial Number \_\_\_\_\_

Model \_\_\_\_\_

NOTE: To obtain a referral for a service agent in your area call 800-288-4002 . You may also visit our web site at <http://www.jacuzzi.com/>. To find the service agent listing, click on For The Trade. Then click on Electrical/Mechanical Service Agents. Depending on the problem, click on Electrical/Mechanical Repairs or Finish, Surface or Shell-Related Problems or Repair Parts or Accessories for a listing of authorized agents, contractors, or distributors.

# SPECIFICATIONS

## Important: Read complete instructions before beginning installation.

Each whirlpool bath arrives ready for installation, completely equipped with motor/pump assembly and plumbing and fittings necessary for whirlpool operation. An optional drain/overflow kit is available for installation on the bath.

Remove the bath from the carton. Retain the shipping carton until satisfactory inspection of the product has been made. **Do not lift the bath by the plumbing at any time; handle by the shell only.**

Immediately upon receipt, inspect the shell before installing. Should inspection reveal any damage or defect in the finish, do not install the bath. Damage or defect to the finish claimed after the bath is installed is excluded from the warranty. Jacuzzi Whirlpool Bath's responsibility for shipping damage ceases upon delivery of the products in good order to the carrier. Refer any claims for damage to the carrier. For definitions of warranty coverage and limitations, refer to the published warranty information packed with the product.

All bath units are factory tested for proper operation and watertight connections prior to shipping. **Note: Prior to installation, the bath must be filled with water and operated to check for leaks that may have resulted from shipping damage or mishandling.** Jacuzzi Whirlpool Bath is not responsible for any defect that could have been discovered, repaired, or avoided by following this inspection and testing procedure.

### RECTANGULAR BATHS

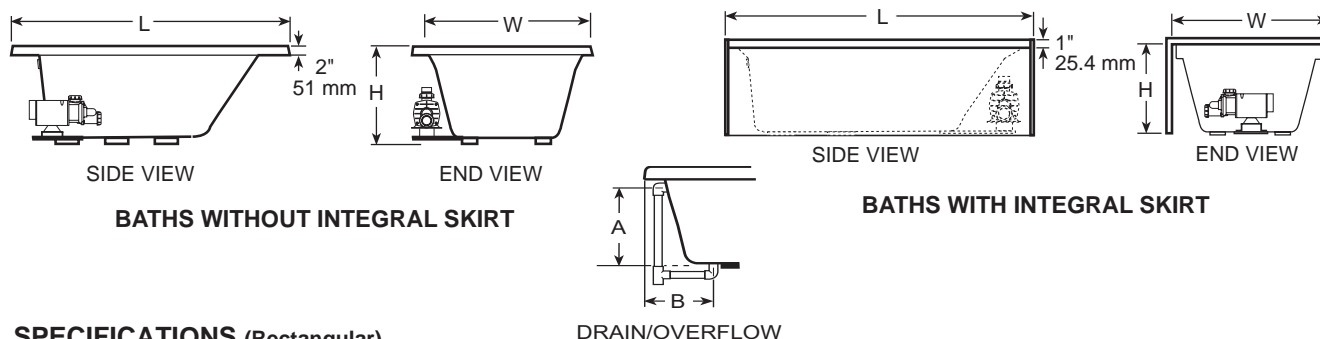

### SPECIFICATIONS (Rectangular)

MODEL	DIMENSIONS	DRAIN/OVERFLOW DIMENSIONS	CUTOUT	TOTAL WEIGHT/ FLOOR LOADING	AVERAGE OPERATING GALLONAGE	PRODUCT WEIGHT	SKIRT & MOUNTING	HEATER READY FOR FIELD INSTALLATION
<b>ESPREE 542** BACK MASSAGE</b>	60" (1524 mm) L 42" (1067 mm) W 20" (508 mm) H	16-7/8" (429 mm) A 15-5/8" (397 mm) B	58" x 40"	936 lb (425 kg)/ 54 lb/sq. ft. (263 kg/sq. m)	58 Min U.S. gal (219 liters) 66 Max U.S. gal (250 liters)	128 lb (58 kg)	Not Available	Yes (S750000 HEATER KIT)
<b>ESPREE 6032</b>	60" (1524 mm) L 32" (813 mm) W 22" (559 mm) H	18-1/16" (459 mm) A 10-1/4" (273 mm) B	See Page 4	785 lb (357 kg)/ 59lb/sq. ft. (288 kg/sq. m)	50 Min U.S. gal (189 liters) 58 Max U.S. gal (220 liters)	102 lb (46 kg)	Not Available	Yes (S750000 HEATER KIT)
<b>ESPREE 6032 WITH INTEGRAL SKIRT</b>	60" (1524 mm) L* 32" (813 mm) W 22" (559 mm) H	16-7/8" (429 mm) A 10-13/16" (275 mm) B	NA	785 lb (357 kg)/ 59lb/sq. ft. (288 kg/sq. m)	50 Min U.S. gal (189 liters) 58 Max U.S. gal (220 liters)	113 lb (51 kg)	Integral	Yes (S750000 HEATER KIT)
<b>ESPREE 6036</b>	60" (1524 mm) L 36" (914 mm) W 20" (508 mm) H	16-7/8" (429 mm) A 15-5/8" (397 mm) B	58" x 34"	825 lb (375 kg)/ 55 lb/sq. ft. (268 kg/sq. m)	50 Min U.S. gal (189 liters) 61 Max U.S. gal (231 liters)	117 lb (53 kg)	Not Available	Yes (U395000 HEATER KIT)
<b>ESPREE 6042</b>	60" (1524 mm) L 42" (1067 mm) W 20" (508 mm) H	16-7/8" (429 mm) A 15-5/8" (397 mm) B	58" x 40"	936 lb (425 kg)/ 67 lb/sq. ft. (326 kg/sq. m)	60 Min U.S. gal (227 liters) 68 Max U.S. gal (257 liters)	127 lb (58 kg)	Not Available	Yes (S750000 HEATER KIT)
<b>ESPREE 6042 WITH INTEGRAL SKIRT</b>	60" (1524 mm) L* 42" (1067 mm) W 20" (508 mm) H	16-7/8" (429 mm) A 10-13/16" (275 mm) B	NA	893 lb (406 kg)/ 51 lb/sq. ft. (249 kg/sq. m)	60 Min U.S. gal (227 liters) 68 Max U.S. gal (257 liters)	127 lb (57 kg)	Integral	Yes (S750000 HEATER KIT)
<b>ESPREE 7236</b>	72" (1829 mm) L 36" (914 mm) W 20" (508 mm) H	16-7/8" (432 mm) A 15-5/8" (394 mm) B	70" X 34"	911 lb (414 kg)/ 51 lb/sq. ft. (249 kg/sq. m)	64 Min U.S. gal (242 liters) 73 Max U.S. gal (276 liters)	120 lb (55 kg)	Not Available	Yes (U395000 HEATER KIT)
<b>ESPREE 7242</b>	72" (1829 mm) L 42" (1067 mm) W 20" (508 mm) H	16-7/8" (432 mm) A 15-5/8" (394 mm) B	70" X 40"	886 lb (403 kg)/ 42 lb/sq. ft. (205 kg/sq. m)	74 Min U.S. gal (280 liters) 89 Max U.S. gal (336 liters)	120 lb (55 kg)	Not Available	Yes (U395000 HEATER KIT)

\*Add 1/4" to this dimension when roughing-in for 3-wall niche.

**NOTE: The overall dimensions are nominal with a tolerance of +0 and -1/4".**

**FOR ALL UNITS:** Electrical Service Requirements: All require a dedicated GFCI protected separate circuit.

RapidHeat: 115 VAC, 15 AMP, 60 Hz. dedicated GFCI protected separate circuit.

Motor/Pump: 115 VAC, 15 Amp, 60 Hz. dedicated GFCI protected separate circuit.

\*\*115VAC, 20AMP, 60Hz. \*115VAC, 20AMP, 60Hz.

# SPECIFICATIONS

## CORNER BATHS

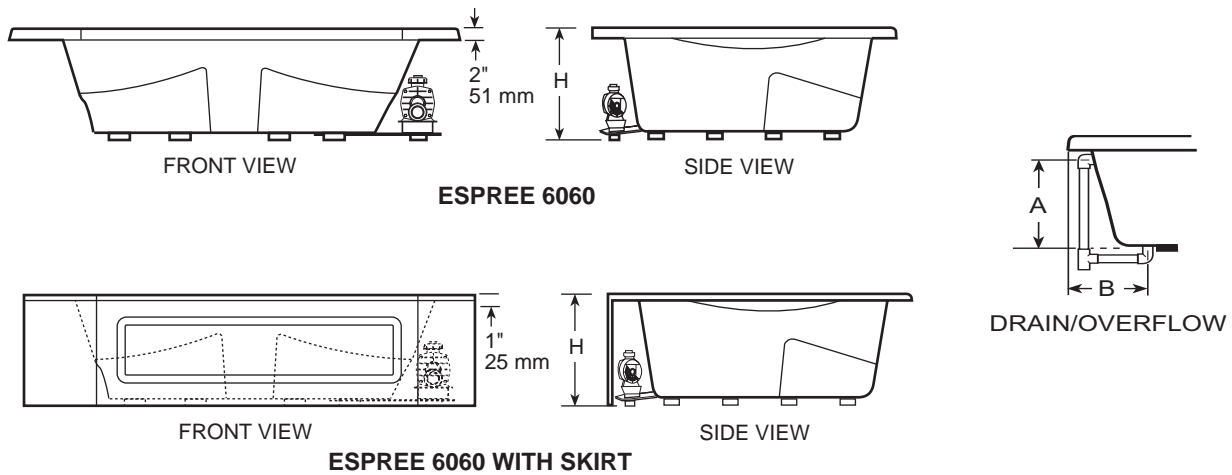

## SPECIFICATIONS (Corner)

MODEL	DIMENSIONS	DRAIN/OVERFLOW DIMENSIONS	CUTOUT	TOTAL WEIGHT/ FLOOR LOADING	OPERATING GALLONAGE	PRODUCT WEIGHT	SKIRT & MOUNTING	HEATER READY FOR FIELD INSTALLATION
<b>ESPREE 6060</b>	60" (1524 mm) L 60" (1524 mm) L 22" (559 mm) H	18-1/2" (470 mm) A 12-1/4" (311 mm) B	See Page 4	888 lb (404 k/g)/ 36 lb/sq. ft. (176 kg/sq. m)	68 Min U.S. gal (257 liters) 89 Max U.S. gal (336 liters)	122 lb (55 kg)	Not Available	Factory Installed (S750000 HEATER KIT)
<b>ESPREE 6060 WITH INTEGRAL SKIRT</b>	60" (1524 mm) L 60" (1524 mm) L 22" (559 mm) H	18-1/2" (470 mm) A 12-1/4" (311 mm) B	NA	888 lb (404 k/g)/ 36 lb/sq. ft. (176 kg/sq. m)	68 Min U.S. gal (257 liters) 89 Max U.S. gal (336 liters)	122 lb (55 kg)	Integral	Factory Installed (U395000 HEATER KIT)

**NOTE: The overall dimensions are nominal with a tolerance of +0 and -1/4".**

**FOR ALL UNITS:** Electrical Service Requirements: All require a dedicated GFCI protected separate circuit.

RapidHeat: 115 VAC, 15 AMP, 60 Hz. dedicated GFCI protected separate circuit.

Motor/Pump: 115 VAC, 15 Amp, 60 Hz. dedicated GFCI protected separate circuit.

## OPTIONS FOR ALL UNITS

		<b>Rotary Drain/Overflow</b>	
<b>Lamp Package 7701XXX</b>	<b>Jet Trim Kit X163XXX</b>	<b>Kit 8730XXX</b>	<b>RapidHeat™ In Line Heater</b>
959 White	805 Platinum	805 Platinum	Suction Side S750000
958 Almond	815 Satin Nickel	815 Satin Nickel	Discharge Side U395000
969 Oyster	826 Brushed Nickel	826 Brushed Nickel	
	827 Chrome	827 Chrome	
	829 PVD Brass	829 PVD Brass	
	898 Brushed Chrome	898 Brushed Chrome	
	845 Oil Rubbed Bronze	845 Oil Rubbed Bronze	

# ROUGH-IN

Note: Unless otherwise specified, units are produced with left or right-hand versions.

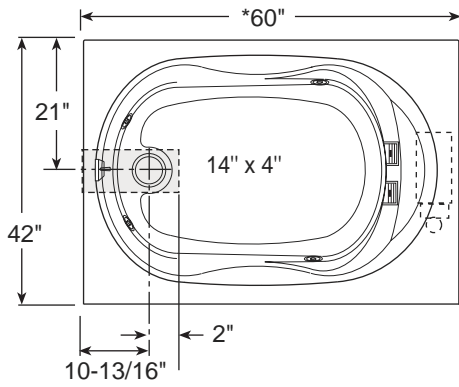

(Left hand shown)  
**ESPREE 6042 BM**

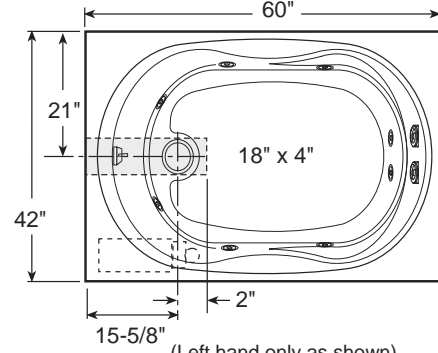

(Left hand only as shown)  
**ESPREE 6042**

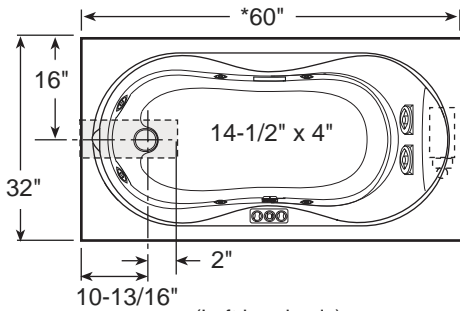

(Left hand only)  
**ESPREE 6032**

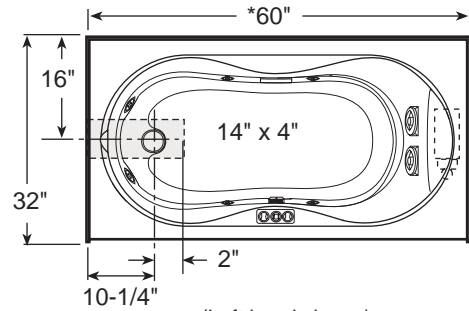

(Left hand shown)  
**ESPREE 6032 WITH SKIRT**

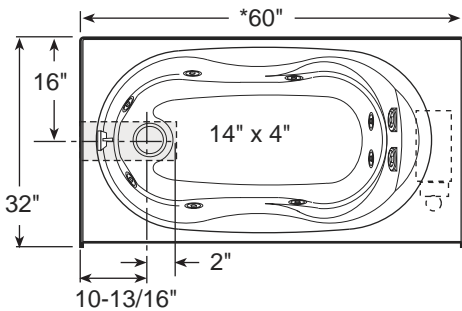

(Left hand shown)  
**ESPREE 6032 WITH SKIRT**

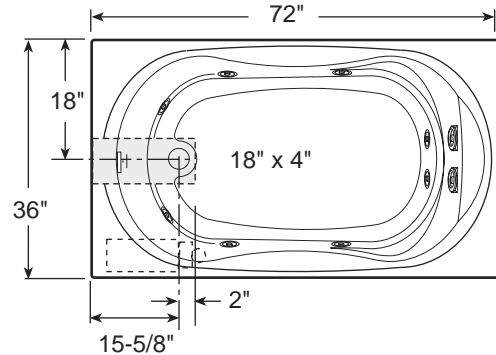

(Left hand only as shown)  
**ESPREE 7236**

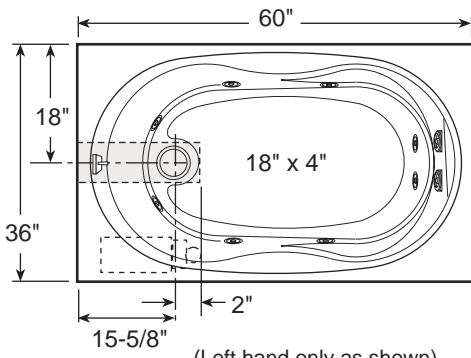

(Left hand only as shown)  
**ESPREE 6036**

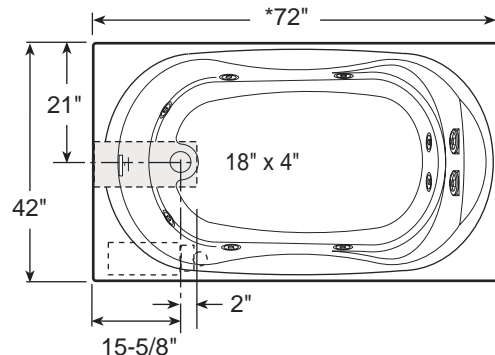

(Left hand only as shown)  
**ESPREE 7242**

- Note: 1. The overall dimensions are nominal with a tolerance of +0 and -1/4".  
2. \*Add 1/4" to this dimension when roughing-in for 3-wall niche.  
3. Measurements inside each unit represent cutout in floor to allow for drain/overflow.  
4. All measurements are in inches. To convert to millimeters, multiply inches by 25.4.

# ROUGH-IN

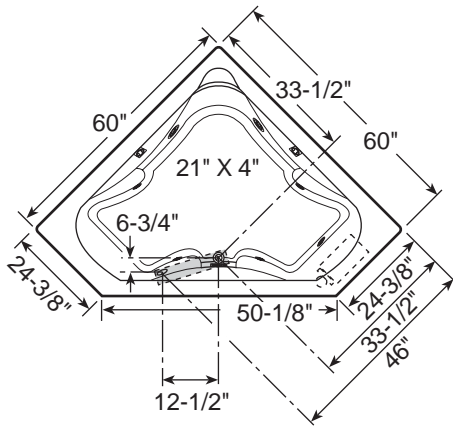

(Right hand shown. Left hand is a mirror image)

**ESPREE 6060 WITHOUT SKIRT**

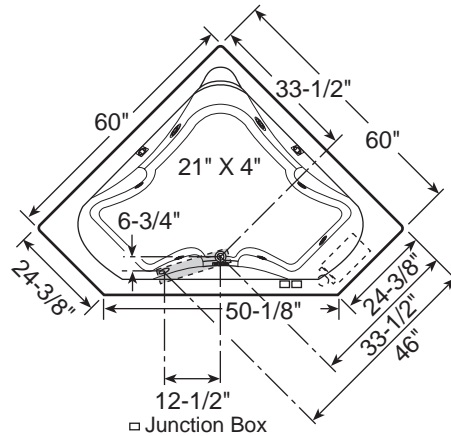

(Right hand only as shown)

**ESPREE 6060 WITH INTEGRAL SKIRT**

- Note: 1. The overall dimensions are nominal with a tolerance of +0 and -1/4".  
 1. Measurements inside each unit represent cutout in floor to allow for drain/overflow.  
 2. All measurements are in inches. To convert to millimeters, multiply inches by 25.4.

**6060 CUTOUT**

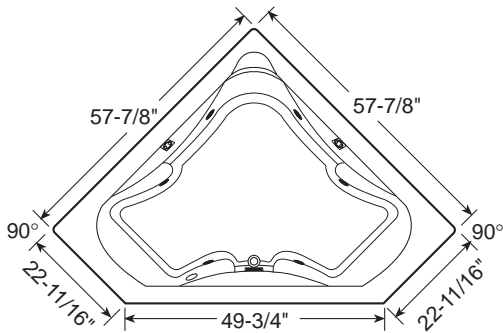

**ESPREE 6060 WITHOUT SKIRT**

**6032 CUTOUT**

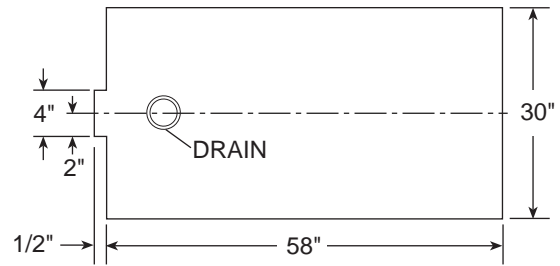

**ESPREE 6032 DROP-IN CUTOUT**



# INSTALLATION

## Framing and Support

The drain/overflow of the bath extends below the bottom of the bath. Note that this requires a cutout in the floor.

**The floor structure beneath the bath must be able to support a total weight of bath, water, and bather. Refer to the table under total weight for your model.** The unit must be supported from the bottom of the bath and **not** from the bath rim or tile flange. If the subfloor is level, no other preparation is necessary. You can proceed to install the bath. If the subfloor is not level, you **MUST** level the entire surface prior to installing the bath. The use of materials that shim or provide a level installation are allowed provided the method used will insure a level bath that is supported from the bottom. Materials that may be used are a floor leveling compound, mortar, plaster or minimal expansion structural foam having a density of a minimum of 5 lbs./cubic ft.; however the bath must remain level in order for it to drain properly and the foam feet must make full contact with the leveling material. Both sides of a joint or splice of subfloor should be level to each other. **When attaching baths with flanges to stud wall, use shims to fill any gaps between the bath flange and studs.**

The rim of the bath is not designed to support weight. If finish material is to overlap or contact the bath, the added weight must be fully self-supporting.

**The protective film liner inside the bath is used to prevent damage to the finish from shoes, tools, etc. during installation. Before installation, remove liner to inspect for any defects, reapply and do not remove until final cleanup.**

**Important: If a skirt is to be used, it must be installed at the time of unit installation – refer to skirt installation instructions.** Install optional trim parts when all installation has been completed.

### TYPICAL INSTALLATIONS

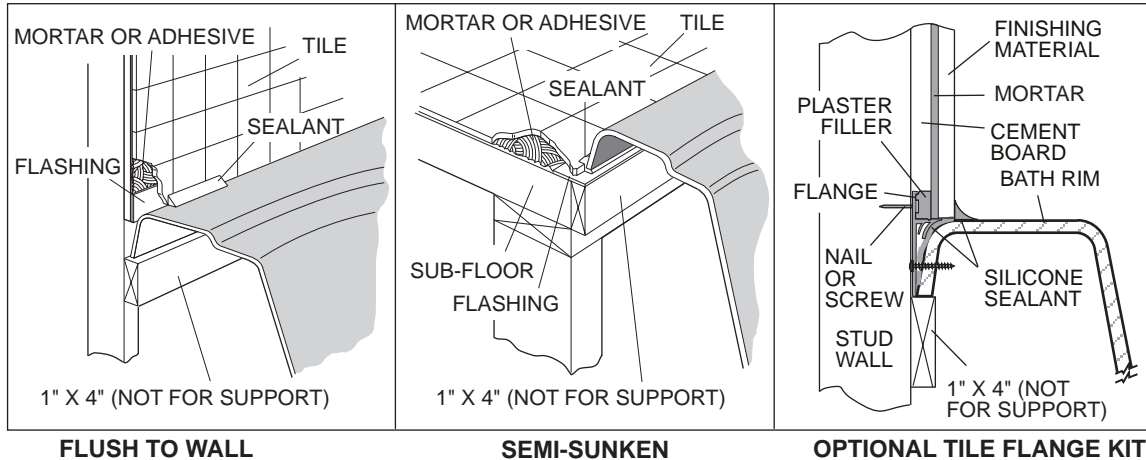

### TYPICAL FLANGE MOUNTING DETAIL

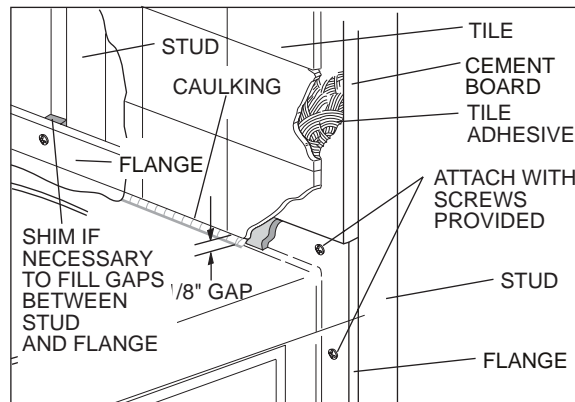

# INSTALLATION

## Service Access

For partially or fully sunken installations, allow for access to service connections. It is the installer's responsibility to provide sufficient service access. The recommended minimum dimensions allowable for service to the bath are shown in the "Service Access" illustration.

Provide adequate area around unit for air circulation for cooling the motor and to supply sufficient air to the jets. Do not insulate this area or around motor.

## Service Access with Skirt

An optional skirt fits along the side of the bath for above-floor installations and is also an access panel for servicing. Allow a space of at least 8 inches away from the bath for skirt removal.

The skirt is designed to accommodate the added height of the tile, linoleum, or other floor coverings up to 1-1/4 inches above the floor, and will be flush with the floor when installed.

More detailed instructions on skirt installation are provided with the optional skirt assembly.

## SERVICE ACCESS (CORNER BATH WITHOUT SKIRT)

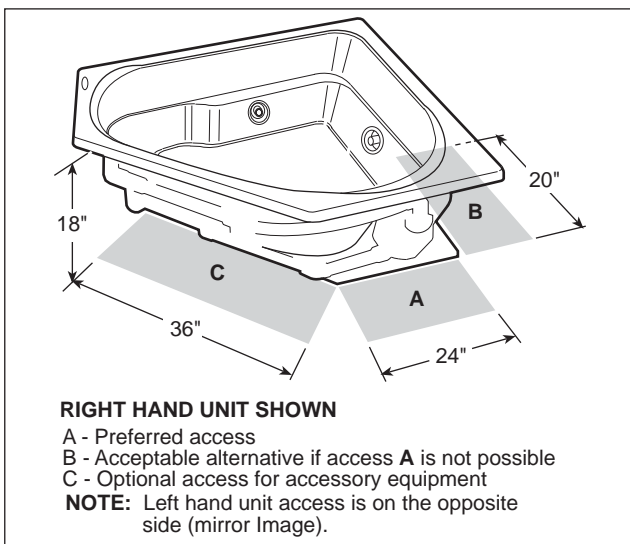

## Service Access with Integral Skirt

Service access is through the removable skirt panels.

## SERVICE ACCESS (WITH INTEGRAL SKIRT)

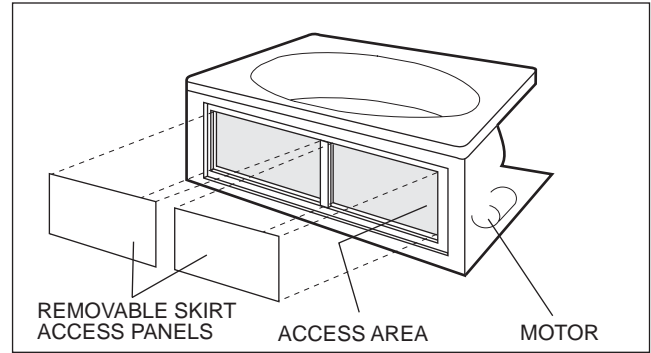

## Reinstalling Panel

Hold at an angle to the skirt and insert clip under edge of skirt opening. Bow the panel outward and insert clip on other side.

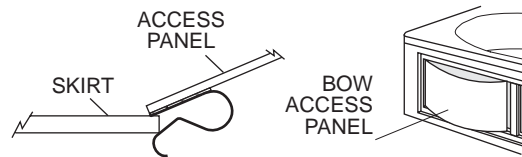

Or slide clips over bottom lip of skirt opening and tilt up until velcro tabs make contact.

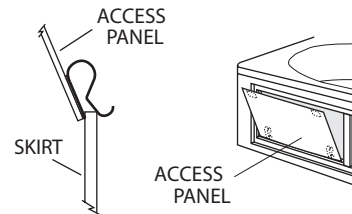

## SERVICE ACCESS (WITHOUT SKIRT)

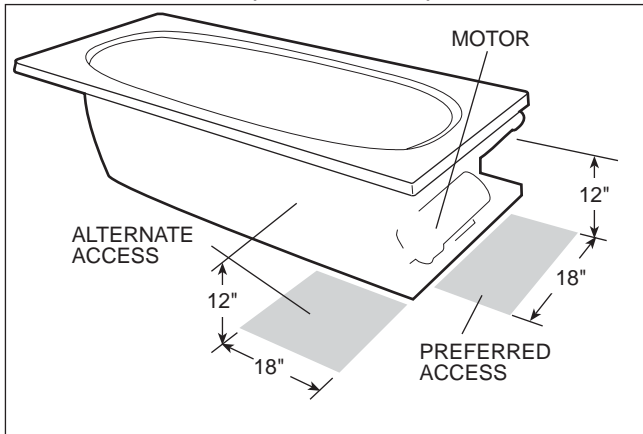

# INSTALLATION

## Electrical Connections

A separate circuit, which must be protected by a Ground Fault Circuit Interrupter (GFCI), is required. Install a duplex outlet to the studwall underneath the bathtub, at least 4 inches above the floor. The duplex outlet is not provided. Because these units are manufactured with a safe, convenient Magic Touch whirlpool ON/OFF switch on the bath itself, no remote switch or timer is necessary. If an optional timer is desired, one is available from Jacuzzi Whirlpool Bath for 115 VAC operation.

**DANGER: RISK OF ELECTRIC SHOCK. Connect only to a circuit protected by a Ground Fault Circuit Interrupter.**

**⚠ CAUTION: Operating the motor/pump without enough water in the bath can cause leaking and permanent damage to the pump. Before power is applied to the installation, make sure the switch is in the OFF position to avoid pump damage.**

### ELECTRICAL CONNECTION (FOR SIDE/END DRAIN BATHS)

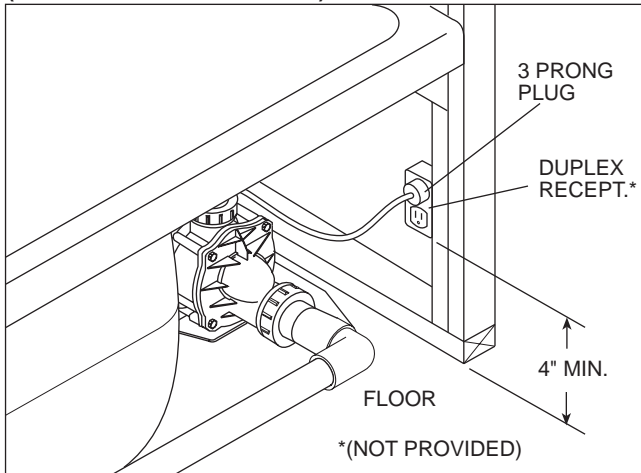

### ELECTRICAL CONNECTION (FOR MOTOR PUMP ON DRAIN SIDE)

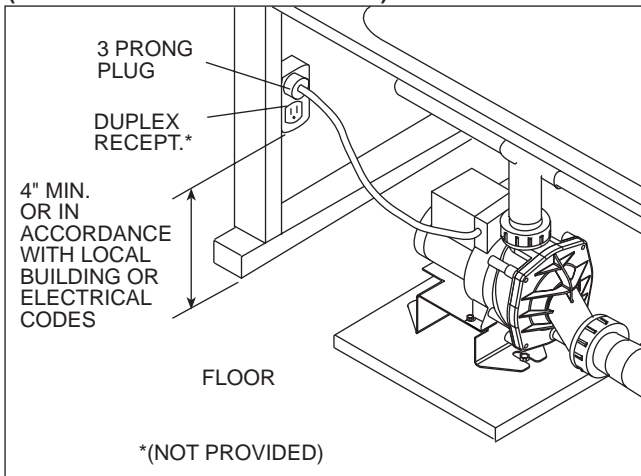

## Electrical Connection 6060 With Heater

On the 6060 with integral skirt, one junction box has been provided for the pump/motor and one for the heater. To access, remove skirt access panel. See top view for location.

A separate GFCI protected outlet (not provided) is required for pump/motor and is to be installed in the junction box. The junction box is to be hard wired. The motor is bonded to the junction box at the factory.

Install a separate 120 VAC 15 AMP dedicated circuit with GFCI protection. With a #8 solid copper wire, bond the heater to the house electrical panel or approved local bond. A bonding lug is provided on the heater.

At initial start-up and before each use thereafter with power ON, push the GFCI test button. The reset button should pop out. Push this button in to reset. If the interrupter fails to operate in this manner, there is a ground current flowing or a device malfunction, indicating the possibility of electrical shock. **Turn off power and do not use the bath until the source of the problem has been identified and corrected.**

### 60x60 WITH INTEGRAL SKIRT MOTOR JUNCTION BOX

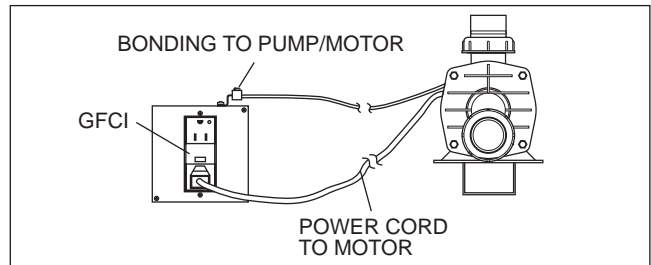

### 60x60 WITH INTEGRAL SKIRT RAPIDHEAT JUNCTION BOX

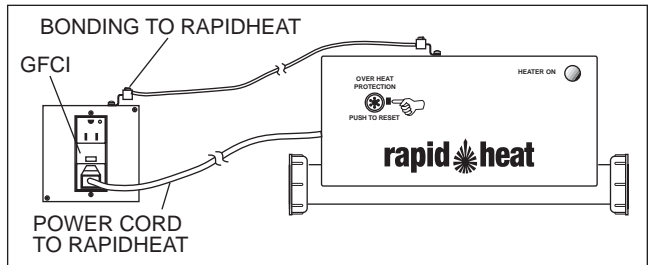

# INSTALLATION

## Drain Information

A drain/overflow assembly (sold separately) must be installed on the bath, water tested, and connected to the sanitary system of the house. After opening the carton, inspect for damage and verify that the kit is of the proper finish. In the Jacuzzi Whirlpool Bath drain/overflow kit, note that the waste flange, strainer, overflow cover and cover screws are packaged in a separate package within the kit to protect the trim finish. Follow the installation instructions provided with the drain/overflow kit. After the drain is fully installed, test for proper drainage. If the unit does not drain properly, rectify this condition before proceeding with the installation. Jacuzzi Whirlpool Bath is not responsible for removal and or reinstallation costs.

**NOTE: Watertight installation of the drain is the installer's responsibility. Drain leakage is excluded from the Jacuzzi Whirlpool Bath warranty of this product.**

## Plumbing

Pump, jets, and suction fittings for the whirlpool system are factory plumbed in schedule 40 PVC piping.

All Jacuzzi Whirlpool Bath products are factory tested for proper operation and watertight connections prior to shipping. If leaks are detected, notify your Jacuzzi Whirlpool Bath Dealer. Do not install the unit.

## Water Supply

Consult local authorities for plumbing code requirements in your area.

**IMPORTANT: Proper installation of the fill spout plumbing and compliance with local codes are the responsibility of the installer. Jacuzzi Whirlpool Bath does not warrant connections of water supply fittings and piping, fill systems, or drain/overflow systems. Nor is it responsible for damage to the bath which occurs during installation.**



**CAUTION: A nonflammable protective barrier must be placed between soldering work and bath unit to prevent damage to the bath.**

## Clean-Up After Installation

To avoid dulling and scratching the surface of the bath, never use abrasive cleaners. A mild liquid detergent and warm water will clean soiled surfaces.

Remove spilled plaster with a wood or plastic edge. Metal tools will scratch the surface. Spots left by plaster or grout can be removed if lightly rubbed with detergent on a damp cloth or sponge.

Paint, tar, or other difficult stains can be removed with paint thinner, turpentine, or isopropyl alcohol (rubbing alcohol).

Minor scratches which do not penetrate the color finish can be removed by lightly sanding with 600-grit wet/dry sandpaper. You can restore the glossy finish to the acrylic surface of the bath with a special compound, Meguiar's #10 Mirror Glaze. If that is not available, use automotive rubbing compound followed by an application of automotive paste wax.

Major scratches and gouges which penetrate the acrylic surface will require refinishing. Ask your Jacuzzi Whirlpool Bath dealer for special instructions.

# OPERATION

All baths manufactured by Jacuzzi Whirlpool Bath are designed for "fill and drain," which means the bath should be drained after each use and filled with fresh water by the next bather. This is a health precaution, as these baths are not designed to hold water continuously like pools or spas. If you want a unit designed to continuously hold water, see your Jacuzzi Whirlpool Bath dealer for the complete line of whirlpool spas available.

Once the bath is installed, remove any residue or foreign materials left over from construction. Use turpentine or paint thinner to remove stubborn stains, paint or tar. Other dirt can be cleaned off with a mild liquid detergent on a damp cloth. Scrape off plaster with a wooden or plastic edge; **do not use metal scrapers, wire brushes or other metal tools, as they will damage the bath's surface.**

## Water Level

Close the drain and fill the bath until water is at least 2" above the highest jet (see water line indicated in the illustration). **Do not turn on the whirlpool system at any time if the jets are not completely immersed in water.** Running the whirlpool system when there is insufficient water in the bath could result in water spraying outside the bath area. Running the whirlpool system without water will damage the recirculating pump.

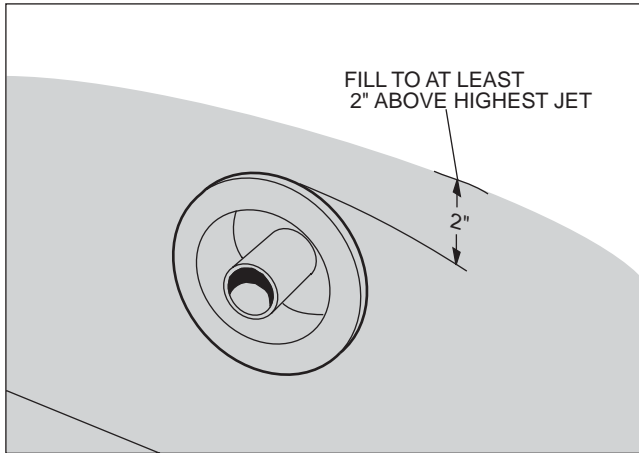

## TYPICAL BATH FITTINGS

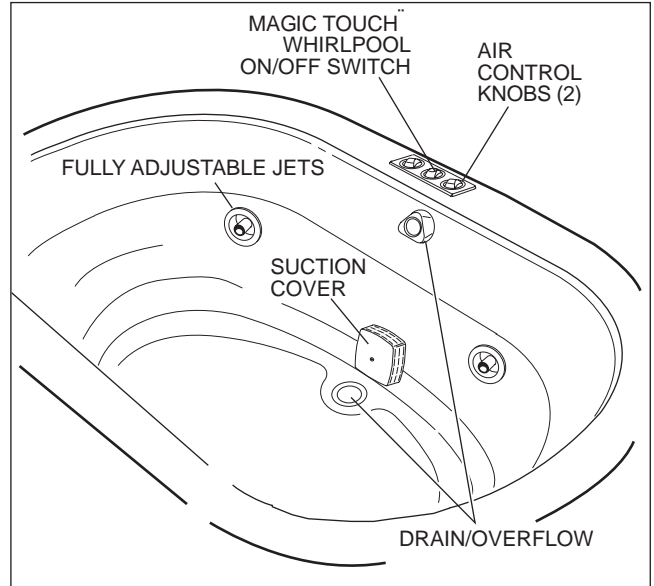

## Magic Touch® Whirlpool Switch

The Magic Touch whirlpool ON/OFF switch, conveniently located on the bath, allows you to turn the whirlpool system on and off while in the bath. Simply push down on the switch button to turn on the whirlpool system. To turn the system off, push down on the button again.

If your bath has an optional Jacuzzi Whirlpool Bath wall mounted timer, set it for the amount of time you wish the whirlpool to operate. Note: when you desire less than 10 minutes of whirlpool action, it is necessary to turn the timer knob clockwise past the number 10 and then back to the desired amount. If the whirlpool action does not begin when the timer is correctly set, it is necessary to push the Magic Touch switch button.

## MAGIC TOUCH SWITCH

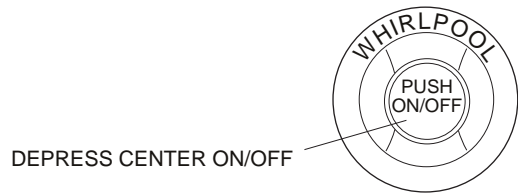

# OPERATION

## RapidHeat Operation

Once the heater is installed and the whirlpool pump is operating, the heating function is totally automatic. The heater will help maintain the temperature of the water in the bath.

## Vacuum Switch

The heater is equipped with a preset vacuum switch which will not allow the heater to turn ON if the pump is not running with water flowing through the whirlpool system.

## High-Limit Switch

The heater includes an exclusive High-Limit switch. This safety circuit will not false trip from hot tap water. It will only turn off the heater if the thermostat fails. To reset, press the button. If the high-limit trips frequently, contact your dealer.

## Heater On Indicator

The light will be illuminated any time the heater is operating

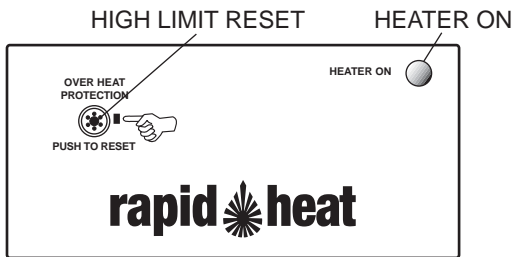

## Controlling Whirlpool Action

The whirlpool action in your bath is influenced by three factors – direction of flow, force of water, and force of air. All baths manufactured by Jacuzzi Whirlpool Bath are equipped with fully adjustable PowerPro® jets, which are adjustable for all three factors. Some baths have additional directionally adjustable jets which can be adjusted for direction and flow of air only.

**Direction:** To change the direction of the water flow, swivel the jet nozzle to the desired angle. The jets can be directed individually toward any location on your body to provide a hydromassage. The jets can also be adjusted so that they all point in the same direction (clockwise or counterclockwise) to circulate the water in a circular motion around the bath, causing a total whirlpool effect.

**Water Force:** The high volume, fully adjustable jets can be adjusted to control the force of the water coming into the bath. For robust action, increase the force of the flow by rotating the jet handles to the left (counterclockwise). For a more gentle effect, rotate the handles to the right (clockwise). **Never run the whirlpool system with all the jets closed.**

**Force of Air:** Two knobs located on the bath serve as controls for the air induction system. The intensity of the hydromassage whirlpool action is determined by the amount of air inducted into the water. As the amount of air is increased, the hydromassage action increases. For maximum air induction, rotate the control knobs fully counterclockwise to the largest circles. For fewer air bubbles, decrease the amount of air induction by rotating the control knob clockwise. When the knobs are turned to the smallest circles, only water is being circulated.

## JETS

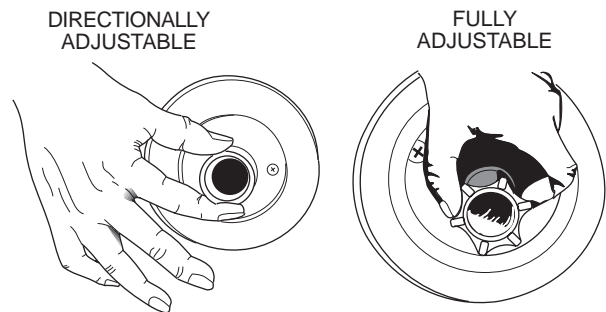

## Back Massage Jet - Flow Adjustment

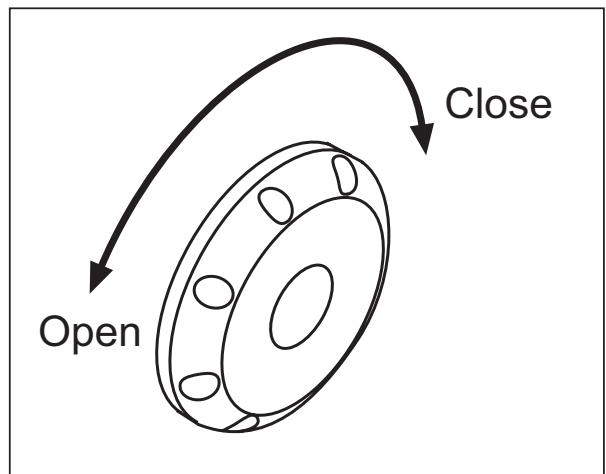

## AIR INDUCTION CONTROLS

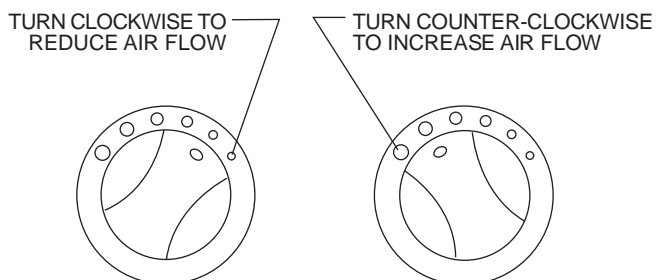

# MAINTENANCE

## Cleaning the Bath

To clean your bath, simply use a mild, nonabrasive liquid detergent solution. You can protect and restore the gloss to a dulled acrylic surface by applying Meguiar's #10 Mirror Glaze, a product specifically designed for use on acrylic finishes. If Meguiar's is not available, an acrylic polish of equal quality or automotive paste wax is acceptable.

**Never use abrasive household cleaners on any Jacuzzi Whirlpool Bath product.**

## Repairs to the Surface

Minor scratches which do not penetrate the color finish can be removed by lightly sanding with 600-grit wet/dry sandpaper. Restore the gloss using Meguiar's Mirror Glaze or automotive paste wax.

Major scratches and gouges which penetrate the acrylic surface will require refinishing. Ask your Jacuzzi Whirlpool Bath dealer for special instructions.

## Purging the Whirlpool System

**NOTE: THE WHIRLPOOL SYSTEM SHOULD BE PURGED AT LEAST TWICE A MONTH**

To remove accumulations of bath residue from the whirlpool system, it is recommended that a whirlpool bath be purged at least twice a month. For best results, however, we recommend that you purge your whirlpool bath after each use using our exclusive two-part plumbing system cleaner made specifically for whirlpool baths. Systems Clean™ is available through an authorized Jacuzzi Whirlpool Bath Distributor or by calling us direct at 1-800-288-4002. Instructions for use: Immediately after bathing and exiting the whirlpool bath, leave the bath water in the tub and add hot water, if necessary, so the water is at least 2" above the highest jet. Turn on the unit without the aerator. Pour the contents of the Systems Clean Packet 1 (taking care not to get the material on yourself) into the bath near the intake for the circulation pump. Repeat same process with Systems Clean Packet 2. **It is important to use Packet 1 before Packet 2 to avoid a strong odor.** Run the bath for 5 to 10 minutes. Drain completely and rinse any residue.

If you have followed the standard purging instructions above and still have an excess accumulation of bath residue and desire an alternative cleaning mechanism, we recommend **SUPER SYSTEMS CLEAN PLUS** manufactured by Stearns Packaging to rectify this condition. This may be obtained by contacting us at 1-800-288-4002. It is recommended that you follow the instructions provided by the manufacturer with the product. Repeated use may be necessary. **SUPER SYSTEMS CLEAN PLUS** does not replace the necessity to regularly purge your whirlpool system with Systems Clean as recommended.

(For additional information about water content, contact us for a copy of the Jacuzzi Water Quality Primer.)

## Lamp

An optional lamp kit is available from your Jacuzzi Whirlpool Bath dealer for installation on your bath.

When the bulb burns out, replace it from the **back** of the lamp fitting, on the underside of the shell, by pulling out the bulb receptacle. Replacement bulbs (12V, 7W) are available from your Jacuzzi Whirlpool Bath dealer.

## Bath Additives

**NOTE: DO NOT USE OIL OR OIL BASED BATH ADDITIVES.**

If you want to use any kind of bath additive, use only a small amount of low-foaming powder or crystal substance; the whirlpool action intensifies the foaming properties of soaps.

The use of certain bath oils, bubble baths and bath additives may increase the level of accumulations of bath residue in the whirlpool system. If excess accumulations persist, you should discontinue use of these products.

## Suction Cover/Strainer Maintenance

Clean the suction cover/strainer of hair and debris when necessary. To do this, remove the center screw and detach the square cover. Clean the cover by back-flushing debris from the holes. Replace the suction cover immediately after cleaning. When reinstalling, orient the cover/strainer with the small notch at the bottom. The gasket must be inserted into the groove of the cover/strainer before reinstalling onto the suction fitting.

**CAUTION: Keep hair a minimum of 6 inches away from the suction fitting at all times when the whirlpool system is operating. Hair longer than shoulder length should be secured close to the head, or a bathing cap should be worn. Do not operate the whirlpool system with the suction cover removed! It is a safety device and must always be in place on the suction fitting to minimize the potential hazard of hair and body entrapment.**

### SUCTION COVER/STRAINER ASSEMBLY

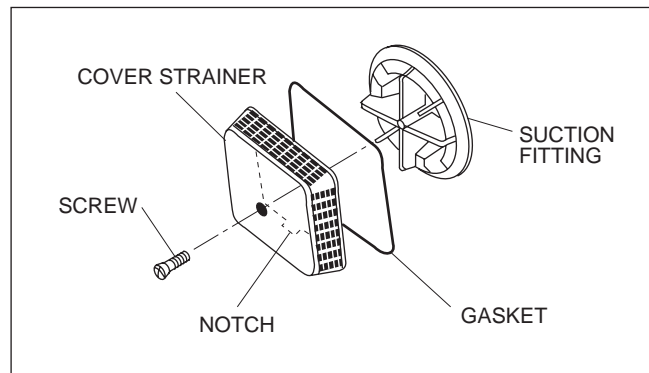

### LIGHT BULB REPLACEMENT

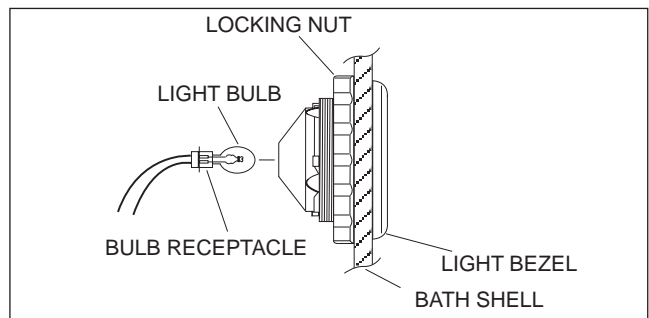

## General Whirlpool Bath Troubleshooting Guide

PROBLEM	PROBABLE CAUSES	REMEDY
Pump/Motor does not start.	No power to pump/motor.	Reset GFCI.
	Pump/motor not plugged in.	Insert plug fully into outlet.
	Magic Touch switch - air tube not connected to switch or to air switch on pump/motor.	Reconnect tube to Magic Touch switch or to air switch pump/motor.
	Pump/motor faulty.	Replace pump/motor assembly.
Pump/Motor operates but no fully adjustable jets are functioning.	Jets are closed.	Open jets by rotate counterclockwise.
	Suction cover may be clogged.	With motor turned off, remove safety cover and remove any debris. <b>Replace suction cover before operating.</b>
	Air entrapment.	Ensure that water level is at least 2" above the highest jet.
Pump/Motor operates but air is not injected into water.	Air valves closed.	Open air control valves.
Pump/motor does not shutoff.	Magic Touch switch - air tube not connected to switch or to air switch on pump/motor.	Reconnect tube to Magic Touch switch or to air switch pump/motor.
	If a wall timer is used, the timer is defective	Replace timer.
Water leakage from pump unions.	Overtightened, O-ring may be pinched or improperly seated, under tightened.	Untighten unions check and reseal O-ring. If O-ring has been pinched out of shape, replace (refer to Service Support number below). When tightening union nuts, <b>hand tighten only</b> .
Pump/motor shuts off by itself or with wall timer, before set time elapses.	Motor thermal protection has deactivated pump/motor due to overheating. (Supply voltage low.)	Let motor cool; thermal protection will reset. Check for proper ventilation. (Check supply voltage.)
	GFCI tripped.	Reset GFCI. If it continues to trip do not use this unit. Disconnect the unit and have the problem corrected by a licensed electrician before using.
	Inadequate supply wiring.	Consult a licensed electrician to correct wiring to unit.

Note: If unit is within the warranty period, contact Jacuzzi Whirlpool Bath Service Support at (866) 905-2289 with bath's serial number before work is started. The Serial Number is located on the Specification/Serial Number Plate. See page 13.



## Authorized Service

If you need a referral for a service company near you, or need assistance with operation or maintenance related questions, please call our Service Support Department at 1-866-905-2289. For service agent listing, visit our web site at <http://www.jacuzzi.com/>. To find the service agent listings, click on "For The Trade". Then click on Electrical/Mechanical Service Agents. Depending on the problem, click on "Electrical/Mechanical Repairs" or "Finish, Surface or Shell-Related Problems".

When requesting service or technical assistance please have available both the model and serial number of your unit. This information can be obtained from the product registration card provided with your unit. If the card has been misplaced, this information can be obtained from the specification/serial number label on the unit itself (for location of specification/serial number label see below).

### BATH PRODUCTS

Whirlpool baths: The label is located on the wall of the bath near the pump/motor.

Non-jetted baths: The label is located next to the overflow.

SPECIFICATION/SERIAL NUMBER PLATE

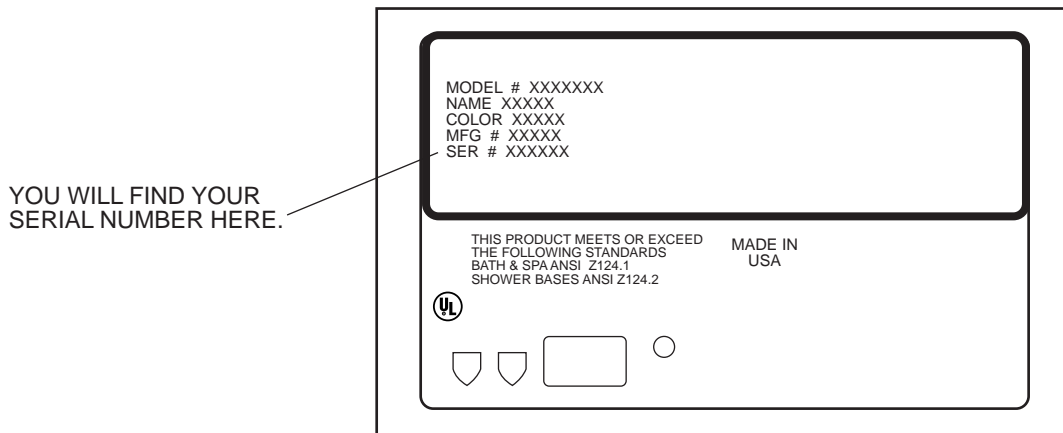

# REPAIR PARTS

**NOTE:** When a part number has 3 Xs, substitute the appropriate color code for the Xs:

- 940 White
- 914 Almond
- 969 Oyster

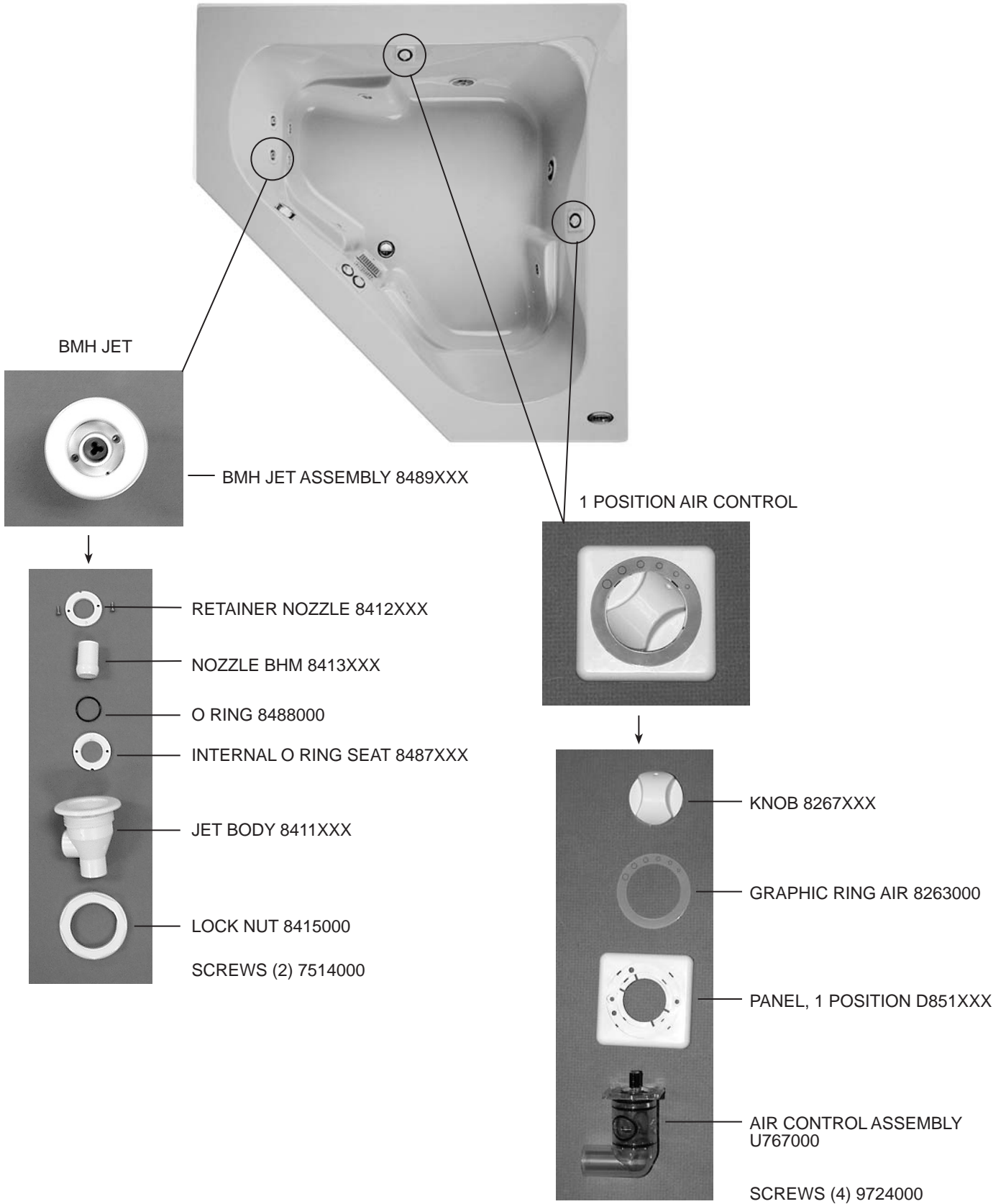

# REPAIR PARTS



2 POSITION CONTROLLER  
(AIR & PUMP/MOTOR ON/OFF)

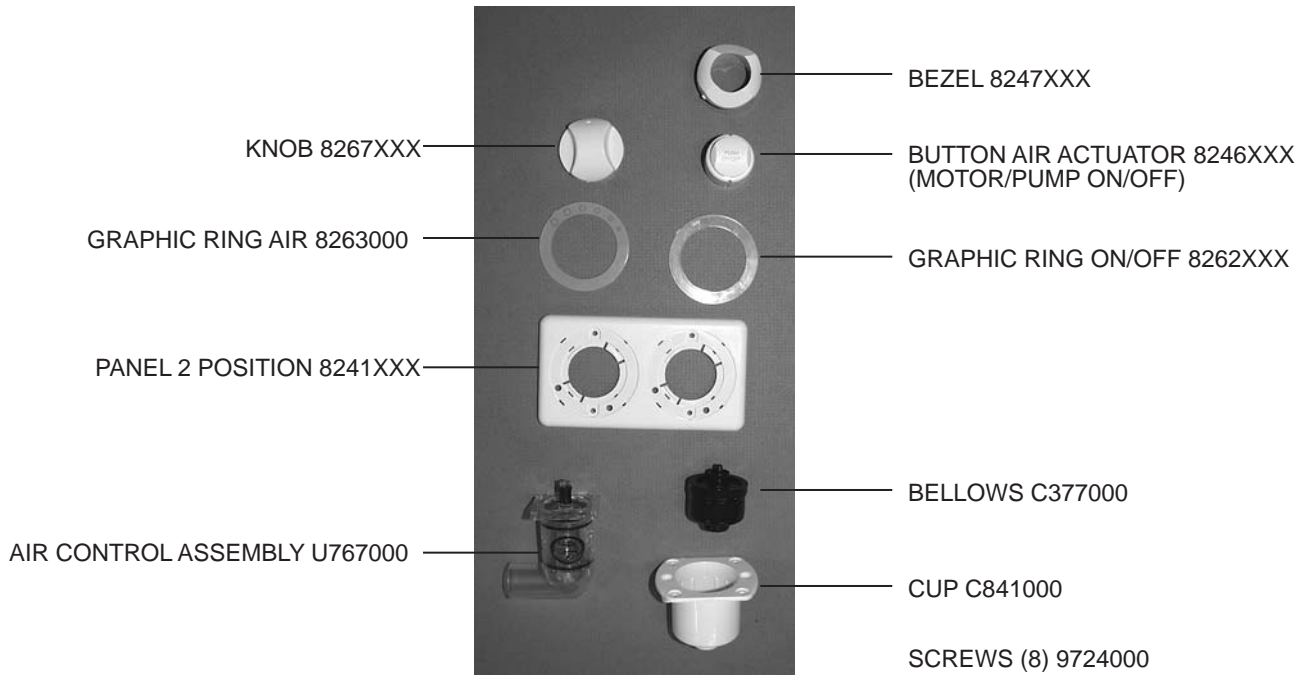

# REPAIR PARTS



HTC JET

SUCTION ASSEMBLY



HTC ASSEMBLY B785XXX

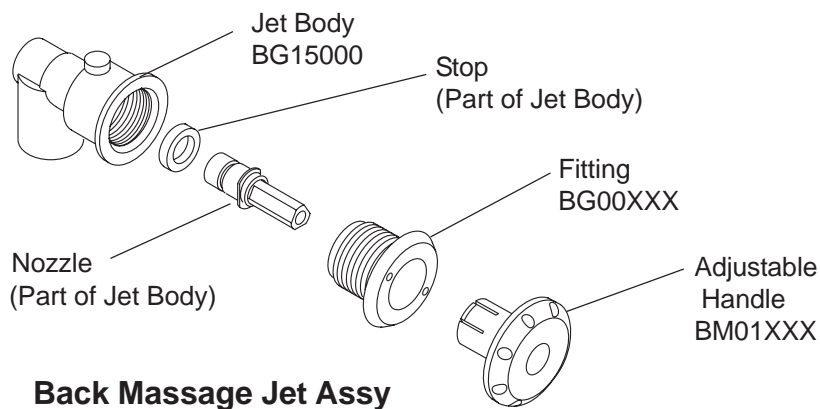
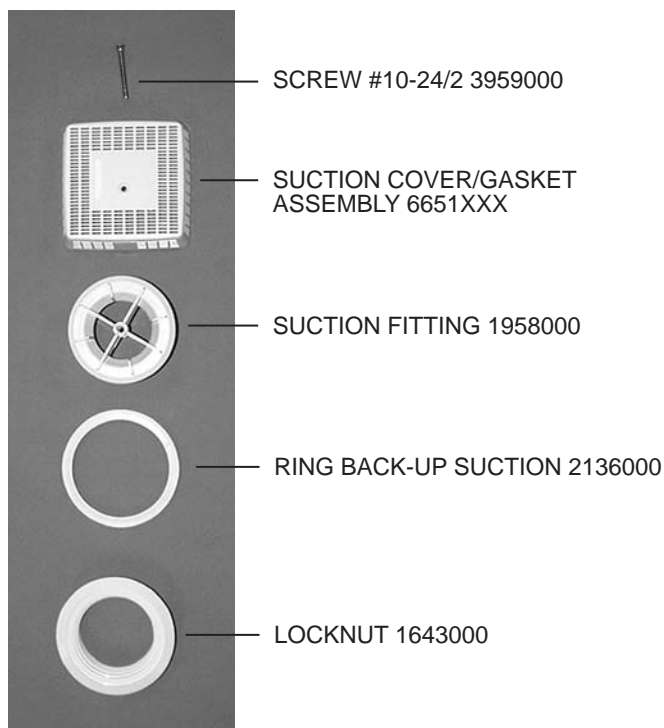
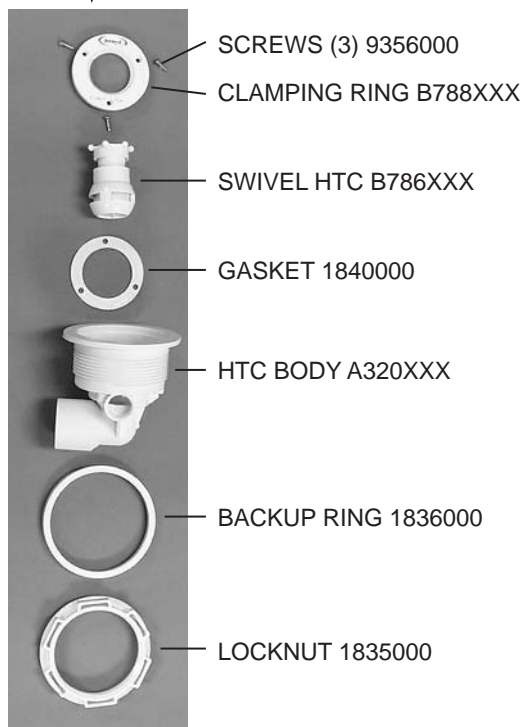

# REPAIR PARTS

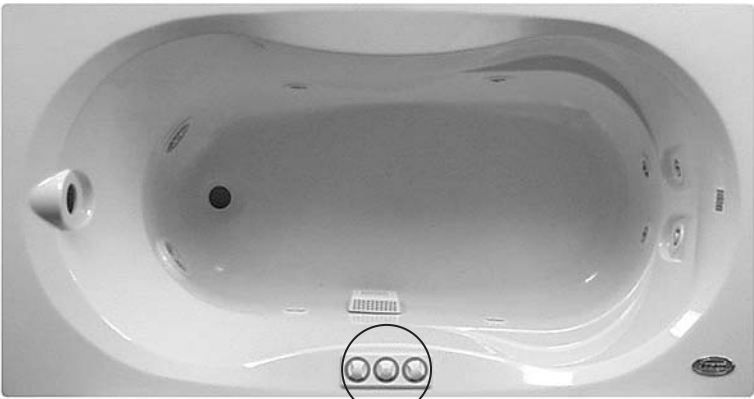

3 POSITION PANEL

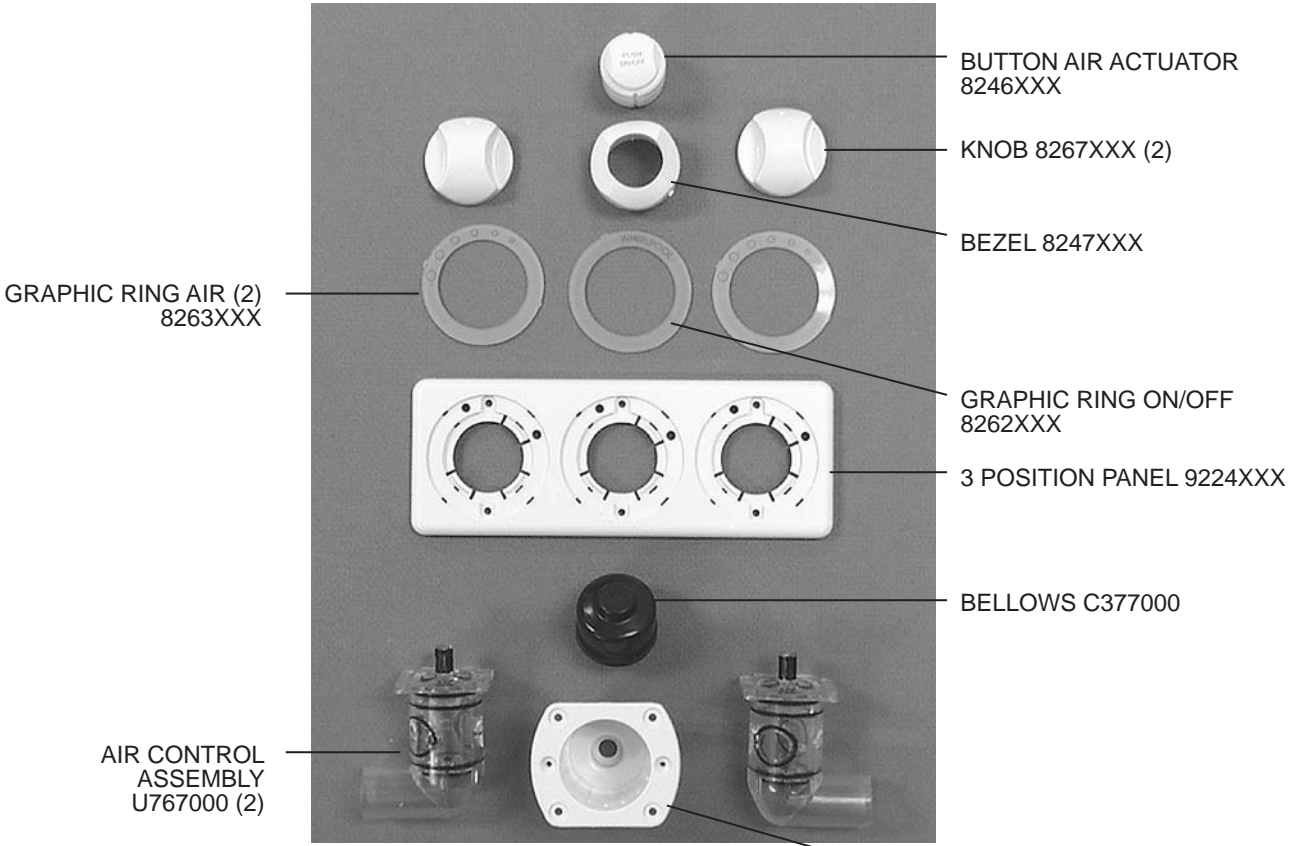

GRAPHIC RING AIR (2)  
8263XXX

BUTTON AIR ACTUATOR  
8246XXX

KNOB 8267XXX (2)

BEZEL 8247XXX

GRAPHIC RING ON/OFF  
8262XXX

3 POSITION PANEL 9224XXX

BELLOWS C377000

AIR CONTROL  
ASSEMBLY  
U767000 (2)

SCREWS (10) 9724000

CUP C841000

# REPAIR PARTS

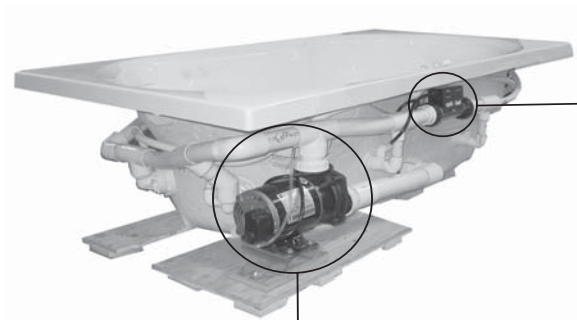

**RAPIDHEAT REPAIR HEATER**  
 DISCHARGE SIDE U394000 (SHOWN)  
 UNION GASKETS (2) Y671000  
 UNIONS (2) Y670000

SUCTION SIDE S749000  
 UNION GASKETS (2) G947000  
 UNIONS (2) T180000

NOTE: Suction heater components and Discharge heater components are not interchangeable.

**MOTOR/PUMP ASSEMBLY**  
 7.0 A 115V 60Hz Y660000

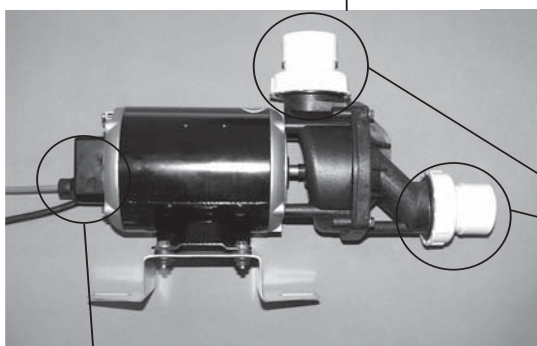

**HEATER BLANK**



DISCHARGE SIDE BF67000  
 UNION GASKETS (2) Y671000  
 UNIONS (2) Y670000

SUCTION SIDE BF68000  
 UNION GASKETS (2) G947000  
 UNIONS (2) T180000

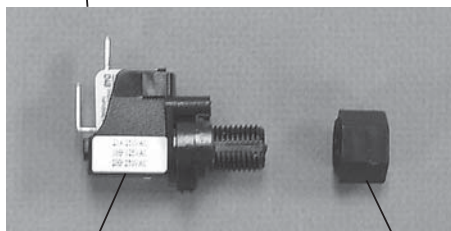

**SWITCH AIR ACTUATED** 7396000

**STRAIN RELIEF AIR SWITCH** N186000

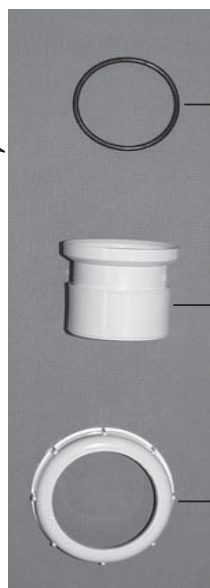

**UNION REPAIR KIT 9250000:**

O-RING 9231000

ADAPTER UNION 9234000

NUT UNION 9233000

**PRODUCT SPECIFICATIONS ARE SUBJECT TO CHANGE WITHOUT NOTICE.**

**USE INSTALLATION INSTRUCTIONS SUPPLIED WITH PRODUCT.**

Jacuzzi Whirlpool Bath has obtained applicable code (standards) listings generally available on a national basis for products of this type. It is the responsibility of the installer/owner to determine specific local code compliance prior to installation of the product. Jacuzzi Whirlpool Bath makes no representation or warranty regarding, and will not be responsible for any code compliance.

## JACUZZI WHIRLPOOL BATH

P.O. Box 702168, Dallas, TX 75370-2168

**Service Support:** (866) 905-2289

©2003 Jacuzzi Whirlpool Bath U961000F 12/04



Printed on Recycled Paper

# Jacuzzi Whirlpool Bath Limited Warranty

## Espree Series Bath Product

### WARRANTY COVERAGE

Jacuzzi Whirlpool Bath (the "Company") offers the following express limited warranty to the original purchaser of any Jacuzzi Whirlpool Bath Espree Series Bath Product ("unit") who purchases the product for personal or single family use ("user"). The Company will repair or replace, at its option, the unit or its equipment in accordance with the following terms and conditions.

#### ONE YEAR LIMITED WARRANTY ON BATHS

Our limited warranty on Espree Series Bath products is for one (1) year. Our warranty covers the unit and factory-installed components against defects in material or workmanship. Warranty coverage begins on the date the unit was originally purchased by the user.

#### FIVE YEAR (PARTS ONLY) LIMITED WARRANTY ON PUMP AND MOTOR

Our limited warranty on the pump and motor is for five (5) years for parts only. Warranty coverage begins on the date the unit was originally purchased by the user.

#### NINETY DAY (PARTS ONLY) LIMITED WARRANTY ON OPTIONS AND ACCESSORIES

Our limited warranty on options and accessories manufactured by the Company is for ninety (90) days for parts only. Our warranty covers options and accessories manufactured by the Company (e.g., fill spout kits, trim kits, skirts) against defects of material or workmanship. Warranty coverage begins on the date the option or accessory was originally purchased by the user.

### WARRANTY LIMITATIONS

Our limited warranty does not cover defects, damage, or failure caused by the common carrier, installer, user, or other person, or resulting from, without limitation, any of the following: careless handling (lifting unit by plumbing, abrading finish, etc.) including its own negligence; modification of any type for any reason (including modification to meet local codes); improper installation (including installation not in accordance with instructions and specifications provided with the unit); connections supplied by the installer of the equipment; improper voltage supply or unauthorized electrical modification; misuse; incorrect operation, or lack of proper routine maintenance; operation of the unit without specified minimum amount of water or at inappropriate water temperature; use of abrasive or improper cleaners; or acts of God, such as lightning, floods, earthquakes, etc.

In addition, THE COMPANY WILL NOT BE RESPONSIBLE FOR INCIDENTAL OR CONSEQUENTIAL DAMAGES or losses arising from any cause (e.g., water damage to carpet, ceiling, loss of use, etc.) including its own negligence; damages to, respecting, or resulting from: plated parts when pool and/or spa chemicals are used in the unit; optional bath equipment not manufactured by the Company but supplied by Dealer, installer or the Company; the unit's prior usage as an operational display; or defects that should have been discovered before installation. This limited warranty does not include: labor, transportation, or other costs incurred in the removal and/or reinstallation of the original unit and/or installation of a replacement unit; any costs relating to obtaining access for repair; or loss of use damage, including loss of sales, profit or business advantage of any kind under any circumstances. Bath units are excluded from any warranty coverage if any addition, deletion, or modification of any kind whatsoever has been made to the unit (or to any component).

Warranty coverage is provided in the United States of America and Canada.

### EXCLUSION OF IMPLIED WARRANTIES

IMPLIED WARRANTIES OF MERCHANTABILITY AND FITNESS FOR A PARTICULAR PURPOSE ARE DISCLAIMED ALTOGETHER OR TO THE FULL EXTENT ALLOWED BY LAW.

NOTICE: This warranty gives you specific legal rights, and you may also have other rights which vary from state to state. There are no warranties applicable to Jacuzzi Whirlpool Bath products except as expressly stated herein or as implied by applicable state and federal laws. The Company will not be responsible for any statements or representations made in any form that go beyond, are broader than or are inconsistent with any authorized literature or specifications furnished by the Company.

Some states do not allow limitations on how long an implied warranty lasts, or the exclusion or limitation of incidental or consequential damages, so the above limitations and exclusions may not apply to you.

### RETURN OF WARRANTY CARD

The attached Warranty Registration Card MUST be filled out by the purchaser within thirty (30) days from purchase and mailed to Jacuzzi Whirlpool Bath in order for this warranty to become effective.

---

Jacuzzi Whirlpool Bath  
P.O. Box 702168  
Dallas, TX 75370-2168



## RESPONSIBILITIES OF OTHERS

Inspecting the unit prior to installation is the responsibility of the installer or building contractor who acts on behalf of the user. They are responsible for ensuring the unit is free of defect or damage. Notices are placed on and in the unit and on the shipping carton advising the installer of this responsibility. In the event of a problem, the unit must not be installed. The Company is not responsible for failures or damage that could have been discovered, repaired, or avoided by proper inspection and testing prior to installation.

Damage occurring in transit is the responsibility of the carrier. The user or installer MUST open the crate and inspect the unit for damage when it is delivered. If damage is discovered, it must be reported immediately to the seller and the carrier in writing, and an inspection requested. Failure of the carrier to respond should be reported to the seller and the carrier. Your freight claims should be filed promptly thereafter.

It is the responsibility of the installer, building contractor, or user to provide access for service. The Company is not responsible for any costs relating to obtaining access for repair. The user shall bear such costs and, if appropriate, must seek recovery from the installer.

Damage occurring to the unit during installation is the responsibility of the installer and/or building contractor and damage occurring thereafter is the responsibility of the user.

Failure of any optional equipment is the sole responsibility of the equipment manufacturer. (Options and accessories manufactured by the Company are warranted for ninety (90) days from the original date of purchase for parts only.)

The Distributor or Dealer is responsible for knowing local code requirements and notifying the installing contractor and/or user of these requirements at the time of purchase. The Company is not responsible for costs to modify any product to obtain any code approval, such as city, county, or state building codes in U.S.A.

## WARRANTY SERVICE

For the customer's benefit, the Company maintains a list of independent service personnel to perform required warranty service repairs. Such firms are not agents or representatives of the Company and cannot bind the Company by words or conduct.

The Company will provide the warranty service described above when the following conditions have been met: the failure is of the nature or type covered by the warranty; the user has informed an Authorized Jacuzzi Whirlpool Bath Service Agent or Warranty Service Department Representative of the nature of the problem during the warranty period; conclusive evidence (e.g., proof of purchase or installation) is provided to the foregoing by the user proving that the failure occurred or was discovered within the warranty period; an authorized independent service person or Company representative has been permitted to inspect the unit during regular business hours within a reasonable time after the problem was reported by the user.

In order to obtain warranty service, consult your local telephone book for the location of the nearest Jacuzzi Whirlpool Bath Authorized Service Agent. Describe the problem and the Authorized Service Agent will inspect the unit and provide the required warranty service.

If you are unable to contact a Jacuzzi Whirlpool Bath Authorized Service Agent, call or write:

Jacuzzi Whirlpool Bath  
Warranty Service Department  
P.O. Box 702168  
Dallas, TX 75370-2168  
Call: 1-(866)905-2289

To obtain warranty replacement for factory-installed components for Company supplied options and accessories manufactured and supplied by the Company, call or write the above. Provide a description of the problem and proof of purchase. You will be instructed how to obtain replacements and where to return, at your expense, the failed component(s), option(s), or accessory(ies).

All replacement parts, equipment, and repairs shall assume the remaining warranty period of the part(s) replaced.

The Company's warranty obligation shall be discharged upon tender of replacement or repair. The customer's refusal to accept the tender terminates the Company's warranty obligation.

©2003 Jacuzzi Whirlpool Bath U961000F 12/04

Ninety-Day  
Parts Only  
Limited Warranty  
On  
Accessory(ies)

Ninety-Day  
Parts Only  
Limited Warranty  
On  
Accessory(ies)



### Warranty Registration Card

This card must be filled out and returned to the address printed on the other side within thirty (30) days from date of purchase in order for this warranty to be come effective.

Purchaser's Name \_\_\_\_\_

Purchaser's Address \_\_\_\_\_

City \_\_\_\_\_ State \_\_\_\_\_ Zip \_\_\_\_\_

Date of Purchase \_\_\_\_\_

Model Name \_\_\_\_\_

Serial Number \_\_\_\_\_

Dealer's Name \_\_\_\_\_

Dealer's Address \_\_\_\_\_

1. How did you first hear about this Jacuzzi® product?  
 Advertisement  Article in Magazine/Newspaper  
 Visited Dealer/Plumbing Supplier  Yellow Pages  
 Builder/Plumber/Remodeler  Decorator/Architect  
 Visited Retailer/Home Center Store  
 Word of Mouth . . . Friend/Relative/Acquaintance  
 Other (Please Describe) \_\_\_\_\_
2. Who first gave you specific information about this product (specifications, prices, etc.)?  
 Dealer/Plumbing Supplier  Builder  Remodeler  
 Plumbing Contractor  Retailer/Home Center Store  
 Decorator/Architect  Already installed
3. What was the main reason for purchase?  
 Styling  Warranty Service  Product Features  
 Brand Name  Price  Hydrotherapy  
 Home Resale  
 Other \_\_\_\_\_
4. Who finally decided which product you would buy?  
 Self  Spouse  Self and Spouse Together  
 Other Family Member  Designer/Architect  
 Builder/Plumber/Remodeler  Already installed  
 Who installed?  Already installed/New Home  
 Contractor/Plumber when remodeling  
 Self/Spouse when remodeling  
 Other \_\_\_\_\_
6. What is the current market value of this property?  
 Please estimate \$ \_\_\_\_\_ years
7. What is the age of the head of the household?  
 1 day  2 months- 6 months  
 2-7 days  6 months- 1 year  
 1 week- 2 weeks  1 year- 2 years  
 2 weeks- 4 weeks  +2 years
9. How long did you shop before purchasing unit?  
 1 day  2 months- 6 months  
 2-7 days  6 months- 1 year  
 1 week- 2 weeks  1 year- 2 years  
 2 weeks- 4 weeks  +2 years
10. Approximately how long have you lived in this home?  
 household \_\_\_\_\_  
 Up to \$24,999  \$50,000 to \$74,999  
 \$25,000 to \$29,999  \$75,000 to \$99,999  
 \$30,000 to \$39,999  \$100,000 to \$149,999  
 \$40,000 to \$49,999  \$150,000 and Above
12. Was your purchase process?  
 Very easy  Easy  Difficult  Very Difficult  
 How technically aware were you of the patented Jacuzzi® jet system prior to your purchase?  
 Not aware  Somewhat aware  Very aware

**JACUZZI WHIRLPOOL BATH**  
U961000F