

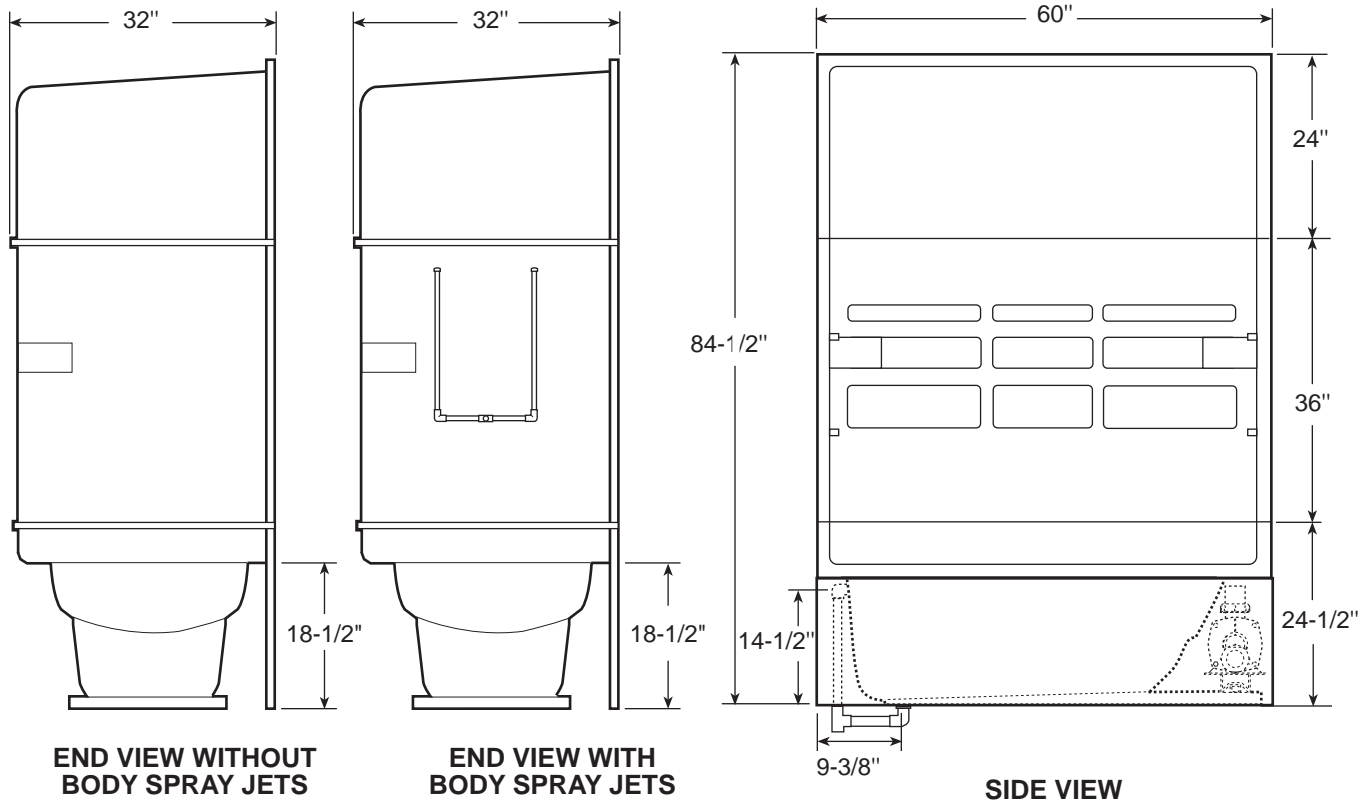

# Vantage™ Whirlpool Bath with Surround INSTALLATION INSTRUCTIONS

Each whirlpool bath arrives ready for installation, completely equipped with motor/pump assembly and plumbing and fittings necessary for whirlpool operation. An optional drain/overflow kit is available for installation on the bath.



## SPECIFICATIONS

DIMENSIONS		MOTOR/PUMP	TOTAL WEIGHT/ FLOOR LOADING	OPERATING GALLONAGE	PRODUCT WEIGHT	WATER PRESSURE	ELECTRICAL REQUIREMENTS
60"	(1524 mm) L	115 VAC	805 lb	38 U.S. gal	238 lb	40 psi min.	115 VAC
32"	(813 mm) W	3450 RPM/10 AMP	(366 kg)/	(144 liters)	(108 kg)	(2.8 Bar)	15 AMP
84-1/2"	(2146 mm) H	60 Hz Single Phase	60 lb/sq. ft. (293 kg/sq. m)				60 Hz Requires dedicated separate circuit

Use installation instructions provided with product.

Product specifications are subject to change without notice.

**Optional Features:** Trim Kit, Timer, Drain/Overflow Kit, Lamp Package, Pillow, Optica 300 Shower Mixer Valve and SteamPro™ 120 Steam Generator

## Important: Read complete instructions before beginning installation.

Remove the bath from the carton. Retain the shipping carton until satisfactory inspection of the product has been made. **Do not lift the bath by the plumbing at any time; handle by the shell only.**

Immediately upon receipt, inspect the shell before installing. Should inspection reveal any damage or defect in the finish, do not install the bath. Damage or defect to the finish claimed after the bath is installed is excluded from the warranty. Jacuzzi Whirlpool Bath's responsibility for shipping damage ceases upon delivery of the products in good order to the carrier. Refer any claims for damage to the carrier. For definitions of warranty coverage and limitations, refer to the published warranty information packed with the product.

All bath units are factory tested for proper operation and watertight connections prior to shipping. **Note: Prior to installation, the bath must be filled with water and operated to check for leaks that may have resulted from shipping damage or mishandling.** Jacuzzi Whirlpool Bath is not responsible for any defect that could have been discovered, repaired, or avoided by following this inspection and testing procedure.

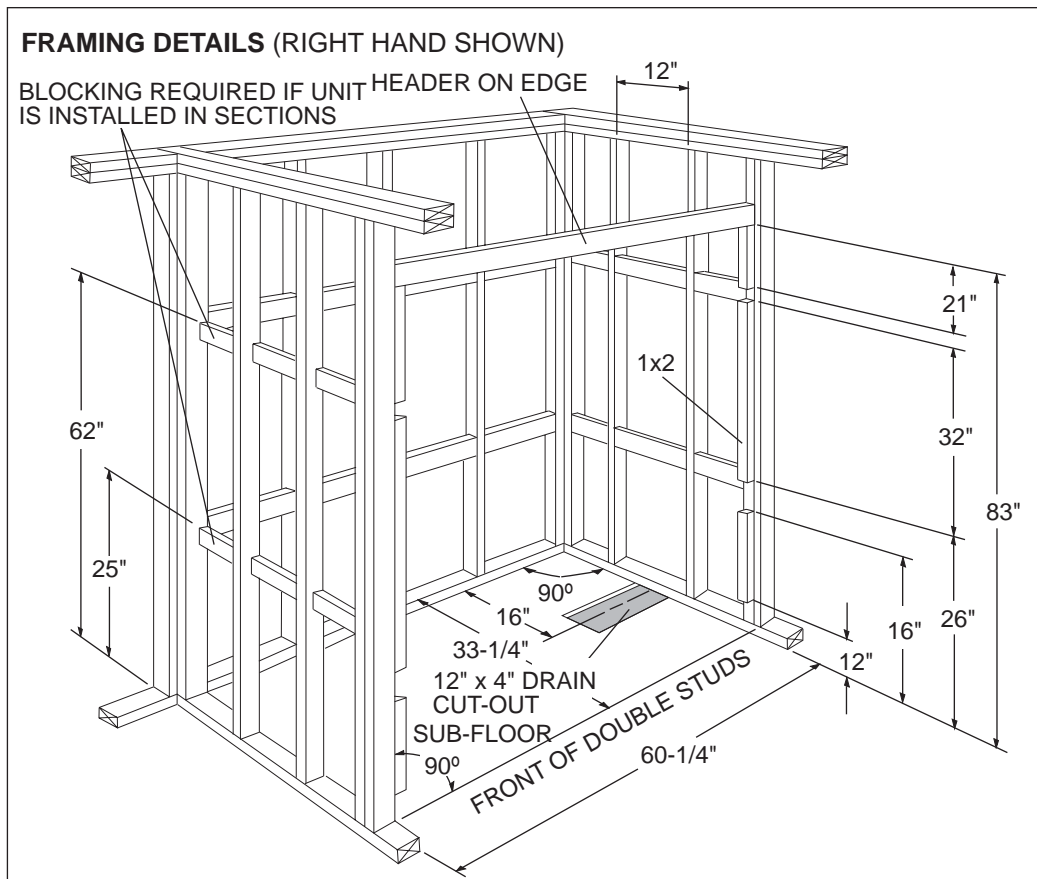

## Framing and Support

The optional drain/overflow of the bath extends below the bottom of the bath. Note that this requires a cutout in the floor.

**The floor structure beneath the bath must be able to support a total weight of approximately 805 pounds (bath, water and bather) or 60 pounds per square foot.** If the subfloor is level, no other preparation is necessary. You can proceed to install the bath. If the subfloor is not level, you **MUST** level the entire surface prior to installing the bath. The use of materials that shim or provide a level installation are allowed provided the method used will insure a level bath that is supported from the bottom. Materials that may be used are a floor leveling compound, mortar, plaster or minimal expansion structural foam having a density of a minimum of 5 lbs./cubic ft.; however the bath must remain level in order for it to drain properly and the foam feet must make full contact with the mortar, plaster or structural foam foundation. (The bath must be supported as outlined above.) Both sides of a joint or splice of subfloor should be level to each other. **When attaching baths with flanges to stud wall, use shims to fill any gaps between the bath flange and studs.**

The rim of the bath is not designed to support weight. If finish material is to overlap or contact the bath, the added weight must be fully self-supporting.

**The protective film liner inside the bath is used to prevent damage to the finish from shoes, tools, etc. during installation. Before installation, remove liner to inspect for any defects, reapply and do not remove until final cleanup.**

The bath unit should be installed after construction of the studwall and rough plumbing is in place. The bath may be installed as a single unit or, if necessary, disassembled and installed in three sections.

It is important that the framed pocket be plumb and square and that the framing members be located as detailed in the framing illustration. If the bath unit is to be installed in an existing bathroom studwall, additional studs must be added to the dimensions shown.

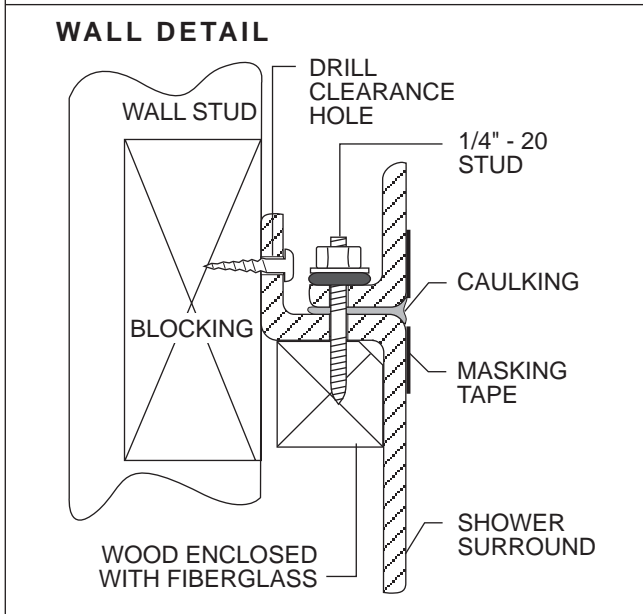
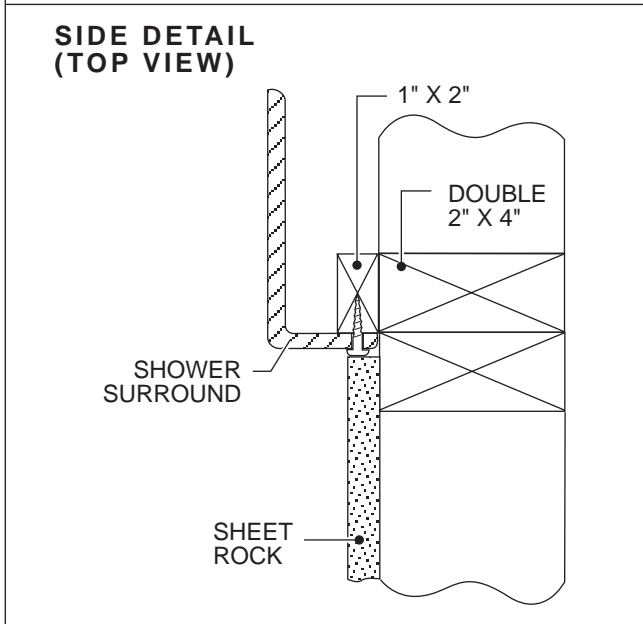
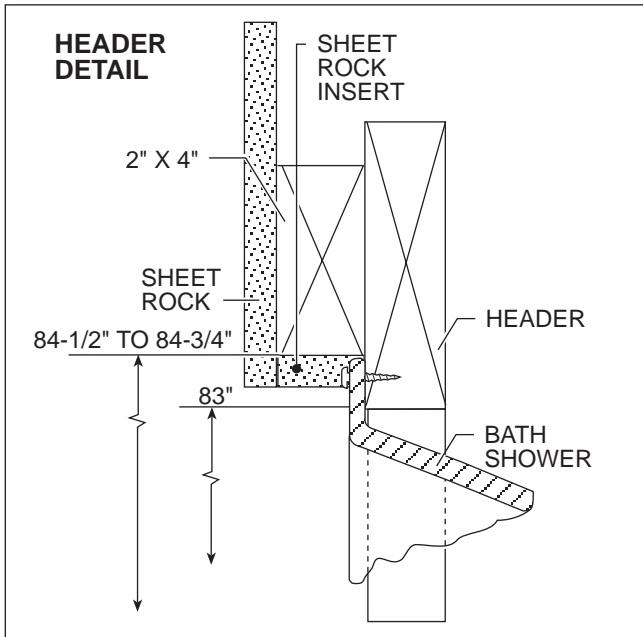

## Rough Plumbing

The locations of the valves, fill spout and shower head should be marked and drilled before the bath unit is placed in position. Where access to connections is limited, allow enough flexibility in the supply lines for easier positioning of the valves after the unit is in place.

From stable reference points such as the subfloor and front of the double studs, measure and note the locations of the fill spout, valves and shower head arm.

To avoid obstructions during installation, ensure that water lines, spout pipes and valve plumbing do not project into the studwall pocket.

## Installation

Slide the bath into the framed opening and secure the front flanged sides to the 1x2 strips and the top flange to the header. The bathtub should be level and supported along the base.

It may be necessary to disassemble the bath to install it. Install the bathtub portion making sure it is level and properly secured to the floor and studwall blocking. Apply a bead of adhesive caulking to the top of the flange surface and place the middle section over the studs of the bath flange. Push down firmly to assure that the middle section is seated and level. Secure the top flange of the middle section to the studwall blocking and the sides to the 1x2 verticals. Repeat the same caulking procedure for the top section and secure it to the header and 1x2 verticals.

If the bath with the surround is installed in one piece without being disassembled, it is necessary to caulk all joints between the bath, middle wall, and top cap. To make caulking the joints easier, place masking tape on each side of the joint as shown in the illustration. Apply a bead of caulking along the joint between the tape. Smooth out the caulking with a tool or finger. Remove tape after caulking has set.

**ROUGH-IN PLUMBING DETAILS**

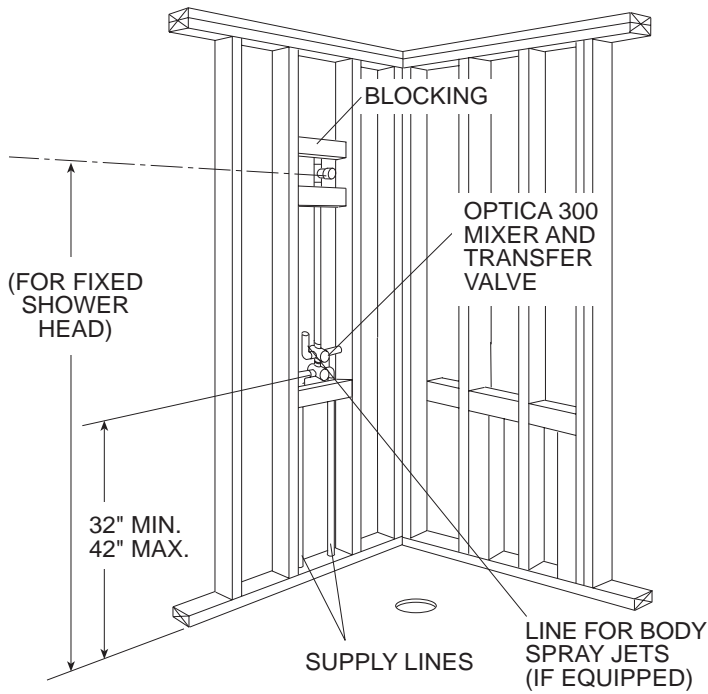

**OPTICA 300 CONNECTIONS**

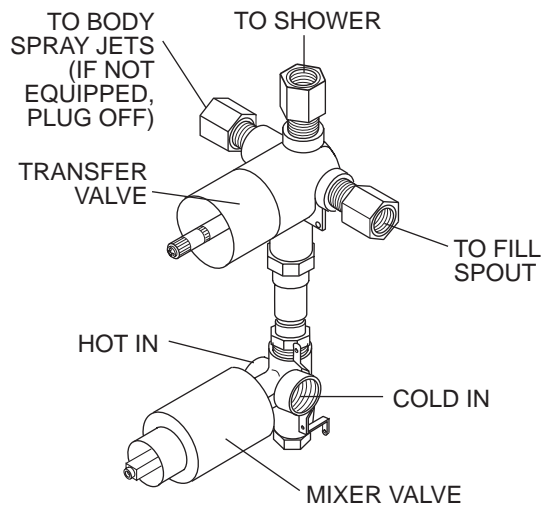

**SUGGESTED PLUMBING LAYOUT  
(REVERSE FOR RIGHT HAND VERSION)**

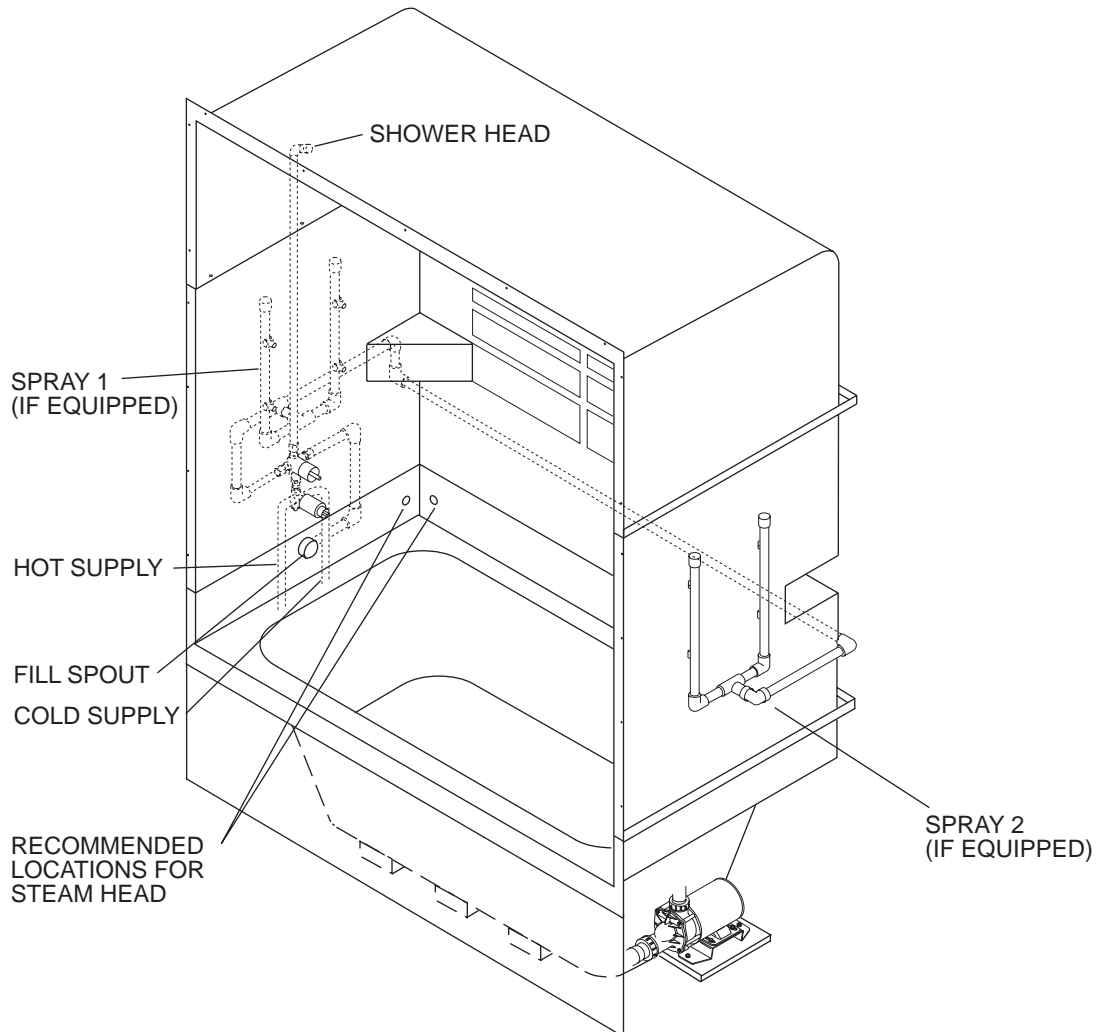

## Service Access

Service access is through the removable panel in the integral skirt. Allow a space of at least 8" away from the bath for skirt removal.

The skirt is designed to accommodate the added height of the tile, linoleum or other floor coverings up to 1-1/4" above the floor, and will be flush with the floor when installed.

When the bath is not installed with the skirt, provide adequate ventilation (minimum 30 square inch opening) for cooling of the motor and sufficient air supply for jets.

## Electrical Connections

A separate 115 VAC 15 AMP circuit, which must be protected by a Ground Fault Circuit Interrupter (GFCI), is required. Because these units are manufactured with a safe, convenient Magic Touch whirlpool ON/OFF switch on the bath itself, no remote switch or timer is necessary. Install a 115 VAC, 15 AMP duplex outlet to the studwall underneath the bathtub, at least 4" above the floor. Duplex outlet is not provided.

**DANGER: RISK OF ELECTRIC SHOCK. Connect only to a circuit protected by a Ground Fault Circuit Interrupter.**

**CAUTION: Operating the motor/pump without sufficient water in the bath can cause leaking and permanent damage to the pump. Before power is applied to the installation, make sure the switch is in the OFF position to avoid pump damage.**

If installation of an optional timer is desired, refer to wiring instructions provided with the timer. An optional timer is available from Jacuzzi Whirlpool Bath for 115 VAC operation.

## Plumbing

Pump, jets and suction fittings for the whirlpool system are factory plumbed in PVC schedule 40 piping.

All Jacuzzi Whirlpool Bath products are factory tested for proper operation and watertight connections prior to shipping. If leaks are detected, notify your Jacuzzi Whirlpool Bath Dealer, do not install the unit.

## Water Supply

Consult local authorities for plumbing code requirements in your area.

**IMPORTANT: Proper installation of the fill spout plumbing and compliance with local codes is the responsibility of the installer. Jacuzzi Whirlpool Bath does not warrant connections of water supply fittings and piping, fill systems or drain/overflow systems. Nor is it responsible for damage to the bath which occurs during any installation procedure.**

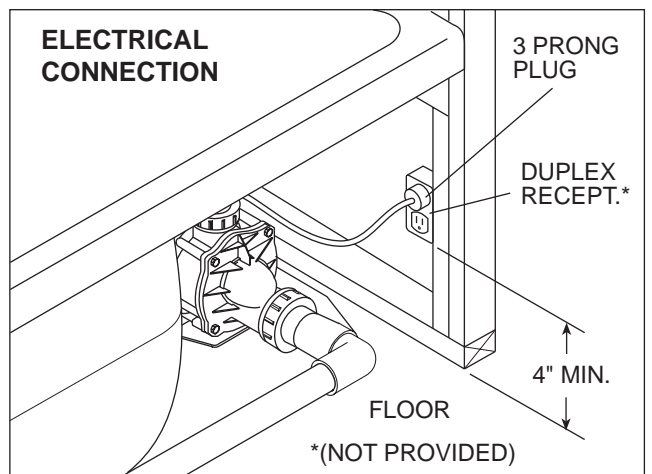
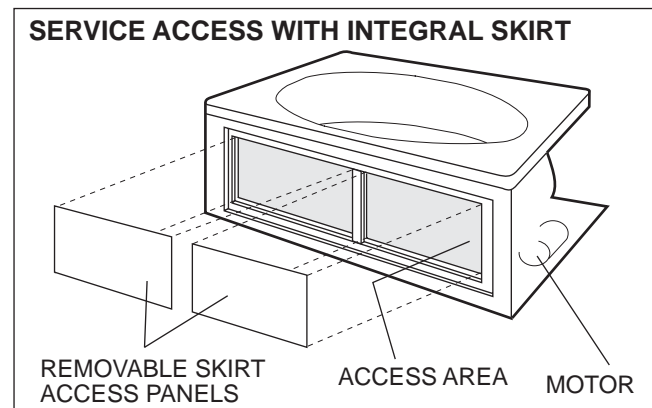
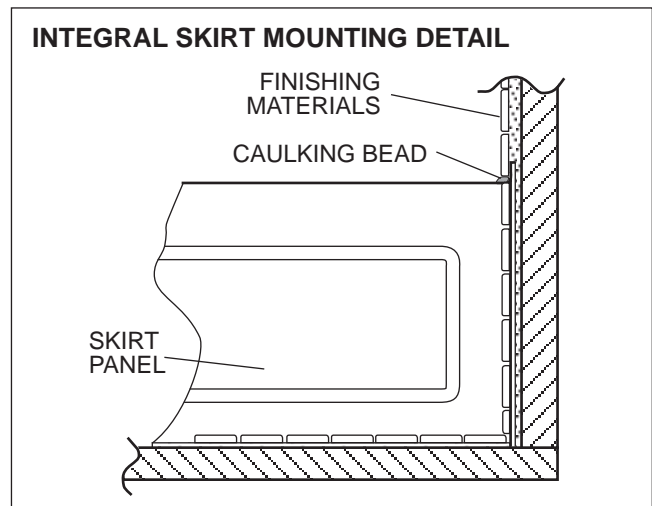

## Drain Information

A drain/overflow assembly, purchased separately from the bath, must be installed on the bath, water tested, and connected to the sanitary system of the house. After opening the carton, inspect for damage and verify that the kit is of the proper finish. If a Jacuzzi Whirlpool Bath drain/overflow is being installed, note that the waste flange, strainer, overflow cover and cover screws are packaged in a separate package within the kit to protect the trim finish. Follow the installation instructions provided with the drain/overflow kit. After the drain is fully installed, test for proper drainage. If the unit does not drain properly, rectify this condition before proceeding with the installation. Jacuzzi Whirlpool Bath is not responsible for removal and or reinstallation costs.

**NOTE: Watertight installation of the drain is the installer's responsibility. Any occurrence of drain leakage is excluded from the Jacuzzi Whirlpool Bath warranty coverage of this product.**

**CAUTION: A nonflammable protective barrier must be placed between soldering work and bath unit to avoid possible damage to the bath.**

## Clean-Up After Installation

To avoid dulling and scratching the surface of the bath, never use abrasive cleaners. A mild liquid detergent and warm water will clean soiled surfaces.

Remove spilled plaster with a wood or plastic edge. Metal tools will scratch the surface. Spots left by plaster or grout can be removed if lightly rubbed with detergent on a damp cloth or sponge.

Paint, tar, or other difficult stains can be removed with paint thinner, turpentine, or isopropyl alcohol (rubbing alcohol).

Minor scratches which do not penetrate the color finish can be removed by lightly sanding with 600-grit wet/dry sandpaper. You can restore the glossy finish to the acrylic surface of the bath with a special compound, Meguiar's #10 Mirror Glaze. If that is not available, use automotive rubbing compound followed by an application of automotive paste wax.

Major scratches and gouges which penetrate the acrylic surface will require refinishing. Ask your Jacuzzi Whirlpool Bath dealer for special instructions.

## Operation

For instructions, see owner's manual.

**PRODUCT SPECIFICATIONS ARE SUBJECT TO CHANGE WITHOUT NOTICE.  
USE INSTALLATION INSTRUCTIONS SUPPLIED WITH PRODUCT.**

Jacuzzi Whirlpool Bath has obtained applicable code (standards) listings generally available on a national basis for products of this type. It is the responsibility of the installer/owner to determine specific local code compliance prior to installation of the product. Jacuzzi Whirlpool Bath makes no representation or warranty regarding, and will not be responsible for any code compliance.

### Jacuzzi Whirlpool Bath

P.O. Box 702168, Dallas, TX 75370-2168

**Service Support:** Call (800) 288-4002

©1999 Jacuzzi Whirlpool Bath P592000 8/13/04



Printed on Recycled Paper

Printed in the U.S.A.

# Jacuzzi Whirlpool Bath Limited Warranty Builder Group Bath Product

## WARRANTY COVERAGE

Jacuzzi Whirlpool Bath (the "Company") offers the following express limited warranty to the original purchaser of any Jacuzzi Whirlpool Bath Builder Group Bath Product ("unit") who purchases the product for personal or single family use ("user"). The Company will repair or replace, at its option, the unit or its equipment in accordance with the following terms and conditions.

### ONE YEAR LIMITED WARRANTY ON BATHS

Our warranty on Builder Group Bath products is for one (1) year. Our warranty covers the unit and factory-installed components (e.g., pump, motor) against defects in material or workmanship. Warranty coverage begins on the date the unit was originally purchased by the user.

### NINETY DAY (PARTS ONLY) LIMITED WARRANTY ON OPTIONS AND ACCESSORIES

Our warranty on options and accessories manufactured by the Company is for ninety (90) days for parts only. Our warranty covers options and accessories manufactured by the Company (e.g., fill spout kits, trim kits, skirts) against defects of material or workmanship. Warranty coverage begins on the date the option or accessory was originally purchased by the user.

## WARRANTY LIMITATIONS

Our warranty does not cover defects, damage, or failure caused by the common carrier, installer, user, or other person, or resulting from, without limitation, any of the following: careless handling (lifting unit by plumbing, abrading finish, etc.) including its own negligence; modification of any type for any reason (including modification to meet local codes); improper installation (including installation not in accordance with instructions and specifications provided with the unit); connections supplied by the installer of the equipment; improper voltage supply or unauthorized electrical modification; misuse; incorrect operation, or lack of proper routine maintenance; operation of the unit without specified minimum amount of water or at inappropriate water temperature; use of abrasive or improper cleaners; or acts of God, such as lightning, floods, earthquakes, etc.

In addition, THE COMPANY WILL NOT BE RESPONSIBLE FOR INCIDENTAL OR CONSEQUENTIAL DAMAGES or losses arising from any cause (e.g., water damage to carpet, ceiling, loss of use, etc.) including its own negligence; damages to, respecting, or resulting from: plated parts when pool and/or spa chemicals are used in the unit; optional bath equipment not manufactured by the Company, supplied by Dealer, installer or the Company; the unit's prior usage as an operational display; or defects that should have been discovered before installation. This limited warranty does not include: labor, transportation, or other costs incurred in the removal and/or reinstallation of the original unit and/or installation of a replacement unit; any costs relating to obtaining access for repair; or loss of use damage, including loss of sales, profit or business advantage of any kind under any circumstances. Bath units in commercial use are excluded from any warranty coverage if any addition, deletion, or modification of any kind whatsoever has been made to the unit (or to any component).

Warranty coverage is provided in the United States of America only.

## IMPLIED WARRANTIES

All implied warranties of merchantability and fitness for a particular purpose are equal in duration with the express warranties set forth herein.

NOTICE: This warranty gives you specific legal rights, and you may also have other rights which vary from state to state. There are no warranties applicable to Jacuzzi Whirlpool Bath products except as expressly stated herein or as implied by applicable state and federal laws. The Company will not be responsible for any statements or representations made in any form that go beyond, are broader than or are inconsistent with any authorized literature or specifications furnished by the Company.

Some states do not allow limitations on how long an implied warranty lasts, or the exclusion or limitation of incidental or consequential damages, so the above limitations and exclusions may not apply to you.

## RETURN OF WARRANTY CARD

The attached Warranty Registration Card MUST be filled out by the purchaser within thirty (30) days from purchase and mailed to Jacuzzi Whirlpool Bath in order for this warranty to become effective.



Jacuzzi Whirlpool Bath  
P.O.Box 702168  
Dallas, TX 75370-2168

## RESPONSIBILITIES OF OTHERS

Inspecting the unit prior to installation is the responsibility of the installer or building contractor who acts on behalf of the user. They are responsible for ensuring the unit is free of defect or damage. Notices are placed on and in the unit and on the shipping carton advising the installer of this responsibility. In the event of a problem, the unit must not be installed. The Company is not responsible for failures or damage that could have been discovered, repaired, or avoided by proper inspection and testing prior to installation.

Damage occurring in transit is the responsibility of the carrier. The user or installer MUST open the crate and inspect the unit for damage when it is delivered. If damage is discovered, it must be reported immediately to the seller and the carrier in writing, and an inspection requested. Failure of the carrier to respond should be reported to the seller and the carrier. Your freight claims should be filed promptly thereafter.

It is the responsibility of the installer, building contractor, or user to provide access for service. The Company is not responsible for any costs relating to obtaining access for repair. The user shall bear such costs and, if appropriate, must seek recovery from the installer.

Damage occurring to the unit during installation is the responsibility of the installer and/or building contractor and damage occurring thereafter is the responsibility of the user.

Failure of any optional equipment is the sole responsibility of the equipment manufacturer. (Options and accessories manufactured by the Company are warranted for ninety (90) days from the original date of purchase for parts only.)

The Distributor or Dealer is responsible for knowing local code requirements and notifying the installing contractor and/or user of these requirements at the time of purchase. The Company is not responsible for costs to modify any product to obtain any code approval, such as city, county, or state building codes.

## WARRANTY SERVICE

For the customer's benefit, the Company maintains a list of independent service personnel to perform required warranty service repairs. Such firms are not agents or representatives of the Company and cannot bind the Company by words or conduct.

The Company will provide the warranty service described above when the following conditions have been met: the failure is of the nature or type covered by the warranty; the user has informed an Authorized Jacuzzi Whirlpool Bath Service Agent or Warranty Service Department Representative of the nature of the problem during the warranty period; conclusive evidence (e.g., proof of purchase or installation) is provided to the foregoing by the user proving that the failure occurred or was discovered within the warranty period; an authorized independent service person or Company representative has been permitted to inspect the unit during regular business hours within a reasonable time after the problem was reported by the user.

In order to obtain warranty service, consult your local telephone book for the location of the nearest Jacuzzi Whirlpool Bath Authorized Service Agent. Describe the problem and the Authorized Service Agent will inspect the unit and provide the required warranty service.

If you are unable to contact a Jacuzzi Whirlpool Bath Authorized Service Agent, call or write:

Jacuzzi Whirlpool Bath  
Warranty Service Department  
P.O. Box 702168  
Dallas, TX 75370-2168  
Call: 1-(800) 288-4002

To obtain warranty replacement for factory-installed components for Company supplied options and accessories manufactured and supplied by the Company, call or write the above. Provide a description of the problem and proof of purchase. You will be instructed how to obtain replacements and where to return, at your expense, the failed component(s), option(s), or accessory(ies).

All replacement parts, equipment, and repairs shall assume the remaining warranty period of the part(s) replaced.

The Company's warranty obligation shall be discharged upon tender of replacement or repair. The customer's refusal to accept the tender terminates the Company's warranty obligation.

©1999 Jacuzzi Whirlpool Bath P592000 8/13/04

Ninety-Day  
Parts Only  
Limited Warranty  
On  
Accessory(ies)

Ninety-Day  
Parts Only  
Limited Warranty  
On  
Accessory(ies)



### Warranty Registration Card

This card must be filled out and returned to the address printed on the other side within thirty (30) days from date of purchase in order for this warranty to be come effective.

Purchaser's Name \_\_\_\_\_  
Purchaser's Address \_\_\_\_\_  
City \_\_\_\_\_ State \_\_\_\_\_ Zip \_\_\_\_\_

Date of Purchase \_\_\_\_\_  
Model Name \_\_\_\_\_  
Serial Number \_\_\_\_\_  
Dealer's Name \_\_\_\_\_  
Dealer's Address \_\_\_\_\_

1. How did you first hear about this Jacuzzi® product?  
 Advertisement  Article in Magazine/Newspaper  
 Visited Dealer/Plumbing Supplier  Yellow Pages  
 Builder/Plumber/Remodeler  Decorator/Architect  
 Visited Retailer/Home Center Store  
 Word of Mouth . . . Friend/Relative/acquaintance  
 Other (Please Describe) \_\_\_\_\_

2. Who first gave you specific information about this product (specifications, prices, etc.)?  
 Dealer/Plumbing Supplier  Builder  Remodeler  
 Plumbing Contractor  Retailer/Home Center Store  
 Decorator/Architect  Already installed  
 Styling  Warranty Service  Product Features  
 Brand Name  Price  Hydrotherapy  
 Home Resale \_\_\_\_\_  
 Other \_\_\_\_\_

4. Who finally decided which product you would buy?  
 Self  Spouse  Self and Spouse Together  
 Other Family Member  Designer/Architect  
 Builder/Plumber/Remodeler  Already installed  
 Contractor/Plumber when remodeling  
 Self/Spouse when remodeling  
 Other \_\_\_\_\_

6. What is the current market value of this property?  
Please estimate \$ \_\_\_\_\_

7. What is the age of the head of the household? \_\_\_\_\_ years

8. What other manufacturers did you consider?  
 Eljer  Lasco  Price Pfister  Aqua Glass  
 Kohler  American Standard  Sterling  
 Other (Specify) \_\_\_\_\_

9. How long did you shop before purchasing unit?  
 1 day  2 months-6 months  
 2-7 days  6 months-1 year  
 1 week-2 weeks  1 year-2 years  
 2 weeks-4 weeks  +2 years

10. Approximately how long have you lived in this home?  
Please indicate, approximately, the total annual income of your household.  
 Up to \$24,999  \$50,000 to \$74,999  
 \$25,000 to \$29,999  \$75,000 to \$99,999  
 \$30,000 to \$39,999  \$100,000 to \$149,999  
 \$40,000 to \$49,999  \$150,000 and Above

12. Was your purchase process?  
 Very easy  Easy  Difficult  Very Difficult

13. How technically aware were you of the patented Jacuzzi® jet system prior to your purchase?  
 Not aware  Somewhat aware  Very aware

JACUZZI WHIRLPOOL BATH  
P592000  
8/13/04