



N4300



Figure not included and sold separately.

Please keep this instruction sheet for future reference, as it contains important information.

Requires three "AA" (LR6) alkaline batteries (not included).

Adult assembly is required.

Tool required for battery replacement: Phillips screwdriver (not included).



theplanetheroes.com

BATTERY INSTALLATION

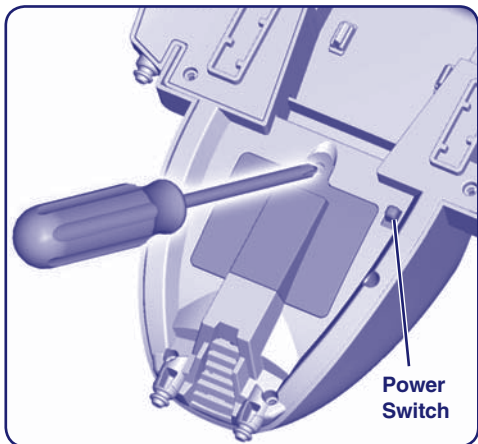

- Locate the battery compartment on the bottom of the toy.
 - Loosen the screw in the battery compartment door with a Phillips screwdriver. Remove the battery compartment door.
 - Insert three “AA” (LR6) **alkaline** batteries.
- Note:** We recommend using **alkaline** batteries for longer battery life.
- If this toy begins to operate erratically, you may need to reset the electronics. Slide the power switch off and then back on.
 - When sounds from this toy become faint or stop, it’s time for an adult to change the batteries.
-  • Protect the environment by not disposing of this product with household waste (2002/96/EC). Check your local authority for recycling advice and facilities.

BATTERY SAFETY INFORMATION

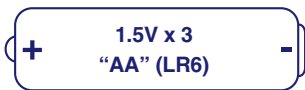

In exceptional circumstances, batteries may leak fluids that can cause a chemical burn injury or ruin your toy. To avoid battery leakage:

- Do not mix old and new batteries or batteries of different types: alkaline, standard (carbon-zinc) or rechargeable (nickel-cadmium).
- Insert batteries as indicated inside the battery compartment.
- Remove batteries during long periods of non-use. Always remove exhausted batteries from the toy. Dispose of batteries safely. Do not dispose of the product in a fire. The batteries inside may explode or leak.
- Never short-circuit the battery terminals.
- Use only batteries of the same or equivalent type, as recommended.
- Do not charge non-rechargeable batteries.
- Remove rechargeable batteries from the toy before charging.
- If removable, rechargeable batteries are used, they are only to be charged under adult supervision.



CONSUMER ASSISTANCE

Call toll free: 1-800-432-5437 (US & Canada only)
M-F 9AM to 7PM / SAT 11AM to 5PM (EST)

 service.fisher-price.com

Write to us at: Fisher-Price® Consumer Relations,
636 Girard Avenue, East Aurora, New York 14052.

Hearing-impaired consumers using TTY/TDD equipment,
please call 1-800-382-7470.

For countries outside the United States:

Canada: Mattel Canada Inc., 6155 Freemont Blvd.,
Mississauga, Ontario L5R 3W2; www.service.mattel.com.

Great Britain: Mattel UK Ltd, Vanwall Business Park,
Maidenhead SL6 4UB, Helpline: 01628 500303,
www.service.mattel.com/uk

Australia: Mattel Australia Pty. Ltd., 658 Church Street,
Locked Bag #870, Richmond, Victoria 3121 Australia.
Consumer Advisory Service 1300 135 312.

New Zealand: 16-18 William Pickering Drive,
Albany 1331, Auckland.

Asia: Mattel East Asia Ltd, Room 1106, South Tower,
World Finance Centre, Harbour City, Tsimshatsui, HK, China.

Fisher-Price, Inc., a subsidiary of Mattel, Inc.,
East Aurora, NY 14052 U.S.A.

©2008 Mattel, Inc. All Rights Reserved.

® and ™ designate U.S. trademarks of Mattel, Inc.

ASSEMBLY

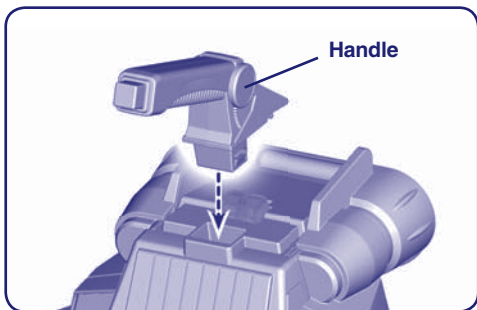

- “Snap” the handle into the top of the jet, as shown.

Note: The handle only fits one way. If it does not seem to fit, turn it around and try again!

COOL VOICES & SOUND EFFECTS



- Slide the power switch on the bottom of the toy to on ● or off ○.
- Press the buttons on of the side of the jet to hear your mission along with cool engine and laser sounds and favorite Planet Heroes® phrases!

TAKE OFF & LAND

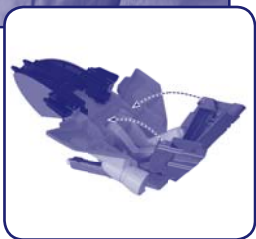

- Press the button on the end of the handle to release the landing gear for a safe landing.
- Fold the landing gear, as shown, for take off.

FCC STATEMENT

(United States Only)

This equipment has been tested and found to comply with the limits for a Class B digital device, pursuant to Part 15 of the FCC Rules. These limits are designed to provide reasonable protection against harmful interference in a residential installation. This equipment generates, uses and can radiate radio frequency energy and, if not installed and used in accordance with the instructions, may cause harmful interference to radio communications. However, there is no guarantee that interference will not occur in a particular installation. If this equipment does cause harmful interference to radio or television reception, which can be determined by turning the equipment off and on, the user is encouraged to try to correct the interference by one or more of the following measures:

- Reorient or relocate the receiving antenna.
- Increase the separation between the equipment and receiver.
- Consult the dealer or an experienced radio/TV technician for help.

Note: Changes or modifications not expressly approved by the manufacturer responsible for compliance could void the user's authority to operate the equipment.

This device complies with Part 15 of the FCC Rules. Operation is subject to the following two conditions: (1) this device may not cause harmful interference and (2) this device must accept any interference received, including interference that may cause undesired operation.

ICES-003

This Class B digital apparatus complies with Canadian ICES-003.

Operation is subject to the following two conditions: (1) this device may not cause harmful interference and (2) this device must accept any interference received, including interference that may cause undesired operation.

NMB-003

Cet appareil numérique de la classe B est conforme à la norme NMB-003 du Canada.

L'utilisation de ce dispositif est autorisée seulement aux conditions suivantes: (1) il ne doit pas produire de brouillage et (2) l'utilisateur du dispositif doit être prêt à accepter tout brouillage radioélectrique reçu, même si ce brouillage est susceptible de compromettre le fonctionnement du dispositif.

CARE

Wipe with a clean cloth dampened with a mild soap and water solution. Do not immerse.