

Fisher-Price®

www.fisher-price.com

L5895



GeoTrax
Rail & Road System

Parts

- A. Span
- B. Arch
- C. 4 Cable Structures
- D. 4 Supports
- E. Sports Car

Part not shown: 1 Figure

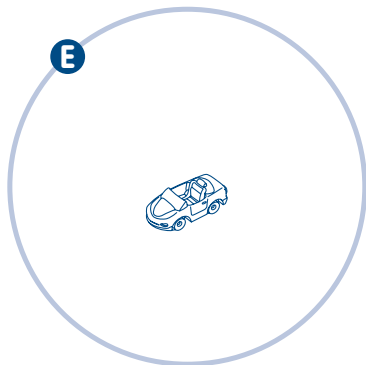
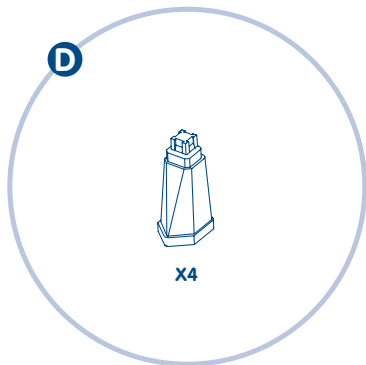
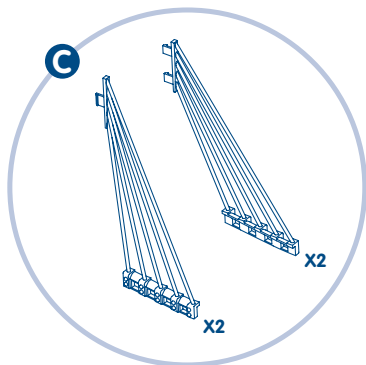
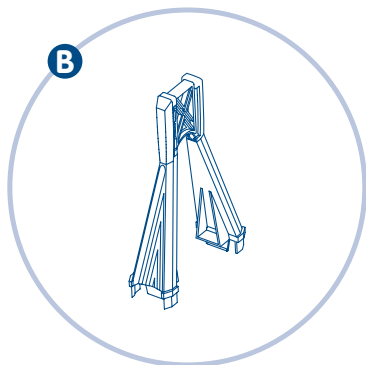
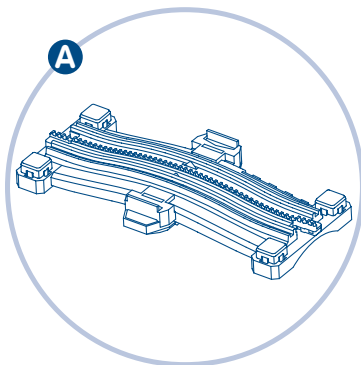

Battery Installation

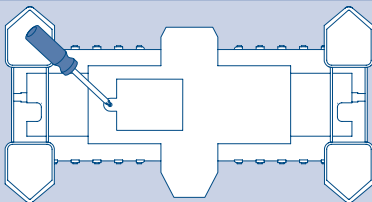

- Locate the battery compartment on the bottom of the span.
- Loosen the screw in the battery compartment door with a Phillips screwdriver. Remove the battery compartment door.
- Insert three "AAA" (LR03) **alkaline** batteries.

We recommend the use of alkaline batteries for longer battery life.

- Replace the battery compartment door and tighten the screw with a Phillips screwdriver. Do not over-tighten.
- When lights become faint or stop, it's time for an adult to change the batteries.
- Protect the environment by not disposing of this product with household waste (2002/96/EC). Check your local authority for recycling advice and facilities (Europe only).



Battery Safety Information



In exceptional circumstances, batteries may leak fluids that can cause a chemical burn injury or ruin your toy. To avoid battery leakage:

- Do not mix old and new batteries or batteries of different types: alkaline, standard (carbon-zinc) or rechargeable (nickel-cadmium).
- Insert batteries as indicated inside the battery compartment.
- Remove batteries during long periods of non-use. Always remove exhausted batteries from the toy. Dispose of batteries safely. Do not dispose of the product in a fire. The batteries inside may explode or leak.
- Never short-circuit the battery terminals.
- Use only batteries of the same or equivalent type, as recommended.
- Do not charge non-rechargeable batteries.
- Remove rechargeable batteries from the toy before charging.
- If removable, rechargeable batteries are used, they are only to be charged under adult supervision.

Assembly

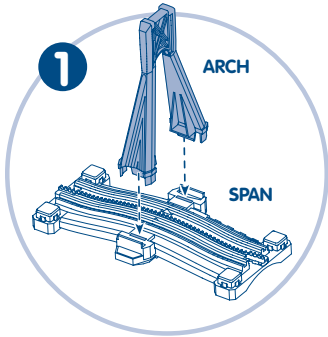

"Snap" the arch onto the span.

"Snap" a cable structure to the side of the span.

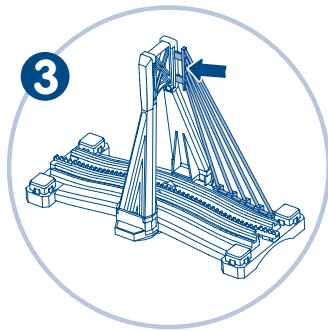
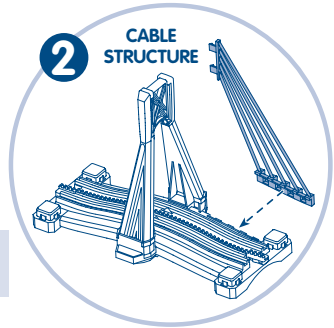

- "Snap" the top of the cable structure to the top of the arch.
- Repeat this procedure to attach the other three cable structures to the span.

Note: Each cable structure assembles to the span one way!

"Snap" the supports to the underside of the span.

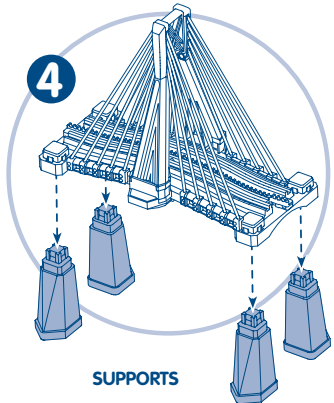

Drive Through for a Rainbow of Lights!



- Locate the power switch on the bottom of the bridge. Slide the switch to ● to turn the toy on.
- Push the car over the bridge or drive a train engine (sold separately) over to see colorful lights. You can also press the button on the bridge to see the lights.

- Remove the supports to use the bridge at ground level.
- When you are finished playing with this toy, slide the power switch off ○.

FCC Statement

United States Only

This equipment has been tested and found to comply with the limits for a Class B digital device, pursuant to Part 15 of the FCC Rules. These limits are designed to provide reasonable protection against harmful interference in a residential installation. This equipment generates, uses and can radiate radio frequency energy and, if not installed and used in accordance with the instructions, may cause harmful interference to radio communications. However, there is no guarantee that interference will not occur in a particular installation. If this equipment does cause harmful interference to radio or television reception, which can be determined by turning the equipment off and on, the user is encouraged to try to correct the interference by one or more of the following measures:

- Reorient or relocate the receiving antenna.
- Increase the separation between the equipment and receiver.
- Consult the dealer or an experienced radio/TV technician for help.

Note: Changes or modifications not expressly approved by the manufacturer responsible for compliance could void the user's authority to operate the equipment.

Fisher-Price®



Visit www.fisher-price.com to see
the entire world of GeoTrax® accessories!

Please keep this instruction sheet for future reference,
as it contains important information.

Requires three "AAA" (LR03) **alkaline** batteries (not included).

Adult assembly is required.

Tool required for battery installation: Phillips screwdriver (not included).

Wipe the toy with a clean, damp cloth. Do not immerse.



CONSUMER ASSISTANCE

Call toll free: 1-800-432-5437 (US & Canada only)
M-F 9AM to 7PM / SAT 11AM to 5PM (EST)

service.fisher-price.com

Write to us at: Fisher-Price® Consumer Relations,
636 Girard Avenue, East Aurora, New York 14052.

Hearing-impaired consumers using TTY/TDD equipment,
please call 1-800-382-7470.

For countries outside the United States:

Canada: Mattel Canada Inc., 6155 Freemont Blvd.,
Mississauga, Ontario L5R 3W2; www.service.mattel.com.

Great Britain: [Mattel UK Ltd, Vanwall Business Park,
Maidenhead SL6 4UB, Helpline: 01628 500303,
\[www.service.mattel.com/uk\]\(http://www.service.mattel.com/uk\)](http://www.service.mattel.com/uk)

Australia: Mattel Australia Pty. Ltd., 658 Church Street,
Locked Bag #870, Richmond, Victoria 3121 Australia.
Consumer Advisory Service 1300 135 312.

New Zealand: 16-18 William Pickering Drive,
Albany 1331, Auckland.

Asia: Mattel East Asia Ltd, Room 1106, South Tower,
World Finance Centre, Harbour City, Tsimshatsui, HK, China.