



## **Model APS-55** Installation Manual

### **3 Channel Remote Start / Keyless Entry System Installation Instructions**

This Unit Is Intended For Installation In Vehicles With  
12 Volt Negative Ground Electrical Systems,  
Gasoline or Diesel With True Tach Reference  
And Automatic Transmissions Only.

#### **Kit Contents**

- (1) - APS-55 Control Module
- (2) - 2 Button High Frequency Transmitters
- (1) - 3 Channel Code Learning Receiver
- (1) - Multi Pin Input/Output Harness
- (1) - Six Pin Power Harness
- (1) - Two Pin I/O Harness Factory Alarm By-Pass & Diesel Wait To Start Input
- (1) - 2 Pin Door Lock Harness
- (2) - 30 Amp In-line Fuse Holders With Fuses
- (1) - Control Switch
- (1) - Programming Switch
- (1) - Ring Terminal
- (4) - 1/2" Long Screws
- (1) - Pin Switch
- (1) - Remote Start Warning Label
- (1) - Literature Package

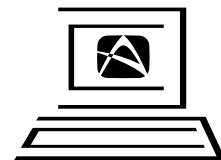

For Customer Service  
Visit Our Website At  
**[www.audiovox.com](http://www.audiovox.com)**  
Product Information, Photos,  
FAQ's, Owner's Manuals

The APS-55 Remote Start/Keyless Entry System is designed to be used with Automatic Transmission Vehicles Only! The unit provides wait to start input for glow plug pre-heat which will be used for all diesel applications. If this wire is not connected, then the unit will remain in the Gasoline mode setting which will crank the car when the RF signal is received with no delay. Regardless of the vehicle, Gasoline or Diesel, for every installation, the vehicle **MUST HAVE a Tach Signal Input, and an Automatic Transmission.**

#### **INSTALLATION OF THE MAJOR COMPONENTS:**

##### **CONTROL MODULE:**

Select a mounting location inside the passenger compartment (up behind the dashboard). The mounting location selected must be within 24" of the ignition switch wiring harness to allow connection of the 6 pin main wiring harness. Be certain that the chosen location will not interfere with proper operation of the vehicle. Avoid mounting the module to or routing the wiring around the steering shaft/column, as the module or wiring may wrap around or block the steering wheel preventing proper control of the vehicle. Secure the module in the chosen location using cable ties or screws as necessary.

Do Not Mount The Module In The Engine Compartment, as it is not waterproof.

##### **HOOD PIN SWITCH:**

The pin switch included in this package is required for the safety shut down of the remote start unit. If the vehicle is being worked on, this hood switch prevents the remote start activation even if the RF command to start is issued. This switch **MUST** be installed in all applications. Failure to do so may result in personal injury or property damage. Mount the switch in an area under the hood that is away from water drain paths. If necessary, the included brackets may be used to move the switch away from rain gutters or allow mounting to the firewall behind the hood seal. In either case the switch must be set up to allow the hood to depress the switch at least 1/4 inch when the hood is closed and fully extended when the hood is opened. For direct mounting, a 1/4 inch hole must be drilled. Carefully check behind the chosen location to insure the drill will not penetrate any existing factory wiring or fluid lines. Drill a 1/4" hole in the desired location and thread the pin switch into it using a 7/16" nut driver or deep well socket. If using the mounting bracket, first secure the bracket to the desired location and secure the pin switch in the pre-threaded mounting bracket hole.

##### **PROGRAM SWITCH :**

Select a mounting location that is within reach of the ignition switch, as this switch, in combination with the ignition switch, will be used to program the selectable features of the system. It is suggested that the switch be mounted to the lower dash panel in the driver's area. Inspect behind the chosen location to insure that adequate clearance is allowed for the body of the switch, and also that the drill will not penetrate any existing factory wiring or fluid lines. Drill a 1/4" hole in the desired location and mount the switch by passing it through the panel from the underside. Secure the switch using the nut, star washer, and on/off face plate. It is best to orientate the switch to allow the on position to be up toward the driver and the off position to be down or away from the driver. Route the switch wires toward the control module.

##### **CONTROL SWITCH:**

Select a mounting location known and accessible to the operator of the vehicle. A lower dash panel, kick panel, or glove box is desirable. Inspect behind the chosen location to insure that adequate clearance is allowed for the body of the switch, and also that the drill will not penetrate any existing factory wiring or fluid lines.

Drill a 1/4" hole in the desired location and mount the switch by passing it through the panel from the underside. Secure the switch using the nut, star washer, and on/off face plate. It is suggested that the switch be orientated to allow the on position to be up toward the driver and the off position to be down or away from the driver. Route the switch wires toward the control module. Place the RED rubber boot, included in the kit, over the switch handle to differentiate this switch from the program switch.

The APS-55 is to be used in vehicles with **AUTOMATIC TRANSMISSIONS** only! Although this combination Keyless Entry/Remote Start unit is a sophisticated system with many advanced features, **IT MUST NOT** be installed into a vehicle with a manually operated transmission. Doing so may result in serious personal injury and property damage.

**IMPORTANT!**

DO NOT PLUG THE SIX PIN MAIN POWER HARNESS OR THE MULTI PIN INPUT / OUTPUT HARNESS INTO THE CONTROL MODULE UNTIL ALL CONNECTIONS TO THE VEHICLE HAVE BEEN MADE. AFTER SELECTING YOUR TARGET WIRES AS DEFINED BELOW, DISCONNECT THE NEGATIVE BATTERY CABLE FROM THE VEHICLE BATTERY PRIOR TO MAKING ANY CONNECTIONS.

**WIRING THE 6 PIN MAIN POWER HARNESS:**

**RED w/ WHITE Trace Wire:** + 12 volt Battery 1 Source

Connect this wire to a + 12 VDC constant source found at the vehicle's ignition switch using the 30 Amp fuse and holder provided. This wire provides power for the control circuit as well as the ignition 1 and ignition 2 relays.

**RED Wire:** + 12 Volt Battery 2 Source

Connect this wire to a + 12 VDC constant source found at the vehicle's ignition switch using the 30 Amp fuse and holder provided, but NOT the same vehicle wire as used by the battery 1 source. Most vehicles have more than one battery source supplying power to the ignition switch. Separate feed wires must be used for the Red and Red/White wires. If your vehicle does not have two battery feed wires at the ignition switch then it is possible to connect both wires to the vehicle's battery. This wire provides power for the start relay and the accessory relay.

**IMPORTANT!**

It is the responsibility of the installing technician to determine the load factor of the vehicles electrical circuits when the vehicle is running and to adequately fuse the two power wires based on that load. If the vehicle, running under load with the air conditioner, heater blower motor, and accessories exceeds 24 Amps continuous, we recommend that two fuses be used in combination on each power wire as shown below. For additional information see Tech Update issued 9/30/96.

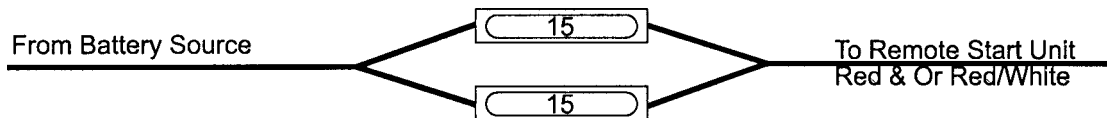

**YELLOW Wire:** Starter Output

**Careful consideration for the connection of this wire must be made to prevent the vehicle from starting while in gear. Understanding the difference between a mechanical and an electrical Neutral Start Switch will allow you to properly identify the circuit and select the correct installation method. In addition you will realize why the connection of the safety wire is required for all mechanical switch configurations.**

Failure to make this connection properly can result in personal injury and property damage. In all installations it is the responsibility of the installing technician to test the remote start unit and assure that the vehicle cannot start via RF control in any gear selection other than park or neutral.

In both mechanical and electrical neutral start switch configurations, the connection of the Yellow wire will be made to the low current start solenoid wire of the ignition switch harness. This wire will have +12 volts when the ignition switch is turned to the start (crank) position only. This wire will have 0 volts in all other ignition switch positions.

**NOTE:** This wire must be connected to the vehicle side of the starter cut relay (when used). For the electrical neutral switch configuration, this connection must be made between the starter inhibit relay, (when used) and the neutral safety switch as shown in the following diagram.

Failure to connect this wire to the ignition switch side of the of the neutral safety switch can result in personal injury and property damage.

SEE NEUTRAL START SAFETY TEST FOR FURTHER DETAILS.

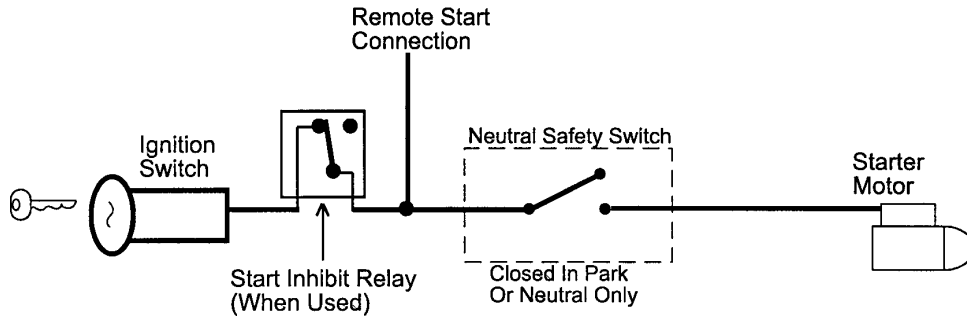

**BLUE Wire:** Ignition 1 Output

Connect this wire to the ignition 1 wire from the ignition switch. This wire will show +12 volts when the ignition key is turned to the "ON" or "RUN" and the "START" or "CRANK" positions and will have 0 volts when the key is turned to the "OFF" and "ACCESSORY" positions.

For Diesel Applications, this wire must be connected to the ignition circuit that powers the glow plugs if the vehicle requires glow plug pre-heating.

**GREEN Wire:** Ignition 2 Output

Connect this wire to the ignition 2 wire from the ignition switch. This wire will show + 12 volts when the ignition key is turned to the "ON" or "RUN" position and in some cases the "START" or "CRANK" position. This wire will show 0 volts when the key is turned to the "OFF" and "ACCESSORY" positions.

**NOTE:** See programming information concerning this wire to allow output during the "START" mode.

**VIOLET Wire:** Accessory Output

Connect this wire to the Accessory wire from the ignition switch. This wire will show + 12 volts when the ignition switch is turned to the "ACCESSORY" or "ON" and "RUN" positions and will show 0 volts when the key is turned to the "OFF" and "START" or "CRANK" positions.

WIRING THE 6 PIN MAIN POWER HARNESS

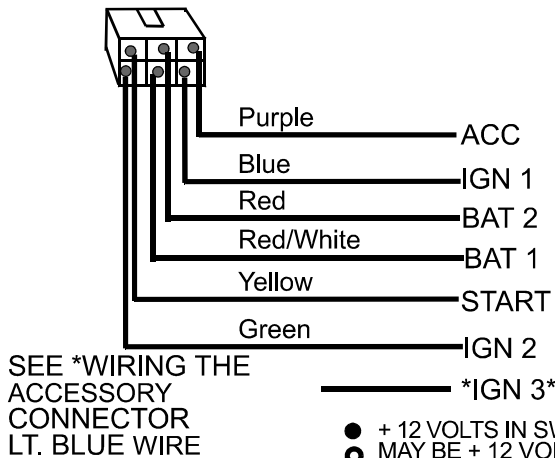

IGNITION SWITCH KEY POSITIONS

	OFF	ACCESSORY	ON/RUN	START
Purple (ACC)		●	●	
Blue (IGN 1)			●	●
Red (BAT 2)	●	●	●	●
Red/White (BAT 1)	●	●	●	●
Yellow (START)				●
Green (IGN 2)			●	○
*IGN 3*			●	○

- + 12 VOLTS IN SWITCH POSITION INDICATED
- MAY BE + 12 VOLTS IN SWITCH POSITION INDICATED
- \* THIS CIRCUIT IS NOT ALWAYS REQUIRED FOR INSTALLATION

## WIRING CONNECTIONS: 12 Pin Input / Output Harness

### **Black Wire:** Chassis Ground Source

Connect the Black wire to a known vehicle ground source or to a solid clean metal part of the chassis. Be certain to remove any paint or grease and secure this wire with a self tapping screw and ring terminal.

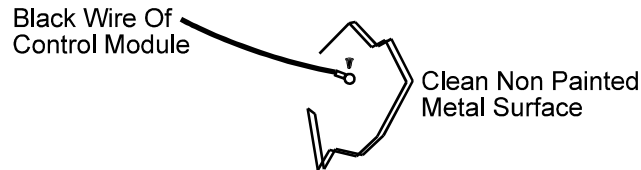

### **BLACK w/WHITE Tracer Wire: Control Switch**

The Black w/ White tracer wire provides ON-OFF control of the Remote Starter.

When the Black w/ White wire is switched to a full time ground, the APS-55 Remote Start Module is operative. When the Black w/ White wire is at open circuit through the control switch, the remote starter is disabled.

Connect the Black w/ White tracer wire to one of the wires from the back of the previously mounted control switch. Connect the remaining wire of the control switch to chassis ground. Always try to mount the switch so that the ON position is in an upward or toward the driver direction.

### **GREY Wire: Negative Inhibit Input 1**

Connect the GREY wire to the previously mounted hood pin switch provided. This wire will be routed through the fire wall into the engine compartment. It is necessary to use an existing grommet when passing wires through the fire wall to prevent short circuiting. This is an important safety feature of APS-55, and failure to use this feature can result in serious injury. Route the wire to the pin switch and connect it using the bullet connector provided.

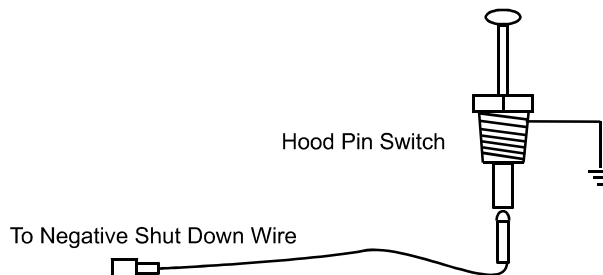

### **GREY w/ BLACK Tracer Wire: Negative Inhibit Input 2**

Any time the grey w/ black tracer wire is grounded, the Remote Starter will stop operating, even if the signal is received from the transmitter.

If the brake light switch in the vehicle switches ground to the brake light circuit, connect the Grey w/ Black trace wire to the output of the brake light switch. If the brake light switch in the vehicle switches +12 Volts, do not use the Grey w/ Black wire; see Brown w/ Black tracer wire.

### **BROWN Wire: Positive Inhibit Input 1**

Any time + 12 Volts is applied to the Brown wire, the Remote Starter will stop operating, even if the signal is received from the transmitter.

If the vehicle has a factory installed hood pin switch and that switch provides + 12 Volts to an under hood light, the Brown wire can be connected to the existing pin switch.

### **BROWN w/ BLACK Tracer Wire: Positive Inhibit Input 2**

Any time + 12 Volts is applied to the Brown w/ Black tracer wire, the Remote Starter will stop operating, even if the signal is received from the transmitter. If the brake light switch in the vehicle switches + 12 Volts to the brake light circuit, connect

the Brown w/ Black trace wire to the output of the brake light switch. If the brake light switch in the vehicle switches ground, do not use the Brown w/ Black wire; see Grey w/ Black tracer wire.

### **Brake Switch Positive Shutdown Detail**

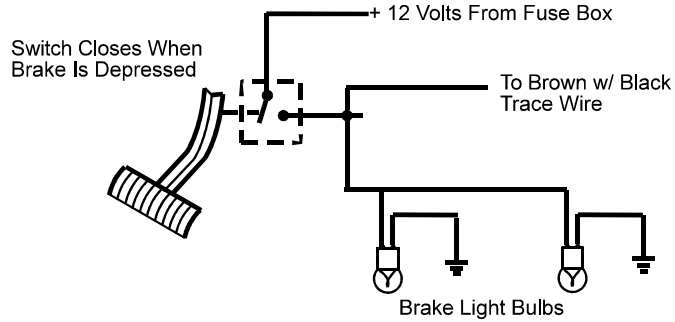

### **YELLOW w/ BLACK Tracer Wire: + 12 Volt Alarm By - Pass Output**

**NOTE: YOU MUST DISCONNECT THE IGNITION INPUT OF THE ALARM FROM ANY OTHER WIRE THAT IT IS PRESENTLY CONNECTED TO IN THE VEHICLE.**

This wire provides a + 12 Volt output when the ignition key is turned to the "ON" position, and 0 Volts when the ignition key is "OFF" and when the vehicle is running under the control of the remote starter.

This wire should be connected to the ignition input of the alarm system.

The Yellow w/ Black wire output will allow you to remote start the vehicle while leaving the alarm armed, and to lock/unlock the doors while running under control of the remote start unit.

### **(2) WHITE Wires: Parking Light Flasher**

These wires are the COMMON and NORMALLY OPEN contacts of the on-board parking lamp relay.

If the vehicle's parking lights are a +12 volt switched system, connect (1) of the White wires to a fused (15A max.) +12 volt battery source, and connect the second White wire to the vehicle's parking light wire.

If the vehicle's parking lights are a chassis ground switched system, connect (1) of the White wires to a chassis ground source, and connect the second White wire to the vehicle's parking light wire.

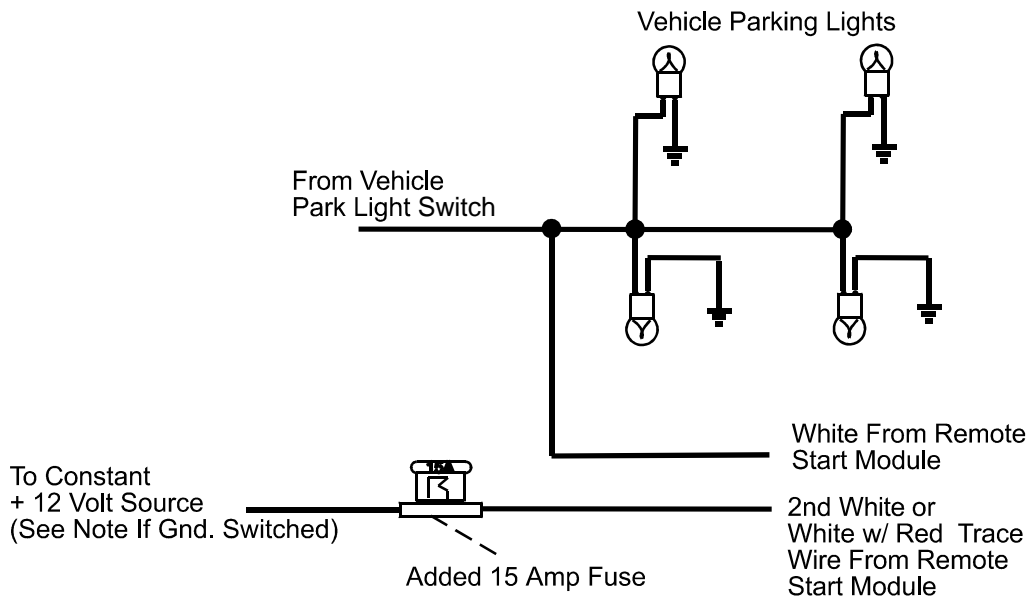

### LIGHT BLUE Wire: Ignition 3 / Shock Disable Output

This wire provides a 300mA ground output that becomes active 3 seconds before the Remote Start Unit initializes, and remains grounded while running plus an additional 4 seconds after the Remote Start Unit turns off. In all of the applications described below, a relay will be required. The Light Blue wire can be used to accommodate the following situations:

#### A. Shock Sensor By Pass:

If there is Shock Sensor used with an alarm system and it is not shunted during the Remote Start activation period, then vibration from the running vehicle can cause the alarm to trigger. In this case, connect the Light Blue Wire to terminal #86 of an external relay. Connect terminal #85 of the relay to a fused + 12 volt battery source. Cut the shock sensor trigger wire and connect one end of the cut wire to terminal #30 and the other end of the cut wire to terminal #87a. Just before the Remote Start unit is activated, the relay contacts will open, preventing the shock sensor's operation until the Remote Start unit shuts off.

#### B. Ignition 3 Output:

Some newer vehicles use a third ignition wire which is required to start and keep the vehicle's engine running. If this is the case, connect the Light Blue wire to terminal #86 of an external relay. Connect terminal #30 & #85 to a fused + 12 volt battery source rated for a minimum of 25 Amp. Connect terminal #87 to the third ignition wire in the vehicle.

#### C. GM VATS Key Override:

If the vehicle has the General Motors VATS system installed, you will need to by-pass the system while the vehicle is operating under the control of the Remote Start Unit. To Do This;

1. Measure the resistance of the resistor pellet on the ignition key then select a resistor within 5% of the key's value from the resistor pack supplied.
2. Locate the pair of VATS wires in the vehicle, usually a pair of thin gauge wires running from the ignition switch to the VATS control module.

**NOTE:** These wires are typically White w/ Black trace and Violet w/ Yellow trace, however in later model Cadillacs, they are run through an orange sleeve, and are either both Black, both Yellow, or both White wires. Consult the factory service manual for additional information.

3. Connect the Light Blue Wire from the Remote Start Unit to terminal #86 of an external relay. Connect terminal #85 of the relay to a fused + 12 volt battery source.
4. Cut (#1) wire (as shown), and connect the ignition switch side of the cut wire to terminal #87a of the relay. Connect the other side of the (#1) wire to terminal #30.
5. Connect the previously selected resistor from terminal #87 to the second (#2) wire (as shown).

**NOTE:** The above information and following diagram is for the GM VATS system only. For GM PASS LOCK System you will require the Audiovox AS-PASS II Module.

### General Motors VATS By-Pass Diagram

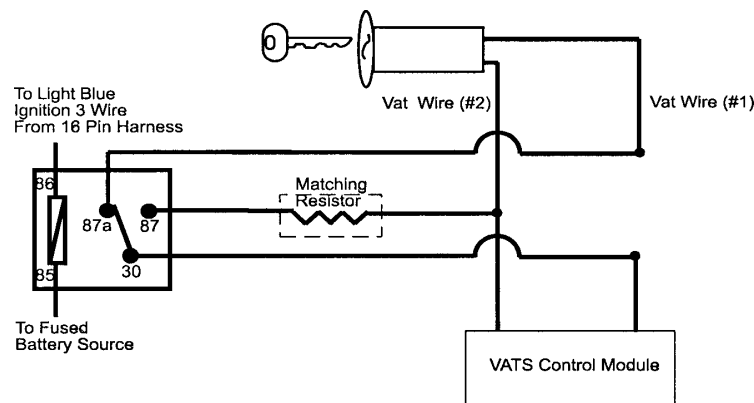

### DARK GREEN Wire: Tach Sensor Input

This wire will continually monitor the engine tach rate while the unit is under power of the Remote Start module. This wire will be routed to the vehicle ECM tach input or through the firewall into the engine compartment and connect to the negative side of the ignition coil. This Remote Start unit learns the tach rate of the vehicle and in most cases will operate properly from one multi coil pack regardless of the number of cylinders. If the vehicle has a single coil unit for each cylinder, it may be necessary to connect this wire to more than one cylinder for proper tach reference. See multi coil wiring detail shown later in this manual for additional information.

### Tachometer Input Wiring Detail

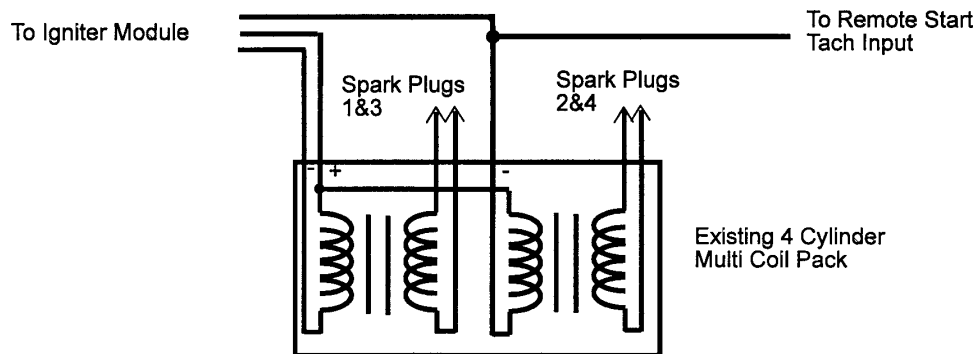

### 2 Pin Door Lock/Unlock Harness: (White Connector)

The Red & Green Door Lock/Unlock output wires provide either a pulsed ground or pulsed + 12 volts to control the vehicle door lock / unlock circuits. The output of these wires has a maximum switching capability of 300mA. Many vehicles today have factory door lock relays which can be connected directly to these outputs, however always confirm that the factory relays in your particular vehicle do not exceed the rated 300mA output of the units door lock/unlock circuit. Plug the two pin connector of the door lock/unlock harness into the mating connector shell of the control module. Determine the door lock circuit of the vehicle you are working on and wire according to the diagrams shown.

### 3 Wire Ground Switched Door Lock Circuits:

In this application, the Red wire of the two pin harness provides a ground pulse during the arming sequence, or pulsed ground lock output. Connect the Red wire to the low current ground signal wire from the factory door lock switch to the factory door lock relay.

The Green wire of the two pin harness provides a ground pulse during the disarming sequence, or pulsed ground unlock output. Connect the Green wire to the low current ground signal wire from the factory door unlock switch to the factory door unlock relay. See Below For Wiring Detail.

### 3 Wire Ground Switched Door Lock/Unlock Wiring Detail

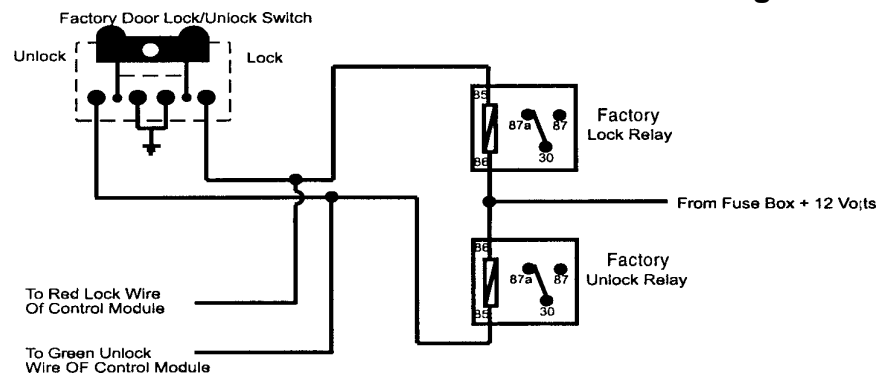



### 3 Wire Positive Switched Door Locks:

In this application, the Red wire of the two pin harness provides a + 12 volt pulse during the disarming sequence, or pulsed 12 volt unlock output. Connect the Red wire to the low current 12 volt signal wire from the factory door unlock switch to the factory door unlock relay.

The Green wire of the two pin harness provides a + 12 volt pulse during the arming sequence or pulsed 12 volt lock output. Connect the Green wire to the low current 12 volt signal wire from the factory door lock switch to the factory door lock relay. See Below For Wiring Detail.

### 3 Wire Positive Switched Door Lock/Unlock Wiring Detail

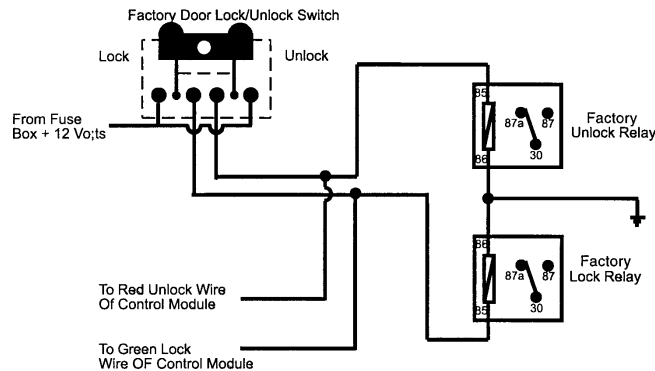

### Resistive Circuits, As Well As 4 Wire Polarity Reversal and 5 Wire Alternating 12 Volt Door Lock Control Circuits

These applications require the use of additional components which may include relays, fixed resistors, or for convenience, the AS 9159 Door Lock Interface. Refer to the AUDIOVOX Door Lock Wiring Supplement and or the Audiovox fax back service for information on your particular vehicle for properly connecting to these types of circuits.

#### 2 Pin Blue Connector : Programming Switch

Route the grey and black wires in the 2 pin connector from the previously installed programming switch to the control module and plug it into the mating blue connector on the side of the module.

### Black/Blue and Green/Yellow- 2 Pin Accessory Harness

#### Black/Blue Wire : 300 mA Pulsed Ground Output

The Black/Blue wire of the two pin connector provides a 1 second pulsed ground output when the unit receives a remote start or unlock command from the transmitter. This output is typically used to disarm a factory alarm. This is a low current 300mA output. If the vehicle you are connecting to requires a more direct ground switch threshold, + 12 volt switching, or more than 300mA ground signal, a relay must be used. In these cases, a relay should be wired as follows: Connect the Black/Blue wire to terminal 86 of the AS-9256 relay (or equivalent 30 A automotive relay), connect terminal 85 to a fused +12 volt source and wire the remaining relay contacts to perform the selected function required of this output.

#### Green/Yellow Wire: Diesel Wait To Start Input

The Green/Yellow wire of the two pin connector will connect to a diesel vehicles glow plug wire. When the unit receives a start command, this wire must go to + 12 then to ground to allow the crank sequence to begin. When ignition 1 is activated by the remote start unit, the glow plug circuit gets energized, (+ 12 volts), when the glow plug circuit of the vehicle drops the + 12 volts, which effectively grounds the wait to start input, then 500mS later the starter will engage. This wire can also be connected to the Glow Plug Bulb wire in the vehicle if this bulb wire gets + 12 volts when the ignition comes on and drops low when the glow plug circuits temperature is reached. If you are installing this unit in a Gasoline vehicle, this wire is not used. Be sure to fuse the wire with a 1 Amp Fuse when connecting to a high current circuit such as a factory glow plug wire. The fuse should be installed as close to the high current wire as possible.

## 1. RF Programmable Features:

Feature Selection	1 Flash	2 Flash	3 Flash	4 Flash	Default
1 Run Time	5 Min.	10 Min.	15 Min.	20 Min.	10 Min.
2 Ign. 2 During Crank	Off	On			On
3 Light Output During Run	Steady	Flash			Steady
4 Tach Mode	NA	Tach			Tach
5 NA	NA	NA	NA	NA	NA
6 Trouble Shooting	Off	On			Off
7 Door Locks	1 Sec/1 Sec	3.5 Sec/3.5 Sec	1 Sec/Db1 1 Sec		1 Sec/1 Sec

### To program these selectable features:

1. Start with the programming switch in the OFF position.
2. Turn the ignition key to the ON position.
3. Flip the program switch ON - OFF - ON - OFF - ON - then OFF.
4. Immediately turn the ignition key OFF, then back to ON.
5. Flip the program switch ON - OFF - ON - then OFF.
6. Use button 2 on the transmitter to advance to the feature that you want to change. EXAMPLE - If you need to change programmable feature number 3, press and release button 2 on the transmitter 3 times in succession. The parking lights will flash 3 times confirming that selected feature 3 can now be programmed.
7. Use button 1 on the transmitter to change the selection of the programmable feature. If you are not sure what the setting for any feature is, press button 1 one time, the parking lights will flash once or twice indicating the features setting.

**Note:** Once you enter the feature programming mode, do not allow more than 15 seconds to pass between steps, or the programming will be terminated.

## 2. Programming Tach Rate:

### NOTE: All applications require that tach be programmed.

The unit will not operate unless tach is programmed. If an attempt is made to start the vehicle via the remote start without first programming tach, the unit will flash the parking lights 7 times indicating tach has not been learned and stored. If the tach rate is not properly programmed to the specific vehicle, the unit may not realize that the vehicle is running in certain instances re-engage the starter motor.

The Remote Car Starter will learn the tach rate of most vehicle's single ignition coils, multiple coil packs, and or single injector. To learn tach;

1. Start with the programming switch in the OFF position.
2. Turn the ignition key to the ON position.
3. Flip the program switch ON - OFF - ON - OFF - ON - then OFF.
4. Immediately turn the ignition key OFF.
5. Flip the program switch ON, then start the vehicle **using the ignition key**.
6. When the unit senses the tach signal, the parking lights will begin to flash.
7. Flip the program switch OFF. The parking lights will turn on for 3 seconds to indicate that the tach signal is stored and the unit is now out of the program mode.

## 3. Diagnostics:

1. Be sure that programmable feature number #6 is set to the "Diagnostics On" mode.
2. First flip the program switch on, then turn the ignition key to the ON position.
3. The lights will flash and the number of flashes will indicate the reason for shutdown on the last remote start attempt.

The indications are as follows.

- |           |  |
|-----------|--|
| 1 Flash   | 5, 10, 15, or 20, minute run timer expired |
| 2 Flashes | Low or no tach signal received.            |
| 3 Flashes | Positive or negative input shut down.      |
| 4 Flashes | Control switch was moved to off position   |
| 5 Flashes | RF Shutdown command received.              |
| 6 Flashes | High RPM signal overspeed shut down        |
| 7 Flashes | Tach has not been learned.                 |

## Multi Coil Pack Adaptor: (Optional)

The multi coil pack adaptor, (P/N 136B1400), is designed for use with vehicles that do not respond to single coil tach programming. Although the tach resolution of this circuit is designed to interface direct with most vehicles, there may be an occasion where the following circuit may be required.

To use the adaptor, the Green/Black wires must connect to the negative side of the ignition coil(s).

1. For vehicles utilizing independent coils per cylinder, connect the three Green/Black leads to alternate coils. To achieve optimum performance the coil signals must be evenly distributed. This is accomplished by first mapping out the firing order of the engine in groups of as indicated below. Draw a circle around any of the columns. The Green/Black wires should be connected to the negative (-) terminal of the respective cylinder number which appears in any of the circles.
2. For vehicles utilizing 2 cylinder firing per coil pack, connect Green/Black to the tach side of each coil pack. For 8 cylinder, four coil systems, connect to any of the three coils.
3. Connect the Yellow wire to a +12 volt ignition 1 source. This wire will have +12 volts with the ignition in the on and start position and have 0 volts with the ignition in the off position.
4. Connect the Green wire to the (Green) or (Orange/Green) tach input of the Audiovox remote start unit.

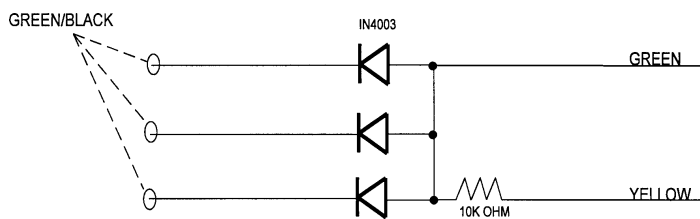

IF THE FIRING ORDER IS 1,8,4,3,6,5,7,2

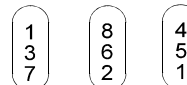

CONNECT TO CYLINDERS 1,3,7, OR 8,6,2, OR 4,5,1

IF THE FIRING ORDER IS 1,5,6,3,4,2,7,8

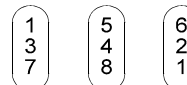

CONNECT TO CYLINDERS 1,3,7 OR 5,4,8 OR 6,2,1

### TESTING YOUR INSTALLATION:

**WARNING!!** The following procedure must be performed after the installation of an Audiovox Remote Start Device. It is the responsibility of the installing technician to complete these tests. Failure to test the unit in the following manner may result in personal injury, property damage, or both.

#### HOOD PIN SAFETY SHUT DOWN:

The intention of the hood pin safety shut down is to prevent the Remote Start unit from being activated while a mechanic or vehicle owner is performing normal routine vehicle maintenance.

To test the integrity of this circuit:

1. With the driver's window in the down position, start the vehicle using the RF transmitter.
2. Reach inside the car and pull the hood release.
3. Raise the hood and confirm that the remote start unit shuts down.

If the unit fails this test, recheck your pin switch connection to the Gray/Black wire of the Audiovox Remote Start Unit.

**DO NOT RELEASE THIS VEHICLE TO THE CONSUMER UNTIL YOU CONFIRM THE OPERATION OF THE HOOD PIN SAFETY SHUT DOWN FEATURE.**

#### MANUAL SHUT DOWN / ENABLE CIRCUIT:

The intent of the manual shut down / enable circuit is to allow the vehicle operator to prevent operation of the Remote Start Unit regardless of the RF transmitter operation.

To test the integrity of the manual shut down / enable circuit:

1. Place the control switch in the on (Closed To Ground) position.
2. Start the vehicle using the RF transmitter.
3. The vehicle should start and run under the control of the remote start unit.
4. Move the switch to the off (Open From Ground) position, the vehicle should shut off.

If the unit fails this test, recheck your enable switch connection to the Ground and the Black/White wire of the Audiovox Remote Start Unit. If you have a plug in enable switch, check that the two pin connector is firmly seated in the mating connector on the control module.

**DO NOT RELEASE THIS VEHICLE TO THE CONSUMER UNTIL YOU CONFIRM THE OPERATION OF THE MANUAL SHUT DOWN / ENABLE FEATURE.**

**NEUTRAL START SAFETY TEST:**

The intent of the neutral start switch is to prevent the vehicle from starting while the gear selector is in any position other than Park, or Neutral. When installing a Remote Start Device, it is imperative that the Yellow Starter wire be connected to the ignition switch side of the Neutral Start Switch. Consideration for the placement of a starter inhibit relay is important as well, and should be connected to the ignition switch side of the Yellow Start Wire.

To test the integrity of the Neutral Start Safety Circuit:

1. Set the vehicle parking brake.
2. Block the drive wheels to prevent vehicle movement.
3. Temporarily disconnect the Brown/Black positive shut down wire from the vehicle's brake switch.
4. Sitting in the vehicle, start the engine using the vehicle's ignition key.
5. Step on the brake pedal and shift the gear selector into reverse.
6. Allow the transmission to shift. When you feel the engine pull, do not move the gear selector just turn the ignition switch off. DO NOT attempt to remove the key.
7. Keeping the brake pedal depressed, activate the RF transmitter in an attempt to start the vehicle. The car should not start.
8. Repeat the above test this time move the gear selector to the drive position. If the unit attempts to start, failing this test, recheck your Yellow Wire's connection. This wire must be connected to the ignition switch side of the Neutral Start Switch. If the vehicle you are working on does not have an Electrical Neutral Safety Switch, it will be necessary to reconfigure the Remote Starts Wiring to accommodate this vehicle. The information concerning the Mechanical Neutral Safety Switch provided below will help you to determine if the vehicle you are working on has this type of safety switch and will provide alternate wiring methods to accommodate this situation.

**WARNING!**  
**REMEMBER TO RECONNECT THE BROWN/BLACK WIRE TEMPORARILY DISCONNECTED IN STEP 3**

**DO NOT RELEASE THIS VEHICLE TO THE CONSUMER UNTIL YOU CONFIRM THE OPERATION OF THE NEUTRAL SAFETY START FEATURE.**

**MECHANICAL NEUTRAL SAFETY SWITCH CONSIDERATIONS:**

Mechanical neutral safety switch configurations differ slightly in that they do not offer the same level of safety when installing a remote start device. Often when the ignition switch is turned off while the gear selector is in any position other than park or neutral, the mechanical function will not allow the key to be turned to the start position or be removed from the ignition cylinder. This configuration prevents mechanical operation while the vehicle is in gear but offers no consideration for electrical operation. Because of this potential problem, this installation requires the additional connection of a safety wire from the remote start device to the vehicle Park/Neutral ECM Input or the vehicle key in sensor. This connection will prevent remote start operation if the key is left in the ignition switch regardless of the gear selectors position.

**PARK / NEUTRAL ECM INPUT:**

The Park / Neutral ECM input is the preferred method of installation. This not only maintains the integrity of the factory circuit, it is also the easiest to install, providing the vehicle you are working on has this ECM input.

The installation required for this application (shown below), indicates the slight reconfiguration of the control switch wiring and the addition of a 4000 series diode. Shown is a typical GM Park/Neutral ECM input circuit. To connect the Audiovox remote start unit to the GM Park / Neutral ECM input:

1. Locate the Orange / Black reference wire in the "C2" connector found at the ECM in GM B Body vehicles or, locate

- the equivalent reference wire in the vehicle you are installing the Audiovox Remote Start Unit in.
2. Connect the Cathode, (Striped) end, of a 4000 series diode to this reference wire.
  3. Connect the Anode, (Non Striped) end, of the diode to one side of the Remote Start enable switch.
  4. Connect the other side of the enable switch to the Black/White enable input wire of the Remote Start unit.
- The reference diagram below shows a typical GM B Body ECM reference wire and how it is to be connected to the Remote Start Unit.

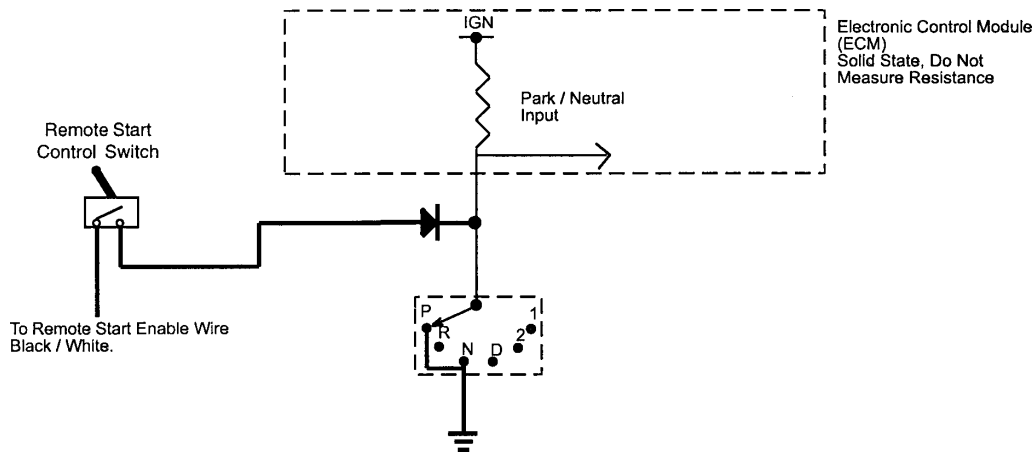

#### KEY IN SENSOR CIRCUITS:

If the vehicle you are working on does not have or you cannot locate the ECM reference wire, there are two alternatives available. Although not preferred, the vehicle Key In Sensor may be reconfigured to allow a margin of safety and will prevent the vehicle with a Mechanical Neutral Start Switch from starting in gear.

**AUDIOVOX ADVISES THAT YOU MAINTAIN THE FACTORY CIRCUIT WHENEVER POSSIBLE.** The following two circuits may be used only if the above circuit is not available.

**NOTE:** When completing an installation using either of the following key in sensor circuits, if the operator inserts the ignition key while the vehicle is running under the control of the Remote Start, the vehicle will shut down. This must be explained to the operator as it is in contrast to the normal operation of a vehicle utilizing an electrical neutral start switch and is inconsistent with the operators manual.

Additional information concerning Key In Sensor methods 1 & 2 are listed below and should be reviewed before considering either alternative.

**Method 1** will allow the safety required for the remote start unit and prevent the vehicle from starting while in any gear other than Park or Neutral while the key is in the ignition cylinder however, if the key is left in the ignition switch and the door is left opened, the added relay will be energized causing a 150mA drain on the battery.

**Method 2** will allow the safety required for the remote start unit and prevent the vehicle from starting while in any gear other than Park or Neutral while the key is in the ignition cylinder however, the original factory key in chime module will not alert the owner that the key has been left in the ignition switch. In addition, this may also effect other warning tones such as the light on reminder.

These situations should be carefully considered before altering the vehicle's wiring and must be fully explained to the consumer.

Circuits may be used only if the above circuit is not available.

To connect to the key in sensor as shown in method 1:

- A. Locate the control wire that connects the drivers door pin switch to the key in sensor switch.
- B. Cut this wire and connect the ignition cylinder side to chassis ground.
- C. Locate the key in sensor switch wire that connects the chime module to the ignition cylinder .
- D. Cut this wire and connect the ignition cylinder side to terminal 30 of a P&B VF45F11 or equivalent relay.
- E. Connect the cathode (striped) side of a 4002 series diode to this same wire, and connect the (non striped) side to the negative shut down safety wire (Gray / Black) of the Audiovox Remote Start Unit.

## METHOD 1

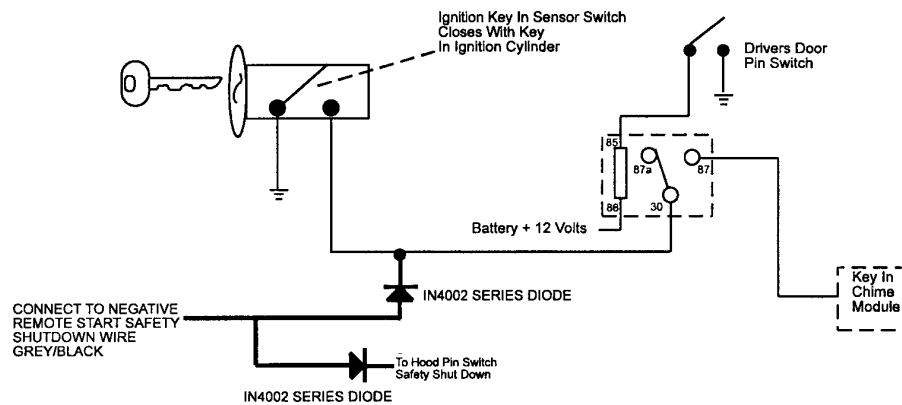

F. Connect terminal 86 of the relay to a fused +12 volt constant battery source.

G. Connect terminal 87 of the relay to the Chime Module side of the previously cut wire in step D.

H. Connect terminal 85 of the relay to the Drivers Door side of the pin switch wire previously cut in step B.

**NOTE:** A second 4002 series diode may be required to maintain the integrity of the hood open, shut down circuit. If this is the case, it must be installed as shown in the diagram above. The anode (Non Striped) side must be connected to the Gray/Black wire of the Remote Start Unit. The cathode (Striped) side must be connected to the hood pin switch. If the hood pin switch is also used for an alarm trigger input, be certain to use the dual diode assembly packaged with the Audiovox Remote Start Unit as shown below.

## METHOD 2

To connect to the key in sensor circuit as shown for method 2:

A. Locate the control wire that connects the drivers door pin switch to the key in sensor switch.

B. Cut this wire and connect the ignition cylinder side to chassis ground.

C. Locate the key in sensor switch wire that connects the chime module to the ignition cylinder .

D. Cut this wire and connect the ignition cylinder side to the Remote Start Negative Safety Shut down Wire Gray/Black, using a 4002 series diode as shown above.

**NOTE:** A second 4002 series diode may be required to maintain the integrity of the hood open, shut down circuit. If

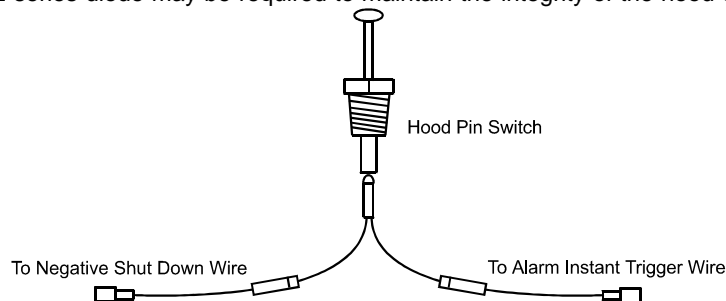

this is the case, it must be installed as shown in the diagram above. The anode (Non Striped) side must be connected to the Gray/Black wire of the Remote Start Unit. The cathode (Striped) side must be connected to the hood pin switch. If the hood pin switch is also used for an alarm trigger input, be certain to use the dual diode assembly packaged with the Audiovox Remote Start Unit as shown in this installation guide.

AFTER THE CONNECTION OF THE NEUTRAL START SAFETY WIRE AS INDICATED IN ANY OF THE PREVIOUS ALTERNATE CONFIGURATIONS, THIS CIRCUIT MUST BE TESTED FOR OPERATION.

Retest by following the steps outlined in the NEUTRAL START SAFETY TEST shown in this manual.

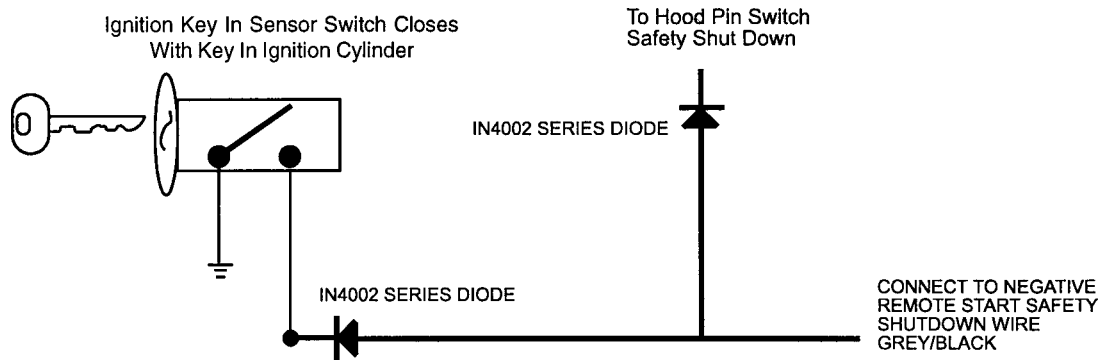

### **COMPLETING THE INSTALLATION:**

After you have confirmed the operation of the Audiovox Remote Start unit and tested all the safety features of the system:

1. If you have not done so already, place the red rubber handle cover over the handle of the control switch for ease of identification. This will allow your customer to distinguish the Remote Start control switch from the program switch.
2. Mount the control module up and behind the dash securing it in place with cable ties or screws. Be certain that the chosen mounting location will not inhibit any of the controls of the vehicle.
3. Securely harness and tie all wiring up and away from all hot and moving parts that they may come in contact with under the dash board or in the engine compartment areas.

**CAUTION:** Particularly avoid the area around the steering shaft and column, as wires can wrap around these mechanisms and impair the safe operation of the vehicle.

4. Apply the Caution Labels supplied with this kit to a conspicuous area in the engine compartment. Make sure to clean the surface before affixing the label.
5. Check the vehicle's wipers, lights, horn, etc.... to insure proper operation.
6. Replace all panels that were removed during installation, and retest the system.
7. Explain all activated features and safety systems associated with Remote Start Unit installed to the customer.

# WIRING DIAGRAM

