

CROWN

PTH 50 Series



The durability leader.

Hands down.



Durability and maneuverability define the PTH 50 Series, meeting the toughest challenges in trailers and across docks.

Don't accept a throw-away design. Superior durability and serviceability keep the PTH 50 Series in the hands of users longer, proving its exceptional value.

Hand pallet trucks don't get the respect they deserve... unless they're built by Crown. The PTH 50 Series may be the smallest truck in the Crown product family, but it gets the same attention to performance and value that sets Crown apart. That includes everything from engineering and design to manufacturing and production testing.

quality and a throw-away design are clear. Crown hand pallet trucks feature solid construction and generous amounts of steel, especially at critical stress points. You'll also appreciate the exceptional ease-of-use and serviceability features.

You can expect more from Crown, because we respect your need for superior performance at the lowest cost of ownership.

Compare the PTH 50 Series with all the others. The differences between Crown

Easy handling makes the PTH 50 Series an ideal solution in retail environments, providing unmatched versatile performance from the back room into the store.



Take advantage of the productivity-enhancing features of the PTH 50 Series.

How does the pump design ensure quality and reduce costs?

- Pump valve tested to over one million cycles
- Valve design minimizes contamination
- Simplified service and parts replacement

Steer and load wheels are engineered with high-quality compounds and bearings for:

- Low rolling resistance
- Easy maneuvering of loads up to 5000 pounds
- Smooth, quiet operation for long-lasting performance

The ergonomic handle reduces fatigue, improves productivity:

- Easy pump action
- Easy maneuvering – neutral lever position releases tension on handle
- Automatic return-to-vertical position when released (safe and efficient)

The 7-inch articulated wheels, designed to maintain optimal contact with the floor, help users easily maneuver across dock plates, in and out of trailers and over uneven floors.

Low fork clearance provides easy entry for multiple pallet types:

- 2.95-inch fork clearance
- Application flexibility, including non-standard pallets

Crown's innovative durability features include:

- Reinforced lower handle
- Forks with C-channel formed steel
- Cross braces and steel forgings on lift link arms
- Box-style push rods
- Yellow chromate pins and shafts (corrosion protection)
- Hard chrome pistons to minimize rust

Service simplicity and lower costs result from:

- Easily replaceable pump valve cartridge
- Snap rings to connect push rods to lift linkage assembly
- Bolt and lock nut used for steer axle mounting
- Crown Integrity Parts®, readily available from your Crown dealer



Pallet entry/exit is easier and faster due to metal ramps on the fork tips and optimally positioned rollers.

Pump it up.
Get unbeatable performance and long-term durability with the PTH 50 Series.

Specifications

Options

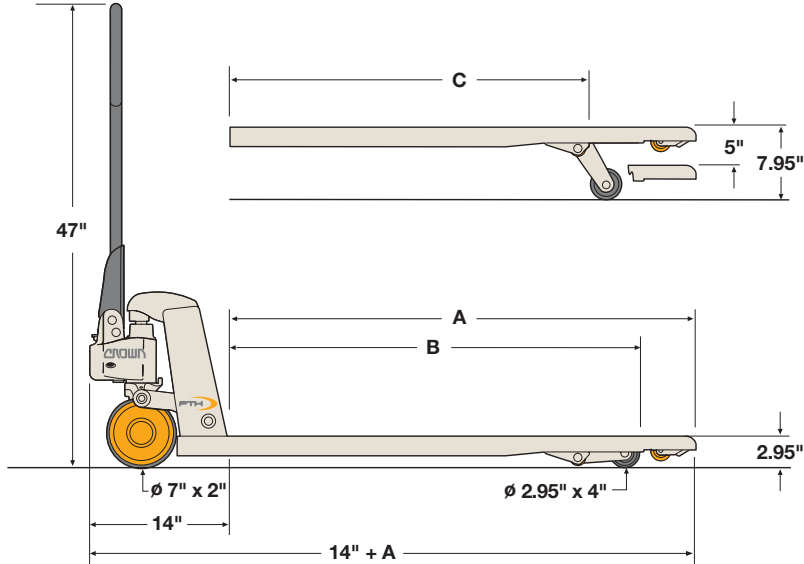
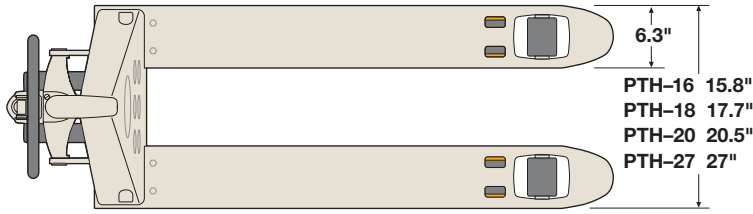

Model	Width	(A) Fork Length	(B) Load Wheel Lowered	(C) Load Wheel Raised	Weight (lb)
PTH 50 16-36	15.8"	36"	29.5"	23.5"	132
PTH 50 18-42	17.7"	42"	35.5"	29.5"	141
PTH 50 18-48	17.7"	48"	41.5"	35.5"	148
PTH 50 20-36	20.5"	36"	29.5"	23.5"	137
PTH 50 20-42	20.5"	42"	35.5"	29.5"	143
PTH 50 20-48	20.5"	48"	41.5"	35.5"	150
PTH 50 27-36	27.0"	36"	29.5"	23.5"	143
PTH 50 27-42	27.0"	42"	35.5"	29.5"	150
PTH 50 27-48	27.0"	48"	41.5"	35.5"	159
PTH 50 27-54	27.0"	54"	47.5"	41.5"	174
PTH 50 27-60	27.0"	60"	53.5"	47.5"	187
PTH 50 27-72	27.0"	72"	65.5"	59.5"	209

Capacity	5000 lb	Polyurethane wheels	
Width of each fork	6.3"	Steer wheels	Ø 7" x 2" wide
Lift	5"	Load wheels	Ø 2.95" x 4" wide



Load Backrest
Constructed of 5/16" steel, backrests are available in 48" and 60" sizes. Bolt-on installation simplifies field retrofits.



Skid Adapter
Increases lowered height to 5.5" to permit skid handling. Raised height increases to 10.5". Adapter latches in vertical position for pallet-handling tasks.



Crown Equipment Corporation
New Bremen, Ohio 45869 USA
Tel 419-629-2311
Fax 419-629-3796
crown.com

You can count on Crown to build lift trucks designed for safe operation, but that's only part of the safety equation. Crown encourages safe operating practices through ongoing operator training, safety-focused supervision, maintenance and a safe working environment. Go to crown.com and view our safety section to learn more.

Because Crown is continually improving its products, specifications are subject to change without notice.

Crown, the Crown logo, the color beige, the Momentum Mark and Crown Integrity Parts are trademarks of Crown Equipment Corporation.

Copyright 2007 Crown Equipment Corporation
SF14847 10/07
Printed in U.S.A.