



# Model 700J

## Installation Guide

# table of contents

---

<b>What Is Included</b> . . . . .	3	<b>Plug-In Harnesses</b> . . . . .	16
<b>Product Description</b> . . . . .	4	Super Bright LED . . . . .	16
<b>Installation Points to Remember</b> . . . . .	4	Valet/Program Switch . . . . .	16
<b>Tools Required</b> . . . . .	5	<b>Optional Sensor Harness, 4-Pin Connector</b> . . . . .	17
<b>Deciding on Component Locations</b> . . . . .	5	<b>Operation Mode Settings</b> . . . . .	17
Siren . . . . .	5	Standard Vehicle Security and	
Control Module . . . . .	6	Operation Features . . . . .	18
Valet/Program Switch. . . . .	6	Level I Security Mode . . . . .	18
Status LED . . . . .	7	Level II Security Mode. . . . .	18
Optional Starter Kill Relay . . . . .	8	<b>Internal Programming Jumpers</b> . . . . .	19
<b>Finding the Wire You Need</b> . . . . .	8	Light Flash Jumper . . . . .	19
Constant 12V . . . . .	8	Level I/Level II Security Mode Jumper. . . . .	20
Switched Ignition. . . . .	8	<b>On-Board Dual Stage Shock Sensor</b> . . . . .	20
(-) Parking Light Wire . . . . .	9	<b>Initializing the System</b> . . . . .	21
Starter Wire . . . . .	9	<b>System Features Learn Routine</b> . . . . .	21
<b>Making Your Connections.</b> . . . . .	10	<b>Feature Descriptions</b> . . . . .	23
Solderless Butt Connections . . . . .	10	<b>Table of Zones</b> . . . . .	24
Solder Connections . . . . .	11	<b>Troubleshooting</b> . . . . .	25
<b>Primary Harness (H1) Wire Connection Guide.</b> 12		<b>Wiring Quick Reference Guide</b> . . . . .	26
Primary Harness Diagram . . . . .	12		
Primary Harness Connection Descriptions . . . . .	12		

*Bitwriter™, Car★Com™, Code Hopping™, Doubleguard®, ESP™, FailSafe®, Ghost Switch™, Learn Routine™, Nite-Lite®, Nuisance Prevention Circuitry®, NPC®, Revenger®, Silent Mode™, Soft Chirp®, Stinger®, Valet®, Vehicle Recovery System®, VRS®, and Warn Away® are all Trademarks or Registered Trademarks of Directed Electronics, Inc.*

# what is included

---

- The control module (see diagram)
- A Revenger® Soft Chirp® siren
- The plug-in Valet®/program switch
- The plug-in status LED
- 12-Pin primary harness
- A Stinger® Doubleguard® shock sensor on-board the control module

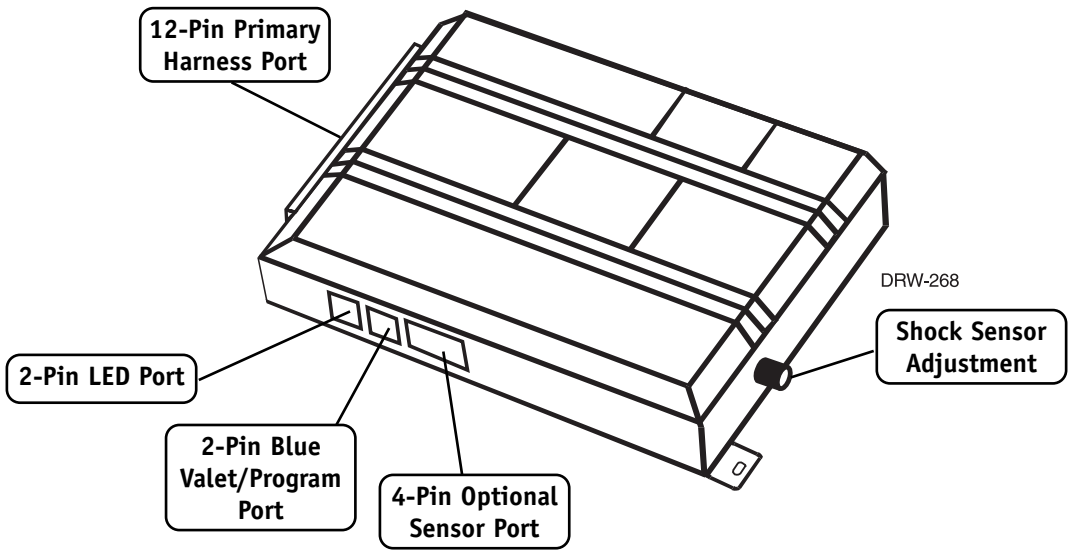

# product description

---

This unit is used to enhance a vehicle's original equipment from manufacturer (OEM) factory keyless entry system by converting it into a full-featured alarm system. It has been designed to work with the factory transmitters and to interface with minimal wiring to the vehicle. The databus interface module interfaces with the vehicle's Class II databus signal wire to arm and disarm the vehicle, and to determine if there has been a vehicle intrusion.

Vehicles with the Class II databus, which can be interfaced with databus interface module are:

- 2000 and newer Cadillac DeVille and Seville
- 2000 and newer Buick LeSabre
- 2001 and newer Oldsmobile Aurora
- 2000 and newer Pontiac Bonneville
- 1999 and newer Jeep Grand Cherokee

# installation points to remember

---

## BEFORE BEGINNING THE INSTALLATION

- Check with the customer to decide on a status LED location.
- Use seat and fender covers to protect the vehicle.
- Remove the domelight fuse. This prevents accidentally draining the battery.
- Roll down a window to avoid being locked out of the car.
- Do not disconnect the battery if the vehicle has an anti-theft coded radio. If equipped with an airbag, avoid disconnecting the battery if possible.
- Remove necessary under-dash trim panels to provide access for mounting the system's components.

**IMPORTANT!** Please read this entire installation guide before beginning the installation. The installation of this security system requires interfacing with many of the vehicle's systems. Many new vehicles use low-voltage or multiplexed systems which can be damaged by low resistance testing devices, such as test lights or logic probes. Test all circuits with a high-quality digital multi-meter before making the connections.

**IMPORTANT!** Many airbag systems will display a diagnostic code through their warning light after they lose power. Disconnecting the battery requires this code to be erased, which can require a trip to the dealer.

## AFTER THE INSTALLATION

- Test all functions. The “Using Your System” section of the Owner’s Guide is very helpful when testing.
- When testing, don’t forget that this system is equipped with Nuisance Prevention Circuitry (NPC). This circuitry can bypass both instant trigger zones, making them appear to stop working.
- Carefully reassemble the under-dash trim panels.
- Inspect the engine compartment for tools that may have been left behind.

# tools required

---

- Digital multi-meter
- Wire cutters/strippers
- Solderless terminal crimpers
- Cordless power drill
- Torx driver set
- Nutdriver and/or socket set
- Panel removal tool
- Drill bit set
- Phillips head screwdriver
- Work light

This is a general list of tools required to complete the installation of this DEI® security system in most vehicles. Some vehicles may require additional tools.

# deciding on component locations

---

## locations for the siren

Some things to remember when mounting the siren:

- Keep it away from heat sources. Radiators, exhaust manifolds, turbochargers, and heat shields are all things to avoid.
- Mount it where a thief cannot easily disconnect it, whether the hood is open or shut. Both the siren and its wires should be difficult to find. This usually involves disguising the wire to look like a factory harness.
- We recommend against grounding the siren to its mounting screws. Instead, we recommend running both the red and black wires into the passenger compartment and grounding to one common point for all devices. After all, both wires are the same length and already come bonded together. Whenever possible, conceal your wires in the factory harnesses or in the same style loom as the factory.
- When possible, put the siren on the same side of the vehicle as the control module, where its wires will reach the control module’s wires without extending them. Always run the wires through the center of a grommet, never through bare metal!

- Point the siren down so water does not collect in it.

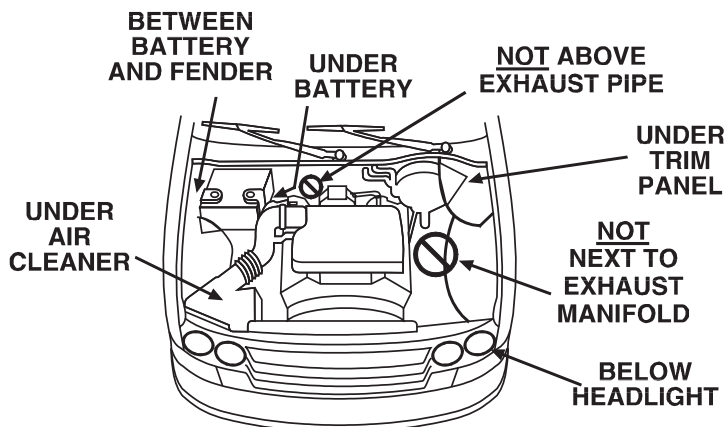

### locations for the control module

- Never put the control module in the engine compartment!
- The first step in hot-wiring a vehicle is removing the driver's side underdash panel to access the starter and ignition wires. If the control module is placed just behind the driver's side dash it can easily be disconnected.
- When locating the control module, try to find a secure location that will not require you to extend the harnesses' wires (they are 1.5 meters long). Keep it away from the heater core (or any other heat sources) and any obvious leaks.
- Some good control module locations: Inside the center console or above the underdash fuse box.

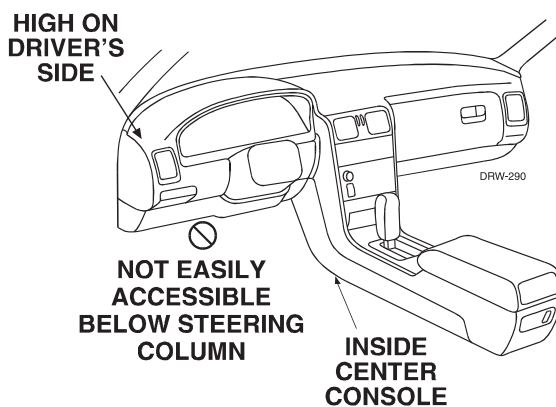

### locations for valet/program switch

Ensure that the location you pick for the switch has sufficient clearance to the rear. The switch should be well hidden. It should also be placed so that passengers or items being stored do not bump it, avoiding places such as the glove box and center console. The switch fits into a  $\frac{9}{32}$ -inch hole.

This system has Remote Valet, so the user can enter and exit Valet Mode without having to reach the Valet/program switch. DEI introduced this feature so that switch location was less critical in day-to-day use. As long as the Valet/program switch can be reached to disarm without a transmitter, easy access is not important.

**IMPORTANT!** When the vehicle is delivered, please show the user where the switch is located and how to disarm the system with it.

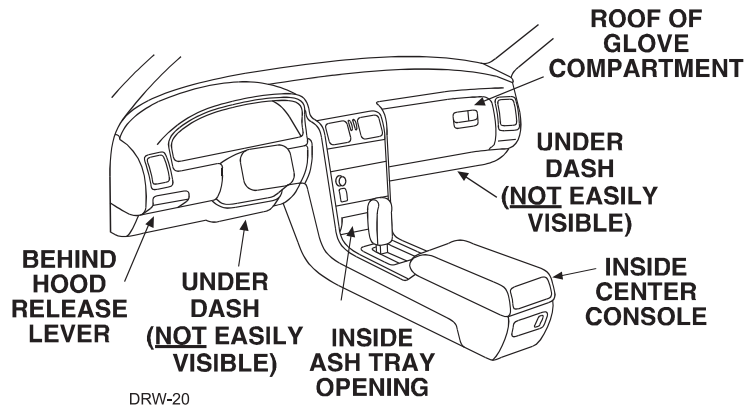

### locations for the status LED

Things to remember when positioning the Status LED:

- It should be visible from both sides and the rear of the vehicle, if possible.
- It needs at least  $\frac{1}{2}$ -inch clearance to the rear.
- It is easiest to use a small removable panel, such as a switch blank or a dash bezel. Remove it before drilling your  $\frac{9}{32}$ -inch hole.
- Use quick-disconnects near the LED wires if the panel is removable. This allows mechanics or other installers to remove the panel without cutting the wires.

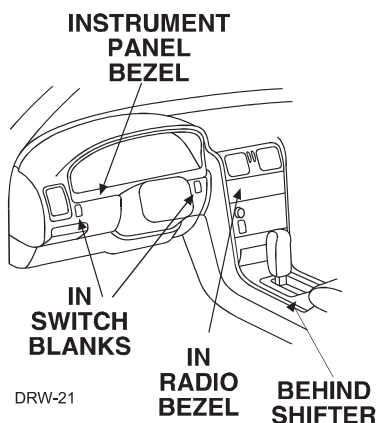

## optional starter kill relay

If the optional Failsafe® Starter Kill Relay (not included with this unit) or its connections are immediately visible upon removal of the underdash panel, they can easily be bypassed by a thief. Always make the relay and its connections difficult to discern from the factory wiring! Exposed yellow butt connectors do not look like factory parts, and will not fool anyone! For this reason, routing starter kill wires away from the steering column is recommended.

# finding the wires you need

Now that you have decided where each component will be located, you're going to find the vehicle wires that the security system will be connected to.

**IMPORTANT!** Do not use a 12V test light to find these wires! All testing described in this manual should be performed with a digital multimeter.

## obtaining constant 12V

We recommend two possible sources for 12V constant: The (+) terminal of the battery, or the constant supply to the ignition switch. Always install a fuse within 12 inches of this connection.

**IMPORTANT!** Do not remove the fuse holder on the red (H1/11) wire. It ensures that the control module has its own fuse, of the proper value, regardless of how many accessories are added to the main power feed.

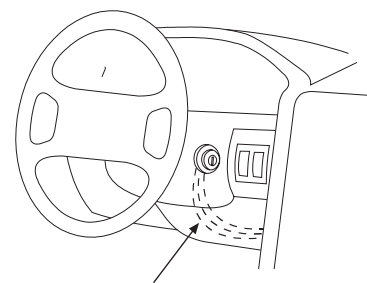
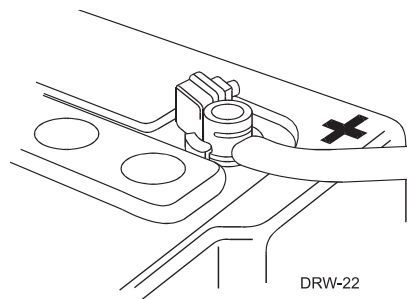
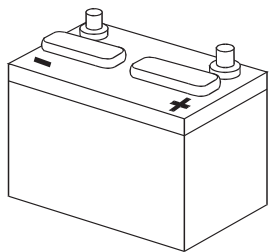

## finding the 12V switched ignition wire

The ignition wire is powered when the key is in the run or start position. This is because the ignition wire powers the ignition system (spark plugs, coil) as well as the fuel delivery system (fuel pump, fuel injection computer). Accessory wires, on the other hand, lose power when the key is in the start position to make more current available to the starter motor.



### How to find (+)12V ignition with your multimeter:

1. Set to DCV or DC voltage (12V or 20V is fine).
2. Attach the (-) probe of the meter to chassis ground.
3. Probe the wire you suspect of being the ignition wire. The steering column harness (ignition switch harness) is an excellent place to find this wire.
4. Turn the ignition key switch to the run position. If your meter reads (+)12V, advance to Step 5. If your meter does not read (+)12V, probe a different wire.
5. Now turn the key to the start position. The meter display should remain steady, not dropping by more than a few tenths of a volt. If it drops close to or all the way to zero, go back to Step 3. If it stays steady at (+)12V, you have located an ignition wire.

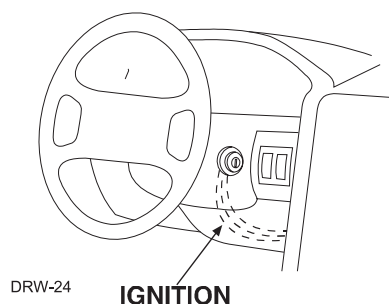

### finding a (-) parking light wire

The (-) parking light wire is often found near the switch or at the dash integration module (DIM). Many cars have the switch built into the turn signal lever, and in these cars the parking light wire can be found in the steering column.

### How to find a (-) parking light flash wire with your multimeter:

1. Set to DCV or DC voltage (12V or 20V is fine).
2. Attach the (+) probe of the meter to a constant +12V source.
3. Probe the wire you suspect of being the parking light wire. Usually, the area near the headlight/parking light switch is an excellent area to start.
4. Turn on the parking lights. If your meter shows 12V, turn off the parking lights and make sure it goes back to zero.

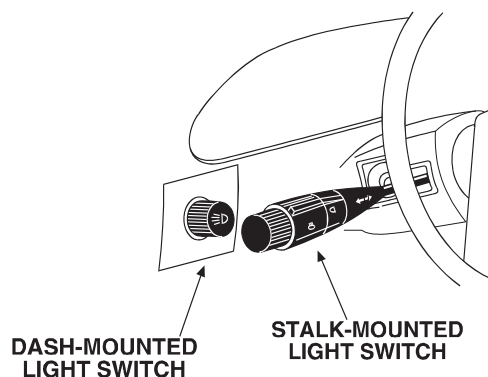

### finding the starter wire

### How to find the starter wire with your multimeter:

1. Set to DCV or DC voltage (12V or 20V is fine).
2. Attach the (-) probe of the meter to chassis ground.
3. Probe the wire you suspect of being the starter wire. The steering column is an excellent place to find this wire. Remember you do not need to interrupt the starter at the same point you test it. Hiding the optional starter kill relay and connections is always recommended.
4. Make sure the vehicle is not in gear! Turn the ignition key switch to the start position. If your meter reads (+)12V, go to the next step. If it doesn't, probe another wire.
5. Cut the wire you suspect of being the starter wire.
6. Attempt to start the car. If the starter engages, reconnect it and go back to Step 3. If the starter does not turn over, you have located the correct wire.

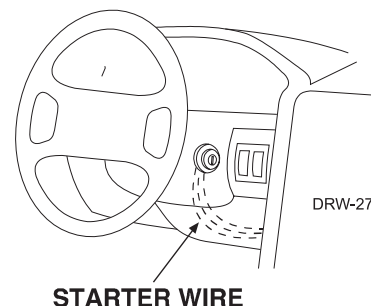

# making your connections

---

When connecting the security system's wires to the vehicle wires it is important that the connections are tight and no bare wire is exposed. In this section, two types of connections are described that may be used to connect the wires from the security system to the vehicle's wiring. Both types of connections are electrically acceptable if made correctly. Other types of "tap-in" connections, such as T-Taps are not acceptable.

## solderless butt connections

1. Cut the wire and strip back about  $\frac{1}{4}$ -inch of insulation on each end of the wire.

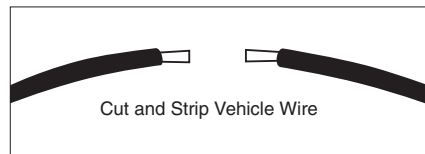

2. Twist one end of the vehicle's wire with the security module's wire.

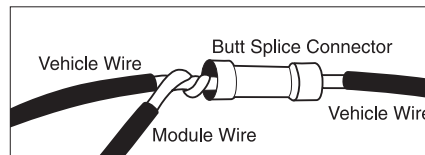

3. Insert the twisted pair of wires into one end of the butt connector and crimp securely.

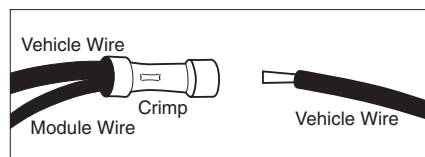

4. Insert the other end of the vehicle's wire into the other end of the butt connector and crimp securely.

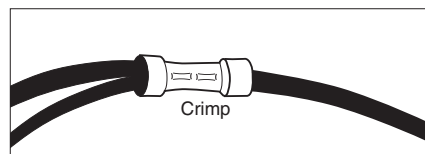

## solder connections

1. Using your wire strippers and razor knife, strip approximately  $\frac{1}{2}$ -inch of insulation off the wire to be connected to, without cutting the wire.

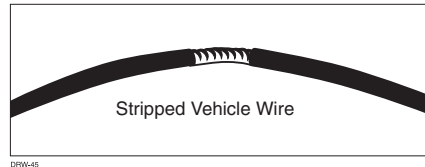

2. Twist the security module's wire around the bare section of the vehicle's wire.

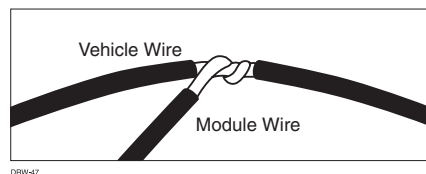

3. Solder the bare connection thoroughly using rosin core solder.

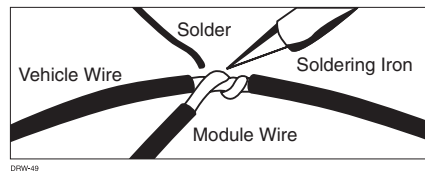

4. Completely insulate the connection with electrical tape.

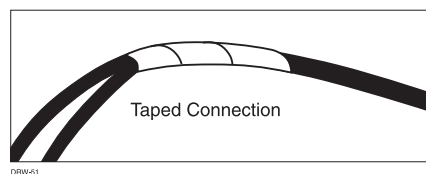

# primary harness (H1) wire connection guide

This section of the installation guide describes in detail the connection of each of the primary harness wires. Also included are possible applications of each wire. This system was designed with the ultimate in flexibility and security in mind. Many of the wires have more than one possible function. Please read carefully to ensure a thorough understanding of this unit.

## primary harness diagram

H1/1	ORANGE	(-) 500 mA GROUND-WHEN-ARMED OUTPUT
H1/2	WHITE	(-/+ ) SELECTABLE LIGHT FLASH OUTPUT
H1/3	WHITE/BLUE	(+) TRUNK RELEASE, SENSOR SHUNT INPUT
H1/4	BROWN/BLACK	(-) 200 mA HORN HONK OUTPUT
H1/5	YELLOW/BLACK*	DATABUS CONNECTION
H1/6	BLUE	(-) INSTANT TRIGGER INPUT, ZONE 1
H1/7	OPEN	NO WIRE
H1/8	BLACK	(-) CHASSIS GROUND INPUT
H1/9	YELLOW	(+) IGNITION INPUT
H1/10	BROWN	(+) SIREN OUTPUT
H1/11	RED	(+) 12V CONSTANT POWER INPUT
H1/12	RED/WHITE	(-) PROGRAMMABLE AUXILIARY CHANNEL/DELAYED ACCESSORY OUTPUT

**\*IMPORTANT!** The databus connection wire should only be connected to the vehicle's databus signal wire. Do not connect this wire to anything else.

## primary harness connection descriptions

### H1/1 ORANGE (-) GROUND-WHEN-ARMED OUTPUT

This wire supplies a (-)500 mA ground as long as the system is armed. This output ceases as soon as the system is disarmed. The orange wire may be wired to an optional DEI® 8618 starter kill relay.

### H1/2 WHITE (-/+ ) SELECTABLE LIGHT FLASH OUTPUT

As shipped, with the light flash polarity jumper inside the unit in its default position (see the *Internal Programming Jumpers* section of this guide), this wire supplies a (-) 200 mA output, which is suitable for driving a negative (-) parking light relay.

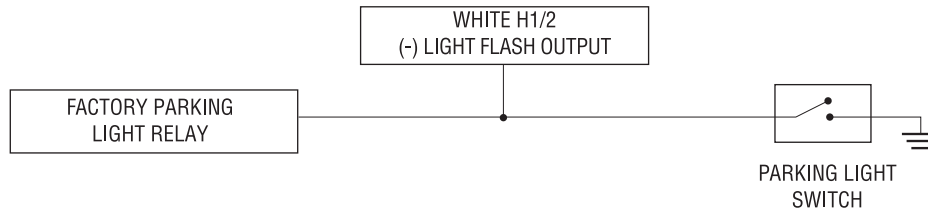

If the light flash polarity jumper inside the unit is moved to the opposite positive (+) position (see the *Internal Programming Jumpers* section of this guide), this wire supplies a (+) 200 mA output, which is suitable for driving (+) parking light wires.

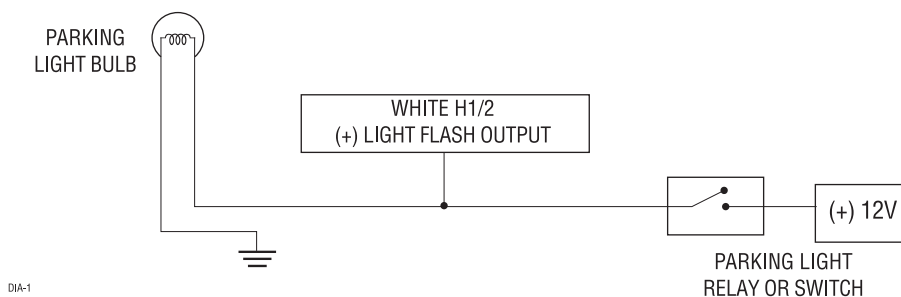

### H1/3 WHITE/BLUE (+) TRUNK RELEASE, SENSOR SHUNT INPUT

This input is used to bypass sensor inputs when the trunk is opened using the factory transmitter. Connect this wire to the (+) trunk release output of the factory keyless entry system or trunk release relay. When the system receives a (+) input on this wire, Zones 2 and 4 are bypassed for three seconds. If ground is applied to the H1/6 BLUE wire during that three-second period, Zones 2 and 4 will remain bypassed until the ground input is removed. This means that when the trunk is opened with the factory transmitter, the only triggers that remain active while the trunk is open are the doors. Five seconds after the trunk is closed, the bypassed zones will become active again.

**NOTE:** This connection is not required with most Class II databus systems.

### H1/4 BROWN/BLACK (-) 200 mA HORN HONK OUTPUT

This wire supplies a (-) 200 mA output that can be used to honk the vehicle's horn. It provides a pulsed output when the security system is in the triggered sequence or in Panic Mode. In most vehicles with (-) horn circuits, this wire can control the vehicle's horn without adding a relay. If the vehicle has a (+) horn circuit, an optional relay must be used to interface with the horn circuit.

**IMPORTANT!** Never use this wire to drive anything except a relay or a low-current input! This transistorized output can only supply (-) 200 mA. Connecting directly to a high current device will cause the module to fail.

### H1/5 YELLOW/BLACK DATABUS CONNECTION

The databus wire is a wire that connects to the vehicle's network of control modules and allows communication throughout the vehicle. This wire is located at Pin #2 of the diagnostic plug or the On-Board Diagnostic II (OBD II) connector located under the dash in the driver's compartment. (See diagram below.) This wire carries a low voltage data signal and CANNOT be tested. Connect this wire to the databus signal wire in the vehicle. On GM vehicles, the data plug wire is usually purple. On Jeep Grand Cherokees, the data plug wire is usually yellow/black or yellow/purple. The databus connector is usually located to the left of the steering column under the driver's side dash.

DIAGNOSTIC/OBD II CONNECTOR

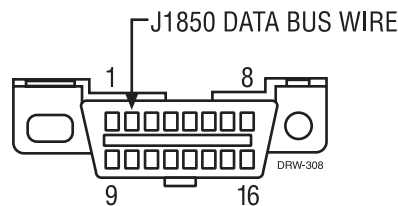

**IMPORTANT!** The databus connection wire should only be connected to the databus signal wire in the vehicle. Do not connect the H1/5 YELLOW/BLACK wire to any other wire!

### H1/6 BLUE (-) INSTANT TRIGGER, ZONE 1

This input will respond to a negative input with an instant trigger. It is ideal for hood and trunk pins or vehicles without factory Content Theft Deterrent (CTD). Vehicles without CTD may require trunk pins or need to be hard-wired to the alarm. (A trunk pin wire may need to be added if the vehicle does not already have a factory trunk pin.) The H1/6 BLUE wire will report on Zone 1.

**NOTE:** Factory CTD systems in Bonneville, Auroras and LeSabres do not monitor the trunk pin wire. For Level I security mode, the H1/6 BLUE wire must be hard-wired to the vehicle's factory trunk pin wire. This step is not required if Level II security mode is selected.



### H1/8 BLACK (-) CHASSIS GROUND CONNECTION

Remove any paint and connect this wire to bare metal, preferably with a factory bolt rather than your own screw. (Screws tend to either strip or loosen with time.) We recommend grounding all your components, including the siren, to the same point in the vehicle.

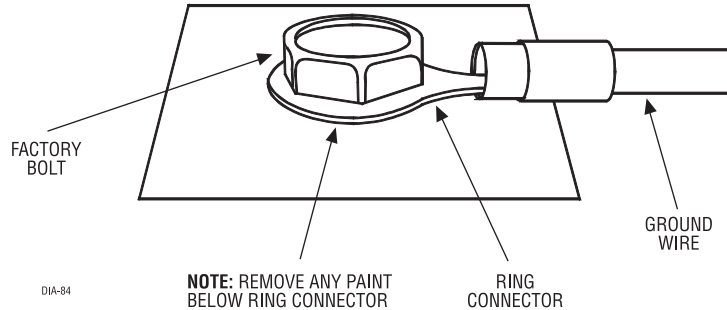

### H1/9 YELLOW (+) IGNITION INPUT

Connect this wire to the (+)12V ignition wire. This wire must show (+)12V with the key in run position and during cranking. Take care to insure that this wire cannot be shorted to the chassis at any point.

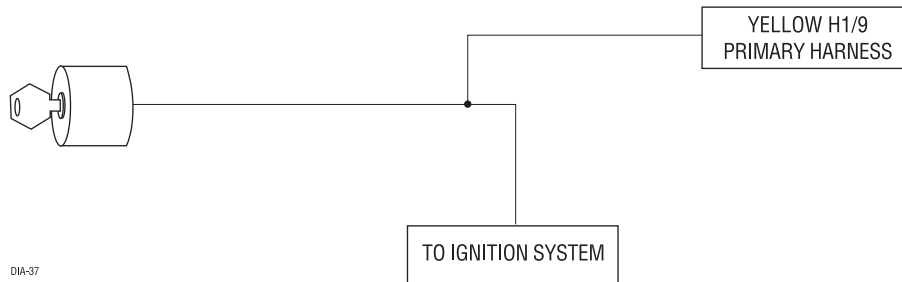

### H1/10 BROWN (+) SIREN OUTPUT

Connect this wire to the red wire of the siren. Connect the black wire of the siren to (-) chassis ground, preferably at the same point that you connect the control module's black ground wire.

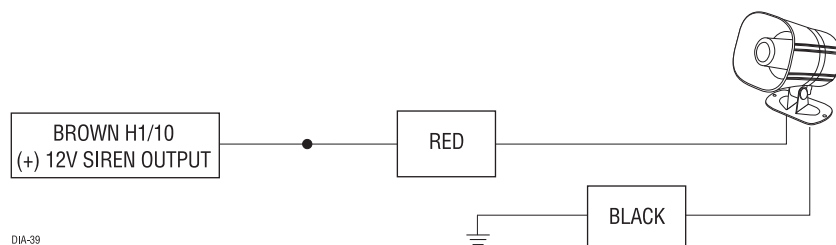

## H1/11 RED (+) 12V CONSTANT POWER INPUT

Before connecting this wire, remove the supplied fuse. Connect to the positive battery terminal or the constant 12V supply to the ignition switch.

**NOTE:** Always use a fuse within 12 inches of the point you obtain (+)12V. Do not use the 15A fuse in the harness for this purpose. This fuse protects the module itself.

## H1/12 RED/WHITE PROGRAMMABLE (-) 200 mA AUXILIARY CHANNEL/DELAYED ACCESSORY OUTPUT

If programmed for the default setting, this wire will provide a (-) pulse when the lock button on the factory transmitter is pressed twice within three seconds. This output can be used to control optional accessories. If programmed for delayed accessory output, this wire will provide (-) ground when the ignition is turned off and will continue to output (-) ground until a door is opened and then closed. This can be used to energize the accessory circuit in the vehicle to keep the radio and other accessories on after the ignition is turned off.

**IMPORTANT!** Never use this wire to drive anything except a relay or a low-current input! This transistorized output can only supply (-) 200 mA, and connecting directly to a solenoid, motor, or other high-current device will cause the module to fail.

# plug-in harnesses

---

### super-bright LED, 2-pin white plug

The LED operates at 2V DC. Make sure the LED wires are not shorted to ground because the LED will be damaged. The LED fits into a  $\frac{9}{32}$ -inch mounting hole. Be sure to check for clearance prior to drilling the mounting hole.

### valet/program switch, 2-pin blue plug

The Valet/program switch should be accessible from the driver's seat. It plugs into the 2-pin blue port of the control module. Since the system features Valet by remote, the Valet switch can be well hidden. Consider how the switch will be used before choosing a mounting location. Check for rear clearance before drilling a  $\frac{9}{32}$ -inch hole and mounting the switch. The GRAY wire in the two-pin plug may also be used as a (+) Ghost Switch input and can be connected to any positive (+) switch in the vehicle (see *Feature 9* in the *Feature Descriptions* section of this guide).

**NOTE:** Please note for the customer the location of the Valet/program switch in the section provided in the Owner's Guide.



# optional sensor harness, 4-pin connector

---

The four-pin shock sensor harness is optional and is not included with this unit. It can be used to add a Glass Breakage Sensor (P/N 506T) or other optional sensors.

## **RED WIRE**

The red wire supplies constant power to the optional sensor.

## **BLACK WIRE**

The black wire supplies ground to the optional sensor.

## **BLUE AND GREEN WIRES**

The blue and green wires are multiplex inputs. They are both tied to the same zone. If an input of less than 0.8 seconds is supplied to either wire, the Warn-Away response will occur. An input longer than 0.8 seconds to either wire will initiate the triggered sequence and report Zone 4.

# operation mode settings

---

## **standard vehicle security and operation features**

### **ARMING AND DISARMING WITH THE OEM TRANSMITTER**

When connected to the vehicle's databus, the interface module can be armed and disarmed with the OEM keyless entry transmitter by pressing the lock and unlock buttons, respectively.

### **SENSOR SHUNT AND TRUNK TRIGGER BYPASS WITH THE OEM TRANSMITTER**

The trunk trigger and on-board shock sensor are bypassed when the trunk release button is pressed on the OEM transmitter, allowing trunk access while the rest of the vehicle's security system remains armed. This shunt feature will continue until 5 seconds after the trunk has been closed, at which point the trunk trigger and shock sensor will become active again.

### **INTRUSION PROTECTION**

There is no need to hard-wire the door triggers — the vehicle's door triggers, and in some applications the trunk trigger, are monitored by the interface module through the vehicle's databus. The databus interface module will

detect both vehicle intrusions and faulty zones. For vehicles that do not have a trunk pin, or if the pin is not monitored by the vehicle's databus, the trunk can be hard-wired to the databus interface module.

### level I security mode

Level I security is the default security mode setting (see the *Internal Programming Jumpers* section of this guide). In Level I security mode, the standard vehicle security and operation features are monitored (see previous paragraphs for descriptions). In addition to the standard features, there are additional features available in this mode:

#### DOOR KEY DISARM FEATURE

The databus interface module can be disarmed using the driver and passenger door key cylinder, if available (not all vehicles have a passenger door key cylinder).

#### SENSOR SHUNT AND TRUNK TRIGGER BYPASS WITH THE TRUNK KEY CYLINDER

Similar to sensor shunt and trunk trigger bypass with the OEM transmitter, this feature allows trunk access using the trunk key, while the rest of the vehicle's security system remains armed. This shunt feature will continue until 5 seconds after the vehicle's trunk has been closed, at which point the trunk trigger and shock sensor will become active again.

**NOTE:** *Factory content theft deterrent (CTD) systems in Bonneville, Auroras and LeSabres do not monitor the trunk key cylinder wire; therefore, the trunk key cylinder sensor bypass feature is not available on these vehicles. The alarm will trigger if the factory trunk release feature on the OEM transmitter is not used when accessing the trunk while the databus interface module is armed. In Level I security mode, the H1/6 BLUE wire must be hard-wired to the vehicle's trunk pin wire.*

#### VEHICLES WITHOUT CONTENT THEFT DETERRENT (CTD) AND CTD SYSTEMS THAT DO NOT MONITOR THE FACTORY TRUNK PIN

Level I security mode is not recommended for vehicles without CTD. The databus of vehicles without CTD may not monitor the key cylinders. Additionally, most vehicles without CTD do not have trunk pins, which would require adding a trunk pin or hard-wiring the trunk to the databus interface module. Also, when Level I Security Mode is used in vehicles such as Bonneville, Auroras and Lesabres, which have CTD systems that do not monitor the factory trunk pin, the H1/6 BLUE wire must be hard-wired to the vehicle's factory trunk pin wire.

### level II security mode

Level II security can be selected by moving the Level I Security Mode/Level II Security Mode jumper (see the *Internal Programming Jumpers* section of this guide) to the proper position. Level II security is a high security setting in which the door key and trunk cylinders are not monitored by the databus interface module. The only

means of disarming the databus interface module is through the OEM transmitter or coded Valet switch. (Refer to the *Disarming Without a Transmitter* section in the owner's guide for detailed instructions.) Level II security protects the vehicle from unauthorized coded keys being used to open the vehicle's doors or trunk. This security mode also protects the vehicle in cases where one of the key cylinders has been forced and turned to unlock the vehicle.

**VEHICLES WITHOUT CONTENT THEFT DETERRENT (CTD)**

Level II security mode is recommended for vehicles without CTD, which do not monitor key cylinders and often require adding trunk pins or hard-wiring the trunk to the databus interface module.

**CTD SYSTEMS THAT DO NOT MONITOR THE FACTORY TRUNK PIN**

When Level II Security Mode is selected for Bonneville's, Auroras or LeSabres, no additional wiring to the vehicle's factory trunk pin is required.

# internal programming jumpers

---

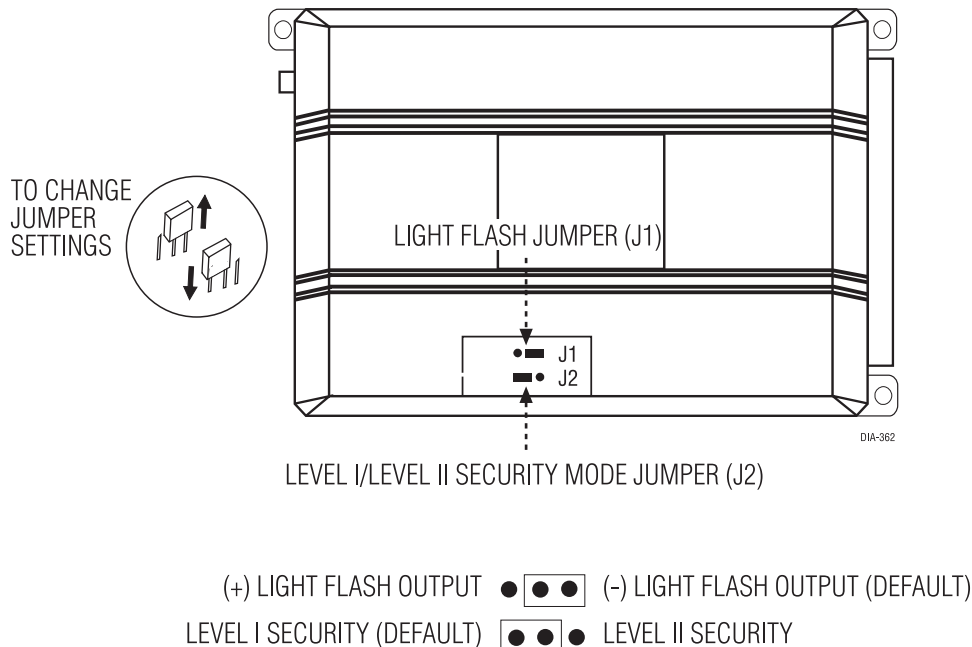

**light flash jumper**

To access the jumper, open the control module. This jumper is used to determine the light flash output. In the default negative (-) position, the on-board relay is disabled and the unit will output (-) 200 mA, suitable for

driving factory parking light relays. In the (+) position, the on-board relay is enabled and will supply a positive (+)12V on the H1/2 WHITE wire.

**NOTE:** For parking light circuits that draw 10 amps or more, the internal jumper must be switched to a (-) light flash output. **P/N 8617** or a standard automotive SPDT relay must be used on the H1/2 light flash output harness wire.

### level I security mode/level II security mode jumper

This jumper is used to select either Level I security mode or Level II security mode.

#### LEVEL I SECURITY MODE

In its default position, this jumper is set for Level I security mode. In Level I security mode, the databus interface module will allow the security system to be disarmed from the driver's door key cylinder. This setting will also allow the trunk trigger zone to shunt if opened using the vehicle's OEM transmitter or trunk key cylinder. If the trunk is forced open, the trunk will trigger only if the vehicle has OEM security content theft deterrent (CTD).

#### LEVEL II SECURITY MODE

When this jumper is moved to the Level II position, the databus interface module will not disarm from the driver's door or passenger door key cylinder. The trunk trigger zone will shunt if opened using the transmitter but will trigger when the key is used or if the trunk is forced open, regardless of whether the vehicle has OEM security content theft deterrent (CTD). Level II security mode can be used for higher security; however, the Valet/program switch must be installed to ensure that if the transmitter is lost, stolen, or damaged, the switch can be accessed to override the system.

## on-board dual stage shock sensor

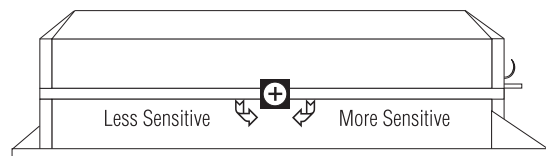

There is a dual-stage shock sensor inside the control unit. Adjustments are made via the rotary control as indicated above. Since the on-board shock sensor does not work well when mounted firmly to metal, we recommend against screwing down the control module. Instead, we recommend mounting the control module to a large wiring loom.

**NOTE:** When adjusting the sensor, it must be mounted in the same location where it will be after the installation is complete. Adjusting the sensor and then relocating the module may require readjustment.

# initializing the system

---

Before initializing the databus interface module, make sure that the power, ground, ignition and the databus input wires are connected to the vehicle.

1. Cycle the ignition key on and then back off again.
2. Close all the vehicle doors.
3. Cycle the doors and trunk using the first OEM transmitter.
4. Repeat the door and trunk cycle for each transmitter programmed to the OEM keyless entry.

# system features learn routine

---

The System Features Learn Routine dictates how the unit operates. It is possible to access and change any of the feature settings using the Valet/program switch.

**To enter the System Features Learn Routine:**

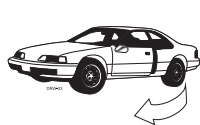

1. **Open a door.**



2. **Key.** Turn the ignition on, and then off. (The H1/9 YELLOW wire must be connected.)

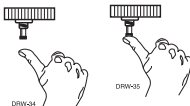

3. **Select a feature:** Press and release the Valet/program switch the number of times corresponding to the feature you wish to program. (See the following table of features.) For example, to access the third feature, press and release three times. Then press the button once more and **HOLD** it. The siren will chirp the number of times corresponding to the feature you have accessed.

FEATURE NUMBER	DEFAULT ONE-CHIRP SETTINGS (PRESS TRANSMITTER LOCK BUTTON OR DOOR LOCK SWITCH)	TWO-CHIRP SETTINGS (PRESS TRANSMITTER UNLOCK BUTTON OR DOOR UNLOCK SWITCH)
1	<b>Active Arming</b>	Passive Arming
2	<b>Confirmation Chirps ON</b>	Confirmation Chirps OFF
3	<b>Siren duration 30 seconds</b>	Siren duration 60 seconds
4	<b>Instant door trigger</b>	delayed door trigger
5	<b>Door trigger error chirp ON</b>	Door trigger error chirp OFF
6	<b>Sensor shunt Zones 2 and 4</b>	Sensor shunt all zones
7	Panic Mode enabled	<b>Auxiliary output enabled</b>
8	No function	
9	<b>Valet switch input 1 pulse</b>	Valet switch input 2-5 pulses

**NOTE:** Factory defaults are indicated in **bold** type.



4. **Program the feature:** While **HOLDING** the Valet/program switch, you can toggle the feature on and off using the remote transmitter. Pressing the button that locks the door will select the one-chirp (default) setting. Pressing the unlock button will select the two-chirp setting.

**NOTE:** Feature 9 (Valet pulse count) has five possible settings. Pressing the unlock button will toggle through all the possible settings.



5. **Release the Valet/program switch.**

#### ONCE THE FEATURE IS PROGRAMMED

- Other features can be programmed.
- The Learn Routine can be exited if programming is complete.

#### TO ACCESS ANOTHER FEATURE

After you have programmed a feature in Step 4 of the learn routine, press and release the Valet/program switch the number of times necessary to advance from the feature you just programmed to the next one you want to program. Then press the Valet/program switch once more and **HOLD** it. For example, if you just programmed the third feature and you would like to program the seventh feature in the menu, you would: Press and release the Valet/program switch four times. Then press it once more and **HOLD** it. The siren would chirp seven times to confirm access to the seventh feature.

## TO EXIT THE LEARN ROUTINE, DO ONE OF THE FOLLOWING:

- Close the open door.
- Turn the ignition on.
- No activity for longer than 15 seconds.
- Press the Valet/program switch too many times.

# feature descriptions

---

**1 ACTIVE/PASSIVE ARMING:** When active arming is selected, the system will only arm when the transmitter is used. When set to passive arming, the system will arm automatically 30 seconds after the last door is closed. To alert the consumer of passive arming, the siren will chirp and the parking lights will flash 30 seconds after the door is closed.

**2 AUDIBLE ARM/DISARM CONFIRMATION ON/OFF:** This feature controls the chirps that confirm the arming and disarming of the system. In the ON setting (default) the siren will provide audible confirmation when arming and disarming the system. If programmed to the OFF position no siren chirps will be heard when arming and disarming.

**3 SIREN DURATION 30/60 SECONDS:** In the default setting, the full triggered sequence will continue when triggered for 30 seconds. This can be changed to 60 seconds in the system features learn routine.

**4 DOOR TRIGGER INSTANT/DELAYED:** In the instant (default) setting, if a door is opened while the security system is armed the system will trigger immediately. In the delayed setting there is a 15-second delay before the doors will trigger the system. This allows the user 15 seconds to disarm the system after a door is opened without the factory transmitter.

**5 DOOR TRIGGER ERROR CHIRP ON/OFF:** With the door trigger error chirp programmed off, the system will not report an invalid zone on arming when the door trigger wire is active. This eliminates the extra chirps that occur when interfacing with vehicles that have exceptionally long dome light delay circuits.

**6 SENSOR SHUNT ZONES 2 and 4/ALL ZONES:** In the default setting all sensors, with the exception of the door zone, will be bypassed when a trigger is grounded three seconds after the trunk is opened (i.e. when there is a (+) pulse on the WHITE/BLUE wire). If this feature is programmed to the all zones setting, all zones, including the doors, will be bypassed when the trunk is opened with the factory transmitter.

**7 PANIC/AUXILIARY OUTPUT:** When this feature is programmed for Panic Mode (default setting), pressing the lock button on the factory transmitter twice within three seconds will trigger Panic Mode. In this setting, the H1/12 RED/WHITE wire becomes a delayed accessory output. This wire will provide (-) ground when the ignition is turned off and will continue to output (-) ground until a door is opened. This can be used to energize the

accessory circuit in the vehicle to keep the radio and other accessories on after the ignition is turned off. If programmed to the auxiliary output setting, pressing the lock button twice within three seconds will send a (-) pulse on the RED/WHITE auxiliary output wire.

**8 NO FUNCTION**

**9 VALET PULSE COUNT 1-5 PULSES:** The system can be programmed to count the number of presses of the Valet switch before disarming the security system. The factory default setting is one pulse. The unit can be set for 2-5 pulses using the unlock button on the transmitter to select the setting.

***GHOST SWITCH OPTION:** For added security, the GRAY wire on the two-pin Valet/program switch can be connected to any switch in the vehicle that provides a positive (+) momentary pulse. This switch must be active while the ignition is on.*

# table of zones

---

When using the diagnostic functions, use the Table of Zones to determine which input has triggered the system. It is also helpful in deciding which input to use when connecting optional sensors and switches.

Zone Number	Trigger Type	Input Description
One	Instant	Databus or H1/6 BLUE wire. Connect to optional hood/trunk pins.
Two	Multiplexed	Heavy impact detected by the on-board Doubleguard shock sensor.
Three	Two-stage, progresses from warning to full alarm	Door switch circuit. Databus.
Four	Multiplex	BLUE and GREEN wires of optional sensor plug. Inputs shorter than 0.8 seconds will trigger a Warn Away response, while inputs longer than 0.8 seconds will instantly trigger full alarm sequence.
Five	Two-stage (similar to doors)	Ignition input. H1/9 YELLOW.

*The Warn Away response does not report on the LED.*



# troubleshooting

---

## ■ **Optional starter kill does not work:**

Is the correct starter wire being interrupted? If the car starts when the optional starter kill relay is completely disconnected, the wrong starter wire has been interrupted. Is the yellow wire connected to true ignition? Make sure the yellow wire is not connected to an accessory circuit.

## ■ **Shock sensor does not trigger the alarm:**

Has the false alarm prevention circuitry been triggered? If so, you will hear five chirps when disarming. To check this, turn the ignition key on and off to clear the false alarm prevention from memory, and then retest the shock sensor. For a detailed description of false alarm prevention circuitry, refer to the owner's guide.

## ■ **Door input does not immediately trigger full alarm. Instead, first I hear chirps for three seconds:**

That is how the progressive two-stage door input works! This is a feature of this system. This is an instant trigger, remember, so that even if the door is instantly closed, the progression from chirps to constant siren will continue.

## ■ **Closing the door triggers the system, but opening the door does not:**

Have you correctly identified the type of door switch system? This often happens when the wrong door input has been used. (See the *Finding the Wires You Need, Door Pin Switch Circuit* section of this guide.)

## ■ **System will not passively arm until it is remotely armed and then disarmed:**

Are the door inputs connected? Is a BLUE wire connected to the door trigger wire in the vehicle?

## ■ **Door input does not respond with the progressive trigger, but with immediate full alarm:**

Which zone does the LED indicate? If the LED indicates that the impact sensor caused the trigger, the sensor may be detecting the door opening. Reducing the shock sensor sensitivity or relocating the control module can often solve this problem.

## ■ **The Valet switch does not work:**

Is it plugged into the correct socket? (See the *Plug-In Harnesses* section of this guide.)

Did you wait 3 seconds after pressing the Valet switch the correct number times? The alarm system must first verify the pulse count before disarming.

Check the *System Features Learn Routine* for the programmed Valet pulse count.

## ■ **Status LED does not work:**

Make sure that it is plugged in. Is the LED plugged into the correct socket? (See the *Plug-In Harnesses* section of this guide.)

# Wiring Quick Reference Guide

