



Commercial Vehicle Productivity and Security

The Guardian 6200 is a high-performance beacon designed for commercial vehicle applications that require location based services including productivity and security. It is ideally suited to installations in delivery and service fleets as well as public safety, mass transportation, utility, and off-road or construction vehicles.

Security features include vehicle theft detection and recovery as well as a means of connecting optional auxiliary sensors and panic buttons anywhere within the vehicle.



Kit Contents

- GPS Beacon device
- Combined GPS/GPRS antenna
- Wiring harness
- Mounting bracket and hardware

Tools/Supplies Required

- Wire cutters / wire strippers
- Voltmeter (multimeter)
- Soldering iron / solder
- Electrical tape
- Plastic cable ties
- Screw drivers
- Wrenches/sockets
- In-line fuse holder
- 2-Amp fuse

For additional installation information please refer to the Installation Best Practices document available through the Resource Center in your Dealer Portal.

1 Install Antennas

The Guardian 6200 comes with a combined GPS/GPRS antenna module. It is to be installed in a location where the GPS performance will be optimum. The integrated adhesive patch will allow easy attachment to a window or non-metallic panel.

Determine the best location for the GPS Antenna

- The antenna is to be installed inside the vehicle – it is not waterproof or weatherproof.
- The top side of the antenna module (identified by the peel-and-stick adhesive patch) must have a clear signal path to as much of the sky as possible.
- If the installation is not required to be covert, an ideal location is on the front windshield glass.
- For covert installations, an ideal location is under the dashboard, as high and close to the front windshield as possible (see diagrams).
- If installing in a car, the antenna can usually be mounted on the rear window or in the trunk, under the rear deck, as close to the rear window as possible.

- If there is not a suitable flat mounting surface on which to stick the integrated adhesive patch, affix the antenna module in place with a caulking type adhesive or plastic tie wraps.
- Coil and secure any loose or extra lengths of antenna cables - do not allow antenna cables to kink.



- Signals will penetrate upholstery, carpet, plastic dashboards, etc., but not metal panels or brackets
- Signals will penetrate window glass but not metallic tinted windows or painted edges of windows
- Radio antenna or defrost wires embedded in glass may degrade signals

For best performance, the adhesive side of the antenna should face the sky through the area of least signal blockage

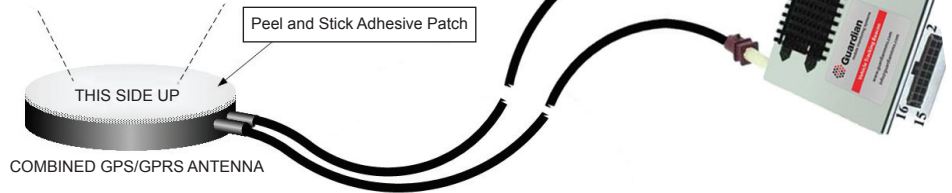

2 Beacon Installation Position

- Determine beacon installation position but do not fasten it in place until all wiring is complete.
- Determine the best location for the beacon – a strong flat surface that can be drilled to accommodate the mounting screws is ideal. Any spot where the beacon can be fastened in place with plastic cable ties is suitable.
- Under a seat is often a suitable location for beacon installation. Be sure it is not close to any heat sources or areas that experience moisture or vibration.
- Visibility of the indicator LED will be useful for testing and troubleshooting. Adequate space for wiring must be available at both ends of the beacon.

3 Connect Power & Ignition Sense

The 6200 power harness has two wire bundles each containing 4 wires. The Power Bundle contains the 12V (white), Ground (brown), and Ignition Sense (yellow) wires, plus an unused green wire. The Power Bundle is wrapped in black jacketing. The second bundle is the I/O Bundle. The I/O Bundle contains the Panic (black) and Auxiliary (white) wires, plus red and green output wires. The I/O Bundle is wrapped in grey jacketing.

All connection points and wire colors documented in this section reference the Power Bundle.

Notes:

- Connect the wiring harness to all the vehicle's connection points before attaching the harness to the beacon.
- If wiring harness wires need to be extended, use the same grade wire and solder the extension wire on, then insulate with heat shrink tubing or electrical tape.
- Ensure that no wires are routed near heat sources.

Power Connection Instructions

- Connect the brown (ground) wire to battery negative or the vehicle chassis – this wire **MUST** be connected first, before the power or ignition sense wires. Be sure the grounding screw is not painted or coated with an insulating material.
- With the vehicle's ignition turned off, use a voltmeter to assist in finding a suitable, uninterruptible 12 Volts power

connection point – directly to the vehicle's battery may be best. Connect the white (power) wire to this point through an in-line 2-Amp fuse (optional – but highly recommended).

Ignition Sense Connection

- Find a source of 12 Volts that is switched on and off with the ignition key. This connection should produce 12 Volts when the vehicle is ON and 0 Volts when the vehicle is OFF. Connect the yellow (ignition sense) wire to this point.
- Ensure that any wires in the wiring harness that are not to be connected do not come in contact with power, ground, or any other voltage. Insulate them with electrical tape.

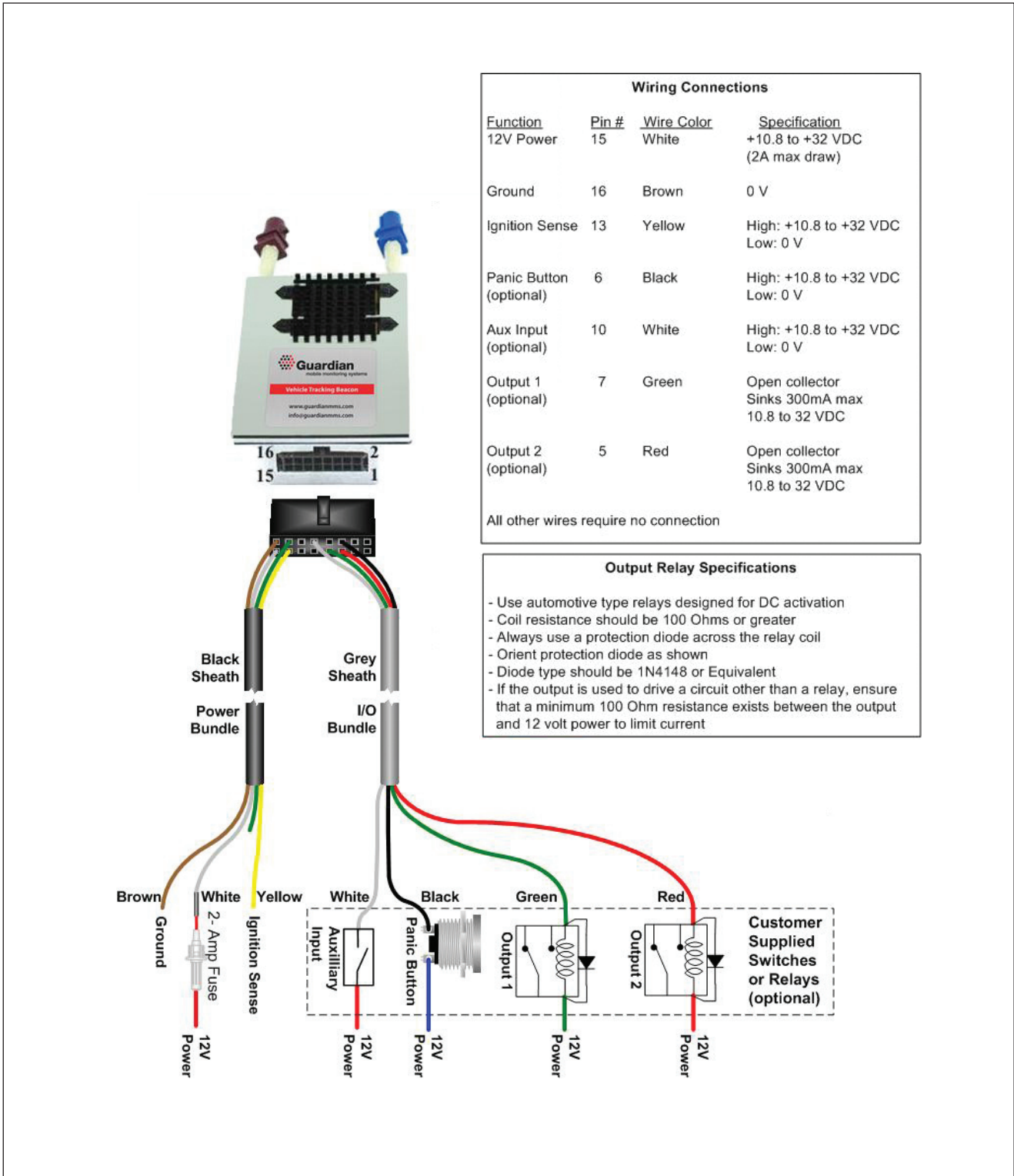

4

Optional Auxiliary Input, Panic Button, or Outputs (I/O Bundle)

All connection points and wire colors documented in this section reference the I/O Bundle.

Auxiliary Input

- The Auxiliary input can be used to detect and report a change of voltage – both low to high and high to low. Connect a switch or relay from your alarm system or any other switched device to be monitored. When closed, the switch must connect 12 Volt power to pin 10 (white wire of the I/O Bundle). When open, the switch must connect this wire to ground (0 Volts) or to nothing at all.

Panic Button

- Following the wiring diagram, connect a panic button to pin 6 (black wire of the I/O Bundle). Connect the other terminal of the button to 12V power. The Panic button must be a momentary contact switch that connects 12 Volts power to pin 6 when it is pressed.

Outputs

- Outputs can be used to remotely control vehicle functions such as door lock/unlock and ignition disable/enable.
- There are two outputs available. Each can be configured, via the web portal, to either toggle or pulse. The outputs are control signal level current sinks (the opposite of a current driver) so they must generally activate a relay in order to switch vehicle functions.
- Follow the wiring diagrams and Output Relay Specifications carefully when connecting the beacon outputs into vehicle systems.

5

Connect and Mount Beacon

- Connect the two antenna cables to the beacon using the corresponding coaxial connectors.
- Attach the wiring harness to the beacon and ensure that the retaining clip snaps in place.
- Affix the beacon securely to the vehicle using the mounting plate and screws provided. Drill mounting holes as required.
- If a suitable panel for affixing the supplied mounting plate is not available, fastening the beacon to a bracket or wire bundle with plastic cable ties is also adequate.
- Coil and secure any loose or extra length wire.

6

Test

- For the first test, the vehicle should be outdoors in an open area where GPS signals can be readily received
- Watch the indicator LED on the beacon for the first few minutes after all power and antennas have been connected. It indicates the following status:

Color/Action	Function
Orange/Steady	Searching for satellites – no fix
Orange/Flashing	GPS fix acquired
Green/Steady	GSM Connection established
Green/Flashing	GPRS Data being transferred

NOTE

It may take up to an hour, usually much less, for the wireless network and the GPS receiver to synchronize the first time the beacon is powered up.

- Ensure that the indicator LED is showing flashing green.
- Perform an end-to-end system test by locating the beacon via the user portal