



# Model PRO-9276

## Installation Manual

The selectable features can be set manually as explained below, or with the RF feature programmer. To set features using the RF programmer, follow the instructions packaged with the programmer. Factory default settings are indicated by bold text.

**Note :** The method of manual override can either be selected to operate from the valet switch or operate as custom code.

Be certain to place a check mark indicating the method used in the box located on the last page of the owner's manual.

NOTE: Keyless Entry Models with no horn output will Flash the Parking Lights instead of chirp where chirp is indicated.

Also, No data will be indicated if a feature is not available for a particular model. The unit will enter the feature but no selection will be available.

**RF Programmable Feature Bank 1 Is For Transmitter Programming See Transmitter Programming Guide.**

### RF Programmable Features Bank 2 Is Alarm Selectable Features:

Feature Selection	<u>1 Chirp</u>	<u>2 Chirps</u>	<u>3 Chirps</u>	<u>4 Chirps</u>	<u>5 Chirps</u>	<u>6 Chirps</u>
<u>1st DoorL/UL</u>	<b>1 Sec.</b>	3.5 Sec.	1 Sec L, Dbl. U/L	Dbl L, 1 Sec UL	Dbl L, Dbl UL	1 S I/350mS ul
<u>2nd Accy Lock</u>	Auto Lock On	<b>Auto Lock Off</b>				
<u>3rd Accy. UL</u>	Auto UL Dr.	Auto UL All	<b>Auto UL Off</b>			
<u>4th Headlights</u>	<b>Not Available</b>					
<u>5th Passive Locks</u>	<b>Not Available</b>					
<u>6th Pass/Act Arm</u>	<b>Not Available</b>					
<u>7th Siren/Horn</u>	<b>Not Available</b>					
<u>8th Horn Chirp</u>	10mS	<b>16mS</b>	30mS	40mS	50mS	
<u>9th O/R Method</u>	<b>Not Available</b>					
<u>10th 2 Step U/L</u>	On	<b>Off</b>				
<u>11th Chp Del Tx</u>	On	<b>Off</b>				
<u>12th Vlot Sense/Hd Wire</u>	Not Available					
<u>13th Trigger Circuits</u>	Not Available					
<u>14th L/UL Poll</u>	Not Available					
<u>15th Aux Ch 5 Sel</u>	<b>Pulse</b>	Push & Hold	10 Sec	20 Sec	Latch On/Off	Hold 3/S For O/P
<u>16th Aux Ch 6 Sel</u>	<b>Pulse</b>	Push & Hold	10 Sec	20 Sec	Latch On/Off	Hold 3/S For O/P
<u>17th Aux Ch 7 Sel</u>	<b>Pulse</b>	Push & Hold	10 Sec	20 Sec	Latch On/Off	Hold 3/S For O/P
<u>18th Trigger Delay</u>	<b>Not Available</b>					

### When using the RF programmer, enter the program mode as follows:

Turn the ignition on.

Press and release valet switch 3 times;

turn ignition off then on.

Press and hold valet switch for 5 seconds.

Siren and or lights chirp/flash 2 times indicating access to RF feature program mode.

**To program these selectable features;**

	<u>Action</u>	<u>System Response</u>
	Turn ignition on	No response
	Press and release the valet switch 3 times	1 Chirp - LED 1 flash
	Within 3 seconds, turn ignition Off Then On	Short chirp, then long chirp
	This Action Accesses Feature Bank 2 Alarm	Selectable Features
<u>First</u>	Press and release the valet switch 1 time	1 chirp = 1 second door lock & unlock
	Press transmitter Lock button to change	2 chirps = 3.5 second door lock & Unlock
	Press transmitter Lock button to change	3 chirps = 1 sec. lock, dbl 1 sec. unlock
	Press transmitter Lock button to change	4 chirps = dbl 1 sec lock, 1 sec unlock
	Press transmitter Lock button to change	5 chirps = dbl 1 sec lock, dbl 1 sec unlock
	Press transmitter Lock button to change	6 chirps = 350mS unlock. 1 sec lock
	<b>or</b>	
<u>Second</u>	Press and release the valet switch	2 chirps = auto locks off
	Press transmitter Lock button to change	1 chirp = auto locks on
	<b>or</b>	
<u>Third</u>	Press and release the valet switch	3 chirps = auto unlock off
	Press transmitter Lock button to change	1 chirp = auto unlock drivers door only
	Press transmitter Lock button to change	2 chirps = auto unlock all doors
	<b>or</b>	
<u>Fourth</u>	Press and release the valet switch	Non Functional On This Unit
	<b>or</b>	
<u>Fifth</u>	Press and release the valet switch	Non Functional On This Unit
	<b>or</b>	
<u>Sixth</u>	Press and release the valet switch	Non Functional On This Unit
	<b>or</b>	
<u>Seventh</u>	Press and release the valet switch	Non Functional On This Unit
	<b>or</b>	
<u>Eighth</u>	Press and release the valet switch	2 chirps = horn chirp output 16mS
	Press transmitter Lock button to change	3 chirps = horn chirp output 30mS
	Press transmitter Lock button to change	4 chirps = horn chirp output 40mS
	Press transmitter Lock button to change	5 chirps = horn chirp output 50mS
	Press transmitter Lock button to change	1 chirp = horn chirp output 10 mS
	<b>or</b>	
<u>Ninth</u>	Press and release the valet switch	Non Functional On This Unit
	<b>or</b>	
<u>Tenth</u>	Press and release the valet switch	2 chirps = 2 step unlock off
	Press transmitter Lock button to change	1 chirp = 2 step unlock on
	<b>or</b>	
<u>Eleventh</u> inactive	Press and release the valet switch	2 chirps = chirp delete from transmitter
	Press transmitter Lock button to change	1 chirp = chirp delete from transmitter active
	<b>or</b>	
<u>Twelfth</u>	Press and release the valet switch	Non Functional On This Unit
	<b>or</b>	
<u>Thirteenth</u>	Press and release the valet switch	Non Functional On This Unit
	<b>or</b>	
<u>Fourteenth</u>	Press and release the valet switch	Non Functional On This Unit
	<b>or</b>	
<u>Fifteenth</u>	Press and release the valet switch	1 chirp = ch 5 pulsed output
	Press transmitter Lock button to change	2 chirps = ch 5 output as long as button held
	Press transmitter Lock button to change	3 chirps = ch 5-10 second output
	Press transmitter Lock button to change	4 chirps = ch 5-20 second output
	Press transmitter Lock button to change	5 chirps =ch 5 latch on/latch off output
	Press transmitter Lock button to change	5 chirps = ch 6 hold 3 sec for pulsed output
	<b>or</b>	
<u>Sixteenth</u>	Press and release the valet switch	1 chirp = ch 6 pulsed output
	Press transmitter Lock button to change	2 chirps = ch 6 output as long as button held
	Press transmitter Lock button to change	3 chirps = ch 6-10 second output
	Press transmitter Lock button to change	4 chirps = ch 6-20 second output
	Press transmitter Lock button to change	5 chirps =ch 6 latch on/latch off output
	Press transmitter Lock button to change	5 chirps = ch 6 hold 3 sec for pulsed output
	<b>or</b>	
<u>Seventeenth</u>	Press and release the valet switch	1 chirp = ch 7 pulsed output
	Press transmitter Lock button to change	2 chirps = ch 7 output as long as button held
	Press transmitter Lock button to change	3 chirps = ch 7-10 second output
	Press transmitter Lock button to change	4 chirps = ch 7-20 second output
	Press transmitter Lock button to change	5 chirps =ch 7 latch on/latch off output
	Press transmitter Lock button to change	5 chirps = ch 7 hold 3 sec for pulsed output
	<b>or</b>	
<u>Eighteenth</u>	Press and release the valet switch	Non Functional On This Unit
	<b>or</b>	
	Press and release the valet switch or turn the ignition off to:	Exit Programming Mode
	<b>or</b>	
	<b>Turn ignition switch off then on to advance to feature Bank 3:</b>	

To exit program mode, turn ignition off, or press and release valet switch.

**RF Programmable Features Bank 3 Is Remote Start Selectable Features:**

<u>Feature Selection</u>	<u>1 Chirp</u>	<u>2 Chirps</u>	<u>3 Chirps</u>	<u>4 Chirps</u>	<u>5 Chirps</u>	<u>6 Chirps</u>
1st Defrost Output	<b>Pulsed</b>	10 Mins				
2nd RF Start Chirp	Off	On	<b>On &amp; Car Finder</b>			
3rd Run Time	5 Mins	<b>10 Mins</b>	15 Mins	20 Mins		
4th Parking Lights	<b>On Steady</b>	Flashing				
5th Input Check	Voltage	<b>Tach</b>	DBI Tach			
6th Voltage Level	<b>&gt;0.5V B4 Start</b>	< 0.5V B4 Start				
7th Ign. 2 Select	Off During Crank	<b>On During Crank</b>	Same As Accy.			
8th Ign. 3 Select	Off During Crank	<b>On During Crank</b>	Same As Accy	Same As Starter		
9th Diagnostics	<b>Off</b>	On				
10th Crank Time	0.8 Sec	<b>1.0 Sec</b>	1.5 Sec	2.0 Sec		
11th Gas/Diesel	<b>Gas</b>	Diesel 10	Diesel 15	Diesel 20		
12th Transponder O/P	<b>While R/S On</b>	During Start	Until Ign. Off			
13th Temp Start	Not Available					
14th Crank Averaging	<b>Averaging</b>	Preset Time				
<b>Note:</b> When averaging, the engine must be started 4 times with the key to be effective.						
15th R/S Shock	<b>Not Available</b>					
16th Turbo Select	<b>Off</b>	3 Mins	5 Mins	10 Mins		
17th Black/Blue (Aux O/P)	<b>Single Pulse</b>	As Feat #1 Bank 2				

**When using the RF programmer, enter the program mode as follows:**

Turn the ignition on.

Press and release valet switch 3 times;

turn ignition off then on.

Press and hold valet switch for 5 seconds.

Siren chirps 2 times indicating access to RF feature program mode.

To exit program mode, turn ignition off, or press and release valet switch.

<u>Action</u>	<u>System Response</u>	
	Turn ignition on Press and release the valet switch 3 times Within 3 seconds, turn ignition Off, On, Off, On This Action Accesses Feature Bank 3 Remote Start Selectable Features	No response 1 Chirp - LED 1 flash Short chirp, then 2 long chirps
<u>First</u>	Press the valet switch one time Press transmitter Lock button to change or	1 chirp = defrost output pulsed 2 chirps = defrost output 10 Mins
<u>Second</u>	Press and release the valet switch Press transmitter Lock button to change or	2 chirps = RF start chirp on 1 chirp = RF start chirp off
<u>Third</u>	Press and release the valet switch Press transmitter Lock button to change Press transmitter Lock button to change Press transmitter Lock button to change or	2 chirps = run time set for 10 mins 3 chirps = run time set fro 15 mins 4 chirps = run time set for 20 mins 1 chirp = run time set for 5 mins
<u>Fourth</u>	Press and release the valet switch Press transmitter Lock button to change or	1 chirp = parking lights on steady w/RS active 2 chirps = parking lights flashing w/RS active
<u>Fifth</u>	Press and release the valet switch Press transmitter Lock button to change or	2 chirps = tachometer input checking 1 chirp = voltage sense input checking
<u>Sixth</u>	Press and release the valet switch Press transmitter Lock button to change or	1 chirp = greater than 0.5 V check before start 2 chirps = less than 0.5 V check before start
<u>Seventh</u>	Press and release the valet switch Press transmitter Lock button to change Press transmitter Lock button to change or	2 chirps = ign 2 on during crank 3 chirps = ign 2 same as accessory 1 chirp = ign 2 off during crank
<u>Eighth</u>	Press and release the valet switch Press transmitter Lock button to change Press transmitter Lock button to change Press transmitter Lock button to change or	2 chirps = ign 3 on during crank 3 chirps = ign 3 same as accessory 4 chirps = ign 3 same as starter 1 chirp = ign 3 off during crank
<u>Ninth</u>	Press and release the valet switch Press transmitter Lock button to change or	1 chirp = diagnostics off 2 chirps = diagnostics on
<u>Tenth</u>	Press and release the valet switch Press transmitter Lock button to change Press transmitter Lock button to change Press transmitter Lock button to change or	2 chirps = crank time 1.0 sec 3 chirps = crank time 1.5 sec 4 chirps = crank time 2.0 sec 1 chirp = crank time 0.8 sec
<u>Eleventh</u>	Press and release the valet switch Press transmitter Lock button to change Press transmitter Lock button to change Press transmitter Lock button to change or	1 chirp = unit set for gasoline engine 2 chirps = unit set for diesel engine 10 sec delay 3 chirps = unit set for diesel engine 15 sec delay 4 chirps = unit set for diesel engine 20 sec delay
<u>Twelfth</u>	Press and release the valet switch Press transmitter Lock button to change Press transmitter Lock button to change or	1 chirp = transponder output while R/S active 2 chirps = transponder output during start only 3 chirps = transponder output until ignition turned off
<u>Thirteenth</u>	Press and release the valet switch or	Non Functional On This Unit
<u>Fourteenth</u>	Press and release the valet switch Press transmitter Lock button to change	1 chirp = crank averaging w/voltage input checking 2 chirps = preset crank time w/voltage input check
<u>Fifteenth</u>	or	Non Functional On This Unit
<u>Sixteenth</u>	Press and release the valet switch Press transmitter Lock button to change Press transmitter Lock button to change Press transmitter Lock button to change or	1 chirp = turbo timer off 2 chirps = turbo timer 3 mins 3 chirps = turbo timer 5 mins 4 chirps = turbo timer 10 mins
<u>Seventeenth</u>	Press and release the valet switch Press transmitter Lock button to change Press and release the valet switch or turn the ignition off to:	1 chirp = aux o/p Black/Blue single pulse 2 chirps = aux o/p Black/Blue as alarm feature #1  Exit Programming Mode

**Note :** Once you enter the feature programming mode, do not allow more than 15 seconds to pass between steps or the programming will be terminated.

This Remote Start System is designed for use with Automatic Transmission Vehicles Only! The unit provides wait to start input for glow plug pre-heat which will be used for all diesel applications. If this wire is not connected, then the unit will remain in the Gasoline mode setting, which will crank the car when the RF signal is received with no delay. Regardless of the vehicle, Gasoline or Diesel, for every installation, the vehicle

---

**MUST HAVE a Tach Signal Input, and an Automatic Transmission.**

---

**INSTALLATION OF THE MAJOR COMPONENTS:**

**CONTROL MODULE:**

Select a mounting location inside the passenger compartment (up behind the dashboard). The mounting location selected must be within 24" of the ignition switch wiring harness to allow connection of the 6 pin main wiring harness.

Be certain that the chosen location will not interfere with proper operation of the vehicle. Avoid mounting the module to or routing the wiring around the steering shaft/column, as the module or wiring may wrap around or block the steering wheel preventing proper control of the vehicle. Secure the module in the chosen location using cable ties or screws as necessary.

**NOTE:** Do Not Mount The Module In The Engine Compartment, as it is not waterproof.

**HOOD PIN SWITCH:**

The hood pin switch included in this package is required for the safety shut down of the remote start unit. If the vehicle is being worked on, this hood switch prevents the remote start activation even if the RF command to start is issued. This hood pin switch **MUST** be installed in all applications. Failure to install the hood pin switch may result in personal injury or property damage. Mount the hood pin switch in an area under the hood that is away from water drain paths. If necessary, the included brackets may be used to move the hood pin switch away from rain gutters or allow mounting to the firewall behind the hood seal. In either case the hood pin switch must be set up to allow the hood to depress the switch at least 1/4" when the hood is closed and fully extended when the hood is opened. For direct mounting, a 1/4" hole must be drilled. Carefully check behind the chosen location to insure the drill will not penetrate any existing factory wiring or fluid lines. Drill a 1/4" hole in the desired location and thread the hood pin switch into it using a 7/16" nut driver or deep well socket. If using the mounting bracket, first secure the bracket to the desired location and secure the hood pin switch in the pre-threaded mounting bracket hole.

**PUSHBUTTON LED SWITCH**

Select a mounting location known and accessible to the operator of the vehicle. A dash knockout plug or front dash panel is desirable as the now Pushbutton LED assembly needs the LED to be visible from the outside of the vehicle and will be used for valet modes, programming features, programming transmitters, and for overriding the remote start unit when the vehicle is being serviced. Inspect behind the chosen location to insure that adequate clearance is allowed for the body of the switch, and also that the drill will not penetrate any existing factory wiring or fluid lines. Drill a 5/16" or 8mm hole in the desired location and mount the switch by passing the connectors, one at a time, through the panel from the front side and pressing on the bezel until the switch is fully seated.

This system is to be used in vehicles with **AUTOMATIC TRANSMISSIONS** only! Although this combination Keyless Entry/Remote Start unit is a sophisticated system with many advanced features, **IT MUST NOT** be installed into a vehicle with a manually operated transmission. Doing so may result in serious personal injury and property damage.

**THE RECEIVER/ANTENNA ASSEMBLY:**

The Receiver Antenna Assembly provided with this unit allows routing from below the dashboard for maximum operating range. Choose a location above the belt line (dashboard) of the vehicle for best reception. Special considerations must be made for windshield glass as some newer vehicles utilize a metallic shielded window glass that will inhibit or restrict RF reception. In these vehicles, route the antenna toward a rear window location for best reception. Secure the antenna with double stick tape provided. After securing the antenna with tape, we advise also securing a section of the antenna cable to a fixed support. This will prevent the antenna from dropping down in case the double stick tape is exposed to extreme heat, which may loosen its gummed surface. Route the connector toward the control module using caution not to pinch the cable as this will cause poor or no RF reception to the control module.

**IMPORTANT!**

DO NOT PLUG THE SIX PIN MAIN POWER HARNESS OR THE MULTI PIN INPUT / OUTPUT HARNESS INTO THE CONTROL MODULE UNTIL ALL CONNECTIONS TO THE VEHICLE HAVE BEEN MADE. AFTER SELECTING YOUR TARGET WIRES AS DEFINED BELOW, DISCONNECT THE NEGATIVE BATTERY CABLE FROM THE VEHICLE BATTERY PRIOR TO MAKING ANY CONNECTIONS.

**WIRING THE 6 PIN MAIN POWER HARNESS:**

**Note:** Do not remove the fuse holders from this wire harness. Fuses must be used and located as close as possible to the power source for adequate protection of the vehicle.

**Fused RED w/ WHITE TRACE WIRE:** + 12 volt Battery 1 Source

Locate the vehicle battery wire(s) at the ignition switch. Verification: These wires will register voltage in all positions of the ignition switch. Connect the Red w/White wire to the vehicle's battery wire. This wire provides power for the control circuit as well as the ignition 1 and ignition 2 relays.

**Fused RED WIRE:** + 12 Volt Battery 2 Source

Locate the vehicle battery wire(s) at the ignition switch. Verification: These wires will register voltage in all positions of the ignition switch. Connect the Red wire to the vehicle's battery wire. This wire provides power for the start relay and the accessory relay.

**IMPORTANT!**

IT IS THE RESPONSIBILITY OF THE INSTALLING TECHNICIAN TO DETERMINE THE LOAD FACTOR OF THE VEHICLES ELECTRICAL CIRCUITS WHEN THE VEHICLE IS RUNNING AND TO ADEQUATELY FUSE THE TWO POWER WIRES BASED ON THAT LOAD. IF THE VEHICLE, RUNNING UNDER LOAD WITH THE AIR CONDITIONER, HEATER BLOWER MOTOR, AND ACCESSORIES EXCEEDS 24 AMPS CONTINUOUS, WE RECOMMEND THAT TWO FUSES BE USED IN COMBINATION ON EACH POWER WIRE AS SHOWN BELOW. FOR ADDITIONAL INFORMATION SEE TECH UPDATE ISSUED 9/30/96.

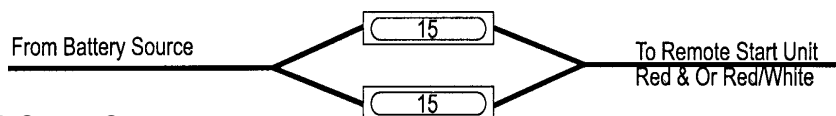

**YELLOW WIRE:** Starter Output

**Careful consideration for the connection of this wire must be made to prevent the vehicle from starting while in gear. Understanding the difference between a mechanical and an electrical Neutral Start Switch will allow you to properly identify the circuit and select the correct installation method. In addition you will realize why the connection of the safety wire is required for all mechanical switch configurations.**

Failure to make this connection properly can result in personal injury and property damage. In all installations it is the responsibility of the installing technician to test the remote start unit and assure that the vehicle cannot start via RF control in any gear selection other than park or neutral.

In both mechanical and electrical neutral start switch configurations, the connection of the Yellow wire will be made to the low current start solenoid wire of the ignition switch harness. This wire will have +12 volts when the ignition switch is turned to the start (crank) position only. This wire will have 0 volts in all other ignition switch positions.

**NOTE:** This wire must be connected to the vehicle side of the starter cut relay (when used). For the electrical neutral switch configuration, this connection must be made between the starter inhibit relay, (when used) and the neutral safety switch as shown in the following diagram.

Failure to connect this wire to the ignition switch side of the neutral safety switch can result in personal injury and property damage.

**SEE NEUTRAL START SAFETY TEST FOR FURTHER DETAILS.**

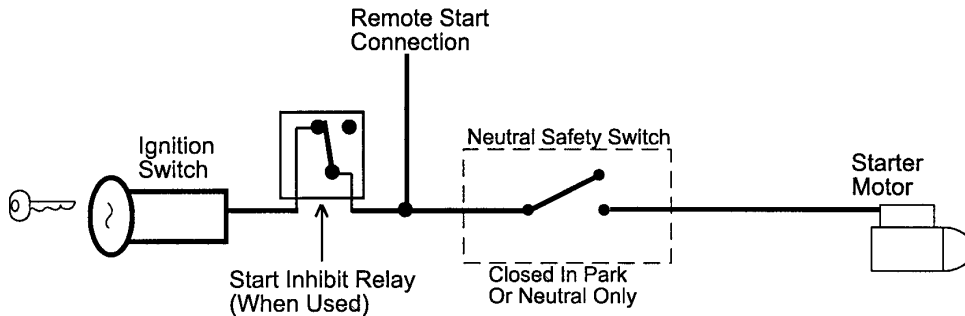

**BLUE WIRE:** Ignition 1 Output

Connect this wire to the ignition 1 wire from the ignition switch. This wire will show +12 volts when the ignition key is turned to the "ON" or "RUN" and the "START" or CRANK" positions and will have 0 volts when the key is turned to the "OFF" and "ACCESSORY" positions.

For Diesel Applications, this wire must be connected to the ignition circuit that powers the glow plugs if the vehicle requires glow plug pre-heating.

**GREEN WIRE:** Ignition 2 Output

Connect this wire to the ignition 2 wire from the ignition switch. This wire will show + 12 volts when the ignition key is turned to the "ON" or "RUN" position and in some cases the "START" or CRANK" position. This wire will show 0 volts when the key is turned to the "OFF" and "ACCESSORY" positions.

**NOTE:** See programming information concerning this wire to allow output during the "START" mode.

**VIOLET WIRE:** Accessory Output

Connect this wire to the Accessory wire from the ignition switch. This wire will show + 12 volts when the ignition switch is turned to the "ACCESSORY" or "ON" and "RUN" positions and will show 0 volts when the key is turned to the "OFF" and "START" or "CRANK" positions.

**WIRING THE 6 PIN MAIN POWER HARNESS**

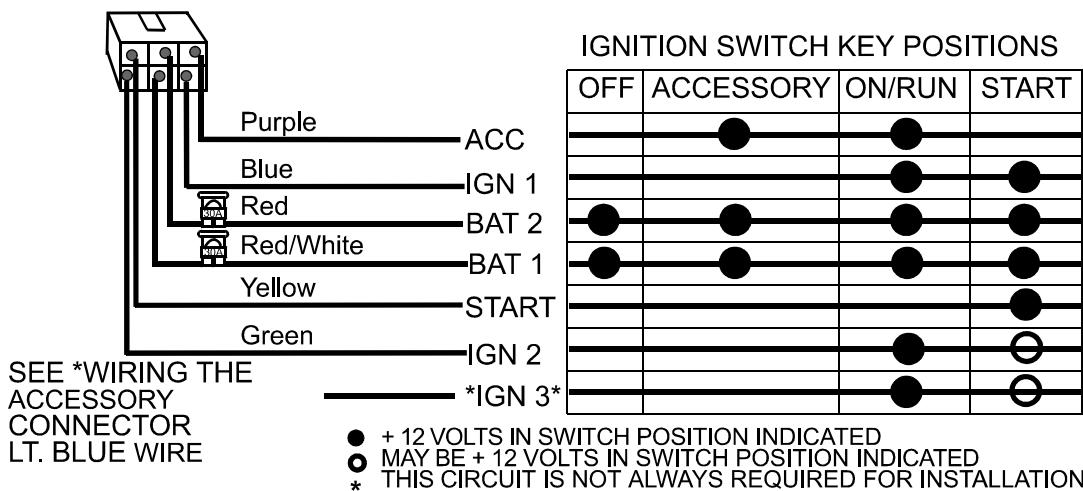

### **WIRING THE 4 PIN ALTERNATE IGNITION HARNESS**

**ORANGE/BLACK Wire:** Parking Brake Input

This wire is used only when the turbo timer mode, Bank 3, feature # 16 is selected ON. This input insures that the vehicle parking brake is applied whenever the vehicle is set up for and the turbo timer circuit is used. This input must switch to ground when the vehicle's parking brake is applied. Connect the Orange/Black wire to the negative output of the vehicle's parking brake switch.

**RED/BLACK Wire:** + 12 Volts Input

Note: The Red/Black and Pink are dry contacts and may be used for negative switching when necessary. Connecting the Red/Black to chassis ground will result in Pink being ground when the R/S is activated.

This input is to be connected to a separate, (Other than the wire Red or Red/White is connected to), constant on + 12 volt source which will supply + 12 volt power to the additional ignition output, (Pink), wire. Connect this wire to a separate + 12 Volt source.

**PINK Wire:** Additional Ignition Output

This wire can be used as an additional + 12 Volt ignition output supplied by the Red/Black wire. This output can be selected to be on or off during the start cycle. (See feature bank 3 selection # 8) Connect this wire to the third ignition circuit in the vehicle and set the selectable feature # 8 of Bank 3 according to the way in which the vehicle's ignition switch operates.

**Note: Do not remove the fuse holders from this wire harness. Fuses must be used and located as close as possible to the power source for adequate protection of the vehicle.**

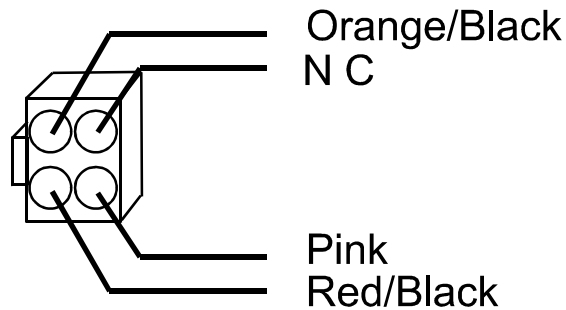



### WIRING CONNECTIONS: 12 Pin Input / Output Harness

**Black Wire:** Chassis Ground Source. Connect the Black wire to a known vehicle ground source or to a solid clean metal part of the chassis. Be certain to remove any paint or grease and secure this wire with a self-tapping screw and ring terminal.

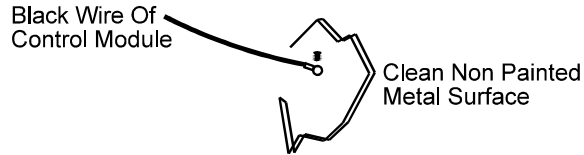

### GRAY WIRE: Negative Inhibit Input 1

Connect the GRAY wire to the previously mounted hood pin switch provided. This wire will be routed through the firewall into the engine compartment. It is necessary to use an existing grommet when passing wires through the firewall to prevent short circuiting. This is an important safety feature of the System, failure to use this feature can result in serious injury. Route the wire to the pin switch and connect it using the bullet connector provided.

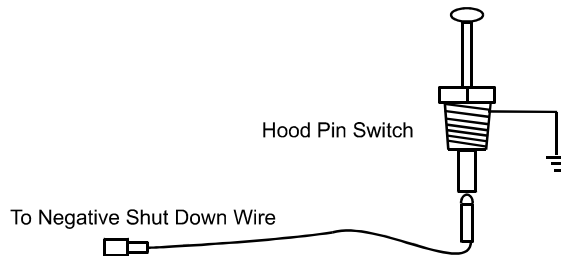

### GRAY w/BLACK TRACER WIRE: Negative Inhibit Input 2

Any time the gray w/ black tracer wire is grounded, the Remote Starter will stop operating, even if the signal is received from the transmitter.

If the brake light switch in the vehicle switches ground to the brake light circuit, connect the Gray w/ Black trace wire to the output of the brake light switch. If the brake light switch in the vehicle switches +12 Volts, do not use the Gray w/ Black wire; see Brown w/ Black tracer wire.

### BROWN WIRE: Positive Inhibit Input 1

Any time + 12 Volts is applied to the Brown wire, the Remote Starter will stop operating, even if the signal is received from the transmitter.

If the vehicle has a factory installed hood pin switch and that switch provides + 12 Volts to an under hood light, the Brown wire can be connected to the existing pin switch.

### BROWN w/ BLACK Tracer Wire: Positive Inhibit Input 2

Any time + 12 Volts is applied to the Brown w/ Black tracer wire, the Remote Starter will stop operating, even if the signal is received from the transmitter. If the brake light switch in the vehicle switches + 12 Volts to the brake light circuit, connect the Brown w/ Black trace wire to the output of the brake light switch. If the brake light switch in the vehicle switches ground, do not use the Brown w/ Black wire; see Gray w/ Black tracer wire.

### Brake Switch Positive Shutdown Detail

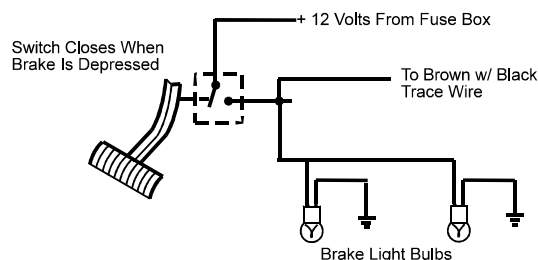

**YELLOW w/ BLACK Tracer Wire: + 12 Volt Alarm By - Pass Output**

**NOTE:** You must disconnect the ignition input of the alarm from any other wire that it is presently connected to in the vehicle.

This wire provides a + 12 Volt output when the ignition key is turned to the "ON" position, and 0 Volts when the ignition key is "OFF" and when the vehicle is running under the control of the remote starter.

This wire should be connected to the ignition input of the alarm system.

The Yellow w/ Black wire output will allow you to remote start the vehicle while leaving the alarm armed, and to lock/unlock the doors while running under control of the remote start unit.

**(2) WHITE Wires: Parking Light Flasher**

These wires are the COMMON and NORMALLY OPEN contacts of the on-board parking lamp relay.

If the vehicle's parking lights are a +12 volt switched system, connect (1) of the White wires to a fused (15A max.) +12 volt battery source, and connect the second White wire to the vehicle's parking light wire.

If the vehicle's parking lights are a chassis ground switched system, connect (1) of the White wires to a chassis ground source, and connect the second White wire to the vehicle's parking light wire.

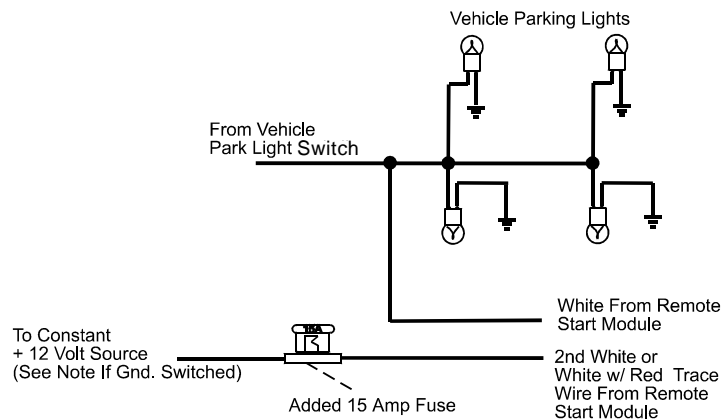

**LIGHT BLUE Wire: Ignition 3 / Shock Disable Output**

This wire provides a 300mA ground output that becomes active 3 seconds before the Remote Start Unit initializes, and remains grounded while running plus an additional 4 seconds after the Remote Start Unit turns off. In all of the applications described below, a relay will be required. The Light Blue wire can be used to accommodate the following situations:

**A. Shock Sensor By Pass:**

If there is Shock Sensor used with an alarm system and it is not shunted during the Remote Start activation period, then vibration from the running vehicle can cause the alarm to trigger. In this case, connect the Light Blue Wire to terminal #86 of a external relay. Connect terminal #85 of the relay to a fused + 12 volt battery source. Cut the shock sensor trigger wire and connect one end of the cut wire to terminal #30 and the other end of the cut wire to terminal #87a. Just before the Remote Start unit is activated, the relay contacts will open, preventing the shock sensor's operation until the Remote Start unit shuts off.

**B. Ignition 3 Output:**

Some newer vehicles use a third ignition wire, which is required to start and keep the vehicle's engine running. If this is the case, connect the Light Blue wire to terminal #86 of an external relay. Connect terminal #30 & #85 to a fused + 12 volt battery source rated for a minimum of 25 Amp. Connect terminal #87 to the third ignition wire in the vehicle.

### C. GM VATS Key Override:

If the vehicle has the General Motors VATS system installed, you will need to bypass the system while the vehicle is operating under the control of the Remote Start Unit. To Do This;

1. Measure the resistance of the resistor pellet on the ignition key then select a resistor within 5% of the key's value from the resistor pack supplied.
2. Locate the pair of VATS wires in the vehicle, usually a pair of thin gauge wires running from the ignition switch to the VATS control module.

**NOTE:** These wires are typically White w/ Black trace and Violet w/ Yellow trace, however in later model Cadillacs, they are run through an orange sleeve, and are either both Black, both Yellow, or both White wires. Consult the factory service manual for additional information.

3. Connect the Light Blue Wire from the Remote Start Unit to terminal #86 of an external relay. Connect terminal #85 of the relay to a fused + 12 volt battery source.
4. Cut (#1) wire (as shown), and connect the ignition switch side of the cut wire to terminal #87a of the relay. Connect the other side of the (#1) wire to terminal #30.
5. Connect the previously selected resistor from terminal #87 to the second (#2) wire (as shown).

**NOTE:** The above information and following diagram is for the GM VATS system only. For GM PASS LOCK System you will require the Audiovox AS-PASS II Module.

### General Motors VATS By-Pass Diagram

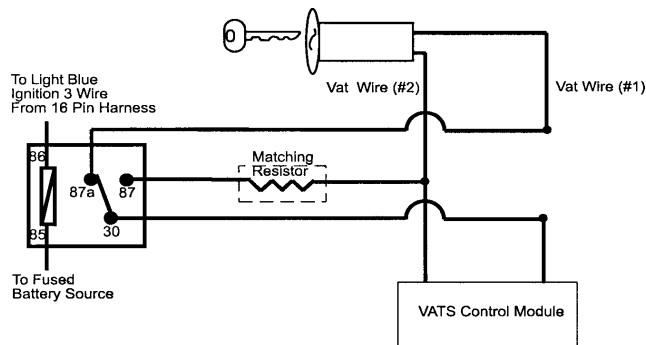

### Tachometer Input Wiring Detail

#### GREEN/ORANGE Wire: Tach Sensor Input

This wire will continually monitor the engine tach rate while the unit is under power of the Remote Start module. This wire will be routed to the vehicle ECM tach input or through the firewall into the engine compartment and connect to the negative side of the ignition coil. This Remote Start unit learns the tach rate of the vehicle and in most cases will operate properly from one multi coil pack regardless of the number of cylinders. If the vehicle has a single coil unit for each cylinder, it may be necessary to connect this wire to more than one cylinder for proper tach reference. See multi coil wiring detail shown later in this manual for additional information.

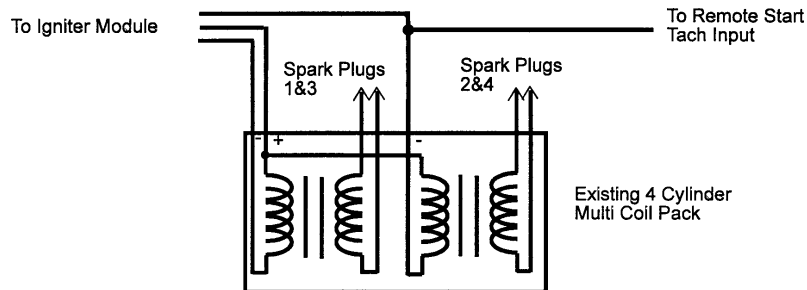

**Green/Yellow Wire: Diesel Wait To Start Input**

The Green/Yellow wire will connect to a diesel vehicles glow plug wire. When the unit receives a start command, this wire must go to + 12 then to ground to allow the crank sequence to begin. When ignition #1 is activated by the remote start unit, the glow plug circuit gets energized, (+ 12 volts), when the glow plug circuit of the vehicle drops the + 12 volts, which effectively grounds the wait to start input, then 500mS later the starter will engage. This wire can also be connected to the Glow Plug Bulb wire in the vehicle if this bulb wire gets + 12 volts when the ignition comes on and drops low when the glow plug circuits temperature is reached. Be sure to fuse the wire with a 1 Amp Fuse when connecting to a high current circuit such as a factory glow plug wire. The fuse should be installed as close to the high current wire as possible. If you are installing this unit in a Gasoline vehicle, this wire is not used.

**NOTE:** If the Glow Plug sense wire, Green/Yellow is connected, this wire will have priority over the setting of feature Bank 3 Feature #11.

**WIRING THE 4 PIN AUXILIARY OUTPUT HARNESS**

The auxiliary 4 pin connector provides low current outputs to control various functions in the vehicle during different stages of the Remote Start unit's operation. Understanding these outputs and the time in which they occur will allow you to determine if they are needed for the particular vehicle you are working on as well as how to use them.

**Black w Blue Trace Wire: Pulsed Ground Output Before Start**

The Black w/ Blue Trace wire will provide a 1 second 300 mA pulsed ground output 1.5 second before the remote start unit activates as well as when the transmitter is used to disarm the system. Typical use for this output would be to disarm a factory theft deterrent system to prevent false triggering of the factory alarm when the remote start unit engages or when the transmitter is used to unlock the doors.

**Black w/ Light Green Trace Wire: Pulsed Ground Output After Start**

The Black w/ Light Green Trace wire will provide a 1 second 300mA pulsed ground output after the vehicle is started under control of the remote start unit. Typically this wire will be used to re-lock the vehicle doors if the doors unlock automatically when the factory anti-theft system is disarmed.

**Black w/ Red Trace Wire: Pulsed Ground Output After Shutdown**

The Black w/ Red Trace wire will provide a 1 second 300 mA pulsed ground output after the remote start unit shuts down. This output will occur regardless of whether the circuit times out or is manually terminated. Typically this output will be used to re-lock the vehicle doors if the doors unlock automatically when the ignition circuit transitions to off.

**Black w/ Yellow Trace Wire: Ground Output During Start (Crank)**

The Black w/ Yellow Trace wire will provide a 300 mA ground output while the starter output of the remote start unit is active. This output can be used to activate the Crank Low/Bulb Test wire found in some GM vehicles. This wire is also referred to as the ECM wake up wire in some Chrysler vehicles.

**NOTE:** The outputs above are low current outputs and must be used with a relay if the circuit's requirement is more than 300 mA.

**Push-Button LED Programming Switch Assembly: (2 Pin Blue & 2 Pin White Connectors)**

Route the gray and black wires in the 2 pin connector and the red and blue in the two pin connector from the previously installed push-button LED programming switch assembly to the control module and plug these into the mating blue and white connectors on the side of the module.

**2 Pin Transponder Control Output: (Yellow Connector)**

This output is intended to allow the control of a transponder bypass interface module or transponder bypass relay. The system also allows software selections to control the way in which this output operates, see remote start feature # 10 for setting this output.

When the unit is selected for output during the start sequence, this output will be active at the same time Ign. 3 becomes active, and will remain active until the vehicle has started. This will be used for one time read transponder circuits.

When the unit is selected for transponder on, this output will become active at the same time ign. 3 becomes active, and will remain active all the time the unit is operational under the control of the remote start. When the unit is selected for continuous and the vehicle is started via the Remote Start, this output will become active at the same time ign. 3 becomes active and will remain active until the ignition in the vehicle goes low. This will allow the unit to be used for continuous read transponders circuits.

### 5 Pin Accessory Output Harness

#### Dark Blue Wire : Delayed 300 mA Pulsed Output/Channel 3

The dark blue wire pulses to ground via an independent RF channel from the keychain transmitter. This is a transistorized, low current output, and should only be used to drive an external relay coil.

This output is activated by the same transmitter button that is used to activate the remote start function. Press and hold the trunk/key button to activate this trunk release output, or press and release the trunk/key button two times within 2 seconds to activate the remote starter.

**WARNING:** Connecting the dark blue wire to the high current switched output of the trunk release circuits and some remote start trigger inputs, will damage the control module.

Connect the dark blue wire to terminal 86 of the AS-9256 relay (or equivalent 30 A automotive relay), connect terminal 85 to a fused +12 volt source and wire the remaining relay contacts to perform the selected function desired.

#### Channel 3 Relay Wiring Detail

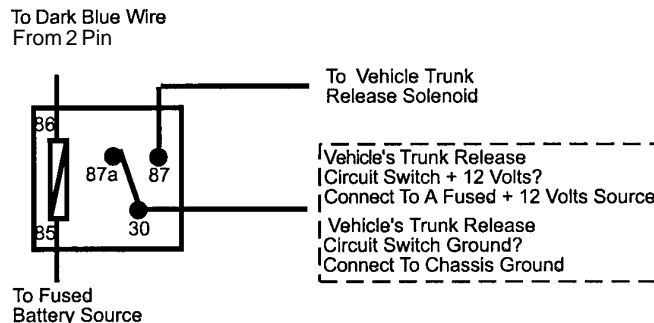

#### Green w/ Black Trace Wire: 300mA Latched Channel 4 Output

The Green w/ Black Trace wire supplies a 300 mA switched output whenever channel four of the receiver is accessed. Pressing the pre-programmed transmitter button(s) will access channel four and will remain active, for up to 20 seconds, as long as the transmitter button(s) is held. This is a low current output and must be connected to a relay to supply power to the device you intend to control. Connect Green w/ Black Trace wire to terminal #86 of a VF45F11 P&B relay or equivalent. Connect terminal #85 of the relay to a fused + 12 volt source. Connect the common, normally open, and normally closed contacts of the relay to perform the selected function of the channel 4 output.

**NOTE:** This wire also can be used for defrost activation as dictated by the setting of feature # 1 of Bank 3. Anytime the vehicle is running under control of the Remote Start and Channel 4 is activated, then dependent on the selection of this feature, Green/Black will be activated as a pulse for 1 second, or for 10 minutes. Note this wire will not operate when the vehicle is running under the power of the ignition key, only while under the control of the remote start or if not used for defrost then an output will occur as indicated above.

**WARNING ! Connecting the Dark Green w/Black trace wire to any high current switched output (300mA max.) will damage the control module.**

#### Lt Blue/Green Wire : DELAYED 300 mA PULSED OUTPUT / CHANNEL 5

The light blue/green wire pulses to ground via an independent RF channel from the keychain transmitter. This is a transistorized, low current output, and should only be used to drive an external relay coil.

**WARNING:** Connecting the light blue/green to the high current switched output of trunk release circuits, some remote start trigger inputs, will damage the control module.

Connect the light blue/green to terminal 86 of the AS - 9256 relay (or equivalent 30 A automotive relay) and wire the remaining relay contacts to perform the selected function of channel 5.

#### Lt Blue/Black Wire : DELAYED 300 mA PULSED OUTPUT / CHANNEL 6

The light blue/green wire pulses to ground via an independent RF channel from the keychain transmitter. This is a transistorized, low current output, and should only be used to drive an external relay coil.

**WARNING:** Connecting the light blue/black to the high current circuits, will damage the control module. Connect the light blue/black to terminal 86 of the AS - 9256 relay (or equivalent 30 A automotive relay) and wire the remaining relay contacts to perform the selected function of channel 6.

**Blue/Red Wire :** DELAYED 300 mA PULSED OUTPUT / CHANNEL 7

The light blue/red wire pulses to ground via an independent RF channel from the keychain transmitter. This is a transistorized, low current output, and should only be used to drive an external relay coil.

**WARNING:** Connecting the light blue/red to the high current circuits, will damage the control module. Connect the light blue/red to terminal 86 of the AS - 9256 relay (or equivalent 30 A automotive relay) and wire the remaining relay contacts to perform the selected function of channel 7.

**3 Pin Input/Output Harness:**

**Dark Blue/Black Trace Wire:** External Trigger Input

The Dark Blue/Black trace wire allows the remote start unit to be activated from an external source. The intent of this wire is to allow the unit to be controlled from a "POSSE/CAR-LINK" paging system or similar device. When this wire receives a ground pulse, the unit will start the vehicle. Connect this wire to a ground pulsed output from the controlling circuit.

**Green w/ White Trace Wire:** Entry Illumination Ground Output

This wire provides a 30 second ground output (300 mA Max.) whenever the remote is used to unlock the doors. This wire should be connected to an external relay, and wired to the vehicles interior entry lighting whenever the optional Interior Illumination circuit is desired. See below for relay wiring details.

**Black w/ White Trace Wire:** 300 mA Horn Output

The black w/ white trace wire is provided to beep the vehicle's horn. This is a transistorized low current output, and should only be connected to the low current ground output from the vehicle's horn switch.

If the vehicle uses a + 12 VDC horn switch, then connect the black w/ white trace wire to terminal 86 of the AS 9256 relay ( or an equivalent 30 Amp automotive relay ), and connect relay terminal 85 to a fused +12 VDC battery source. Connect relay terminal 87 to the vehicle's horn switch output, and connect relay terminal 30 to a fused + 12 VDC battery source.

**Entry Illumination Detail**

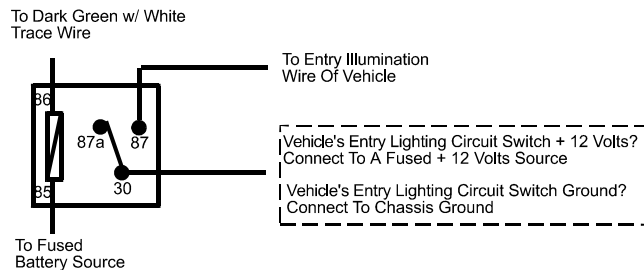

**3 Pin Antenna/Receiver Connector:** (White Connector)

Plug the previously routed antenna connector from the antenna receiver assemble into the mating connector of the control module. This connector supplies 12 volts, ground and RF data from the antenna receiver to the remote start module. Be certain this connector is firmly seated making good contact to the control unit.

**TIMED START PROGRAM:**

The Remote Start unit has the ability to start the vehicle automatically at timed intervals. This feature is useful in extremely cold climates where starting the engine is the only means to keep the battery charged and fluids warm. The operator has the option to have the unit start every 2 or 4 hours for a maximum of 48 hours. Factory preset is to start at 4 hour intervals. To select 2 or 4 hour automatic start timer:

1. Start By Holding the Push Button Switch On.
2. While Holding the Push Button Switch Turn The Ignition Switch On Then Off
- 3a) Within 10 seconds of turning the ignition switch off, Release and then Push On and release the Push Button Switch 2 times holding it on the second time until the siren and or lights flash and chirp 2 times indicating that the 2 Hour Start Interval has successfully been set. or
- 3b) Within 10 seconds of turning the ignition switch off, (Step 2) Release and then Push On and release the Push Button Switch 4 times holding it on the fourth time until the siren and or lights flash and chirp 4 times indicating that the 4 Hour Start Interval has successfully been set.

**NOTE:** Once selected, 2 or 4, this timer interval will remain in memory until it is manually changed. To change, the above sequence will have to be followed.

**TIMED START OPERATION:**

To begin the start timer, within 10 seconds of turning off the ignition switch, activate the RF command to start 2 times. (Press the trunk/key button four times). The lights will flash and the siren will chirp 4 times. Indicating timed interval mode has been initiated. The vehicle will automatically start every 2 or 4 hours as programmed. To cancel the timed start mode start the vehicle either by RF or by the ignition key.

**Programming Tach Rate:**

**NOTE:** All applications require that tach be programmed.

The unit will not operate unless tach is programmed. If an attempt is made to start the vehicle via the remote start without first programming tach, the unit will flash the parking lights 7 times indicating tach has not been learned and stored. If the tach rate is not properly programmed to the specific vehicle, the unit may not realize that the vehicle is running in certain instances and could re-engage the starter motor.

The Remote Car Starter will learn the tach rate of most vehicles single ignition coils, multiple coil packs, and or single injector. To learn tach;

1. Turn the ignition key to the ON position.
3. Press and release the program push-button switch 3 times.
4. Immediately turn the ignition key OFF.
5. Hold the program push-button switch ON, then start the vehicle **using the ignition key**.
6. When the unit senses the tach signal, the parking lights will begin to flash.
7. Release the program push-button switch. The parking lights will turn on for 3 seconds to indicate that the tach signal is stored and the unit is now out of the program mode.

**3. Diagnostics:**

1. Be sure that programmable feature number #9 is set to the "Diagnostics On" mode.
2. Press and hold the program push-button switch on, then turn the ignition key to the "ON" position.
3. The lights will flash and the number of flashes will indicate the reason for shutdown on the last remote start attempt. The indications are as follows.

- 1 Flash** 5, 10, 15, or 20, minute run timer expired.
- 2 Flashes** Low or No tach signal received.
- 3 Flashes** Positive input shut down.
- 4 Flashes** Control switch was moved to "Off" position.
- 5 Flashes** RF Shutdown command received.
- 6 Flashes** High RPM signal over speed shut down.
- 7 Flashes** Tach has NOT learned.
- 8 Flashes** Negative input shut down

**Multi Coil Pack Adapter:** (Optional)

The multi coil pack adapter, (P/N 136B1400), is designed for use with vehicles that do not respond to single coil tach programming. Although the tach resolution of this circuit is designed to interface direct with most vehicles, there may be an occasion where the following circuit may be required.

To use the adapter, the Green/Black wires must connect to the negative side of the ignition coil(s).

1. For vehicles utilizing independent coils per cylinder, connect the three Green/Black leads to alternate coils. To achieve optimum performance the coil signals must be evenly distributed. This is accomplished by first mapping out the firing order of the engine in groups of as indicated below. Draw a circle around any of the columns. The Green/Black wires should be connected to the negative (-) terminal of the respective cylinder number which appears in any of the circles.
2. For vehicles utilizing 2 cylinder firing per coil pack, connect Green/Black to the tach side of each coil pack. For 8 cylinder, four coil systems, connect to any of the three coils.
3. Connect the Yellow wire to a +12 volt ignition 1 source. This wire will have +12 volts with the ignition in the on and start position and have 0 volts with the ignition in the off position.
4. Connect the Green wire to the (Green) or (Orange/Green) tach input of the Audiovox remote start unit.

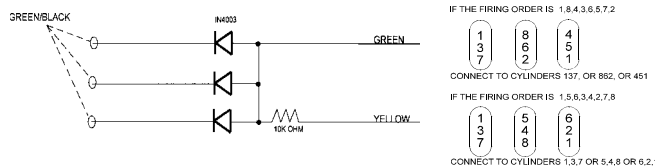

**TESTING YOUR INSTALLATION:**

**WARNING!!** The following procedure must be performed after the installation of an Audiovox Remote Start Device. It is the responsibility of the installing technician to complete these tests. Failure to test the unit in the following manner may result in personal injury, property damage, or both.

**HOOD PIN SAFETY SHUT DOWN:**

The intention of the hood pin safety shut down is to prevent the Remote Start unit from being activated while a mechanic or vehicle owner is performing normal routine vehicle maintenance.

To test the integrity of this circuit:

1. With the driver's window in the down position, start the vehicle using the RF transmitter.
2. Reach inside the car and pull the hood release.
3. Raise the hood and confirm that the remote start unit shuts down.

If the unit fails this test, recheck your pin switch connection to the Gray/Black wire of the Audiovox Remote Start Unit.

**WARNING!!**

**DO NOT RELEASE THIS VEHICLE TO THE CONSUMER UNTIL YOU CONFIRM THE OPERATION OF THE HOOD PIN SAFETY SHUT DOWN FEATURE.**

**MANUAL SHUT DOWN / ENABLE CIRCUIT:**

The intent of the manual shut down / enable circuit is to allow the vehicle operator to prevent operation of the Remote Start Unit regardless of the RF transmitter operation.

- 1) With the system disarmed/unlocked, and the ignition switch off Press and Hold the PRLED on.
- 2) Turn the ignition switch on, off, on, off, on, off.
- 3) The LED begins to flash two short flashes followed by one long flashes and continues this pattern until returned to normal mode of operation.

This puts the unit into the R/S Override mode indicating that the remote start is in the service mode and will not start from RF or any other input Posse or otherwise.

To Exit R/S Override Mode

- 1) With the system disarmed, Press and Hold the PRLED on.
- 2) Turn the ignition switch on, off, on, off, on, off.
- 3) The LED turns off indicating that the R/S unit is fully functional one again.

**WARNING!!**

**DO NOT RELEASE THIS VEHICLE TO THE CONSUMER UNTIL YOU CONFIRM THE OPERATION OF THE MANUAL SHUT DOWN / ENABLE FEATURE.**

**NEUTRAL START SAFETY TEST:**

The intent of the neutral start switch is to prevent the vehicle from starting while the gear selector is in any position other than Park, or Neutral. When installing a Remote Start Device, it is imperative that the Yellow Starter wire be connected to the ignition switch side of the Neutral Start Switch. Consideration for the placement of a starter inhibit relay is important as well, and should be connected to the ignition switch side of the Yellow Start Wire.

To test the integrity of the Neutral Start Safety Circuit:

1. Set the vehicle parking brake.
2. Block the drive wheels to prevent vehicle movement.
3. Temporarily disconnect the Brown/Black positive shut down wire from the vehicle's brake switch.
4. Sitting in the vehicle, start the engine using the vehicle's ignition key.
5. Step on the brake pedal and shift the gear selector into reverse.
6. Allow the transmission to shift. When you feel the engine pull, do not move the gear selector just turn the ignition switch off. DO NOT attempt to remove the key.
7. Keeping the brake pedal depressed, activate the RF transmitter in an attempt to start the vehicle. The car should not start.
8. Repeat the above test this time move the gear selector to the drive position. If the unit attempts to start, failing this test, recheck your Yellow Wire's connection. This wire must be connected to the ignition switch side of the Neutral Start Switch. If the vehicle you are working on does not have an Electrical Neutral Safety Switch, it will be necessary to reconfigure the Remote Starts Wiring to accommodate this vehicle.



The information concerning the Mechanical Neutral Safety Switch provided below will help you to determine if the vehicle you are working on has this type of safety switch and will provide alternate wiring methods to accommodate this situation.

**WARNING!!**

**REMEMBER TO RECONNECT THE BROWN/BLACK WIRE TEMPORARILY DISCONNECTED IN STEP 3.**

**DO NOT RELEASE THIS VEHICLE TO THE CONSUMER UNTIL YOU CONFIRM THE OPERATION OF THE NEUTRAL SAFETY START FEATURE.**

**MECHANICAL NEUTRAL SAFETY SWITCH CONSIDERATIONS:**

Mechanical neutral safety switch configurations differ slightly in that they do not offer the same level of safety when installing a remote start device. Often when the ignition switch is turned off while the gear selector is in any position other than park or neutral, the mechanical function will not allow the key to be turned to the start position or be removed from the ignition cylinder. This configuration prevents mechanical operation while the vehicle is in gear but offers no consideration for electrical operation. Because of this potential problem, this installation requires the additional connection of a safety wire from the remote start device to the vehicle Park/Neutral ECM Input or the vehicle key in sensor. This connection will prevent remote start operation if the key is left in the ignition switch regardless of the gear selector position.

**PARK / NEUTRAL ECM INPUT:**

The Park / Neutral ECM input is the preferred method of installation. This not only maintains the integrity of the factory circuit, it is also the easiest to install, providing the vehicle you are working on has this ECM input. The installation required for this application (shown below), indicates the slight reconfiguration of the control switch wiring and the addition of a 4000 series diode. Shown is a typical GM Park/Neutral ECM input circuit. To connect the Audiovox remote start unit to the GM Park / Neutral ECM input:

1. Locate the Orange / Black reference wire in the "C2" connector found at the ECM in GM B Body vehicles or, locate the equivalent reference wire in the vehicle you are installing the Audiovox Remote Start Unit in.
2. Connect the Cathode, (Striped) end, of a 4000 series diode to this reference wire.
3. Connect the Anode, (Non Striped) end, of the diode to one side of the Remote Start enable switch.
4. Connect the other side of the enable switch to the Black/White enable input wire of the Remote Start unit.

The reference diagram below shows a typical GM B Body ECM reference wire and how it is to be connected to the Remote Start Unit.

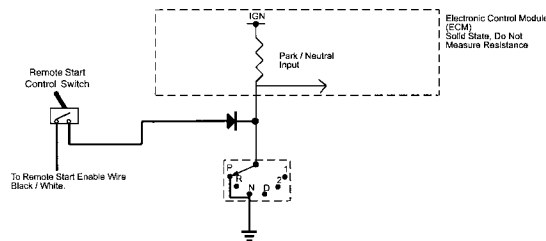

**KEY IN SENSOR CIRCUITS:**

If the vehicle you are working on does not have or you cannot locate the ECM reference wire, there are two alternatives available. Although not preferred, the vehicle Key In Sensor may be reconfigured to allow a margin of safety and will prevent the vehicle with a Mechanical Neutral Start Switch from starting in gear.

AUDIOVOX ADVISES THAT YOU MAINTAIN THE FACTORY CIRCUIT WHENEVER POSSIBLE. The following two circuits may be used only if the above circuit is not available.

**NOTE:** When completing an installation using either of the following key in sensor circuits, if the operator inserts the ignition key while the vehicle is running under the control of the Remote Start, the vehicle will shut down. This must be explained to the operator as it is in contrast to the normal operation of a vehicle utilizing an electrical neutral start switch and is inconsistent with the operator's manual.

Additional information concerning Key In Sensor methods 1 & 2 are listed below and should be reviewed before considering either alternative.

**Method 1** will allow the safety required for the remote start unit and prevent the vehicle from starting while in any gear other than Park or Neutral while the key is in the ignition cylinder. However, if the key is left in the ignition switch and the door is left opened, the added relay will be energized causing a 150mA drain on the battery.

**Method 2** will allow the safety required for the remote start unit and prevent the vehicle from starting while in any gear other than Park or Neutral while the key is in the ignition cylinder. However, the original factory key in chime module will not alert the owner that the key has been left in the ignition switch. In addition, this may also effect other warning tones such as the light on reminder.

These situations should be carefully considered before altering the vehicle's wiring and must be fully explained to the consumer.

Circuits may be used only if the above circuit is not available.

**METHOD 1**

To connect to the key in sensor as shown in method 1:

- A. Locate the control wire that connects the drivers door pin switch to the key in sensor switch.
- B. Cut this wire and connect the ignition cylinder side to chassis ground.
- C. Locate the key in sensor switch wire that connects the chime module to the ignition cylinder .
- D. Cut this wire and connect the ignition cylinder side to terminal #30 of a P&B VF45F11 or equivalent relay.
- E. Connect the cathode (striped) side of a 4002 series diode to this same wire, and connect the (non striped) side to the negative shut down safety wire (Gray / Black) of the Audiovox Remote Start Unit.
- F. Connect terminal #86 of the relay to a fused +12 volt constant battery source.
- G. Connect terminal #87 of the relay to the Chime Module side of the previously cut wire in step D.
- H. Connect terminal #85 of the relay to the Drivers Door side of the pin switch wire previously cut in step B.

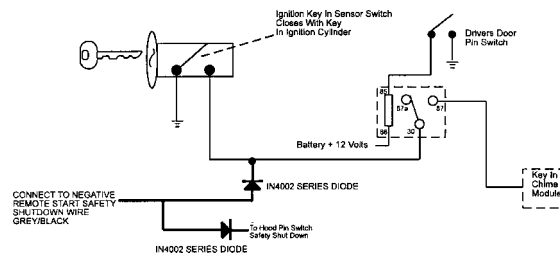

**NOTE:** A second 4002 series diode may be required to maintain the integrity of the hood open, shut down circuit. If this is the case, it must be installed as shown in the diagram above. The anode (Non Striped) side must be connected to the Gray/Black wire of the Remote Start Unit. The cathode (Striped) side must be connected to the hood pin switch. If the hood pin switch is also used for an alarm trigger input, be certain to use the dual diode assembly packaged with the Audiovox Remote Start Unit as shown following.

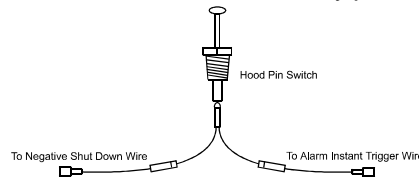

**METHOD 2**

To connect to the key in sensor circuit as shown for method 2:

- A. Locate the control wire that connects the drivers door pin switch to the key in sensor switch.
- B. Cut this wire and connect the ignition cylinder side to chassis ground.
- C. Locate the key in sensor switch wire that connects the chime module to the ignition cylinder .
- D. Cut this wire and connect the ignition cylinder side to the Remote Start Negative Safety Shut down Wire Gray/Black, using a 4002 series diode as shown above.

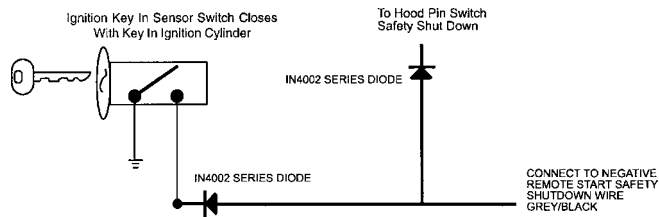

**NOTE:** A second 4002 series diode may be required to maintain the integrity of the hood open, shut down circuit. If this is the case, it must be installed as shown in the diagram above. The anode (Non Striped) side must be connected to the Gray/Black wire of the Remote Start Unit. The cathode (Striped) side must be connected to the hood pin switch. If the hood pin switch is also used for an alarm trigger input, be certain to use the dual diode assembly packaged with the Audiovox Remote Start Unit as shown in this installation guide.

AFTER THE CONNECTION OF THE NEUTRAL START SAFETY WIRE AS INDICATED IN ANY OF THE PREVIOUS ALTERNATE CONFIGURATIONS, THIS CIRCUIT MUST BE TESTED FOR OPERATION. Retest by following the steps outlined in the NEUTRAL START SAFETY TEST shown in this manual.

**4 Pin Upgrade Telematic Module:**

**Red = + 5 Volts**

**Black = Ground**

**White = Data TX**

**Yellow = Data RX**

If used, connect the 4 pin harness from the Telematic one way module kit to the mating port on the controlling circuit. **NOTE:** If using the TWO WAY Telematic module, only Ground, TX, and RX are used on this port, the + 12 volt supply for the two way module must be sourced separately or the unit will not operate.

**4 Pin Upgrade Data Bus/Flash Logic Module:**

If you are using an Audiovox Flash Logic module, it can be connected directly to the Alarm/Remote Start's control module. Using the Blue 4 pin blue, red, black, & white harness and connect to the mating connector on the Alarm/Remote Start control module. Wire the Flash Logic/Data Bus module to the vehicle as prescribed in it's installation guide.

**COMPLETING THE INSTALLATION:**

After you have confirmed the operation of the Audiovox Remote Start unit and tested all the safety features of the system:

1. If you have not done so already, place the red rubber handle cover over the handle of the control switch for ease of identification. This will allow your customer to distinguish the Remote Start control switch from the program switch.
2. Mount the control module up and behind the dash securing it in place with cable ties or screws. Be certain that the chosen mounting location will not inhibit any of the controls of the vehicle.
3. Securely harness and tie all wiring up and away from all hot and moving parts that they may come in contact with

under the dash board or in the engine compartment areas.

**CAUTION:** Particularly avoid the area around the steering shaft and column, as wires can wrap around these mechanisms and impair the safe operation of the vehicle.

4. Apply the Caution Labels supplied with this kit to a conspicuous area in the engine compartment. Make sure to clean the surface before affixing the label.
5. Check the vehicle's wipers, lights, horn, etc.... to insure proper operation.
6. Replace all panels that were removed during installation, and retest the system.
7. Explain all activated features and safety systems associated with Remote Start Unit installed to the customer.

