



# MODEL 28000

## ARTICULATING CRANE

### OWNERS' MANUAL

Safety • Operation • Maintenance • Installation • Parts

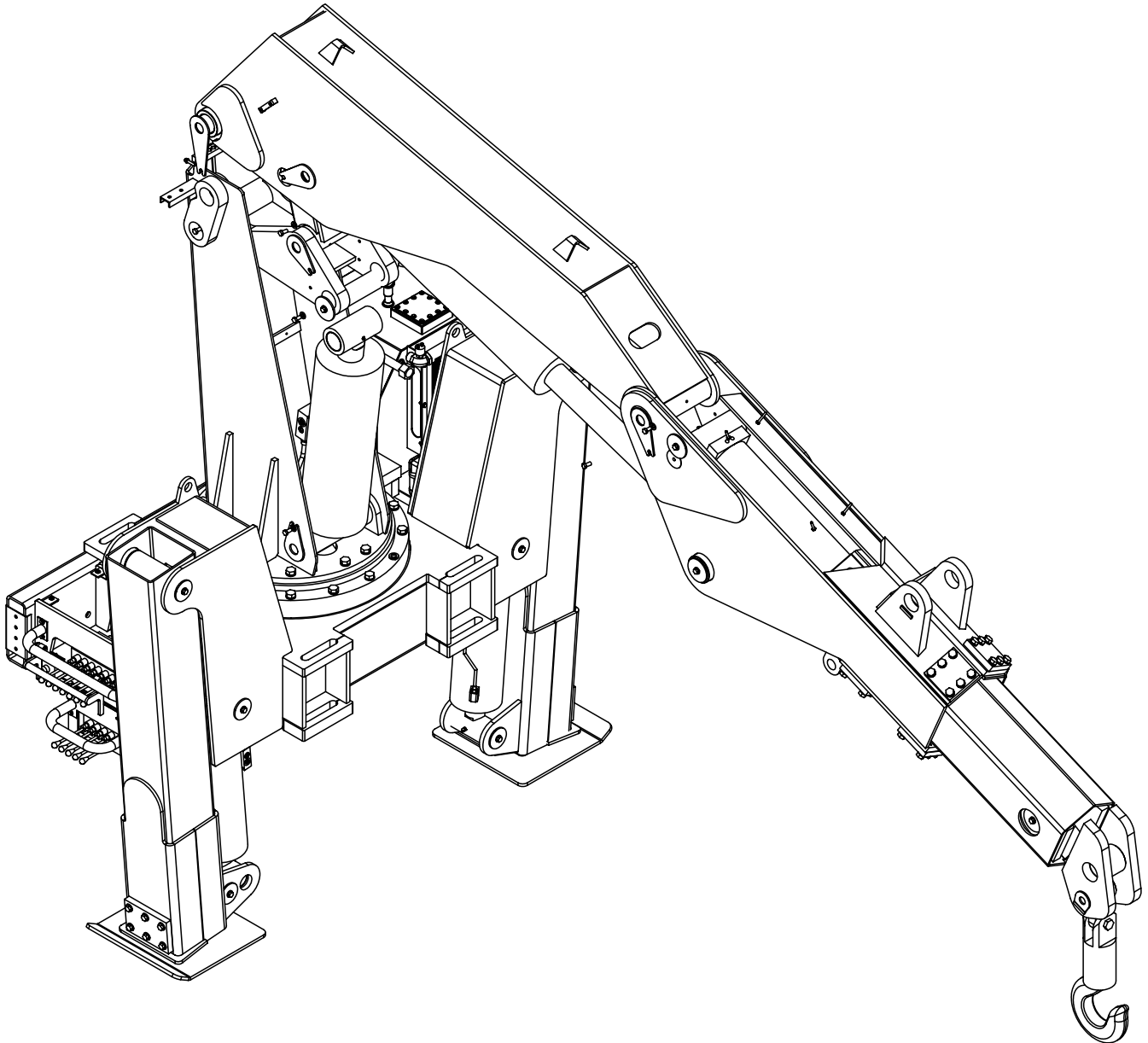

**Stellar Industries, Inc.**

190 State Street

PO Box 169

Garner, IA 50438

800-321-3741

Fax: 641-923-2811

[www.stellarindustries.com](http://www.stellarindustries.com)

Subject to Change without Notification.  
© 2011 Stellar Industries, Inc.

Last Revision: 08/31/12

# 28000 Manual Revisions

Date of Revision	Section Revised	Description of Revision
November 6, 2008	<b>Chapter 2:</b> Operation <b>Chapter 5:</b> Decals <b>Chapter 7:</b> Assembly Drawings <b>Chapter 8:</b> Hydraulics - Electrical	Updated drawings to reflect engineering changes. Updated drawings include: Decal Kit Placement, Reservoir Assembly, Base Assembly, Outrigger Assembly, Control Kit, Hydraulic Kit
May 7, 2010	<b>Chapter 7:</b> Assembly Drawings <b>Chapter 8:</b> Hydraulics - Electrical	Updated drawings to reflect engineering changes. Updated drawings include: Main Boom Assembly, Extension Boom Assembly, Control Kits, Hydraulic Kit

# Table of Contents

---

Introduction .....	.ii
<b>Chapter 1 - Safety .....</b>	<b>.1</b>
<b>Chapter 2 - Operation .....</b>	<b>.3</b>
Unit Operation Overview .....	.3
Manual Operation .....	.4
Radio Remote Operation .....	.4
Hook Precautions .....	.5
Crane Transport .....	.5
Crane Precautions .....	.5
Operator Information .....	.6
<b>Chapter 3 - Maintenance .....</b>	<b>.7</b>
Lubrication Recommendations .....	.9
Torque Data Chart .....	.10
Inspection Checklist .....	.11
Daily Inspection .....	.12
Monthly Inspection .....	.13
Quarterly Inspection .....	.14
Annual Inspection .....	.16
Inspection Notes .....	.17
<b>Chapter 4 - Specifications .....</b>	<b>.19</b>
Capacity Chart - Decal PN 16055 .....	.20
<b>Chapter 5 - Decals .....</b>	<b>.21</b>
Decals of Note .....	.21
Decals of Note Continued... ..	.22
Decal Kit - PN 16658 .....	.23
<b>Chapter 6 - Installation .....</b>	<b>.25</b>
Installation Overview .....	.25
Installation Notice .....	.25
General Installation .....	.25
Mounting Kit Drawing 16659 .....	.26
<b>Chapter 7 - Assembly Drawings .....</b>	<b>.27</b>
Base Assembly - PN 47880 .....	.27
Mast Assembly - PN 18073 .....	.28
Main Boom Assembly - PN 55106 .....	.29
Main Boom Cylinder Assembly - PN 20694 .....	.30
Extension Boom Assembly - PN 55108 .....	.31
Extension Boom Cylinder Assembly - PN 50628 .....	.32
Outrigger Assembly - PN 48689 .....	.33
Outrigger Cylinder Assembly - PN 48383 .....	.34
Reservoir Assembly - PN 41332 .....	.35
Optional 15 Ton Hook Kit - PN 55138 .....	.36
<b>Chapter 8 - Hydraulics - Electrical .....</b>	<b>.37</b>
Control Kit - PN 41919 .....	.38
Control Kit (434 Mhz Option) - PN 51838 .....	.39
Control Kit (419 Mhz Option) - PN 55395 .....	.40
Hydraulic Kit - PN 48690 .....	.41
<b>Chapter 9 - Replacement Parts .....</b>	<b>.43</b>
<b>Chapter 10 - Troubleshooting .....</b>	<b>.45</b>
BMS-2 Receiver Troubleshooting .....	.50
Warranty Information .....	.52

# Introduction

Stellar Cranes are designed to provide safe and dependable service for a variety of operations. With proper use and maintenance, these cranes will operate at peak performance for many years.

To promote this longevity, carefully study the information contained in this manual before putting the equipment into service. Though it is not intended to be a training manual for beginners, this manual should provide solid guidelines for the safe and proper usage of the crane.

Once you feel comfortable with the material contained in this manual, strive to exercise your knowledge as you safely operate and maintain the crane. This process is vital to the proper use of the unit.

### A few notes on this manual:

A copy of this manual is provided with every crane and shall remain with the crane at all times. Information contained within this manual does not cover all maintenance, operating, or repair instructions pertinent to all possible situations.

Please be aware that some sections of this manual contain information pertaining to

Stellar manufactured cranes in general and may or may not apply to your specific model.

This manual is not binding. Stellar Industries, Inc. reserves the right to change, at any time, any or all of the items, components, and parts deemed necessary for product improvement or commercial/production purposes. This right is kept with no requirement or obligation for immediate mandatory updating of this manual.

### In closing:

If more information is required or technical assistance is needed, or if you feel that any part of this manual is unclear or incorrect, please contact the Stellar Customer Service Department by phone at 800-321-3741 or email at [service@stellarindustries.com](mailto:service@stellarindustries.com).

**ATTENTION**  
**Failure to adhere to the instructions could result in property damage or even serious bodily injury to the operator or others close to the crane.**

**For Technical Questions, Information, Parts, or Warranty, Call Toll-Free at  
800-321-3741**

Hours: Monday - Friday, 8:00 a.m. - 5:00 p.m. CST

Or email at the following addresses:

**Technical Questions, and Information**

[service@stellarindustries.com](mailto:service@stellarindustries.com)

**Order Parts**

[parts@stellarindustries.com](mailto:parts@stellarindustries.com)

**Warranty Information**

[warranty@stellarindustries.com](mailto:warranty@stellarindustries.com)

# Chapter 1 - Safety

**Please Read the Following Carefully!** This portion of the manual contains information regarding all Stellar manufactured cranes. Some items contained within this chapter may not apply to your specific equipment.

Safety should be the number one thought on every operator's mind. Three factors should exist for safe operation: a qualified operator, well-maintained equipment, and the proper use of this equipment. The following information should be read and understood completely by everyone working with or near the crane before putting the unit into operation.

Please take note that Stellar Industries, Inc. is not liable for accidents incurred by the crane because of non-fulfillment from the operator's side of current rules, laws, and regulations.

## GENERAL

It is the responsibility of the owner to instruct the operator in the safe operation of your equipment and to provide the operator with properly maintained equipment.

Trainees or untrained persons shall be under the direct supervision of qualified persons.

Do not operate equipment under the adverse influence of alcohol, drugs, or medication.

## PERSONAL SAFETY

Keep clear of all moving parts.

Always wear the prescribed personal safety devices.

Always wear approved accident-prevention clothing such as: protective helmets, anti-slip shoes with steel toes, protective gloves, anti-noise headphones, protective glasses, and reflective jackets with breathing apparatus. Consult your employer regarding current safety regulations and accident-prevention equipment.

Do not wear rings, wristwatch, jewelry, loose-fitting or hanging clothing such as ties, torn garments, scarves, unbuttoned jackets or unzipped overalls, which could get caught up in the moving parts of the crane.

Keep a first-aid box and a fire extinguisher readily available on the truck. Regularly check to make sure the fire extinguisher is fully charged and the first-aid kit is stocked.

Do not use controls and hoses as handholds. These parts move and cannot provide stable support.

Never allow anyone to ride the crane hook or load.

## MAINTENANCE SAFETY

Never modify or alter any of the equipment, whether mechanical, electrical, or hydraulic, without explicit approval from Stellar Industries.

Do not perform any maintenance or repair work on the crane unless authorized and trained to do so.

Release system pressure before attempting to make any adjustments or repairs.

Do not attempt service or repair when the PTO is engaged.

Failure to correctly plumb and wire the crane can cause a malfunction and damage to the crane and/or operator.

Decals are considered safety equipment. They must be maintained, as would other safety devices. Do not remove any Decals. Replace any Decals that are missing, damaged, or not legible. The safety instruction plates, notices, load charts and any other sticker applied to the crane or service body must be kept legible and in good condition. If necessary, replace them.

## STABILITY

Know the crane components and their capabilities and limitations. Overloading the crane may result in serious injury to self and others, and damage to the equipment and immediate surroundings.

Never exceed manufacturer's load ratings. These ratings are based on the machine's hydraulic, mechanical, and structural design rather than stability.

The supporting surface under the service truck must be able to support the weight of the machine and its load. Use outrigger pads if necessary.

Park the vehicle on level ground and extend the outriggers fully out and then down.

Keep feet and legs clear when lowering outrigger jacks.

Never operate the crane without making sure the outriggers are positioned on stable, flat ground.

Set the parking brake and disengage the drive axle before attempting a lift.

### LOAD SAFETY

Operate the crane in compliance with the load capacity chart at all times. Know the weight of the load being lifted. Do not rely on the overload device to determine maximum rated loads.

Never use a sling bar or anything larger than the hook throat that could prevent the hook latch from closing. This would negate the safety feature.

Do not apply side loads to the booms.  
Do not leave a crane load suspended or unattended.

Do not walk under suspended loads.

Do not position any load over a person nor should any person be permitted to place him or herself under a load.

Do not use the boom or the winch to drag a load.

Do not use the crane boom to push downward onto anything.

### ELECTROCUTION

Allow extra space for swaying power lines in windy conditions.

Keep a minimum of ten feet between any portion of the crane and an electrical line. Add an additional 12" for every additional 30,000 Volts or less.

Remember - Death or serious injury can occur when working near power lines or during electrical storms.

Use a signal person when operating near electrical sources.

### ENVIRONMENT

Do not operate the crane during electrical storms.

In extreme cold, allow adequate time to warm the truck before engaging the PTO. Do not rev the truck engine and over speed the hydraulic pumps as permanent damage to the pumps may occur. Follow the vehicle owner's manual regarding operating the vehicle in such adverse conditions.

In dusty work areas, every effort must be taken to keep dust and sand out of the moving parts of the machinery.

In high humidity work areas, keep parts as dry as possible and well lubricated.



## Crane Controls

1. Be familiar with the sequence and operation of the crane controls.
2. Each individual crane function should have control function decals. Replace them immediately if they are missing or illegible.
3. Keep hands, feet and control levers free from mud, grease and oil.
4. Be familiar with the remote control and how it operates before attempting to lift a load.
5. Be prepared before beginning operation of the crane:
  - All protective guards must be in place.
  - Be aware of the surroundings: low branches, power lines, unstable ground.
  - Be sure all safety devices provided are in place and in good operating condition.
  - Be prepared for all situations. Keep fire extinguisher and first aid kit near.
  - Be sure all regular maintenance has been performed.
  - Visually inspect all aspects of the crane for physical damage.
  - Check for fluid leaks.
  - Make sure the outriggers are down and stable.

### ATTENTION

**Stellar Industries, Inc. is not liable for accidents incurred by the crane because of the operator's non-fulfillment of current rules, laws and regulations**



# Chapter 2 - Operation

This chapter contains information regarding the operation of Stellar manufactured articulating cranes. Please study the following pages to ensure your familiarity with the operation process. This understanding is vital to the safe and efficient operation of the crane.

## Job-Site Set-Up

**Thoroughly plan the lift before positioning the vehicle. Consider the following:**

1. The vehicle should be positioned in an area free from overhead obstructions to eliminate the need for repositioning.
2. Position the vehicle so that it is impossible for any portion of the equipment to come within the minimum required safe distance of any power line. Maintain a clearance of at least 10 feet between any part of the crane, load line, or load, and any electrical line or apparatus carrying up to 50,000 volts. One foot additional clearance is required for every additional 30,000 volts or less. Remember to allow for winds that cause power lines to sway. It is recommended that a signal person be used when the vehicle is set-up near power lines.
3. The vehicle should also be positioned on a firm and level surface that will provide adequate support for the outrigger loading. Use extreme caution when setting up near overhanging banks or excavations.
4. The parking brake must be set on the vehicle and the drive axle disengaged before performing a crane operation.
5. The outriggers must be extended to stabilize the truck before beginning operation.

## NOTICE

**The parking brake must be fully engaged in order to operate any Stellar Equipment.**

## Unit Operation Overview

1. Engage the PTO
2. Turn on Power to Crane
3. Position Outriggers
4. Operate Crane
5. Store Outriggers
6. Turn Off Power to Crane
7. Disengage the PTO

### 1. Engage the PTO

- A. Engage the **parking brake**.
- B. Place the transmission in the Neutral position.
- C. Make certain the PTO switch is in the 'off' position.
- D. Start the vehicle engine.
- E. Depress the clutch on manual transmission vehicles.
- F. Engage the PTO switch for cable and air type shifters. Turn on the dash switch for electrical operated style. Consult vehicle owner's manual for location and operation of OEM style in-dash PTO switch.
- G. Slowly release the clutch on a manual transmission vehicle.
- H. Allow a few moments to warm the hydraulic system oil. In cold weather, it is especially important to let the system run for a few minutes before operating.



PTO Switch

### 2. Turn on Power to Crane

Activate power to the crane and outriggers. The power switch is located on the control panel in the vehicle cab.

### 3. Position Outriggers

Once the PTO is engaged, extend the outriggers using the control levers or switches marked 'outrigger'. These may be located on the crane base or in the compartment under the crane.

### 4. Operate Crane

- A. Turn on necessary power to the crane.
- B. Activate toggle switch for desired crane function. See the Hetricon Remote Manual for detailed information.
- C. When operation is complete, store remote handle in a safe, dry location.

### 5. Store Outriggers

Retract outriggers using the control levers or switches marked 'outrigger'.

### 6. Turn Off Power to Crane

Deactivate power to crane and outriggers.

### 7. Disengage the PTO

- A. On manual transmission vehicles, depress the clutch pedal completely.
- B. Disengage the PTO switch.
- C. If vehicle is a manual transmission, release the clutch pedal gradually.

## Radio Remote Operation



The crane is operated by a radio control system which operates an electronic valve bank. The controller (as shown above) operates the following functions:

- Main Boom Up and Down
- Outer Boom Up and Down
- Extension Boom In and Out
- Rotation Clockwise and Counter-Clockwise
- TireMan Clockwise and Counter-Clockwise
- TireMan Pad Clockwise and Counter-Clockwise
- TireMan Open and Close

Note: If the crane does not operate, check the batteries located in the remote handle and replace if necessary.

### Start Up Procedure

For a more detailed version of this procedure, please see the BMS-2 Remote Manual.

1. Be sure that all controls, joysticks or paddle levers are in the Off (neutral) position. NOTE: If any control, joystick or paddle lever is NOT in the Off (neutral) position when the Start/Horn button is pushed, the transmitter will not transmit.
2. Switch the transmitter "ON". A short buzzer signal will sound.
3. Wait for the second buzzer signal (approx. 3 seconds).
4. Turn the E-Stop to release.
5. Press the Start/Horn button.
6. The green LED on the transmitter control panel will flash. This indicates that the transmitter is working and is ready to use.
7. Check that the machine functions correspond with the transmitter functions. The receiver display will change according to which motion is activated.

### Note About Battery Condition

The batteries included with this equipment may be rechargeable. To keep rechargeable batteries in optimal working condition, follow these simple guidelines:

1. Keep battery away from moisture. Store in a cool, dry location.
2. Do not store or carry battery so that metal objects can contact exposed metal end. Keep battery cap on when not in use.
3. The batteries should be recharged when they fail to produce sufficient power.
4. Never attempt to open the battery for any reason.

## Manual Operation

In case of radio failure, the crane can be operated using manual overrides located on the valve bank.

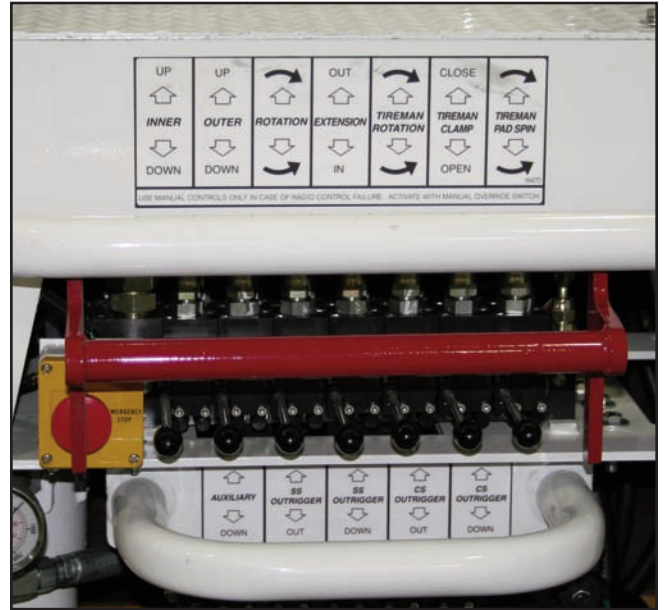

### Valve Manual Override Operation

#### 1. Switch to Manual Operation:

Flip the toggle switch (shown below) up to "Manual"

#### 2. Operate Levers on the Valve Bank:

Push or pull levers to operate listed function.

#### 3. Switch Controls Off:

Flip the toggle switch to the middle "Off" position.

#### 4. Have Unit Serviced.





### Crane Precautions

1. Movement of the control levers should be slow and smooth to meter oil flow for safe operation. Avoid jerky and sudden movements.
2. The crane controls should be clearly marked with decals. If these are missing or illegible, replace immediately. (See Chapter 5: Decals)
3. Lift load slightly off the ground to check the safety of the cargo. Do not use stability to determine the safety. Consult the capacity charts and strictly adhere to them.
4. Be constantly aware of the boom position when operating the controls.
5. The boom tip should be centered directly over the load before making the lift to avoid swinging.
6. Do not drag loads with the crane.
7. Do not attempt to lift fixed loads.
8. Do not load boom in a sideways direction.
9. Know the weight of the rigging and load to avoid overloading the crane.
10. Do not extend or rotate a load over anyone.
11. Wear protective gear such as hard hat, safety glasses, steel-toed boots, and gloves.

### Crane Transport

#### Before transporting the crane, do the following:

1. The crane must be in the stored position.
2. Outriggers must be securely stowed and not extended horizontally or vertically.
3. Hook and sheave assemblies must be securely fastened to prevent swinging.
4. All loose accessories, tools, and remote controls must be securely stored in their respective compartments or fasteners.
5. The PTO must be disengaged.
6. The parking brake must not be released until all of the above procedures are completed.
7. Do not drive the carrier vehicle while a load is present on the hook.
8. Do not drive the carrier vehicle with less than proper tire inflation.
9. Do not drive the carrier vehicle in areas where the vertical clearance is unknown.
10. Do not allow personnel to ride on the equipment during transport.

### Hook Precautions

1. Hooks are designed and manufactured to lift specific loads. The specified rated load of a hook applies to loads held uniformly in direct tension and does not take into account shock loads, hook tip loading, side loading, bending, torsional, or related loads.
2. Do not attempt to lift a load that is larger than the load rating of the hook.
3. Never use a hook's yield point as an indicator of its capacity.
4. Do not use a hook to lift personnel.
5. Know the rated load of the hook in use.
6. Never weld attachments to a finished hook in field applications. This will alter and destroy the design properties of the hook material.
7. Keep fingers, hands, body, and loose clothing from between the hook and the load.
8. Avoid shock loading.
9. Inspect the hook regularly for excessive wear and maintain it in safe operating condition.



The crane **MUST** be in the stored position before transporting.

# Operator Information

## OPERATOR REQUIREMENTS

- 1. Operation is limited to the following people:**
  - A. Designated individual.
  - B. Trainees under direct supervision of the designated individual.
  - C. Test or maintenance individual.
  - D. Crane Inspector.
  
- 2. Operators must meet the following physical qualifications:**
  - A. Vision of at least 20/30 Snellen in one eye and 20/50 in the other, with or without corrective lenses.
  - B. Ability to distinguish colors if color differentiation is required.
  - C. Adequate hearing, with or without a hearing aid.
  - D. No physical or emotional defects that may create a hazard to the operator or others.
  - E. Normal depth perception and coordination.
  
- 3. In addition to the physical qualifications, Operators must:**
  - A. Demonstrate the ability to understand all decals, the owner's manual, and any other information required for safe operation of the crane.
  - B. Be able to demonstrate the ability to safely control the crane.
  - C. Know all safety regulations.
  - D. Be responsible for maintenance requirements.
  - E. Understand and be fully capable of implementing all emergency procedures.
  - F. Understand the operating procedures as outlined by this manual, ANSI B30.2, and Federal/State Laws.

## OPERATOR CONDUCT

1. Operators will not engage in any operation that would cause them to divert attention away from the operation of the crane.
2. Operators are responsible for all operations under their direct control.
3. Operators will not leave a suspended load unattended.
4. Operators will be familiar with the equipment and the maintenance required for proper care.

## HANDLING THE LOAD

- 1. Size of the load:**
  - A. Do not load the crane beyond the rated capacity.
  - B. It is the responsibility of the operator to know the weight of the handled load.
  
- 2. Attaching the load:**
  - A. Attach the load to the hook by means of slings or other approved devices.
  - B. Do not wrap the hoist rope around the load.
  
- 3. Moving the load:**
  - A. Make certain that the crane is level and properly blocked.
  - B. Ensure that the load is secure and balanced within the sling before moving it.
  - C. Be sure that the crane is stable before moving the load. Use stabilizer pads to ensure the proper distribution of weight.
  - D. Do not drag the load sideways.
  - E. Make sure the hook is brought over the load to minimize swinging.
  - F. No suspended load should pass over a person.
  - G. Avoid sudden starts and stops when moving a load.

# Chapter 3 - Maintenance

## **WARNING - Read the Following before performing any maintenance on the crane.**

1. Only authorized service personnel are to perform maintenance on the crane.
2. Disengage the PTO before any service or repair is performed.
3. Do not disconnect hydraulic hoses while there is still pressure in those components.
4. Before disconnecting hydraulic components, place the boom on the ground or have it supported, shut off the engine, release any air pressure on the hydraulic reservoir, and move pedals and control levers repeatedly through their operating positions to relieve all pressures.
5. Keep the crane and service body clean and free from grease build-up, oil and dirt to prevent slippery conditions.
6. Perform all safety and maintenance checks before each period of use.
7. Replace parts with Stellar Industries, Inc. approved parts only.
8. Immediately repair or have repaired any components found to be inadequate.

## **Maintenance Procedures**

1. Position the crane where it will be out of the way of other operations or vehicles in the area.
2. Be sure boom is lowered to the ground or otherwise secured from dropping.
3. Place all controls in the off position and secure operating features from inadvertent motion.
4. Disconnect power source.
5. Relieve hydraulic oil pressure from all hydraulic circuits before loosening or removing hydraulic components.
6. Label or tag parts when disassembling.

## **Daily Inspection**

*Daily Inspection should occur each day before the crane is put into use. Each day, inspect the crane for all of the following:*

1. Hydraulic oil level.
2. Loose parts or damage to structures or weld.
3. Cylinder movement due to leakage.
4. Hoses and gearboxes for evidence of oil leaks.
5. Controls, including hand throttle for malfunction or adjustment.
6. Truck hand brake operation.
7. All securing hardware such as cotter pins, snap rings, hairpins, and pin keepers for proper installation.
8. All safety covers for proper installation.
9. Cylinder holding valves for proper operation.
10. Wire rope for broken wires, extensive wear, distortion, and heat damage.

## **Periodic Inspection**

*Periodic Inspection should occur while the crane is in use. For the duration of the usage, inspect the crane for all of the following:*

1. Loose bolts and fasteners.
2. All pins, bearings, shafts, and gears for wear, cracks, or distortion to include all pivots, outriggers, sheave pins, and bearings.
3. Hydraulic systems for proper operating pressure.
4. Main frame mount bolts.
5. Cylinders for:
  - A. Damaged rods.
  - B. Dented barrels.
  - C. Drift from oil leaking internally.
  - D. Leaks at rod seals or holding valves.
6. PTO drive line system for proper alignment, lubrication, and tightness.
7. Hydraulic hose and tubing for evidence of damage such as blistering, crushing, or abrasion.

**Weekly Inspection**

*Weekly Inspection should occur at the beginning of every work week. Each week, inspect the crane for all of the following:*

1. Lubrication of points required by lubrication chart located in this chapter.
2. Proper operation of load hook safety latch.
3. Presence of this owner's manual.

**Monthly Inspection**

*Monthly Inspection should occur at the beginning of every work month. Each month, inspect the crane for all of the following:*

1. Frame bolt tightness - turn barrel nuts and mounting bolts during the first month of operation on new machines and then quarterly thereafter.
2. Cylinders and valves for leaks.
3. Lubrication.
4. Load hook for the following:
  - a. Cracks or having more than 5% normal throat opening.
  - b. Any visible bend or twist from the plane of the unbent hook.
5. Structural members for bends, cracks, or broken members.
6. All welds for breaks and cracks.
7. All pins and keepers for proper installation.
8. All control, safety, and capacity placards for readability and secure attachment.
9. Inspect all electrical wires and connections for worn, cut, or deteriorated insulation and bare wire. Replace or repair wires as required.
10. Tightness of all boom wear, pad-retaining bolts.

**Service**

*The following general suggestions should be helpful in analyzing and servicing your crane. Using the following systematic approach should be helpful in finding and fixing problems:*

1. Determine the problem.
2. List and record possible causes.
3. Devise checks.
4. Conduct checks in a logical order to determine the cause.
5. Consider the remaining service life of components against the cost of parts and labor necessary to replace them.
6. Make the necessary repair.
7. Recheck to ensure that nothing has been overlooked.
8. Functionally test the new part in its system.

**Inspection Checklist**

For a more detailed outline of scheduled inspection points, refer to the Stellar Inspection Checklist at the end of this chapter. This list is an excellent guide for the inspection tasks that will help maintain the quality of your Stellar product. Feel free to photocopy the checklist as needed.

**ATTENTION**

**Every six (6) months, remove the hydraulic pump from the PTO and lubricate the splines using Chelsea Lubricant #379831 or Stellar PN 20885. Failure to lubricate shaft splines will cause damage to the PTO and Hydraulic pump.**

**Stellar Industries recommends the first filter change to occur after the first 250 hours of service.\* The second, and every subsequent change, should occur after every 1,000 hours of service. By following these guidelines, the hydraulic oil should last up to 6,500 hours.**

\*Note: These recommendations are based on normal working parameters. If operating in less than favorable conditions (excessive dust, moisture, etc.), be sure to check the filter gauge often for filter change notice.

## Lubrication Recommendations

Component	Location	Recommendation
Engine	Crankcase	Apply Manufacturer's Recommendations
Hydraulic System Below -5°F -5°F to 90°F Above 90°F	Reservoir	Petro-Canada Arctic MV 15 (ISO 22) Petro-Canada HYDREX 32 (ISO 32) Petro-Canada HYDREX 46 (ISO 46)
Open Gears	Hand	Precision XL3 Moly EP 2 (NLGI 2 grease with moly)
Bearings, grease (including turntable bearing inner race)	Gun	Precision XL EP 2 (NLGI 2)
Worm Drive Gearbox	Gearbox	Precision Synthetic EP 00 (NLGI 00)
Planetary Gearbox (including winch)	Gearbox	Traxon Synthetic 75W-90 (API GL-5)
Wear Pad Lubrication	Spray	Gearshield NC
Compressor Fluids		
Reciprocating Single Stage Reciprocating Double Stage	Crankcase Crankcase	Compro 100 (ISO 100) Compro 100 (ISO 100)
Screw -15°F to 86°F -23°F to 100°F 32°F to 113°F	Crankcase	Compro XL-S 32 (ISO 32) Compro XL-S 46 (ISO46) Compro XL-S 68 (ISO68)

## Greasing the Crane

Lubricate all grease gun points with  
**Extreme Pressure Grease - Stellar P/N: 22059.**



**Holding Valve Inspection Procedure**

The cylinders are equipped with holding valves that prevent sudden movement of the cylinder rods in the event of a hydraulic hose or hydraulic component failure. The valve is checked in the following manner:

1. Identify the cylinder in question.
2. Identify the holding valves and the cylinder direction in question.
  - a. Cylinder Extend.
  - b. Cylinder Retract.
3. Place the machine so that the cylinder will be located in the appropriate testing position.
4. Pick the load (Do not exceed capacity, rated or stability).
5. Disengage hydraulics.
6. Operate crane functions.
  - A. If the cylinder creeps (lowering the load), replace the holding valve.
  - B. If the cylinder does not creep (load stays suspended), the valve is operational.

**Gear-Bearing Bolt Maintenance**

Anytime a gear-bearing bolt is removed, it must be replaced with a new bolt of the identical grade and size. Once a bolt has been torqued to 75% of its proof load and then removed, the torque coefficient may no longer be the same as when the bolt was new thus giving indeterminate damp loads after torquing.

**Warning!**  
**Failure to replace gear-bearing bolts may result in bolt failure due to metal fatigue causing serious injury or even death.**

**Torque Data Chart**

Note: For Crane Tie Down Rods, see Chapter 6: Installation Overview.

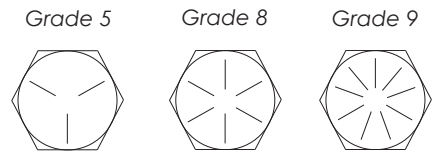

Size (DIA-TPI)	Bolt DIA (Inches)	Plain (Ft-Lb)	Plated (Ft-Lb)	Plain (Ft-Lb)	Plated (Ft-Lb)	Plated (Ft-Lb)
5/16-18	0.3125	17	13	25	18	22
3/8-16	0.3750	31	23	44	33	39
7/16-14	0.4375	49	37	70	52	63
1/2-13	0.5000	75	57	105	80	96
9/16-12	0.5625	110	82	155	115	139
5/8-11	0.6250	150	115	220	160	192
3/4-10	0.7500	265	200	375	280	340
7/8-9	0.8750	395	295	605	455	549
1-8	1.000	590	445	910	680	823
1 1/8-7	1.1250	795	595	1290	965	1167
1 1/4-7	1.2500	1120	840	1815	1360	1646
1 3/8-6	1.3750	1470	110	2380	1780	2158
1 1/2-6	1.500	1950	1460	3160	2370	2865

When using the torque data in the charts above, the following rules should be observed.

1. Bolt manufacturer's particular specifications should be consulted when provided.
2. Flat washers of equal strength must be used.
3. All torque measurements are given in foot-pounds. To convert to inch-pounds, multiply by 12.
4. Torque values specified are for bolts with residual oils or no special lubricants applied. If special lubricants of high stress ability, such as Never-Seez compound graphite and oil, molybdenum disulphite, colloidal copper or white lead are applied, multiply the torque values in the charts by the factor .90. The use of Loctite does not affect the torque values listed above.
5. Torque values for socket-head capscrews are the same as for Grade 8 capscrews.

# Inspection Checklist

Use of this checklist is subject to terms of the Stellar Warranty information. Additional copies of this checklist can be obtained by contacting Stellar Customer Service at (800) 321-3741.

Type of Inspection (check one)

- Daily (if deficiency found)     Quarterly  
 Monthly                                     Annual

Owner/Company:

Contact Person:

Crane Make/Model:

Crane Serial:

Date Inspected:

Hour Meter Reading:

Inspected by: (print)

Signature of Inspector:

## Type of Inspection Information

Daily and monthly inspections are to be performed by a "designated" person, who has been selected by the employer or the employer's representative as being competent to perform specific duties.

Quarterly and annual inspections are to be performed by a "qualified" person who, by possession of a recognized degree in an applicable field or certificate of professional standing, or who, by extensive knowledge, training and experience has successfully demonstrated the ability to solve or resolve problems related to the subject matter and work.

One hour of normal crane operation assumes 20 complete cycles per hour. If operation exceeds 20 cycles per hour, inspection frequency should be increased accordingly.

Consult the Stellar Owner's Manual for additional inspection items.

Before inspecting and operating the crane, make certain that the crane is set up away from power lines and leveled with outriggers fully extended.

**Daily (D):** Before each day of operation, those items with a (D) must be inspected. This inspection need not be recorded unless a deficiency is found.

**Monthly (M):** Monthly inspections or 100 hours of normal operation (which ever comes first) includes all daily and monthly inspection items plus items designated with a (Q). This inspection must be recorded.

**Quarterly (Q):** Every three months or 300 hours of normal operation (which ever comes first) includes all daily and monthly inspection items plus items designated with an (M). This inspection must be recorded.

**Annual (A):** Each year or 1200 hours of normal operation (which ever comes first) includes all items on this form which encompasses daily, monthly, and quarterly inspections plus those items designated by (A). this inspection must be recorded.



## Monthly Inspection

Frequency	Key	Inspection Description	Status
M	Daily	All Daily Inspections.	
M	Cylinders	Visual inspection of cylinders for leakage at rod, fittings, & welds. Damage to rod & case.	
M	Valves	Holding valves for proper operation.	
M	Valves	Control valve for leaks at fittings & between sections.	
M	Valves	Control valve linkages for wear, smoothness of operation & tightness of fasteners. Relief valve for proper pressure settings.	
M	General	Bent, broken or significantly rusted/corroded parts.	
M	Electrical	Electrical systems for presence of dirt, moisture & frayed wires.	
M	Structure	All structural members for damage.	
M	Welds	All welds for breaks & cracks.	
M	Pins	All pins for proper installation & condition.	
M	Hardware	All bolts, fasteners & retaining rings for tightness, wear & corrosion.	
M	Wear Pads	Condition of wear pads.	
M	Pump & Motor	Hydraulic pumps & motors for leakage at fittings, seals & between sections. Check tightness of mounting bolts.	
M	PTO	Transmission/PTO for leakage, abnormal vibration & noise, alignment & mounting bolt torque.	
M	Hyd Fluid	Quality of hydraulic fluid and for presence of water.	
M	Hyd Lines	Hoses & tubes for leakage, abrasion damage, blistering, cracking, deterioration, fitting leakage, & secured properly.	
M	Hook	Load hook for abnormal throat distance, twist, wear, & cracks.	
M	Rope	Condition of load line.	
M	Manual	Presence of operator's manuals with the unit.	
M	Chassis	Tire wear and air pressure.	
M	Chassis	Working backup alarm.	
M	Station	Fire extinguisher at cab or machinery housing.	

## Quarterly Inspection

Frequency	Key	Inspection Description	Status
Q	Daily	All daily inspections.	
Q	Monthly	All monthly inspections.	
Q	Rotation Sys	Rotation bearing for proper torque of all mounting bolts.	
Q	Hardware	Base mounting bolts for proper torque.	
Q	Structure	All structural members for deformation, cracks, & corrosion.	
		Base	
		Outrigger beams & legs	
		Mast	
		Inner boom	
		Outer boom	
		Extension(s)	
		Jib boom	
		Jib extension(s)	
		Other	
		Other	
Q	Hardware	Pins, bearings, shafts, gears, rollers, & locking devices for wear, cracks, corrosion, & distortion.	
		Inner boom pivot pin(s) & retainer(s)	
		Outer boom pivot pin(s) & retainer(s)	
		Inner boom cylinder pin(s) & retainer(s)	
		Outer boom cylinder pin(s) & retainer(s)	
		Extension cylinder pin(s) & retainer(s)	
		Jib boom pin(s) & retainer(s)	
		Jib cylinder pin(s) & retainer(s)	
		Jib extension cylinder pin(s) & retainer(s)	
		Boom tip attachments	
		Other	
		Other	



## Quarterly Inspection Continued...

Frequency	Key	Inspection Description	Status
Q	Hyd Lines	Hoses, fittings, & tubing for proper routing, leakage, blistering, deformation, & excessive abrasion.	
		Pressure line(s) from pump to control valve	
		Return line(s) from control valve to reservoir	
		Suction line(s) from reservoir to pump	
		Pressure line(s) from control valve to each function	
		Load holding valve pipe(s) and hose(s)	
		Other	
Q	Pumps&Motors	Pumps and motors for loose bolts/fasteners, leaks, noise, vibration, loss of performance, heating and excess pressure.	
		Winch motor(s)	
		Rotation motor(s)	
		Other	
Q	Valves	Hydraulic valves for cracks, spool return to neutral, sticking spools, relief valve failure.	
		Main control valve	
		Load holding valve(s)	
		Outrigger or auxiliary control valve(s)	
		Other	
Q	Cylinders	Hydraulic cylinders for drifting & leakage. Rods for nicks, scores, & dents. Castor damage. Case & rod ends for damage & abnormal wear.	
		Outrigger cylinder(s)	
		Inner boom cylinder(s)	
		Outer boom cylinder(s)	
		Extension cylinder(s)	
		Rotation cylinder(s)	
		Jib lift cylinder(s)	
		Jib extension cylinder(s)	
		Other	
Q	Winch	Winch, sheaves, & drums for damage, abnormal wear, abrasion, & other irregularities.	
Q	Hyd Filter	Hydraulic filters for replacement per maintenance schedule.	







# Chapter 4 - Specifications

## Model 28000 Crane SPECIFICATION SHEET

Crane Rating:	280,000 ft-lbs (38.71 ton meters)
Standard Boom Length:	13' 2" (4.01 m) from CL of Crane
Boom Extension:	Hydraulic 37" (94.0 cm)
Maximum Horizontal Reach:	16' 3" (4.95 m) from CL of Crane
Maximum Vertical Lift: (From Truck Frame)	25' (7.62 m)
Cylinder Specifications	
Inner Lift Cylinder:	9" (22.9 cm) bore with integral pilot operated counterbalance valves.
Outer Lift Cylinder:	7" (17.8 cm) bore with integral pilot operated counterbalance valves.
Extension Cylinder:	6" (15.2 cm) bore with integral pilot operated counterbalance valves.
Rotation: (planetary gear with pinion)	315 degree power
Lifting Capacities: (From CL of Truck)	28,000 lbs @ 10' (12,700 kg @ 3.05 m) 17,200 lbs @ 16' 3" (7,800 kg @ 4.95 m)
Power Supply Required:	PTO & Pump (16 gpm @ 4,200 psi) (60 lpm @ 290 bars)
Controls:	Fully Proportional Paddle Controls for all functions.
Stowed Height: (Above Truck Frame)	114" (289.6 cm)
Mounting Space Required:	48" (121.9 cm)
Approximate Shipping Weight:	13,000 lbs (5,895 kg)



# Capacity Chart - Decal PN 16055

## CAPACITY CHART

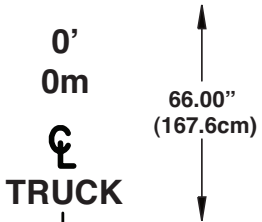
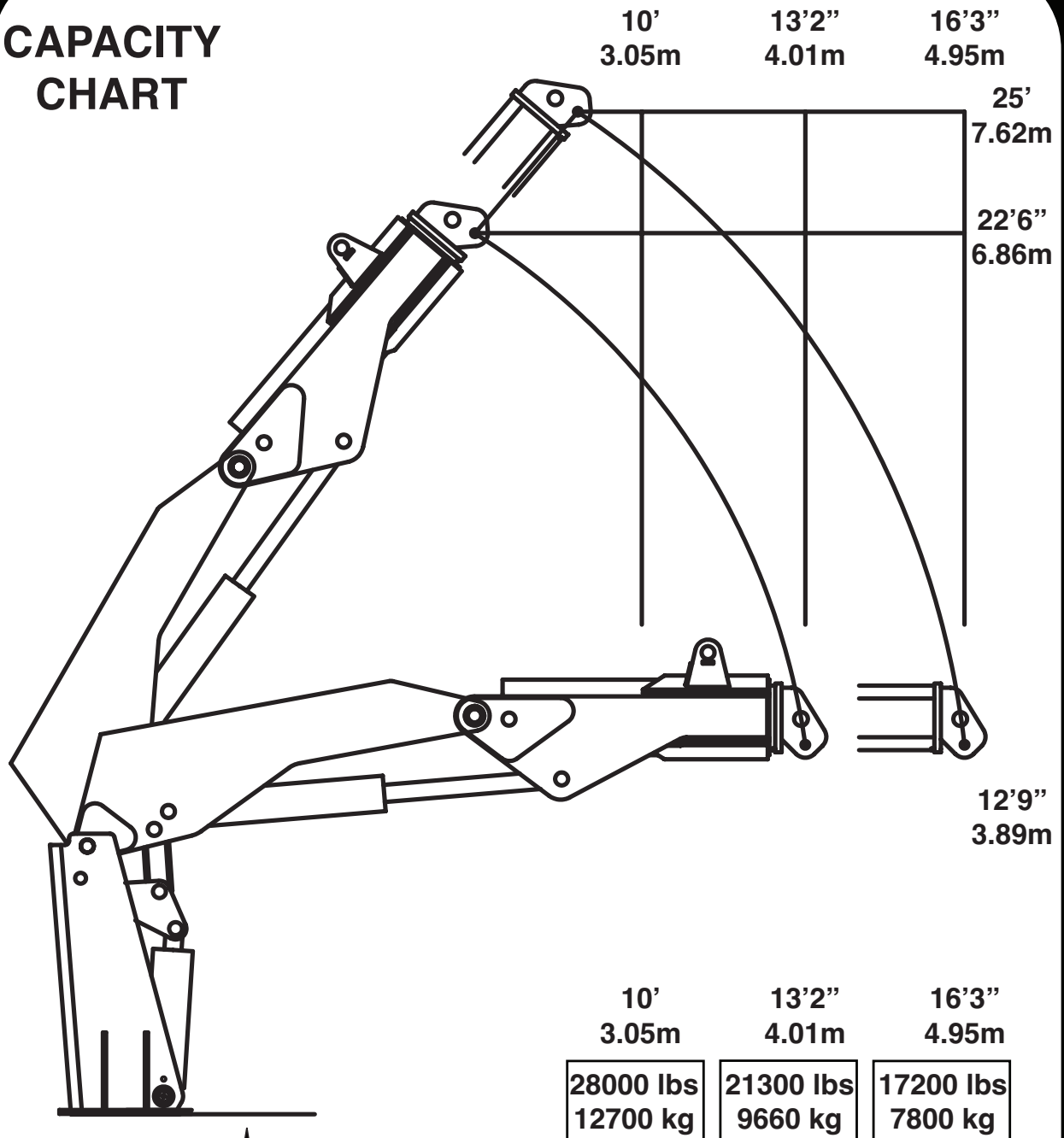

GROUND

190 STATE STREET GARNER, IA 50438  
 PHONE: (800) 321-3741 FAX: (641) 923-2812

0'  
0m

16055

# Chapter 5 - Decals

## Decals of Note

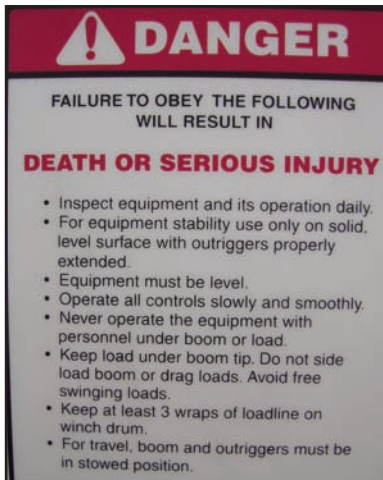

### Operation Hazard Decal

**Function:** To inform the operator of the need for proper training, familiarity with safe operating procedures, and the possible consequences of operation without training.

PN: C4544

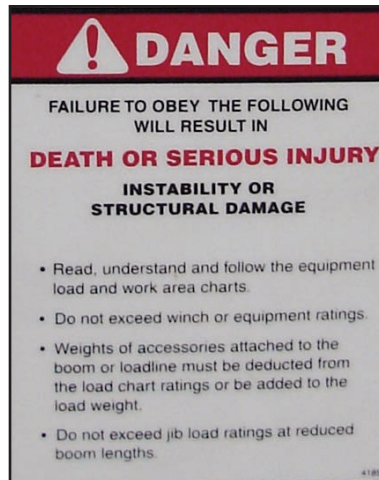

### Operation Hazard Decal

**Function:** To inform the operator of the hazard associated with overloading the crane, the possible consequences should the hazard occur, and how to avoid the hazard.

PN: 4189

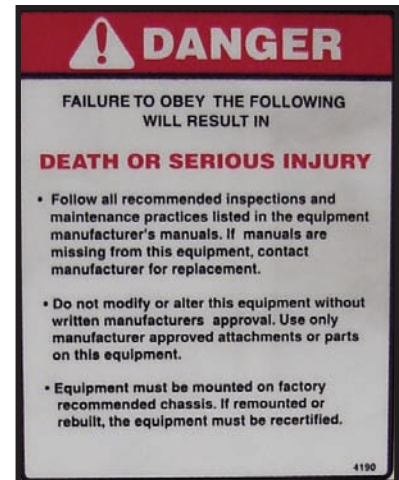

### Operation Hazard Decal

**Function:** To inform the operator and other personnel in the work area of the hazard associated with improper maintenance and unauthorized modifications, the possible consequences should the hazard occur, and how to avoid the hazard.

PN: 4190

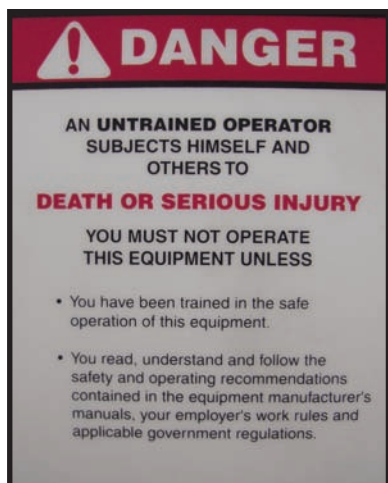

### Operation Hazard Decal

**Function:** To inform the operator of the need for proper training, familiarity with safe operating procedures and , the possible consequences without training.

PN: C4540



### Foot Crush Hazard Decal

**Function:** To inform the operator and other personnel in the work area of the hazard associated with the operation of the outriggers, the possible consequences should the hazard occur, and how to avoid the hazard. PN: C4795

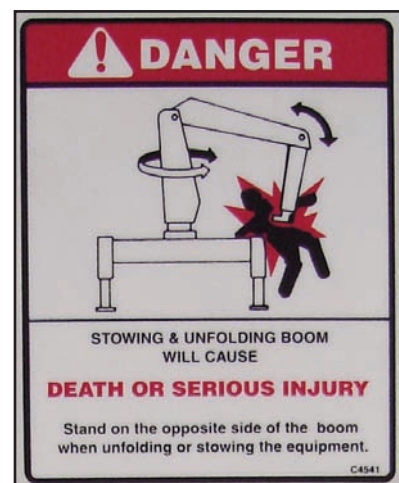

### Moving Boom Hazard Decal

**Function:** To inform the operator and other personnel in the work area of the hazard associated with a moving boom, especially while stowing and unfolding the crane, the possible consequences should the hazard occur, and how to avoid the hazard. PN: C4541

## Decals of Note Continued...



**Electrocution Hazard Decal**

**Function:** To inform the operator and other personnel in the work area of the hazard associated with contact or proximity to electrical lines, the possible consequences should the hazard occur and how to avoid the hazard. PN: C1179



**Moving Outrigger Hazard Decal**

**Function:** To inform the operator of the hazard associated with outrigger operation, the possible consequences should the hazard occur, and how to avoid the hazard. PN: C5918



**Tire Man Hazard Decal**

**Function:** To inform the operator and other personnel in the work area of the hazard associated with improper use of the Tire Man, the possible consequences should the misuse occur and how to avoid these hazard.

PN: 16732

# Decal Kit - PN 16658

The following chapter highlights many decals of note on your Stellar 28000 and possibly the TM14160. For a complete list of decals, please refer to the Decal Placement drawing below. **Remember: Decals are considered safety equipment. They must be maintained, as would other safety devices. Do not remove any decals. Replace any decals that are missing, damaged, or not legible.**

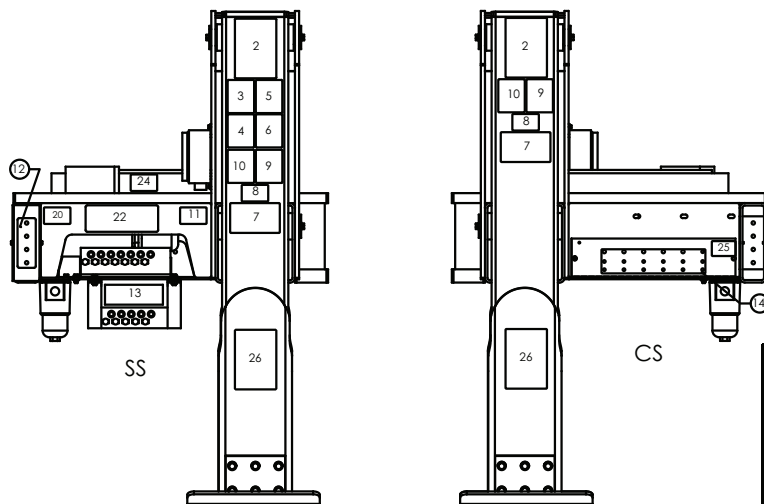
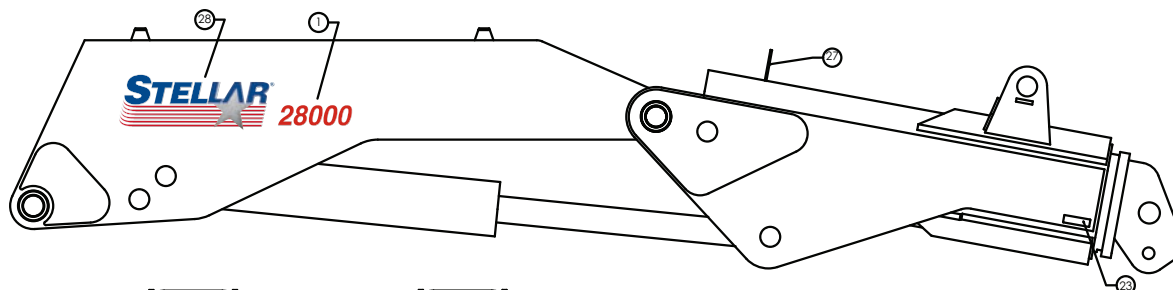

THESE DECALS NOT SHOWN  
(USE WITH BODY PACKAGE)

## PN 16658

28	54589	DECAL STELLAR LOGO 8.00x22.25	2
27	47404	DECAL COUPLERS 23000	1
26	16732	DECAL- TIRE MAN OVERLOAD POSITION	2
25	22619	DECAL-GEARBOX OIL LEVEL	1
24	22618	DECAL-GREASE WORM DRIVE	1
23	16973	DECAL-STELLAR ATTACHMENTS	2
22	43469	DECAL-VB CONTROL 28000	1
21	15172	DECAL ASME/ANSI B30.22/B30.5	1
20	16657	DECAL-CONTROL HANDLE 28,000	1
19	C5910	DECAL STELLAR LOGO 4.00X9.50	1
18	C5911	DECAL-STELLAR LOGO 2.00X4.50	2
17	8843	DECAL-EXPLODING TANK	1
16	8998	DECAL-AIR DRAIN	1
15	C4545	DECAL-DANGER ELECTROCUTION	4
14	36248	DECAL SWITCH PANEL 28000 CRANE	1
13	43470	DECAL-OUTRIGGER 28,000	1
12	16620	DECAL-SWITCH PLATE 28,000	1
11	4214	DECAL-SERVICE	1
10	C4795	DECAL-DANGER FOOT	2
09	C4541	DECAL-WARNING	2
08	C5918	DECAL-CAUTION STAND CLEAR	2
07	C1179	DECAL-DANGER ELECTROCUTION HORTL	2
06	4190	DECAL-DANGER OPERATION CONDITION	1
05	C4544	DECAL-CAUTION	1
04	4189	DECAL-DANGER OPERATION RESTRICTION	1
03	C4540	DECAL-DANGER	1
02	16055	DECAL-CAPACITY	2
01	54597	DECAL- 28000 IDENTIFICATION	2
ITEM	PART No.	DESCRIPTION	QTY





# Chapter 6 - Installation

## Notice: Read this Page Before Installation of the Crane

### General Installation

This chapter is designed to serve as a general guide for the installation of a Stellar 28000 Articulating Crane on a Stellar Service Body. Each installation is considered unique so certain portions of this chapter may or may not apply to your direct application. If a question should arise during the installation process, please contact Stellar Customer Service at (800) 321 3741.

This crane is designed for use with a Stellar Service Body installed on a vehicle that meets the minimum chassis requirements of the crane. Check with Stellar Industries before installing this crane on a body other than a Stellar Service Body.

**WARNING!**  
**The use of this crane on a body not capable of handling the loads imposed on it may result in serious injury or death.**

**Notice:**  
 PTO and Pump installation instructions are provided by the corresponding manufacturers. For more information on which PTO and Pump fit your application, please contact your local Stellar Distributor or Stellar Customer Service.

### Installation Notice

According to Federal Law (49 cfr part 571), each final-stage manufacturer shall complete the vehicle in such a manner that it conforms to the standards in effect on the date of manufacture of the incomplete vehicle, the date of final completion, or a date between those two dates. This requirement shall, however, be superseded by any conflicting provisions of a standard that applies by its terms to vehicles manufactured in two or more stages.

Therefore, the installer of Stellar cranes and bodies is considered one of the manufacturers of the vehicle. As such a manufacturer, the installer is responsible for compliance with all applicable federal and state regulations. They are required to certify that the vehicle is in compliance with the Federal Motor Vehicle Safety Standards and other regulations issued under the National Traffic and Motor Vehicle Safety Act.

Please reference the Code of Federal Regulations, title 49 - Transportation, Volume 5 (400-999), for further information, or visit <http://www.gpoaccess.gov/nara/index.html> for the full text of Code of Federal Regulations.

## Installation Overview

### For more detail, please contact Stellar Customer Service

1. Relocate any obstructions on the frame that will be in the way of mounting the crane.
2. Measure the inside of the frame rails and cut the frame support to this length. Ensure that the frame supports have a tight fit between the frame rails.
3. Set the crane on the chassis and allow a minimum of 2" from the cab.
4. Install the crane tie downs. Start at one corner and tighten both tie downs to 200 ft-lbs. Move to the diagonal set and tighten to 200 ft-lbs. Tighten the remaining 2 corners. Continue this pattern at 200 ft-lb increments until 650-700 ft-lbs is achieved. Be sure the mounting block stays perpendicular to the frame rail as they are tightened down.
5. Connect the pressure and return lines per the hydraulic kit.
6. Connect the (+12V) power and ground wires.
7. Check the reservoir for oil and fill if necessary.
8. Operate the crane for several cycles.

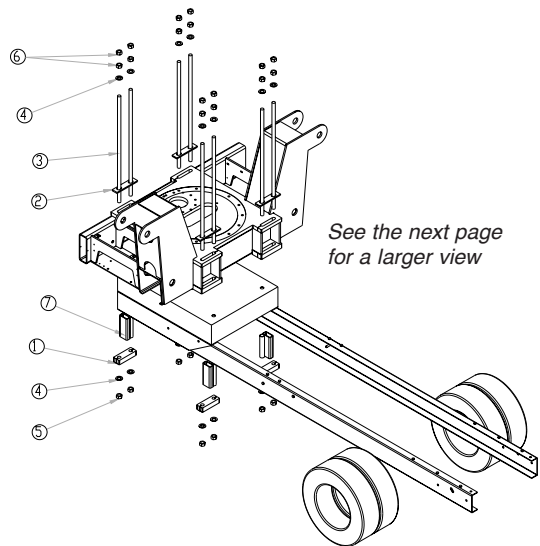

PN 16659

ITEM	PART	DESCRIPTION	QTY.	ITEM	PART	DESCRIPTION	QTY.
1	8054	MTG BLOCK 15000	4	5	8834	NUT 1.25-7 HHGR8 TOP LOCKING	8
2	11677	PLATE MOUNTING 23000	4	6	8978	NUT 1.25-7 HHGR8	16
3	14486	TIE DOWN ROD	8	7	8202	FRAME SUPPORT 15000 CRANE	4
4	9189	WASHER 1.25 SAE FLAT YELLOW GR8	16				

# Mounting Kit Drawing 16659

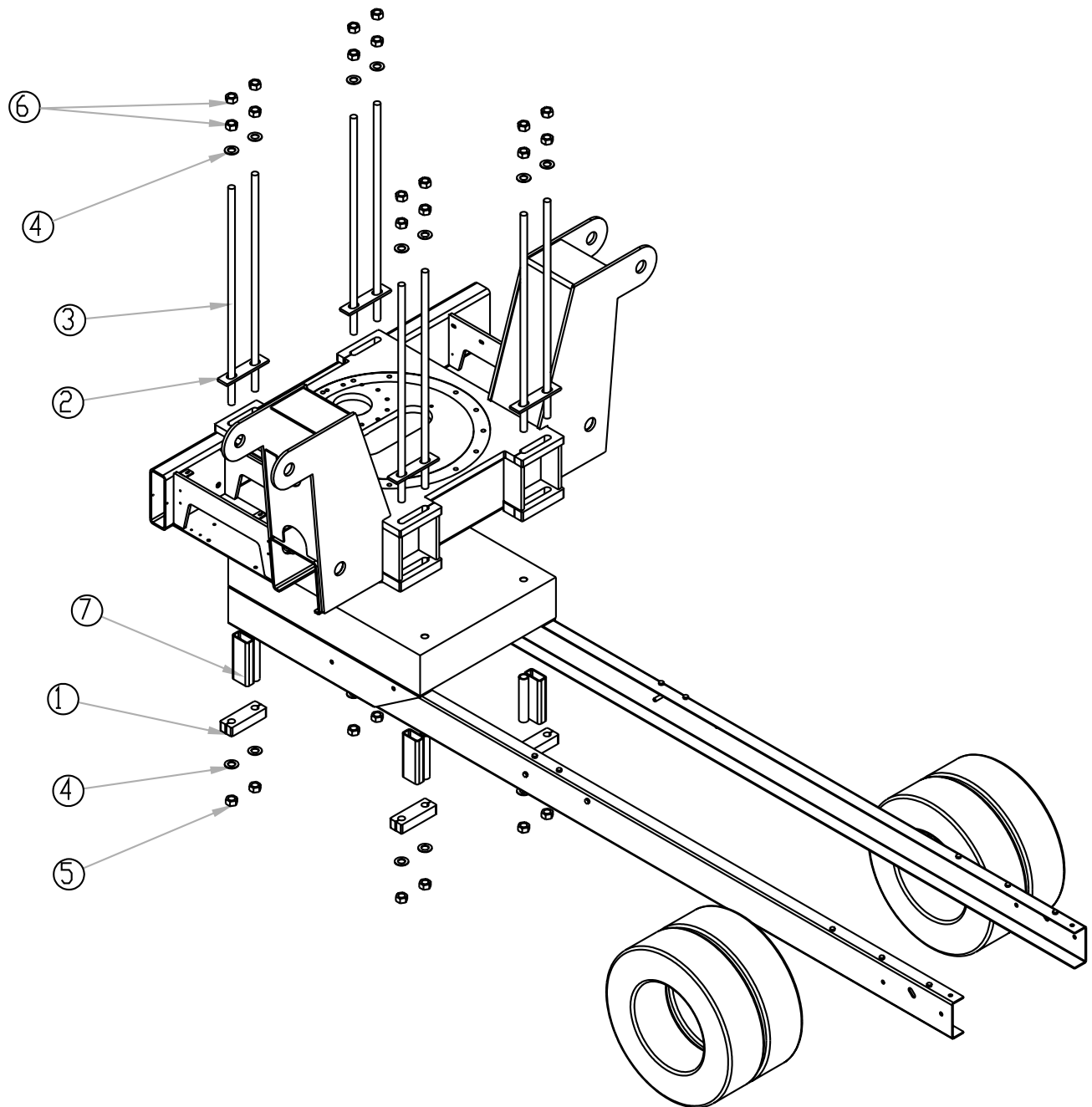

**PN 16659**

ITEM	PART	DESCRIPTION	QTY.	ITEM	PART	DESCRIPTION	QTY.
1	8054	MTG BLOCK 15000	4	5	8834	NUT 1.25-7 HHGR8 TOP LOCKING	8
2	11677	PLATE MOUNTING 23000	4	6	8978	NUT 1.25-7 HHGR8	16
3	14498	TIE DOWN ROD	8	7	8202	FRAME SUPPORT 15000 CRANE	4
4	9180	WASHER 1.25 SAE FLAT YELLOW GR8	16				



# Chapter 7 - Assembly Drawings

## Base Assembly - PN 47880

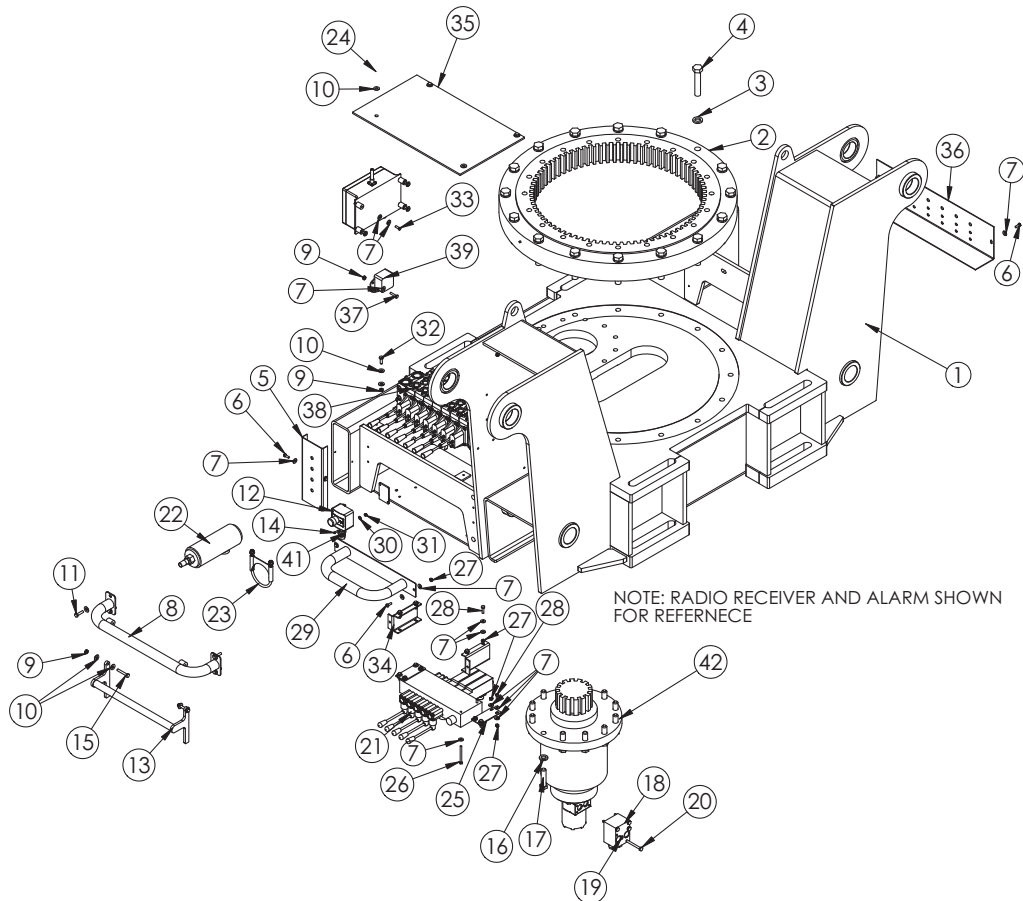

### PN 47880

ITEM	PART	DESCRIPTION	Base
1	48686	BASE 28000	1
2	18471	TURNTABLE BEARING 23000	1
3	18041	WASHER 0.88 SAE FLAT YELLOW GR9	16
4	17962	CAP SCR 0.88-9X4.50 HHGR9 ZY	16
5	41336PC	PLATE SWITCH MTG 23000	1
6	0479	CAP SCR 0.25-20X0.75 HHGR5	6
7	0340	WASHER 0.25 FLAT	42
8	41084PC	GUARD VB 23000	1
9	0342	NUT 0.31-18 HH NYLOC	7
10	0343	WASHER 0.31 USS FLAT ZINC	18
11	0485	CAP SCR 0.31-18X1.25 HHGR5	4
12	22921	E-STOP PANIC BAR 28000	1
13	41082	BAR PANIC 23000	1
14	22183	CAP SCR #8-32X0.75 BTNHD SS	2
15	0488	CAP SCR 0.31-18X2.00 HHGR5	2
16	C6219	WASHER 0.75 SAE FLAT YELLOW GR8	12
17	C1028	CAP SCR 0.75-10X3.00 HHGR8 ZY	12
18	22935	VALVE BLOCK CBCA-LAN-XTS	1
19	5591	WASHER 0.31 SAE FLAT YELLOW GR8	4
20	C0930	CAP SCR 0.31-18X3.00 HHGR5	4
21	40827	VB 5 SECT HYDRO CONTROL HC-D3M/5	1
22	41338	FILTER ZINGA 23000	1
23	41339	CLAMP ZINGA FILTER 23000	1
24	0420	CAP SCR 0.31-18X0.75 HHGR5	4
25	44079PC	BRACKET VB MNT 23000	2
26	0482	CAP SCR 0.25-20 X 3.00 HHGR5	4
27	0333	NUT 0.25-20 HHGR5 NYLOC	15
28	0480	CAP SCR 0.25-20X1.00 HHGR5	8
29	44511	GUARD OUTRIG VB 23000	1
30	22185	WASHER 0.19 FLAT SS	2
31	22186	NUT #8-32 HH NYLOC SS	2
32	C0922	CAP SCR 0.31-18X1.00 HHGR5	3
33	47425	CAP SCR 6MMX20MM HH CLASS 8.8	4
34	44078PC	BRACKET VB MNT BASE 23000	2
35	41337PC	PLATE COVER 23000	1
36	36243PC	PLATE SWITCH MTG 28000 CRANE	1
37	0437	CAP SCR 0.25-20X1.25 HHGR5	2
38	42802	VB 7 SECT DANFOSS PVG32	1
41	12869	STRAIN RELIEF .50 NPT .24-.47 CABLE	1
42	60505	GEAR BOX W/MOTOR 23/28000	1

# Mast Assembly - PN 18073

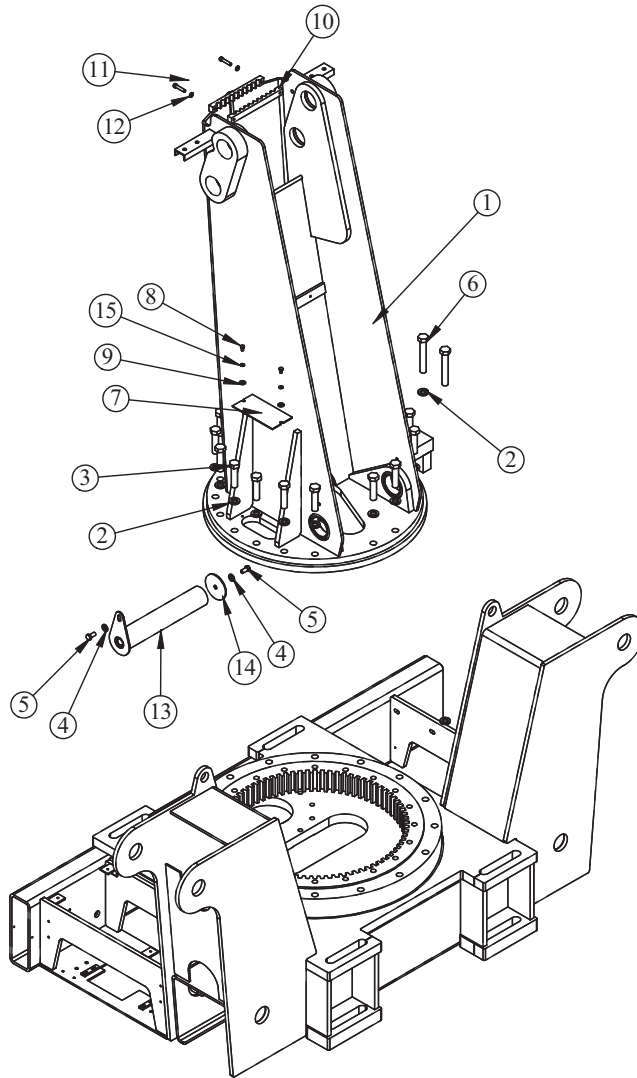

## PN 18073

ITEM	PART	DESCRIPTION	QTY.
1	15403	MAST 28000	1
2	18041	WASHER 0.88 SAE FLAT YELLOW GR9	18
3	17963	CAP SCR 0.88-9X3.50 HHGR9 ZY	16
4	D0790	WASHER 0.50 FLAT GR8	2
5	10172	CAP SCR 0.50-13X1.00 HHGR8 ZY	2
6	17964	CAP SCR 0.88-9X5.50 HHGR8	2
7	11297	PLATE INSPECTION MAST 23000	1
8	0484	CAP SCR 0.31-18 X 0.50 HHGR5	2
9	0343	WASHER 0.31 USS FLAT ZINC	2
10	17133	HOSE CLAMP 28000	1
11	11882	CAP SCR 0.38-16X1.75 SH ZC	2
12	0523	WASHER 0.38 LOCK	2
13	15755ZP	PIN TEAR DROP 3.00X16.13	1
14	13315	PIN CAP 0.56X4.00X0.19	1
15	0522	WASHER 0.31 LOCK	2

# Main Boom Assembly - PN 55106

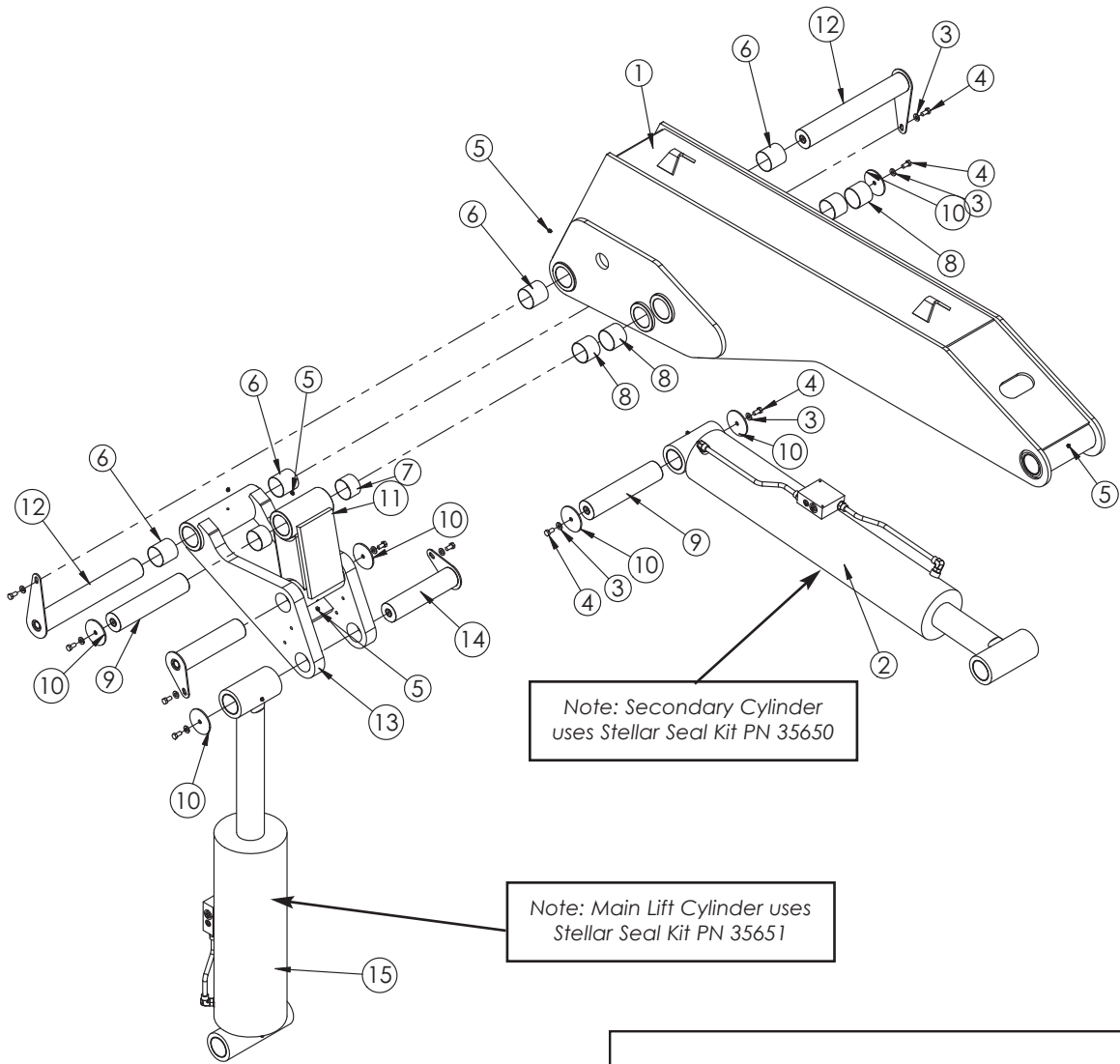

## PN 55106

ITEM	PART	DESCRIPTION	QTY.
1	55103	INNER BOOM 28000 REVISED	1
2	50628	CYLINDER ASM 7.00X38.25	1
3	D0790	WASHER 0.50 SAE FLAT YELLOW GR8	10
4	10172	CAP SCR 0.50-13X1.00 HHGR8	10
5	c1592	ZERK 1/8 NPT STRAIGHT	5
6	2227	BUSHING 48DXR48 GARLOCK	6
7	0865	BUSHING 48DXR32 GARLOCK	4
8	54374	BUSHING COMPOSITE MRP 3.00X2.50	4
9	41063ZP	PIN 3.00X14.00 D&T	2
10	13315	PIN CAP 0.56X4.00X0.19	6
11	15497	LINK WLDMT 28000 MAIN	1
12	31056ZP	PIN TEAR DROP 3.00X20.13	2
13	15495	LINK MAIN 28000	1
14	15763ZP	TEAR DROP PIN 3.00X12.63	2
15	20694	CYLINDER ASM 28000 MAST	1

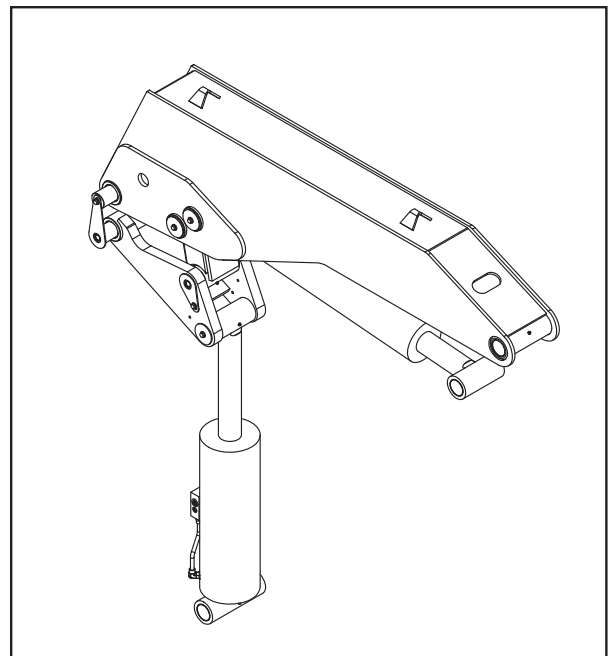

# Main Boom Cylinder Assembly - PN 20694

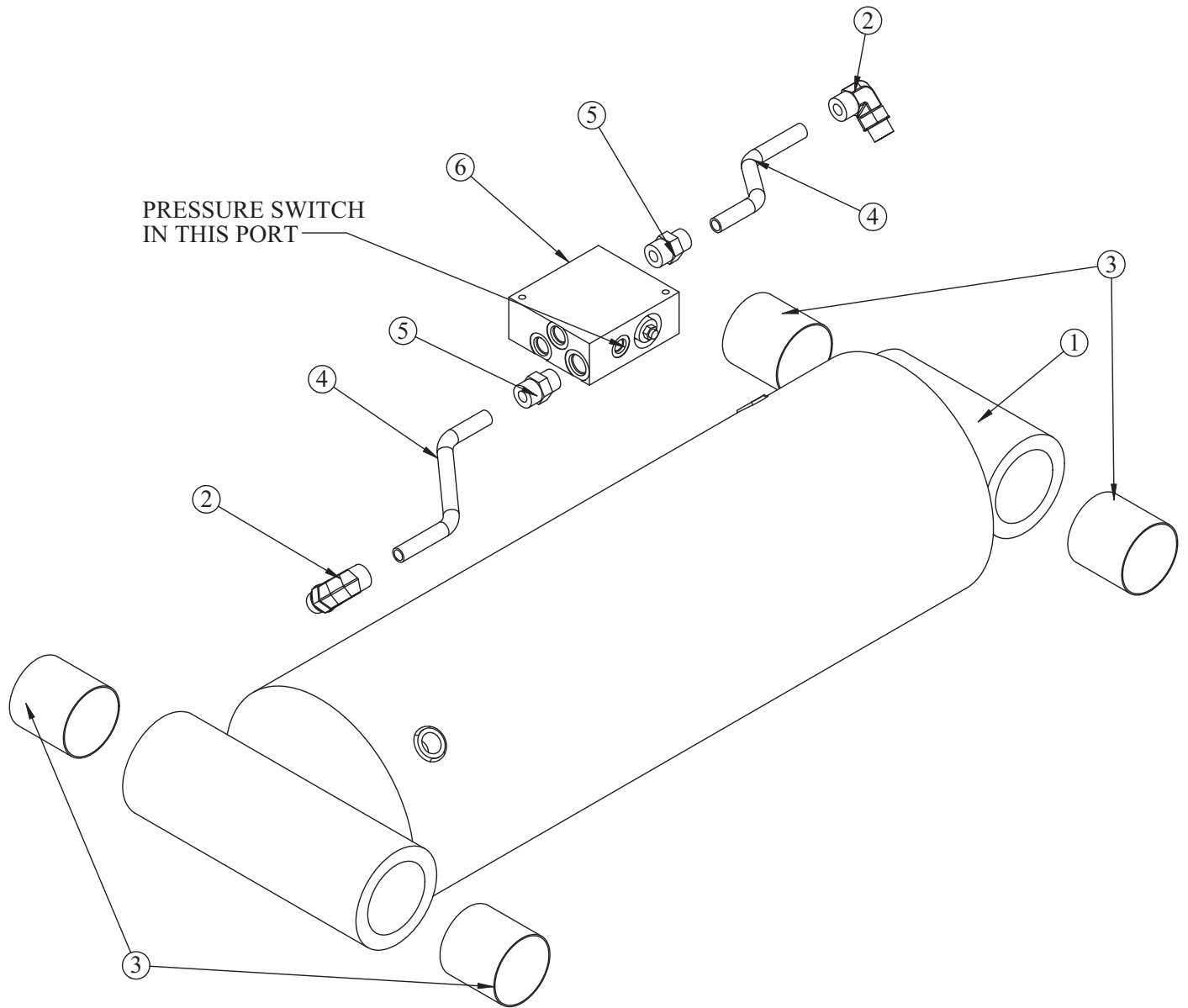

## PN 20694

ITEM NO.	PART NO.	DESCRIPTION	QTY
1	15598	CYLINDER 9.00x4.00x21.81	1
2	16153	FTG ADAPT 10-C5OLO-S	2
3	2227	BUSHING 48DXR48 GARLOCK	4
4	16157	TUBE ASM 0.63X7.88 YZ	2
5	16152	FTG ADAPT 10-F5OLO-S	2
6	15995	MANIFOLD ASM DUAL T2A 5000PSI	1

# Extension Boom Assembly - PN 55108

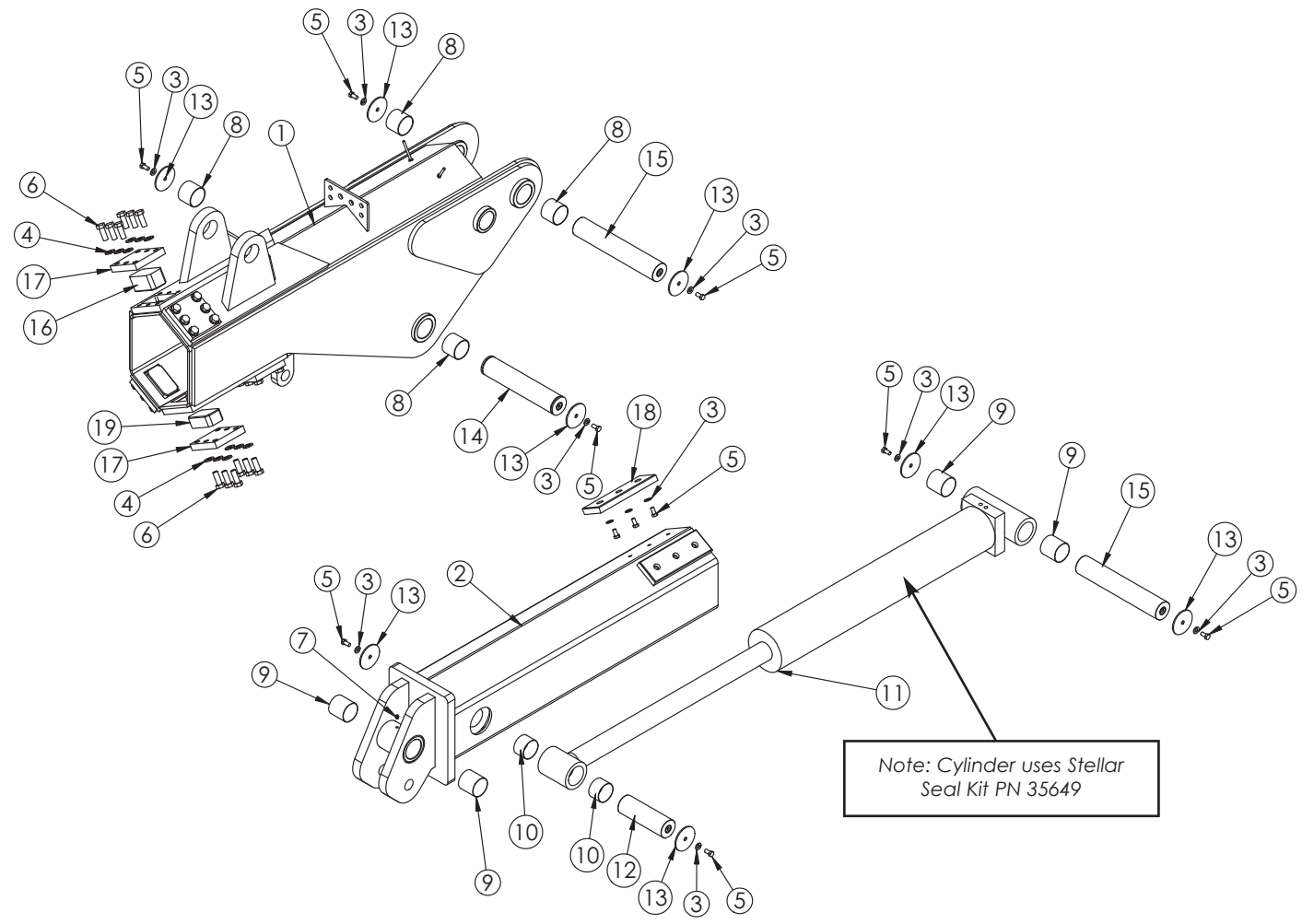

## PN 55108

ITEM	PART	DESCRIPTION	QTY.
1	55107	OUTER BOOM 28000 REVISED	1
2	15388	EXT BOOM 28000	1
3	D0790	WASHER 0.50 SAE FLAT YELLOW GR8	14
4	C6219	WASHER 0.75 SAE FLAT YELLOW GR8	36
5	10172	CAP SCR 0.50-13X1.00 HHGR8	14
6	4543	CAP SCR 0.75-10X2.00 HHGR8	36
7	c1592	ZERK 1/8 NPT STRAIGHT	1
8	54374	BUSHING COMPOSITE MRP 3.00X2.50	4
9	2227	BUSHING 48DXR48 GARLOCK	4
10	0865	BUSHING 48DXR32 GARLOCK	2
11	15608	CYLINDER 6.00x37.00	1
12	15769ZP	PIN 3.00X9.13 D&T	1
13	13315	PIN CAP 0.56X4.00X0.19	8
14	26973ZP	PIN 3.00X15.00 SR/D&T	1
15	55109ZP	PIN 3.00X16.88 D&T	2
16	15778	WEAR PAD 3.00X5.00X2.44	2
17	15609PC	PLATE WEAR PAD COVER 28000	6
18	15601	WEAR PAD 1.00X4.00X12.00	2
19	15779	WEAR PAD 3.00X5.00X1.75	4

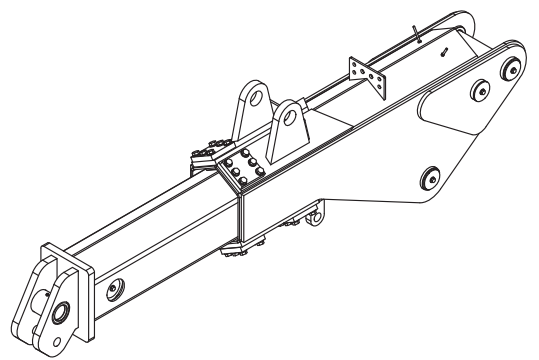

# Extension Boom Cylinder Assembly - PN 50628

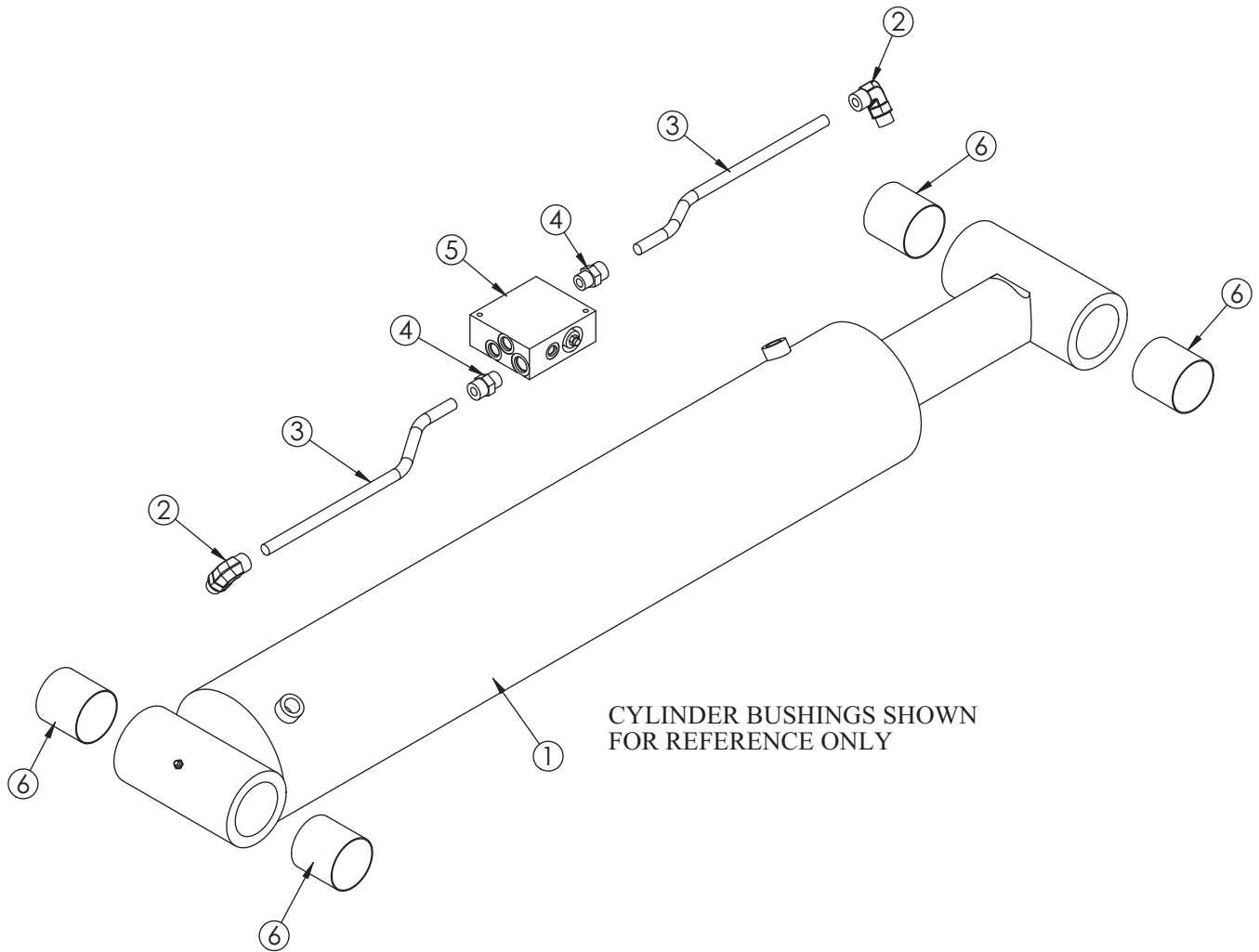

## PN 50628

ITEM	PART	DESCRIPTION	QTY.
1	15604	CYLINDER 7.00X38.25	1
2	16153	FTG ADAPT 10-C5OLO-S	2
3	16158	TUBE ASM 0.63X16.09	2
4	16152	FTG ADAPT 10-F5OLO-S	2
5	15995	MANIFOLD ASM DUAL T2A 5000PSI	1
6	2227	BUSHING 48DXR48 GARLOCK	4

# Outrigger Assembly - PN 48689

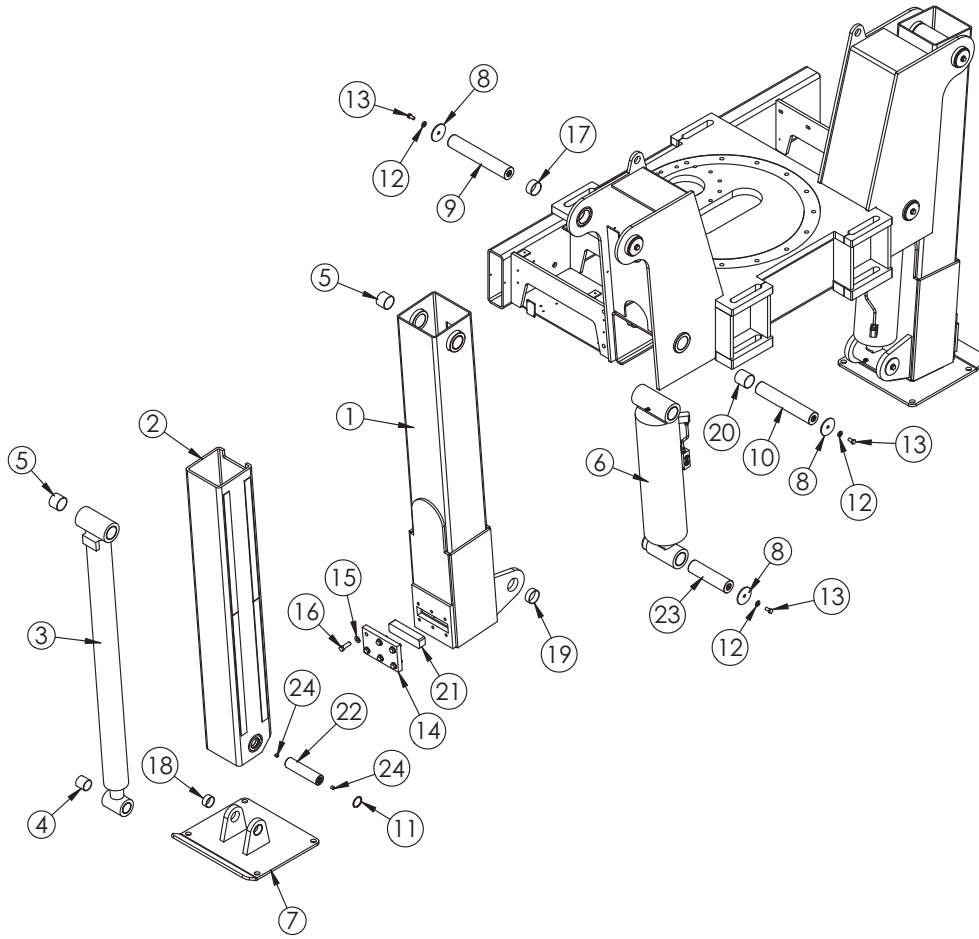

## PN 48689

ITEM	PART	DESCRIPTION	QTY.
1	40450	OUTRIGGER 23000	2
2	15502	OUTRIGGER LEG 28000	2
3	9994	CYLINDER 4.00X50.00	2
4	4381	BUSHING 32DXR32 2.00X2.00 GARLOCK	4
5	0635	BUSHING 40DXR32 GARLOCK	8
6	48383	CYLINDER ASM 48384	2
7	40837	OUTRIGGER PAD 23000 96IN	2
8	8377	PIN CAP 0.56X3.50X0.19	12
9	40459ZP	PIN 2.50X14.88 D&T	2
10	48385ZP	PIN 2.50X14.00 D&T	2
11	2257	SNAP RING INSIDE 2.00	4
12	D0790	WASHER 0.50 FLAT GR8	12
13	10172	CAP SCR 0.50-13X1.00 HHGR8 ZY	12
14	10180PC	COVER WEAR PAD 23000	2
15	C5902	WASHER 0.63 SAE FLAT YELLOW GR8	12
16	C1025	CAP SCR 0.63-11X2.00 HHGR8 ZY	12
17	25574	BUSHING 40DXR20 2.50X1.25	4
18	8819	BUSHING QSI-3235-16	2
19	13343	BUSHING 40DXR16 GARLOCK	4
20	17320	BUSHING 40DXR40 GARLOCK	4
21	40455	WEAR PAD 2.00X8.00X1.50	2
22	16266ZP	PIN 2.00X8.19 D&T	2
23	9996ZP	PIN 2.50X9.38 D&T	2
24	58052	SET SCREW 0.50-13X0.50	4

BASE WELDMENT SHOWN AS REFERENCE



# Outrigger Cylinder Assembly - PN 48383

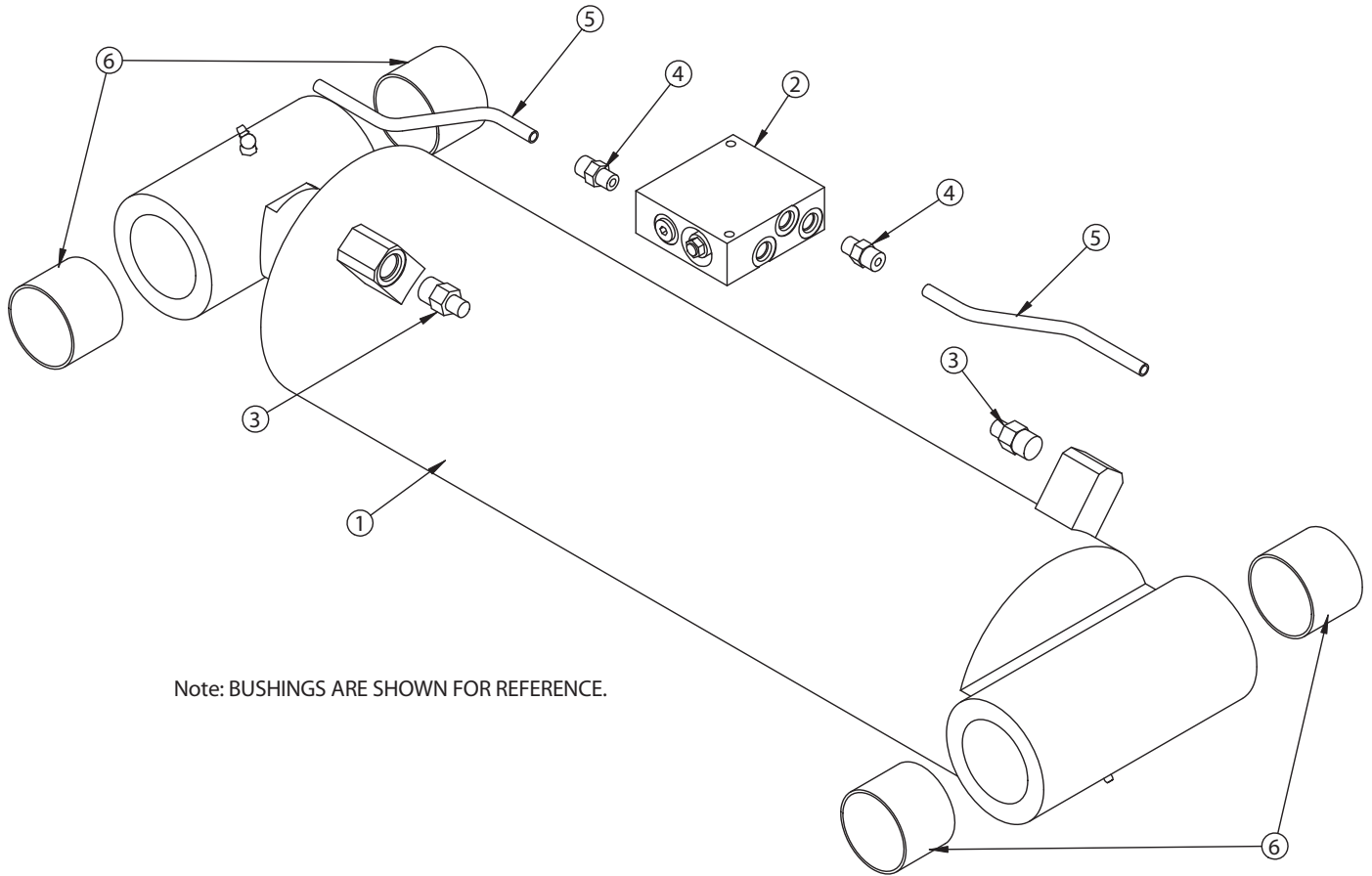

## PN 48383

ITEM	PART	DESCRIPTION	QTY.
1	48384	CYLINDER 7.00X19.25	1
2	15822	MANIFOLD DOUBLE T11A 5000 PSI	1
3	D1290	FTG ADAPT 8-6 F5OLO-S	2
4	0279	FTG ADAPT 6-F5OLO-S	2
5	19032	TUBE ASM 0.38 X 6.91	2
6	0635	BUSHING 40DXR32 GARLOCK	4

# Reservoir Assembly - PN 41332

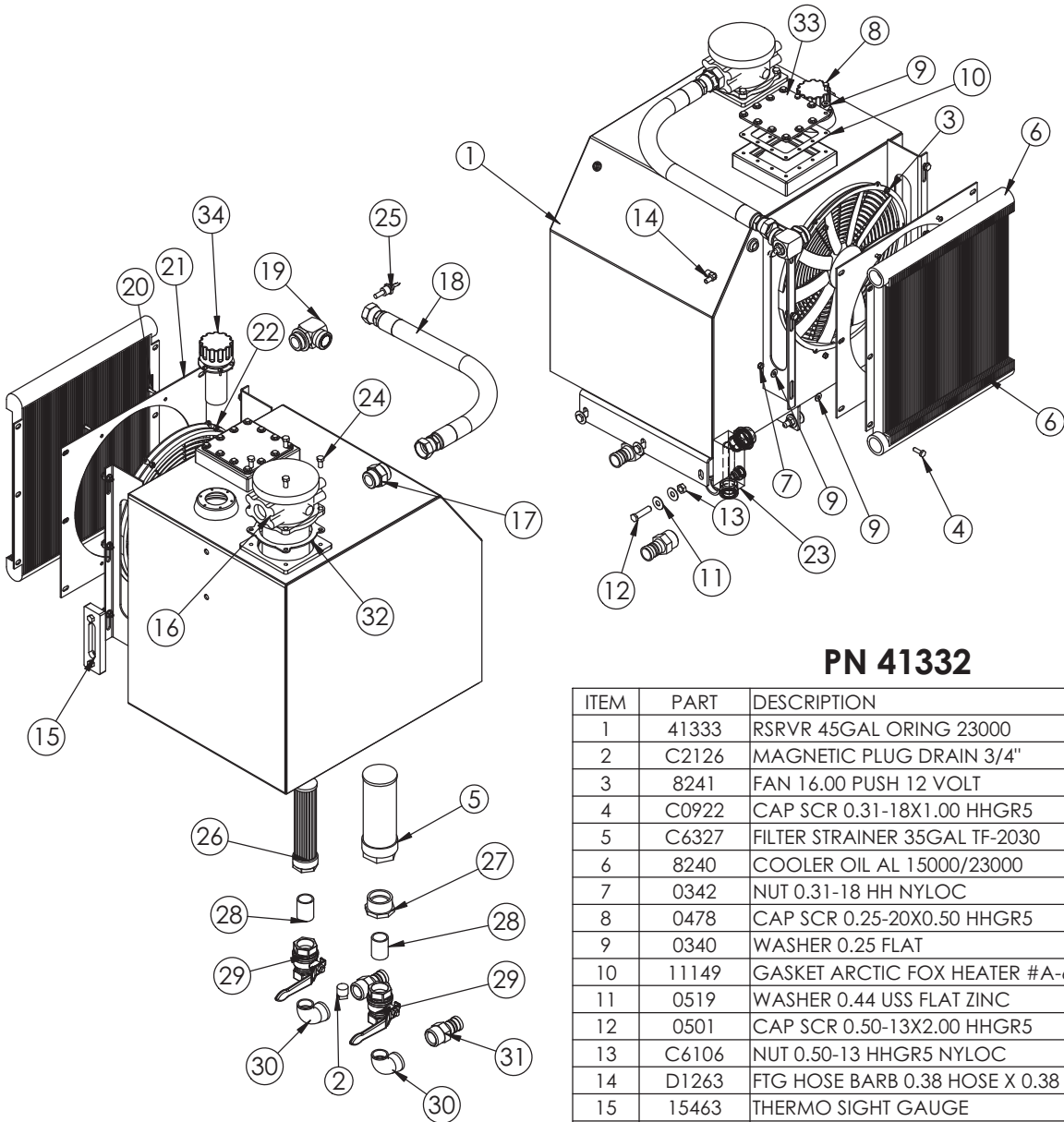

## PN 41332

ITEM	PART	DESCRIPTION	QTY.
1	41333	RSRVR 45GAL ORING 23000	1
2	C2126	MAGNETIC PLUG DRAIN 3/4"	1
3	8241	FAN 16.00 PUSH 12 VOLT	1
4	C0922	CAP SCR 0.31-18X1.00 HHGR5	6
5	C6327	FILTER STRAINER 35GAL TF-2030	1
6	8240	COOLER OIL AL 15000/23000	1
7	0342	NUT 0.31-18 HH NYLOC	6
8	0478	CAP SCR 0.25-20X0.50 HHGR5	12
9	0340	WASHER 0.25 FLAT	24
10	11149	GASKET ARCTIC FOX HEATER #A-611	1
11	0519	WASHER 0.44 USS FLAT ZINC	12
12	0501	CAP SCR 0.50-13X2.00 HHGR5	6
13	C6106	NUT 0.50-13 HHGR5 NYLOC	6
14	D1263	FTG HOSE BARB 0.38 HOSE X 0.38 90DG	1
15	15463	THERMO SIGHT GAUGE	1
16	42184	FILTER TANK TOP MPF1841AG7A10HBVR	1
17	19242	FTG 20-20 MFS-MORB STRAIGHT	1
18	47858	HOSE 1.25(881-JC-JC-20-20-20-26)	1
19	47857	FTG 23000 RSRVR TEMP	1
20	C6021	CAP SCR 0.25-20X0.75 BTNHD SS	4
21	30012	SHROUD RSRVER ASM 9000	1
22	0333	NUT 0.25-20 HHGR5 NYLOC	4
23	47859	FTG 23000 RSRVR RETURN	1
24	0492	CAP SCR 0.38-16X0.75 HHGR5	4
25	54393	SWITCH TEMP NC TT-F5B-100R-MP	1
26	C5552	FILTER STRAINER TFS-1220-0	1
27	C4907	BUSHING 2.00X1.25 BLK	1
28	C1057	FTG 20-20XCLOSE MP-MP NIPPLE STRAIGHT BLK	2
29	C5511	VALVE BALL 1.25	2
30	C4694	ST EL 1.25 90 DEG BLK	2
31	C2282	FTG 1.25 NPT TO 1.25 BARB	2
32	58284	GASKET TANK TOP FILTER	1
33	11442PC	PLATE COVER TANK HEATER FLANGE	1
34	63029	CAP FILL ASM W/NECK	1

# Optional 15 Ton Hook Kit - PN 55138

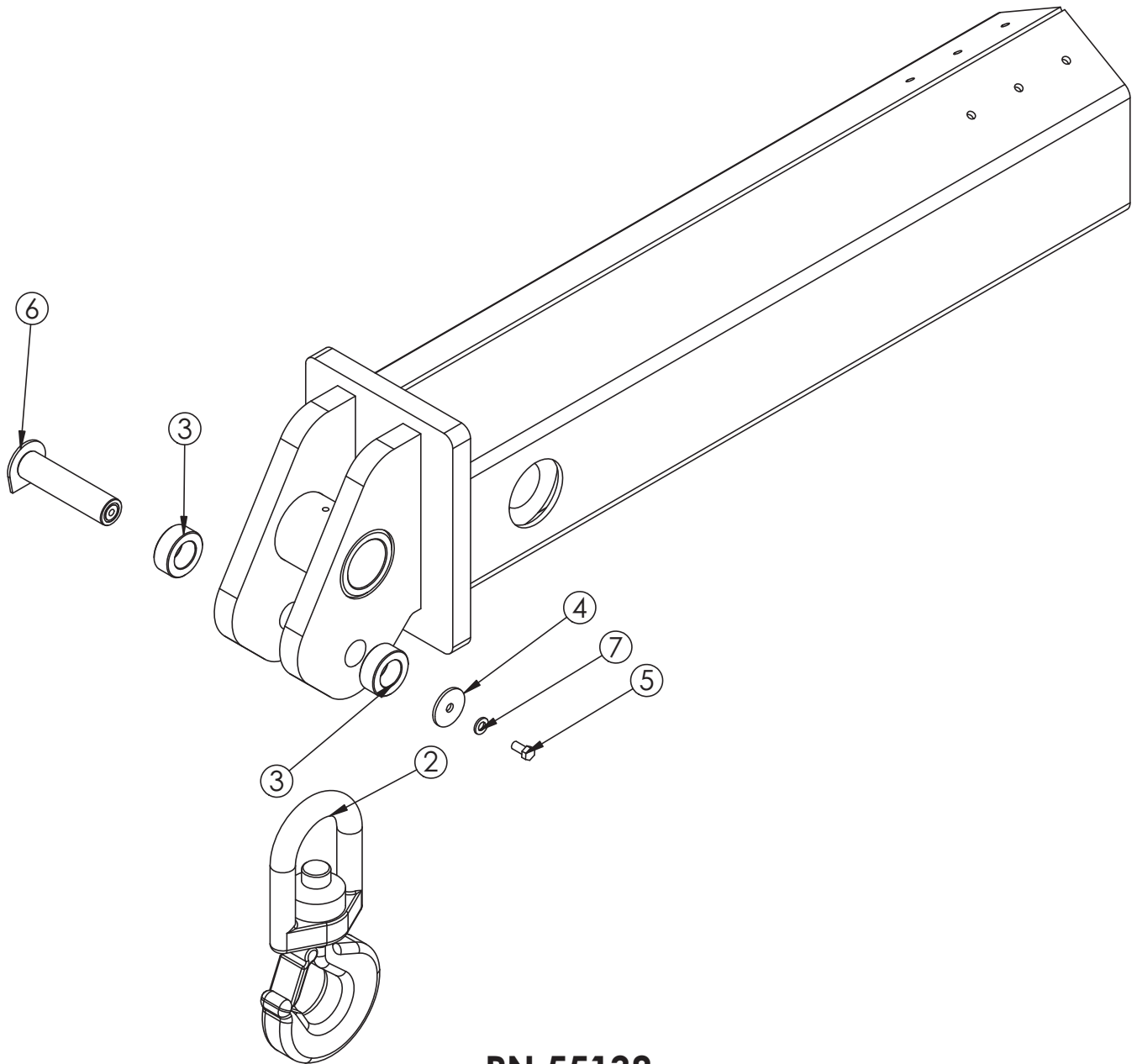

## PN 55138

ITEM	PART	DESCRIPTION	QTY.
1	15388	EXT BOOM 28000	1
2	41499	HOOK 15 TON SWIVEL CROSBY 1028654	1
3	44069PC	COLLAR 1.78X3.00X1.19	2
4	9142	PIN CAP 0.56X2.50X0.19	1
5	10172	CAP SCR 0.50-13X1.00 HHGR8 ZY	1
6	16028ZP	PIN TEAR DROP 1.75X7.06	1
7	D0790	WASHER 0.50 FLAT GR8	1

# Chapter 8 - Hydraulics - Electrical

## WARNING!

**Please read the following section before performing any work on the hydraulic/electrical system of your crane. This section contains vital safety information and maintenance guidelines for your crane. If questions should arise, please contact Stellar Customer Service at 800-321-3741**

Never modify or alter any of the equipment, whether mechanical, electrical, or hydraulic, without Stellar Industries' approval.

Release system pressure before attempting to make adjustments or repairs.

Do not attempt service or repair when PTO is engaged.

Disassemble and assemble hydraulic components on a clean surface.

Clean all metal parts in a nonflammable cleaning fluid. Then lubricate all components to aid in assembly.

Hydraulic fluid expands when heated. This raises the pressure in an unventilated tank. Release the tank pressure before removing the cap completely. Failure to do so may cause the oil to shoot out of the tank very rapidly and cause severe burns.

Warning! If hydraulic fluid escapes, the boom or crane can fall immediately. Make sure the ground or blocking is supporting the boom before performing any maintenance or repair. Do not rely on the hydraulic fluid to support the boom or crane.

Contaminants in a hydraulic system affect operation and will result in serious damage to the system components. Dirty hydraulic systems are a major cause of component failures.

If evidence of foreign particles is found in the hydraulic system, flush the system.

When installing metal hydraulic tubes, tighten all bolts finger tight. Then, in order, tighten the bolts at the rigid end, the adjustable end, and the mounting brackets. After tubes are mounted, install the hoses. Connect both ends of the hose with all bolts finger tight. Position the hose so it does not rub the machine or another hose and has a minimum of bending and twisting. Tighten bolts in both couplings.

Due to manufacturing methods, there is a natural curvature to a hydraulic hose. The hose should be installed so any bend is with this curvature.

# Control Kit - PN 41919

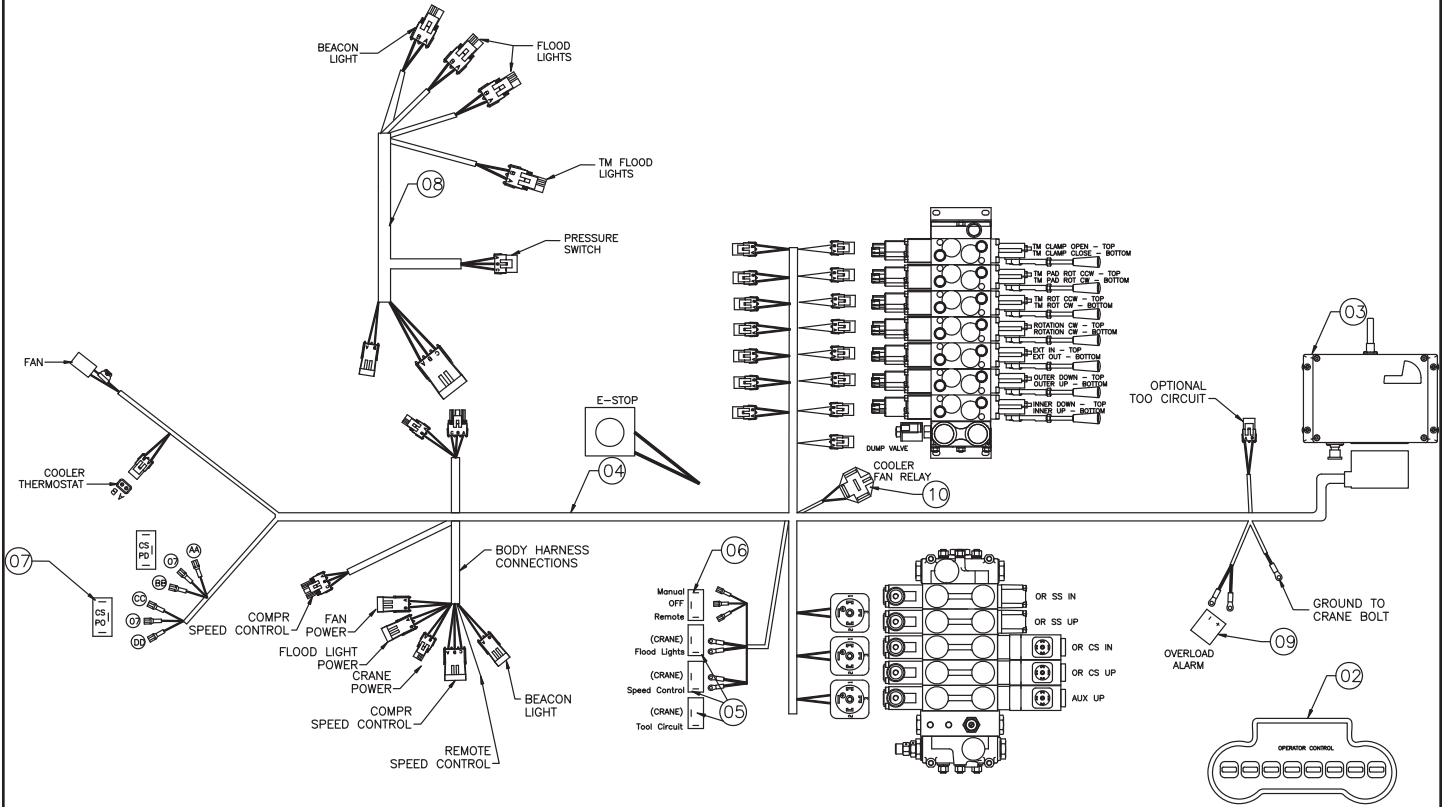

## PN 41919

ITEM	PART No.	DESCRIPTION	QTY
01	41922	CONTROLLER ASSEMBLY (incl:2-3)	1
02	.	HANDLE ASSEMBLY	1ref
03	.	CONTROL BOX	1ref
04	41920	WIRE HARNESS 28000 CRANE	1
05	C4815	SWITCH, TOGGLE ON/OFF	3
06	8623	SWITCH TOGGLE ON-OFF-ON SGL P DBL T	1
07	6394	SWITCH TOGGLE MOM/ON/OFF/ON	2
08	41921	WIRE HARNESS 28000 LMI&LIGHTS	1
09	D0045	BACKUP ALARM .97 DECIBAL	1
10	C6072	RELAY BOSCH 20-30 AMP	1
11			

# Control Kit (434 Mhz Option) - PN 51838

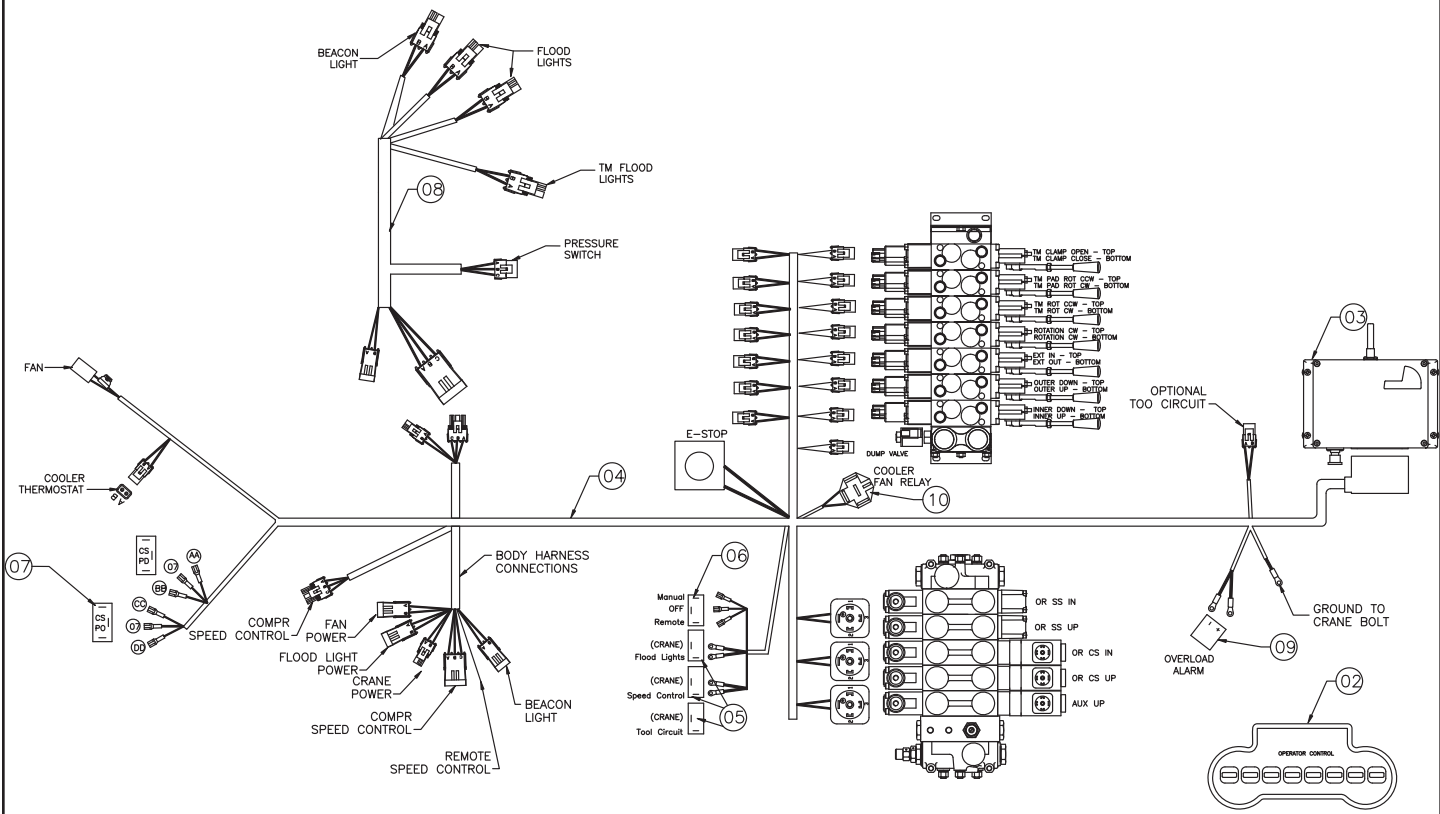

## PN 51838

ITEM	PART No.	DESCRIPTION	QTY
01	50220	CONTROLLER ASSEMBLY (incl:2-3)	1
02	.	HANDLE ASSEMBLY	1ref
03	.	CONTROL BOX	1ref
04	41920	WIRE HARNESS 28000 CRANE	1
05	C4815	SWITCH, TOGGLE ON/OFF	3
06	8623	SWITCH TOGGLE ON-OFF-ON SGL P DBL T	1
07	6394	SWITCH TOGGLE MOM/ON/OFF/ON	2
08	41921	WIRE HARNESS 28000 LMI&LIGHTS	1
09	D0045	BACKUP ALARM .97 DECIBAL	1
10	C6072	RELAY BOSCH 20-30 AMP	1
11			

# Control Kit (419 Mhz Option) - PN 55395

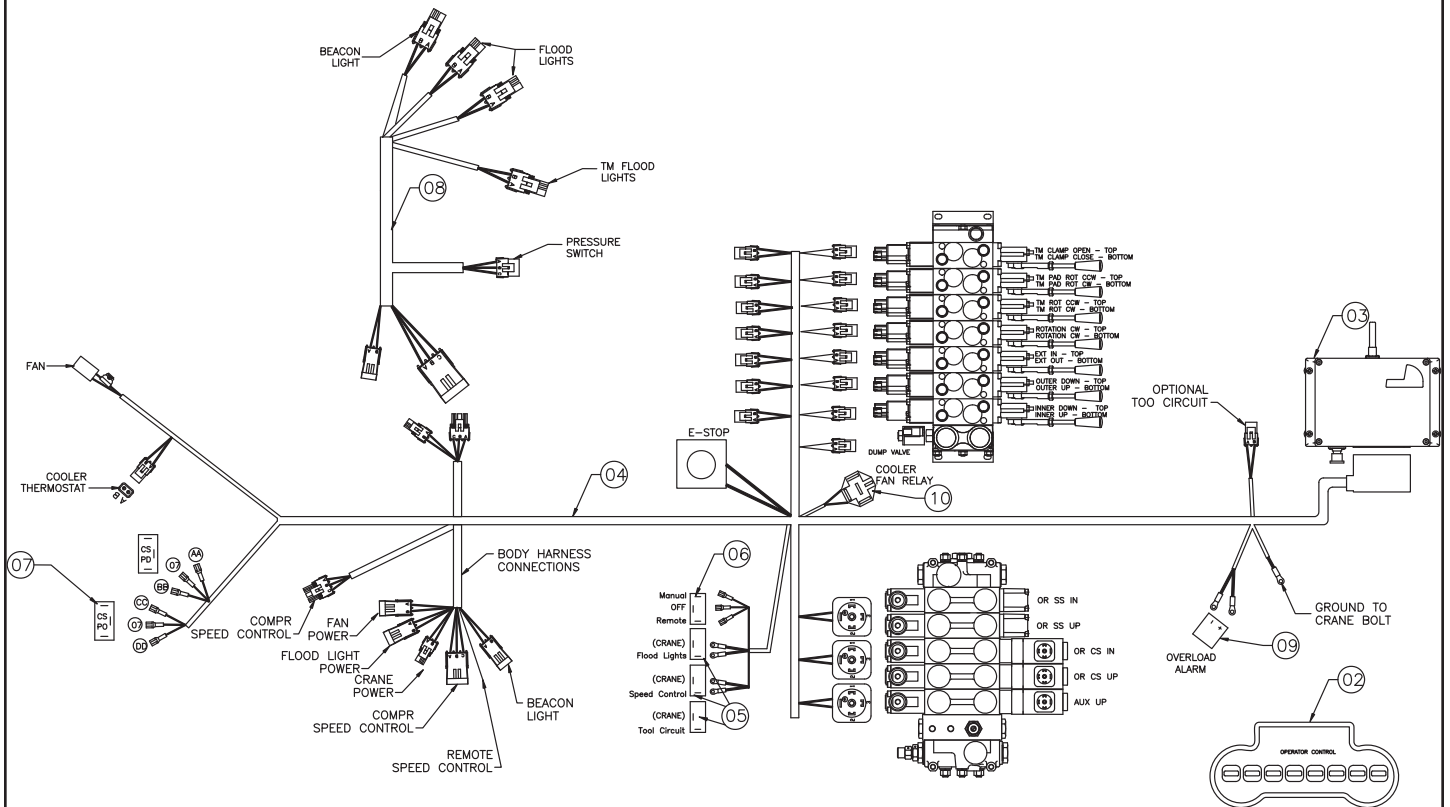

## PN 55395

ITEM	PART No.	DESCRIPTION	QTY
01	50219	CONTROLLER ASSEMBLY (incl:2-3)	1
02	.	HANDLE ASSEMBLY	1ref
03	.	CONTROL BOX	1ref
04	41920	WIRE HARNESS 28000 CRANE	1
05	C4815	SWITCH, TOGGLE ON/OFF	3
06	8623	SWITCH TOGGLE ON-OFF-ON SGL P DBL T	1
07	6394	SWITCH TOGGLE MOM/ON/OFF/ON	2
08	41921	WIRE HARNESS 28000 LMI&LIGHTS	1
09	D0045	BACKUP ALARM .97 DECIBAL	1
10	C6072	RELAY BOSCH 20-30 AMP	1
11			



# Hydraulic Kit - PN 48690

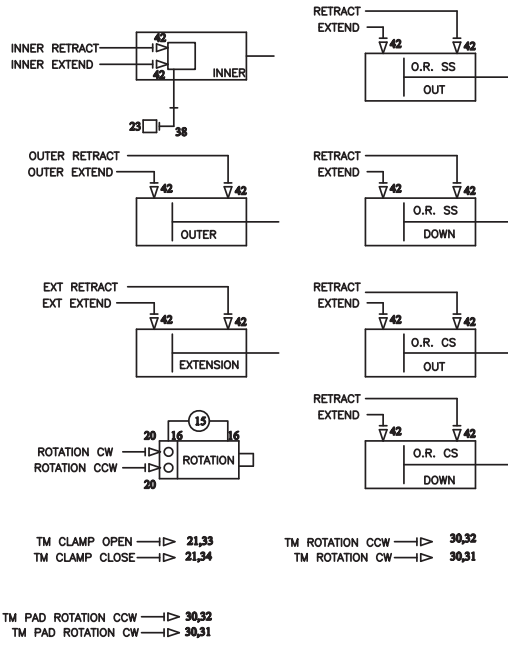
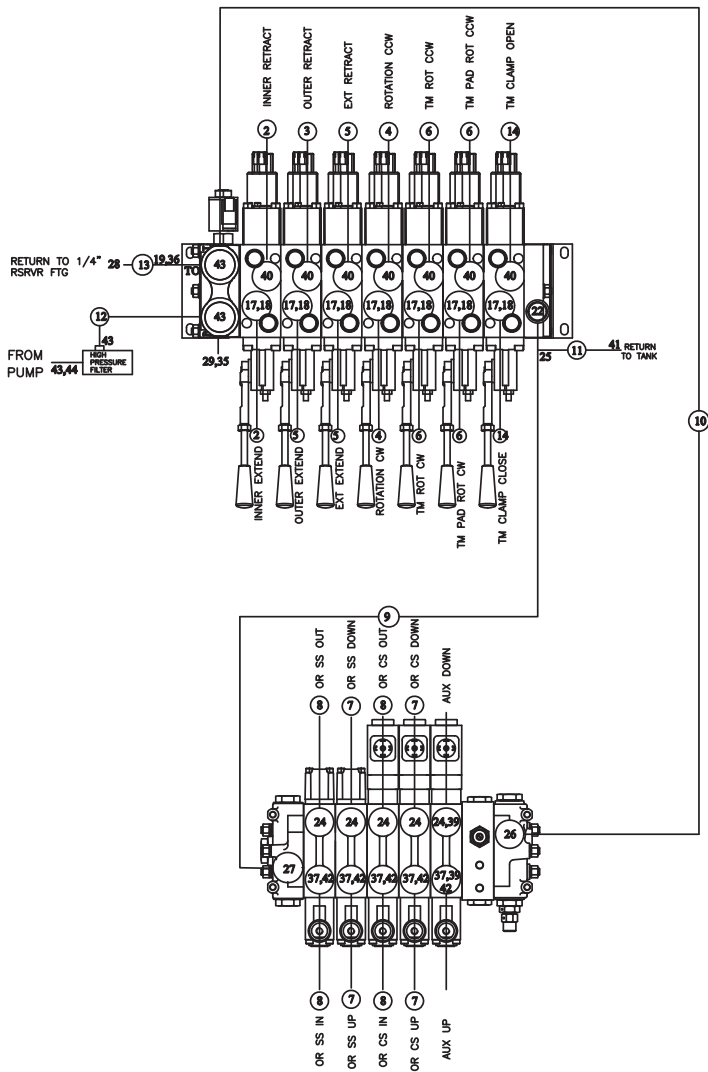

## PN 48690

22	14354	FTG ADAPT 90 12-10-C50LO-S	1	44	C2376	FTG ADAPT 8-C6LO-S	1
21	47406	FTG BULK MSTR/ORFS 8 WF50LO-WLNL-S	2	43	C1180	FTG ADAPT 8-12 F50LO-S	4
20	C1855	FTG ADAPT 6-10 F50LO-S	2	42	C1854	FTG ADAPT 6-8 F50LO-S	19
19	D1314	FTG ADAPT 4-C6LO-S	1	41	C4903	FTG ADAPT 6-8 F50LO-S	1
18	25361	FTG ADAPT 6-10 F50LO-S	7	40	D1302	FTG ADAPT 90 6-10-C50LO-S	7
17	C1111	FTG ADAPT MSTR/FSTR 10-6 F50G5	7	39	0882	CAP 6 FNL-S	2
16	C1198	FTG ADAPT 4-C50LO-S	7	38	3861	FTG 90 MSTR/FSTR 6	2
15	55677	HOSE-HYD 0.25 X 12	1ref	37	C2248	FTG ADAPT 6 C6LO-S	5
14	47423	HOSE-HYD 0.38 X 288	2ref	36	52820	FTG 90 MFS/MAORB 4-5-NWO-FG	1
13	39895	HOSE-HYD 0.25 X 108	1ref	35	44521	FTG ADAPT MSTR/FSTR 5-4 F50G5	1
12	16627	HOSE-HYD 0.50 X 24	1ref	34	13556	QUICK COUPLER 2FFN38-12SAE-F	1
11	9104	HOSE-HYD 0.75 X 72	1ref	33	13557	QUICK COUPLER 2FFN38-12SAE-M	1
10	18700	HOSE-HYD 0.50 X 30	1ref	32	13555	QUICK COUPLER 2FFI14-38SAE-M	2
09	31665	HOSE-HYD 0.75 X 30	1ref	31	13554	QUICK COUPLER 2FFI14-38SAE-F	2
08	16493	HOSE-HYD 0.38X 84	4ref	30	47405	FTG BULK MSTR/ORFS 6 WF50LO-WLNL-S	4
07	11874	HOSE-HYD 0.38 X 102	4ref	29	39780	GAUGE OIL LF 2.5 0-5000 CBM SAE	1
06	16663	HOSE-HYD 0.38 X 288	4ref	28	D1942	FTG ADAPT 4-4 FLO	1
05	15815	HOSE-HYD 0.38 X 240	2ref	27	7344	FTG ADAPT 12-8 F50LO-S	1
04	16662	HOSE-HYD 0.38 X 42	2ref	26	1556	FTG ADAPT 90 8-C50LO-S	1
03	16661	HOSE-HYD 0.38 X 180	2ref	25	D0525	FTG TEE O-RING F SL 12 R6LO-S	1
02	14872	HOSE-HYD 0.38 X 72	2ref	24	C5547	FTG ADAPT 6-8 C50LO-S	5
01	48692	HOSE KIT,28000 CRANE (incl:2-14)	1	23	55394	SWITCH PRES OVERLD CD-11C-5500R/WD	1
ITEM	PART No.	DESCRIPTION	QTY	ITEM	PART No.	DESCRIPTION	QTY



# Chapter 9 - Replacement Parts

## HYDRAULIC SYSTEM COMPONENTS

PART#	DESCRIPTION
39780	Oil pressure gauge
8240	Oil cooler
22934	Hydraulic rotation motor ( Crane rotation )
22935	Valve block hydraulic motor (Crane rotation)
28485	Pressure transducer (overload)
41338	High pressure filter asm
47860	High pressure filter element (Used in p/n 41338)
18552	Fill cap assy with neck (Hydraulic reservoir)
15463	Thermo sight gauge (Hydraulic reservoir)
11149	Gasket - (Optional Artic heater cover)
C6327	Filter Strainer ( Hydraulic reservoir )
42184	Hydraulic return filter asm (Hydraulic reservoir)
47820	Hydraulic filter element (Used in p/n 42184)
47866	Control Handle - Valve bank (PVG32)
C1090	Counter balance valve ( Cylinders )
C6184	Counter balance valve (Extension & Outrigger cylinders)
15995	Manifold asm dual T2 - 5000 psi (Cylinder)
42802	Valve bank - 7 section
40827	Valve bank - 5 section
55401	Relief valve - (5 section valve bank)
50234	Dump valve - (7 section valve bank)
50235	Dump valve coil - (7 section valve bank)
47871	Valve - LMI system
13555	Hydraulic quick coupler
13554	Hydraulic quick coupler
13557	Hydraulic quick coupler
13556	Hydraulic quick coupler
C2028	O ring ( # 6 face seal ) ( hydraulic fittings )
C2029	O ring ( # 8 face seal ) ( hydraulic fittings )
32223	O ring ( #10 face seal ) ( hydraulic fittings )
D1244	O ring ( #12 face seal ) ( hydraulic fittings )
D1245	O ring ( # 4 SAE port side ) ( hydraulic fittings )
D1246	O ring ( # 6 SAE port side ) ( hydraulic fittings )
D1247	O ring ( # 8 SAE port side ) ( hydraulic fittings )
D1248	O ring ( #10 SAE port side ) ( hydraulic fittings )
D1249	O ring ( #12 SAE port side ) ( hydraulic fittings )
D1250	O ring ( #16 SAE port side ) ( hydraulic fittings )
16158	Port tube asm - ( 15604 secondary cylinder )
35647	Seal kit - Outrigger cylinder ( 9994 )
C6310	Seal kit - Outrigger cylinder ( 9993 )
35651	Seal kit - Main lift cylinder ( 15598 )
35650	Seal kit - Secondary cylinder ( 15604 )
35649	Seal kit - Extension cylinder ( 15608 )

## ASSEMBLY COMPONENTS

PART#	DESCRIPTION
0635	Bushing 2.50" x 2.00"
0865	Bushing 3.00" x 2.00"
2227	Bushing 3.00" x 3.00"
4381	Bushing 2.00" x 2.00"
5739	Bushing 2.50" x 3.00"
8819	Bushing 2.00" x 1.00"
13343	Bushing 2.50" x 1.00"
13817	Bushing 2.50" x 1.50"
17320	Bushing 2.50" x 2.50"
25574	Bushing 2.50" x 1.75"
8377	Pin Cap 0.56 x 3.50" x .25 SS
8597	Pin Cap 0.69 x 4.00" x .25 SS
9142	Pin Cap 0.56 x 2.50" x .25 SS
10172	Cap Screw 0.50-13 x 1.00 Gr 8
D0790	Washer 0.50 Flat Gr 8
2257	Snap ring 2.00" Internal
C5644	Grease Zerk 1/8 NPT 45 degree (Grease line kit option)
C1592	Grease Zerk 1/8 NPT (Cylinders / pivot points)
40455	Wear Pad 2.00" x 8.00" x 1.50"
15779	Wear Pad 3.00" x 5.00" x 1.75"
15778	Wear Pad 3.00" x 5.00" x 2.44"
15601	Wear Pad 1.00" x 4.00" x 12.00"
17133	Hose clamp
39959	Gear bearing rotation kit
16054	Swivel link ( 15-ton hook )
16052	Hook 15-ton Swivel

## ELECTRICAL COMPONENTS

PART#	DESCRIPTION
41922	Hetronic Nova radio system
47862	12v charger for Hetronic Nova radio system
47863	Battery for Hetronic Nova radio system
47867	Belt - Transmitter harness (waist)
8241	Fan 16.00 push 12 V ( Hydraulic reservoir )
6394	Toggle switch ( Outrigger operation )
8623	Toggle switch ( Outrigger operation )
C4815	Toggle switch ( Outrigger operation )
54393	Temperature switch ( Hydraulic reservoir )
22921	E-stop switch ( Crane panic bar )
61562	CONTACT SWITCH (PANIC BAR) Switch inside E-stop housing (22921)
41367	LMI system (Load Moment Indicator)
31782	Wire harness - LMI & Lights
41368	Wire harness - LMI Cinch Retro
D0045	Overload alarm

## COMPRESSOR COMPONENTS (SHD245 OPTIONAL)

PART#	DESCRIPTION
3853	Pilot valve 145/175 psi (SHD245 cprsr)
C4913	Solenoid valve (SHD245 cprsr)
C4914	Pressure Relief valve (SHD245 cprsr)
C0864	Hobbs air pressure switch (SHD245 cprsr)
13731	Low pressure intake valve asm (SHD245 cprsr)
13733	High pressure intake valve asm (SHD245 cprsr)

## SERVICE KITS / FILTERS / LUBRICATION

PART#	DESCRIPTION
4562	Air filter (SHD245 cprsr)
32893	Service Kit - 200 hour (SHD245 cprsr)
4460	Molube grease-external gear teeth for swing gears

## MISCELLANEOUS COMPONENTS

PART#	DESCRIPTION
51263	Flood lights ( Crane & Body )
5033	Strobe light ( Crane & Body )
14022	Compartment light

**Call 800-321-3741 to Order**



# Chapter 10 - Troubleshooting

**This chapter will list a number of potential problems that may occur while operating the crane. Most problems are easily solved using the solutions portion of this chapter. If problems persist, please contact Customer Service at Stellar Industries 1-800-321-3741.**

**Problem: Crane will not operate.**

**Solutions:**

- Make sure that the parking brake is engaged.
- Make sure that the PTO is engaged.
- Make sure that there is 12V power going to the radio receiver. If there is no power going to the receiver, trace back to the power source and check for a blown fuse or loose ground connection.
- Make sure that the transmitter batteries are fully charged. (Rechargeable batteries are good for 11 months or 200 charges)
- Make sure that the hydraulic pump is operating at its rated flow or GPMs. Check the flow by using the flow meter to determine the GPMs. It is possible that the hydraulic pump is getting weak. If this is suspected, contact Stellar Customer Service.

**Problem: Crane operates slowly.**

**Solutions:**

- Make sure that the crane is receiving the recommended GPMs to operate.
- Check the level of hydraulic fluid in the reservoir. Add fluid as needed.
- Check to see if the valve bank proportional valve is operating.
- Make sure the proportional valve is receiving 12V power when operating a function.

**Problem: Crane will operate manually but will not operate electrically.**

**Solutions:**

- Make sure that there is 12V power going to the radio receiver. If there is no power going to the receiver, trace back to the power source and check for a blown fuse or loose ground connection.
- Make sure that the parking brake is engaged.
- Make sure that the parking brake switch is working properly. Check the parking brake switch by performing a continuity test. If the switch is defective, simply replace it.
- Make sure the "Power" LED is on outside the receiver door cover. This light is the upper light on the receiver door. If the light does not come on, check wiring back to the fuse. If the fuse is OK, check system ground wires and connections.
- Make sure the green LED on the receiver door is lit green. This light will come on when the red e-stop is pulled upward and the toggle switch is activated on the transmitter. If the radio system does not link up and no green light is lit on the receiver - make sure that the battery is fully charged, check the battery contact points to make sure they are not tarnished or corroded. Clean contact points and recharge or replace the battery.
- When battery voltage is acceptable, the power LED light on the transmitter will be solid. If the voltage becomes low, the LED light will begin to blink and the battery will need to be charged or replaced.

**If problems persist, please contact Stellar Customer Service at:  
1-800-321-3741**

**Problem: Not all crane functions operate using the radio remote transmitter or crane operates intermittently.**

**Solutions:**

- Make sure that the function switch is working properly. If the switch is defective, simply replace it.
- Make sure that there is power going from the valve bank twin solenoid or to the function that will not operate. If no power is going to the twin solenoid, check wiring connections on wire harness plug connector for broken wires, loose connection or poor crimp. If power is going to the solenoid valve, it may not be opening to allow hydraulic oil to the function that is not operating. Check the twin solenoid for polarity, if solenoid does not magnetize, replace the twin solenoid.

**Problem: Cylinder drifts outward or downward.**

**Solutions:**

- Check to see if there is air in the hydraulic system. Operate all cylinders connected to the hydraulic system. Start with the extension cylinder, then operate the main boom, winch, rotation, and ending with the hydraulic outriggers, if installed. When operating, extend each cylinder halfway out, retract all the way in, and then extend until the cylinder rod is at the end of its stroke. Operate cylinders slowly so air is pushed thru the system to the reservoir. Repeat this cycle 2-3 times.
- Make sure the holding valves are operating properly. Remove, clean, and then inspect each holding valve. When removing a holding valve, always relieve the pressure inside the cylinder by loosening jam nut of the holding valve and turning set screw inward/clockwise. Count the number of turns until the set screw is seated. When reinstalling the holding valve, make sure the valve is reset by turning the set screw the number of turns it took to relieve the pressure. Finish by tightening the jam nut.
- Check the cylinder rod for scratches. If a scratch is located on the cylinder rod, hydraulic fluid can pass thru and cause a loss of pressure. Replace cylinder rod or cylinder.
- Check to see if the piston seals are damaged. If they show signs of damage, install a new cylinder seal kit.

**Problem: Outer "Extend" and Extension In and Out will not operate Manually or Remotely.**

**Solutions:**

- Check to see if the functional cut out connector, located on the valve section is lit. Note: Functional cut out connectors will have an LED light on when electrical power is present
- Check to see if there is 12 volt power going to functional cut out connector.
- Check to make sure the Bosch relay is functioning properly. It is located just behind the panic bar E-stop switch. If functional cut out connector is lighting properly, check to make sure the connector is tight.

## Troubleshooting continued...

Problem	Possible Cause	Possible Solution
Vibrations and jerking in hydraulic cylinder during the first maneuvers.	The temperature of the hydraulic oil is too low.  lack of oil in reservoir.	Perform maneuvers without loads for several minutes to warm up the oil.  Add hydraulic oil.
Vibrations with every function when oil is hot.	Lack of oil in reservoir.  air in hydraulic system.	Add hydraulic oil to the tank.  Operate the control carrying the cylinders to stroke end several times in both directions.
All crane movements are slow, loaded and unloaded.	Suction hose from oil tank crushed or obstructed.  Dump valve malfunctioning.  The pump is drawing in air.	Replace or clean the suction hose.  Manually override system to detect  Tighten suction hose connections.
The hydraulic extension is not extending.	Bad lubrication.  Wear pads are worn.  Sequence valve on extension cylinder has to be adjusted.	Lubricate the wear pads  Replace wear pads.  Check to see if there is 12V power going to the extension function.
Crane rotation not regular	Inadequate grease.  The truck is not level.  Worn rotation motor.  Gear bearings worn.	Grease gear bearing.  Level the truck.  Replace rotation motor.  Replace gear.
The crane does not lift the loads on the load chart.	Defective hydraulic pump.  Incorrect settings of the valves.  Hydraulic cylinder seals are worn.	Replace the pump.  Adjust valve settings.  Replace worn seals.
The crane lifts the load, but cannot hold it.	Incorrect relief setting.  Faulty holding valve.  Incorrect settings of the valves.  Hydraulic cylinder seals are worn.	Contact Stellar customer service for proper setting. Replace holding valve.  Adjust valve settings.  Replace worn seals.
Noise coming from Articulation points.	Lack of lubrication.  Worn pin.  Worn bushing.	Grease articulation points.  Replace pin.  Replace bushing.



Problem	Possible Cause	Possible Solution
Hydraulic legs do not hold under load.	Defective holding valves Worn seals in the stabilizer cylinder.	Clean or replace holding valves. Replace worn seals.
Crane does not function.	Truck battery discharged Electric connections are damaged or corroded. Control handle turned off.	Charge battery. Check electrical wiring, terminals, connections and their integrity. Turn on control handle
Crane does not function - Continued	Battery charge low. Burned fuses Dump valve not operating properly. PTO not fully engaged.	Charge transmitter battery. Replace the fuses. Bypass electrical circuit Check for full engagement.
Control box lights do not operate (green LED out)	Discharged battery. Burned fuses. Disconnected electrical cord. Corroded or loose electrical connections. Faulty manual/remote switch.	Recharge battery. Replace fuses. Join correctly the connection, replace the electric coupling. Check electrical connections. Replace switch.
A crane function does not work.	Defective switch. Faulty solenoid. Locked valve cartridge. Damaged electric connection.	Replace the switch. Replace the solenoid. Disassemble and clean the valve cartridge. Check continuity of the circuit.
Operations at high or low speed do not work.	Parameters of control box (receiver) set incorrectly or have failed.	Contact Stellar customer service department.
Controls fail to respond with control box.	Batteries dead in wireless handle. Handle on/off button isn't turned on. Manual/remote switch is in manual position.	Recharge or replace batteries in remote handle. Turn on on/off button on remote handle. Position manual/remote switch in remote position.
Operation slow down.	Hydraulic oil supply is low. Hydraulic pump is operating at a reduced speed. Relief valve is set too low. Pump or cylinder is worn.	Add hydraulic oil. Engine idle speed may be too slow, increase speed. Check relief with gauge. Replace cylinder seals.

Problem	Possible Cause	Possible Solution
Operation slow down - con't	<p>Pump is slipping due to excessive oil temperature, this is a factor which will increase with worn components.</p> <p>Filters are dirty.</p> <p>Obstruction has occurred in boom holding valve.</p>	<p>Check pump GPM with flow meter if it is suspected to be faulty.</p> <p>Replace filters.</p> <p>Replace or clean holding valve.</p>
Operation slow down - con't	Defective flow valve.	Replace valve.
Boom drifts when loaded and controls neutralized.	<p>Hydraulic oil is bypassing at piston seal.</p> <p>Main or secondary cylinder holding valves are defective or contaminated.</p>	<p>Replace cylinder.</p> <p>Clean or replace holding valves.</p>
Unusual noise in operation.	<p>Cavitation is occurring due to low hydraulic oil supply.</p> <p>Restriction or collapse of suction line has occurred.</p> <p>Suction line screen is clogged and requires replacement.</p>	<p>Add oil and cycle cylinders to get air out of system.</p> <p>Inspect suction line for damage.</p> <p>Replace or clean screen.</p>
Unusual noise in operation - con't	<p>Bypass settings on relief valve are too low.</p> <p>Relief valve is damaged.</p>	<p>Contact customer service for correct relief setting.</p> <p>Replace relief valve.</p>
Outriggers fail to retract	<p>Control valve is inoperative.</p> <p>Cylinder seals or holding valve are defective</p> <p>Hydraulic lines are restricted or ruptured.</p>	<p>If outriggers retract using manual function, it is a probable electrical problem - check continuity.</p> <p>Replace seals or holding valve.</p> <p>Inspect and replace hydraulic lines.</p>
Outriggers fail to retract-con't	Broken electrical wire going to outrigger switch to the valve bank.	Check continuity of circuit.
Outriggers yield or drift.	<p>Control valve is inoperative.</p> <p>Cylinder or check valve is defective. Hydraulic lines are restricted or ruptured.</p>	<p>Clean or replace pulsar solenoid valve. Replace holding valve.</p> <p>Check hoses for damage and replace.</p>

# BMS-2 Receiver Troubleshooting

*Available on some systems. Consult BMS-2 Operator Manual for details.*

Problem	Probable Cause	Correction
System will not initialize after normal start-up procedure.	E-Stop reset	Push the Start button again. If the system is being initialized from an E-Stop condition, the Start button must be pressed twice - first to clear the E-Stop, then again, to start the system.
	Joystick or paddle lever not in center position.	Be sure that all joysticks and paddle levers are in center position when the Start button is activated.
	E-Stop switch engaged.	Pull out E-Stop switch. Restart system by pressing Start twice.
	Battery fully discharged.	Check battery to ensure a full charge. Replace with fully charged battery if necessary.
	No power to the receiver.	Check the diagnostic Display on the side of the receiver to be sure power is applied. Ensure that the system is securely grounded to the negative battery terminal. The Display also indicates normal transmitter communication, interference, and E-Stop conditions.
The transmitter is turned on, but does not transmit (Power LED not flashing)	Battery is discharged.	Replace battery with a fully charged battery.
	Coder board fuse.	Check fuse and replace if necessary.
	Broken key switch.	Check wiring on key switch. Replace key switch, wiring or contact element.
	Coder board failure.	Contact Hetronic or your Dealer.
Transmitter is transmitting (Power LED flashing), but crane will not respond.	E-Stop switch engaged.	Pull out the E-Stop pushbutton and press the Start/Horn pushbutton.
	Transmitter out of range.	Take the transmitter back into the range of the receiver. Press the Start/Horn pushbutton.
	Joystick, paddle lever or switch not in center position when transmitter turned on.	Ensure that all control devices are in center (neutral) position when the Start button is activated.
	Receiver power off.	Turn on power to receiver.
	Blown fuse in receiver.	Check all fuses. Replace if necessary.
	E-Stop failure in transmitter.	Check E-Stop pushbutton for damage. Check wiring to contact element for broken or disconnected wires. Repair or replace E-stop pushbutton or wiring.
	E-Stop failure in receiver. Red E-Stop LED on decoder board is illuminated.	Check wiring on E-Stop module, decoder module, E-Stop decoder module. Secure any loose connections.
All crane/machine motions operate intermittently	Receiver antenna loose or missing.	Tighten or replace antenna.
	External antenna (if used) has loose connection, poor grounding or interference.	Tighten antenna and ground connection. See "Connecting an External Antenna" Section for operational precautions.
	Connector wiring too close to power wiring.	Control wiring must be run separately from power wiring.
	Connector inside receiver is loose.	Check all connectors, reseat if necessary.
Some crane/machine motions operate intermittently	Crane/machine motion wiring may be loose.	Check wiring from receiver to plug and from plug to crane/machine motion actuator.
	Connector inside receiver is loose.	Check all connectors, reseat if necessary.
	Connector wiring too close to power wiring.	Control wiring must be run separately from power wiring.





## Limited Warranty Statement

Stellar Industries, Inc. (Stellar) warrants products designed and manufactured by Stellar to be free from defects in material and workmanship under proper use and maintenance. Products must be installed and operated in accordance with Stellar's written instructions and capacities. This warranty shall cover the following:

**Stellar Cranes, Stellar Hooklift Hoists, Stellar Cable Hoists, Stellar Container Carriers, Stellar Service Trucks, and Stellar X-Tra-Lift Systems:**

*Twelve (12) month warranty on parts from the date recorded by Stellar as the in-service date, not to extend beyond twenty-four (24) months from date of manufacture,*

*Twelve (12) month repair labor from the date recorded by Stellar as the in-service date, not to extend beyond twenty-four (24) month from date of manufacture, and*

*Thirty-six (36) month warranty on all Stellar Manufactured structural parts from the date recorded by Stellar as the in-service date, not to extend beyond forty-eight (48) months from date of manufacture.*

**Stellar Tarper Systems:**

*Twelve (12) month warranty on parts from the date recorded by Stellar as the in-service date, not to extend beyond twenty-four (24) months from date of manufacture and*

*Three (3) month repair labor from the date recorded by Stellar as the in-service date, not to extend beyond fifteen (15) month from date of manufacture.*

The in-service date will be derived from the completed warranty registration card. In the event a warranty registration card is not received by Stellar, the factory ship date will be used.

Stellar's obligation under this warranty is limited to, and the sole remedy for any such defect shall be, the repair and/or replacement (at Stellar's option) of the unaltered part and/or component in question. Stellar after-sales service personnel must be notified by telephone, fax, or letter of any warranty-applicable damage within fourteen (14) days of its occurrence. If at all possible, Stellar will ship the replacement part within 24-hours of notification by the most economical, yet expedient, means possible. Expedited freight delivery will be at the expense of the owner.

Warranty claims must be submitted and shall be processed in accordance with Stellar's established warranty claim procedure. Stellar after-sales service personnel must be contacted prior to any warranty claim. A return materials authorization (RMA) account number must be issued to the claiming party prior to the return of any warranty parts. Parts returned without prior authorization will not be recognized for warranty consideration. All damaged parts must be returned to Stellar freight prepaid; freight collect returns will be refused. Freight reimbursement of returned parts will be considered as part of the warranty claim.

Warranty service will be performed by any Stellar new equipment distributor, or by any Stellar-recognized service center authorized to service the type of product involved, or by the Stellar factory in the event of a direct sale. At the time of requesting warranty service, the owner must present evidence of date of delivery of the product. The owner shall be obligated to pay for any overtime labor requested of the servicing company by the owner, any field service call charges, and any towing and/or transportation charges associated with moving the equipment to the designated repair/service provider.

All obligations of Stellar and its authorized dealers and service providers shall be voided if someone other than an authorized Stellar dealer provides other than routine maintenance service without prior written approval from Stellar. In the case repair work is performed on a Stellar-manufactured product, original Stellar parts must be used to keep the warranty in force. The warranty may also be voided if the product is modified or altered in any way not approved, in writing, by Stellar.

The owner/operator is responsible for furnishing proof of the date of original purchase of the Stellar product in question. Warranty registration is the ultimate responsibility of the owner and may be accomplished by the completion and return of the Stellar product registration card provided with the product. If the owner is not sure of registration, he is encouraged to contact Stellar at the address below to confirm registration of the product in question. This warranty covers only defective material and workmanship. It does not cover depreciation or damage caused by normal wear and tear, accident, mishap, untrained operators, or improper or unintended use. The owner has the obligation of performing routine care and maintenance duties as stated in Stellar's written instructions, recommendations, and specifications. Any damage resulting from owner/operator failure to perform such duties shall void the coverage of this warranty. The owner will pay the cost of labor and supplies associated with routine maintenance.

The only remedies the owner has in connection with the breach or performance of any warranty on the Stellar product specified are those set above. In no event will Stellar, the Stellar distributor/dealer, or any company affiliated with Stellar be liable for business interruptions, costs of delay, or for any special, indirect, incidental, or consequential costs or damages. Such costs may include, but are not limited to, loss of time, loss of revenue, loss of use, wages, salaries, commissions, lodging, meals, towing, hydraulic fluid, or any other incidental cost.

All products purchased by Stellar from outside vendors shall be covered by the warranty offered by that respective manufacturer only. Stellar does not participate in, or obligate itself to, any such warranty.

Stellar reserves the right to make changes in design or improvement upon its products without imposing upon itself the same upon its products theretofore manufactured.

This warranty will apply to all Stellar Cranes, Stellar Hooklift Hoists, Stellar Cable Hoists, Stellar Container Carriers, Stellar Service Trucks, Stellar X-Tra-Lift Systems, and Stellar Tarper Systems shipped from Stellar's factory after January 1st, 2010. The warranty is for the use of the original owner only and is not transferable without prior written permission from Stellar.

THIS WARRANTY IS EXPRESSLY IN LIEU OF ANY OTHER WARRANTIES, EXPRESS OR IMPLIED, INCLUDING ANY WARRANTY OF MERCHANTABILITY OR FITNESS FOR A PARTICULAR PURPOSE. REMEDIES UNDER THIS WARRANTY ARE LIMITED TO THE PROVISION OF MATERIAL AND SERVICES, AS SPECIFIED HEREIN. STELLAR INDUSTRIES, INC. IS NOT RESPONSIBLE FOR INCIDENTAL OR CONSEQUENTIAL DAMAGES.

Revision Date: February 2010

Document Number: 37040