



WEBSITE <http://biz.LGservice.com>
E-MAIL <http://www.LGService.com/techsup.html>

Room Air Conditioner

SERVICE MANUAL

**MODEL: LWJ0561ACG
LWJ0561ACP/AAG**

CAUTION

- BEFORE SERVICING THE UNIT, READ THE "SAFETY PRECAUTIONS" IN THIS MANUAL.
- ONLY FOR AUTHORIZED SERVICE PERSONNEL.

CONTENTS

1. PREFACE	3
1.1 FEATURES	3
1.2 SPECIFICATIONS	3
1.3 LOCATIONS OF CONTROLS	4
1.4 SAFETY PRECAUTIONS	4
1.5 INSULATION RESISTANCE TEST	4
2. DISASSEMBLY INSTRUCTIONS	5
2.1 MECHANICAL PARTS	5
2.1.1 FRONT GRILLE	5
2.1.2 CABINET	5
2.1.3 CONTROL BOARD	5
2.2 AIR HANDLING PARTS	6
2.2.1 AIR GUIDE UPPER	6
2.2.2 ORIFICE, TURBO FAN AND FAN	6
2.2.3 MOTOR	7
2.2.4 AIR GUIDE	7
2.3 ELECTRICAL PARTS	7
2.3.1 OVERLOAD PROTECTOR	7
2.3.2 COMPRESSOR	7
2.3.3 CAPACITOR	8
2.3.4 THERMOSTAT	8
2.3.5 ROTARY SWITCH	8
2.3.6 POWER CORD	8
2.4 REFRIGERANT CYCLE	8
2.4.1 CONDENSER	8
2.4.2 EVAPORATOR	9
2.4.3 CAPILLARY TUBE	9
3. INSTALLATION	11
3.1 SELECT THE BEST LOCATION	11
3.2 CHECK OF INSTALLATION	11
3.3 HOW TO DRAIN	11
3.4 HOW TO INSTALL	12
4. TROUBLESHOOTING GUIDE	12
4.1 OUTSIDE DIMENSION	12
4.2 PIPING SYSTEM	13
4.3 TROUBLESHOOTING GUIDE	14
5. SCHEMATIC DIAGRAM	19
5.1 CIRCUIT DIAGRAM	19
6. EXPLODED VIEW	21
7. SERVICE PARTS LIST	22

1. PREFACE

This service manual provides various service information, including the mechanical and electrical parts, etc. This room air conditioner was manufactured and assembled under a strict quality control system. The refrigerant is charged at the factory. Be sure to read the safety precautions prior to servicing the unit.

1.1 FEATURES

- DESIGNED FOR COOLING ONLY
- POWERFUL AND INCREDIBLE COOLING
- TOP-DOWN CHASSIS FOR THE SIMPLE INSTALLATION AND SERVICE
- BUILT-IN ADJUSTABLE THERMOSTAT
- WASHABLE ONE-TOUCH FILTER
- COMPACT SIZE

1.2 SPECIFICATIONS

ITEMS	MODELS	LWJ0561ACG, LWJ0561ACP/AAG
COOLING CAPACITY (BTU/h)		5,000
POWER SUPPLY (Phase, V, Hz)		1Ø, 220-240V, 50HZ
INPUT (W)		625
OPERATING CURRENT (AMP.)		2.8
REFRIGERANT CONTROL		CAPILLARY TUBE
REFRIGERANT CHARGE (R-22)		200g
INSIDE FAN		TURBO
OUTSIDE FAN		PROPELLER FAN WITH SLINGER RING
AIR DISCHARGE		2-WAY (RIGHT AND LEFT)
CHASSIS		TOP-DOWN
PROTECTOR		<ul style="list-style-type: none"> • OVERLOAD PROTECTOR FOR COMPRESSOR • INTERNAL PROTECTOR FOR FAN MOTOR
TEMPERATURE CONTROL		THERMOSTAT
ROTARY SWITCH		5 STEP (LOW FAN, HIGH FAN, OFF, HIGH COOL, LOW COOL)
FAN MOTOR		4 POLES, 18W

- **NOTE:** Specifications are subject to minor change without notice for further improvement.

1.3 LOCATIONS OF CONTROLS

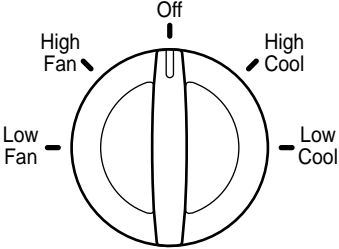
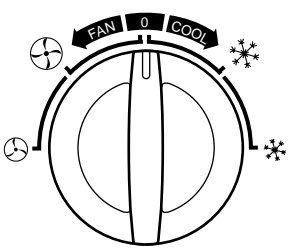
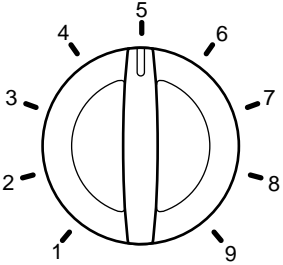
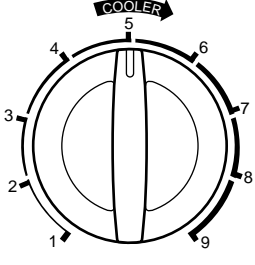
<p style="text-align: center;">Operation</p> 	<p style="text-align: center;">Operation</p> 	<p>Off (0) : Turns air conditioner off.</p> <p>High Fan (⊕) : High speed fan operation without cooling.</p> <p>Low Fan (⊗) : Low speed fan operation without cooling.</p> <p>High Cool (❄) : Cooling with high speed fan operation.</p> <p>Low Cool (*) : Cooling with low speed fan operation.</p>
<p style="text-align: center;">Thermostat</p> 	<p style="text-align: center;">Thermostat</p> 	<p>This automatically controls the temperature of the indoor air.</p> <p>Turn the knob so that the arrow points to the larger marks for greater cooling. Point the arrow to the smaller marks for more moderate cooling. (i.e. the higher the number, the greater the cooling)</p>

⚠ CAUTION : After switching the air conditioner from Cool to Off (0) or Fan, wait at least 3 minutes before switching it back to Cool.

1.4 SAFETY PRECAUTIONS

1. When servicing, set the ROTARY SWITCH to Off (0) and unplug the power cord.
2. Observe the original lead dress.
If a short circuit is found, replace all parts which have been overheated or damaged by the short circuit.
3. After servicing, make an insulation resistance test to prevent the customer from being exposed to shock hazards.

1.5 INSULATION RESISTANCE TEST

1. Unplug the power cord and connect a jumper between 2 pins (black and white).
2. The grounding conductor (green or green and yellow) is to be open.
3. Measure the resistance value with an ohm meter between the jumpered lead and each exposed metallic part on the equipment at all position [except Off (0)] of the ROTARY SWITCH.
4. The value should be over 1 MΩ.

2. DISASSEMBLY INSTRUCTIONS

2.1 MECHANICAL PARTS

2.1.1 FRONT GRILLE

1. Disconnect the unit from the power source.
2. Remove the two knobs by pulling them off.
Using a screwdriver, remove the screw that secures the front grille to control board.
(See Figure 1)
3. Push the front grille up from the bottom.
Pull the top of the front grille away from the cabinet as the top tabs lift out of their slots.
(See Figure 2)
4. Replace the grille by placing the tabs in the slots and push the grille until it snaps into place.

Figure 1

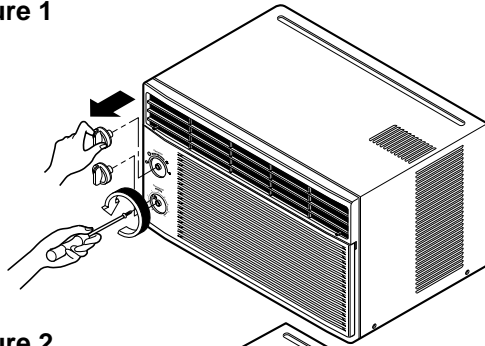

Figure 2

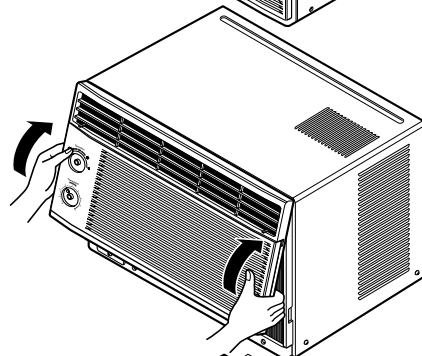

Figure 3

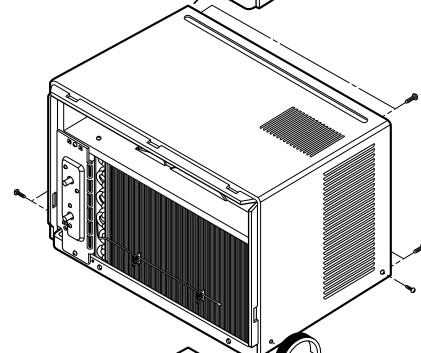

Figure 4

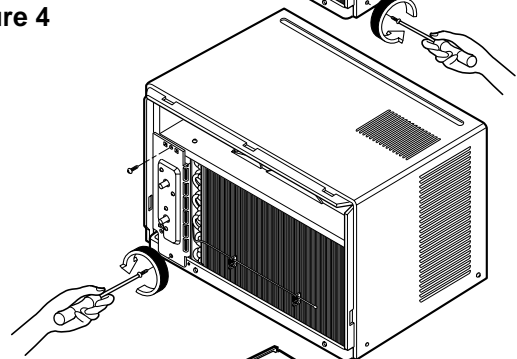
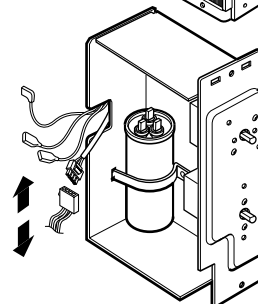

Figure 5



2.1.2 CABINET

1. Disconnect the unit from the power source.
2. Remove the front grille. (Refer to Section 2.1.1)
3. Remove 9 screws that secure the cabinet to the base and condenser. (See Figure 3)
4. Lift the cabinet from the unit.
5. Re-install by referring to the procedures above.

2.1.3 CONTROL BOARD

1. Disconnect the unit from the power source.
2. Remove the front grille. (Refer to Section 2.1.1)
3. Remove the cabinet. (Refer to Section 2.1.2)
4. Remove 2 screws that secure the control board to base pan and air guide. (See Figure 4)
5. Pull the control board toward yourself.

NOTE : Controls, wires, and capacitor are now accessible for servicing. Discharge the capacitor before servicing.
(Refer to section 2.3.3)

6. Disconnect one housing terminal and 3 wires for the fan motor and compressor. (See Figure 5)
7. Re-install components by referring to procedures above. (Refer to wiring diagram on page 19 in this manual or inside control board.)

2.2 AIR HANDLING PARTS

2.2.1 AIR GUIDE UPPER

1. Disconnect the unit from the power source.
2. Remove the front grille. (Refer to Section 2.1.1)
3. Remove the cabinet. (Refer to Section 2.1.2)
4. Remove the control board.
(Refer to Section 2.1.3)
5. Remove 2 screws that secure the brace to air guide upper and shroud. (See Figure 6)
6. Remove 2 screws that secure the air guide upper to air guide lower. (See Figure 6)
7. Lift air guide upper upward.
8. Re-install by referring to the procedures above.

Figure 6

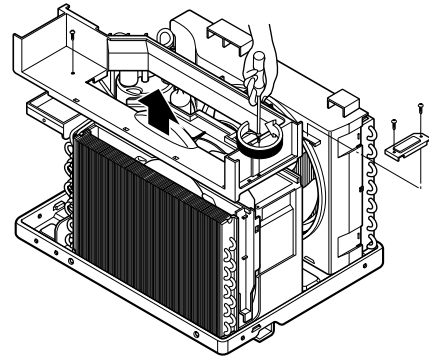

Figure 7

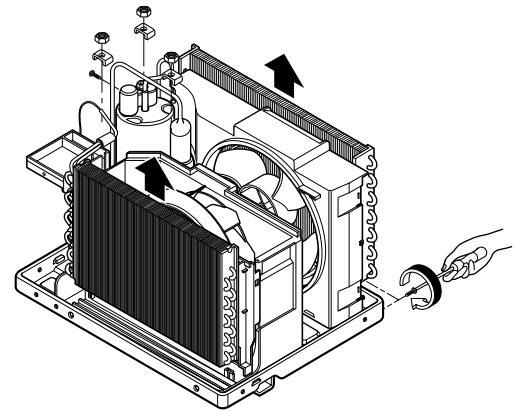
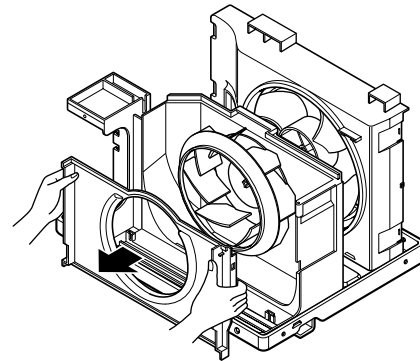

Figure 8



2.2.2 ORIFICE, TURBO FAN AND FAN

1. Disconnect the unit from the power source.
2. Remove the front grille. (Refer to Section 2.1.1)
3. Remove the cabinet. (Refer to Section 2.1.2)
4. Remove the control board.
(Refer to Section 2.1.3)
5. Remove the air guide upper.
(Refer to Section 2.2.1)
6. Remove 2 screws that secure the base pan to condenser. (See Figure 7)
7. Remove 2 screws that secures the shroud to channel of condenser.
8. Press the snap area of shroud with your thumbs.
This allows you to remove it from the condenser.
9. Lift the compressor upward with the evaporator and condenser. (See Figure 7)
10. Remove the orifice by pushing the snap area of the air guide blower. (See Figure 8)
11. Remove the clamp springs which are clamped to the boss of fan and turbo fan by hand plier. (See Figure 9)
12. Pull the fan and turbo fan outward.
13. Remove the shroud.
14. Re-install by referring to the procedures above.

Figure 9

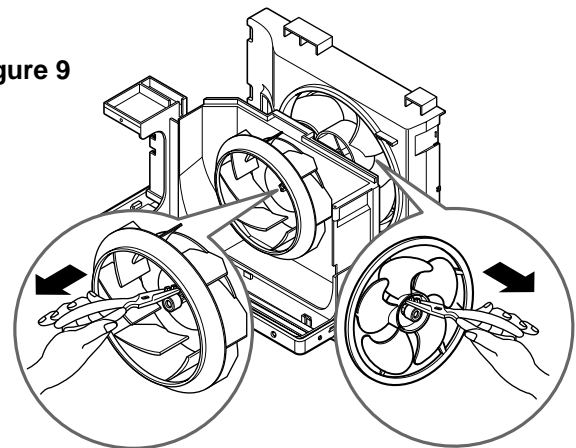

2.2.3 MOTOR

1. Disconnect the unit from the power source.
2. Remove the front grille. (Refer to Section 2.1.1)
3. Remove the cabinet. (Refer to Section 2.1.2)
4. Remove the control board. (Refer to Section 2.1.3)
5. Remove the air guide upper. (Refer to Section 2.2.1)
6. Remove the compressor, turbo fan, fan and shroud. (Refer to Section 2.2.2)
7. Remove 2 screws that secure the motor to the motor. (See Figure 10)
8. Remove the motor.
9. Re-install by referring to the procedures above.

Figure 10

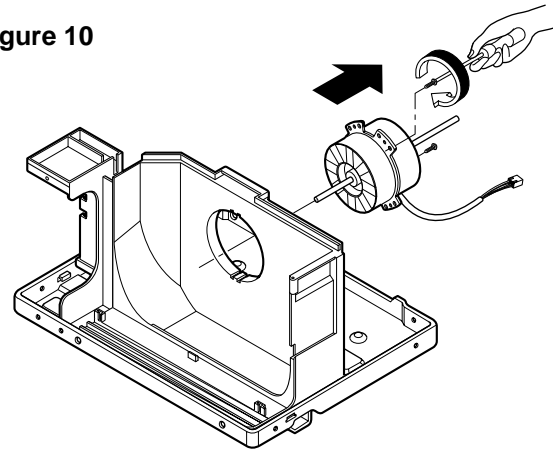

2.2.4 AIR GUIDE

1. Disconnect the unit from the power source.
2. Remove the front grille. (Refer to Section 2.1.1)
3. Remove the cabinet. (Refer to Section 2.1.2)
4. Remove the control board. (Refer to Section 2.1.3)
5. Remove the air guide upper. (Refer to Section 2.2.1)
6. Remove the compressor, turbo fan, fan and shroud. (Refer to Section 2.2.2)
7. Remove the motor. (Refer to Section 2.2.3)
8. Remove 2 screws that secure the air guide to the base pan. (See Figure 11)
9. Push the air guide backward and lift it upward. (See Figure 11)
10. Re-install by referring to the procedures above.

Figure 11

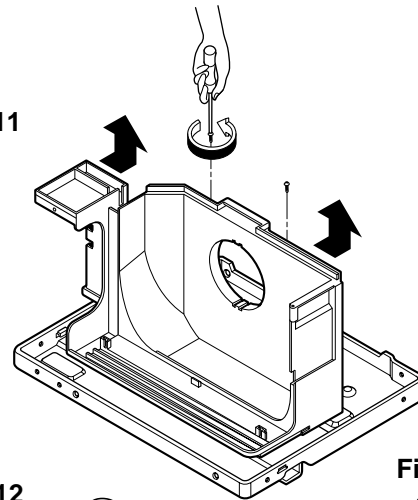

Figure 12

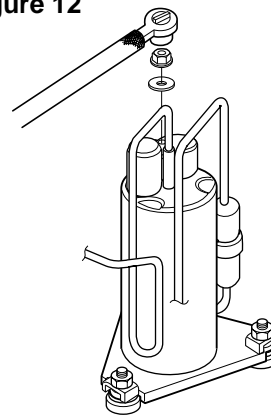
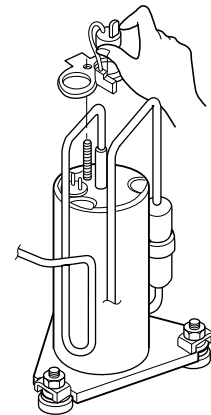

Figure 13



2.3 ELECTRICAL PARTS

2.3.1 OVERLOAD PROTECTOR

1. Remove the front grille and cabinet. (Refer to Section 2.1)
2. Remove the nut which fastens the terminal cover.
3. Remove the terminal cover.
4. Remove all the leads from the overload protector.
5. Remove the overload protector.
6. Re-install the components by referring to the removal procedure above. (See Figure 12 and 13)

2.3.2 COMPRESSOR

1. Remove the front grille and cabinet. (Refer to Section 2.1)
2. Discharge the refrigerant by using a refrigerant recovery system.
3. Remove the overload protector. (Refer to Section 2.3.1)
4. After discharging the unit completely, unbrace the suction and discharge pipes at the compressor connections.
5. Remove 3 nuts which fasten the compressor.
6. Remove the compressor.
7. Re-install by referring to the removal procedure above. (See Figure 14)

Figure 14

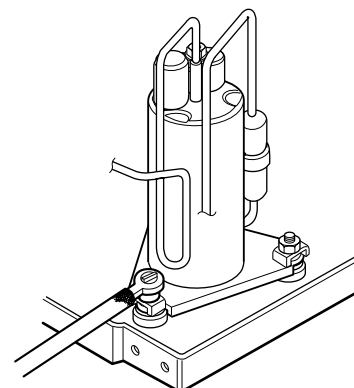

2.3.3 CAPACITOR

1. Remove the cabinet. (Refer to Section 2.1.2)
2. Remove the control board. (Refer to Section 2.1.3)
3. Discharge the capacitor by placing a 20 K Ω resistor across the capacitor terminals.
4. Remove the screw which fastens the capacitor clamp.
5. Remove all the leads of capacitor terminals.
6. Re-install the components by referring to the removal procedure above. (See Figure 15)

Figure 15

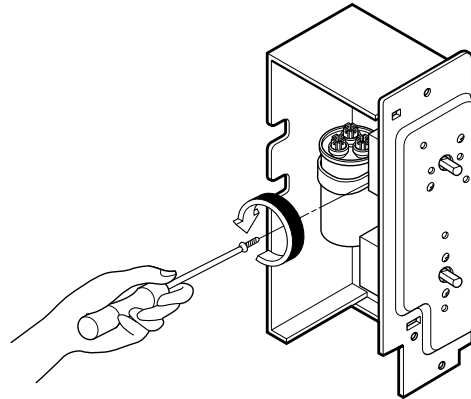

2.3.4 THERMOSTAT

1. Remove the cabinet. (Refer to Section 2.1.2)
2. Remove the control board. (Refer to Section 2.1.3)
3. Remove 2 screws which fasten the thermostat. (See Figure 16)
4. Remove all the leads of the thermostat terminals.
5. Remove the thermostat.
6. Re-install the components by referring to the removal procedure above.

Figure 16

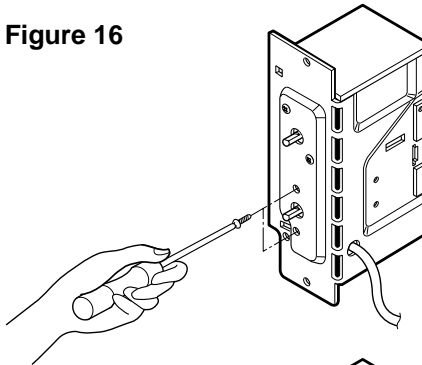

2.3.5 ROTARY SWITCH

1. Remove the cabinet. (Refer to Section 2.1.2)
2. Remove the control board. (Refer to Section 2.1.3)
3. Remove 2 screws which fasten the rotary switch. (See Figure 17)
4. Remove all the leads of the rotary switch terminals.
5. Remove the rotary switch.
6. Re-install the components by referring to the removal procedure above.

Figure 17

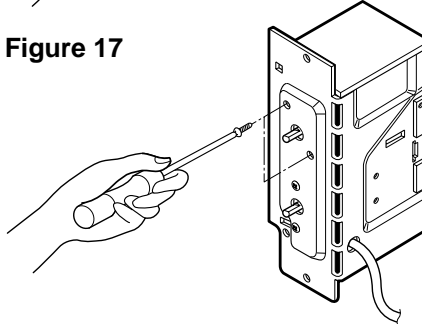

2.3.6 POWER CORD

1. Disconnect the unit from source of power.
2. Remove the front grille. (Refer to Section 2.1.1)
3. Remove the cabinet. (Refer to Section 2.1.2)
4. Remove a screw that secures control board to base pan. (Refer to Section 2.1.3)
5. Pulls the control board toward you.
6. Disconnect the 2 receptacles and remove the grounding screw.
7. Remove a screw securing the clip with cord to the control board. (See Figure 18)
8. Pull the power cord.
9. Re-install by referring to procedures above.

Figure 18

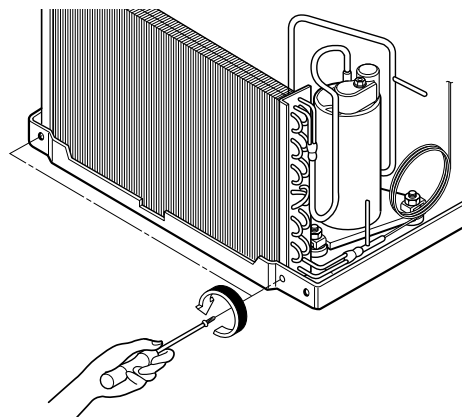

2.4 REFRIGERANT CYCLE

2.4.1 CONDENSER

1. Remove the cabinet. (Refer to Section 2.1.2)
2. Discharge the refrigerant by using a refrigerant recovery system.
3. Remove the air guide. (Refer to Section 2.2.1)
4. Remove 2 screws which fasten the condenser.
5. After discharging the refrigerant completely, unbraid the interconnecting tube at the condenser connections.
6. Remove the condenser.
7. Re-install by referring to the procedures above.

2.4.2 EVAPORATOR

1. Remove the cabinet. (Refer to section 2.1.2)
2. Discharge the refrigerant by using a refrigerant recovery system.
3. Remove the air guide upper. (Refer to Section 2.2.1)
4. After discharging the refrigerant completely, unbrazed the interconnecting tube at the evaporator connections.
5. Remove the evaporator.
6. Re-install by referring to the procedures above.

2.4.3 CAPILLARY TUBE

1. Remove the cabinet. (Refer to section 2.1.2)
2. Discharge the refrigerant by using a refrigerant recovery system.
3. Remove the air guide upper. (Refer to Section 2.2.1)
4. After discharging the refrigerant completely, unbrazed the interconnecting tube of the capillary tube.
5. Remove the capillary tube.
6. Re-install by referring to the procedures above.

NOTES

Replacement of the refrigeration cycle.

1. When replacing the refrigerating cycle, be sure to discharge the refrigerant by using a refrigerant recovery system.
2. After discharging the unit completely, remove the desired components, and unbrazed the pinch-off tubes.
3. Solder service valves into the pinch-off tube ports, leaving the valves open.
4. Solder the pinch-off tubes with service valves.
5. After completing the above procedures, the valve must be closed and left in place on the system for any subsequent procedures.
6. Evacuate as follows:
 - 6-1. Connect the vacuum pump, as illustrated in figure 20A.
 - 6-2. Start the vacuum pump. Slowly open manifold valves A and B with two full turns counter-clockwise and leave the valves closed. The vacuum pump is now pulling through valves A and B up to valve C by means of manifold and the entire system.

CAUTION : If high vacuum equipment is used, just crack valves A and B for a few minutes, then open slowly with the two full turns counter-clock-

wise. This will keep oil from foaming and being drawn into the vacuum pump.

- 6-3. Operate the vacuum pump for 20 to 30 minutes, until 600 micron vacuum is obtained. Close valves A and B and observe vacuum gauge for a few minutes. A rise in pressure would indicate a possible leak or moisture remaining in the system. With valves A and B closed, stop the vacuum pump.
- 6-4. Remove the hose from the vacuum pump and place it on the charging cylinder. See figure 20B. Open valve C. Discharge the line at the manifold connection.
- 6-5. The system is now ready for final charging.
7. Recharge as follows:
 - 7-1. Rotary compressor systems are charged from the high-side. If the total charge cannot be put in the high-side, the balance will be put in the suction line through the access valve which is installed as the system is opened.
 - 7-2. Connect the charging cylinder as shown in figure 20B. With valve C open, discharge the hose at the manifold connection.
 - 7-3. Open valve A and allow the proper charge to enter the system. Valve B is still closed.
 - 7-4. If more charge is required, the high-side will not take it. Close valve A.
 - 7-5. With the unit running, open valve B and add the balance of the charge.
 - a. Do not add the liquid refrigerant to the low-side.
 - b. Watch the low-side gauge, allow pressure to rise to 30 lbs.
 - c. Turn off valve B and allow the pressure to drop.
 - d. Repeat steps B and C until the balance of the charge is in the system.
 - 7-6. When the unit is operating correctly, use the pinch-off tool with the unit still running and the clamp on the pinch-off tube. Using a tube cutter, cut the pinch-off tube about 2 inches from the pinch-off tool. Use sil-fos solder and solder the pinch-off tube closed. Turn off the unit, allow setting for a while and then test the leakage of the pinch-off connection.

Equipment needed: Vacuum pump, charging cylinder, manifold gauge, brazing equipment, pinch-off tool capable of making a vapor proof seal, leak detector, tubing cutter, hand tools to remove components and service valve.

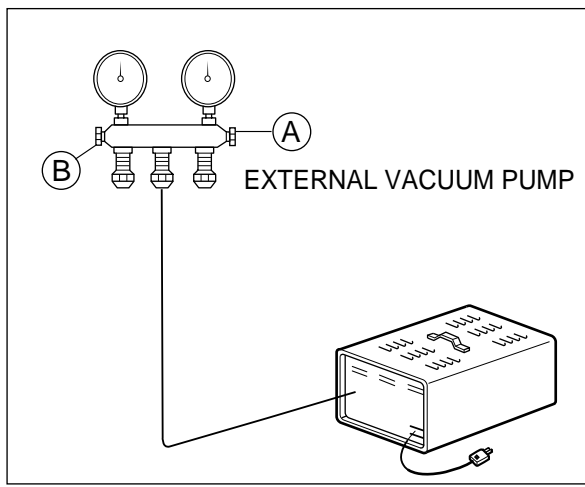
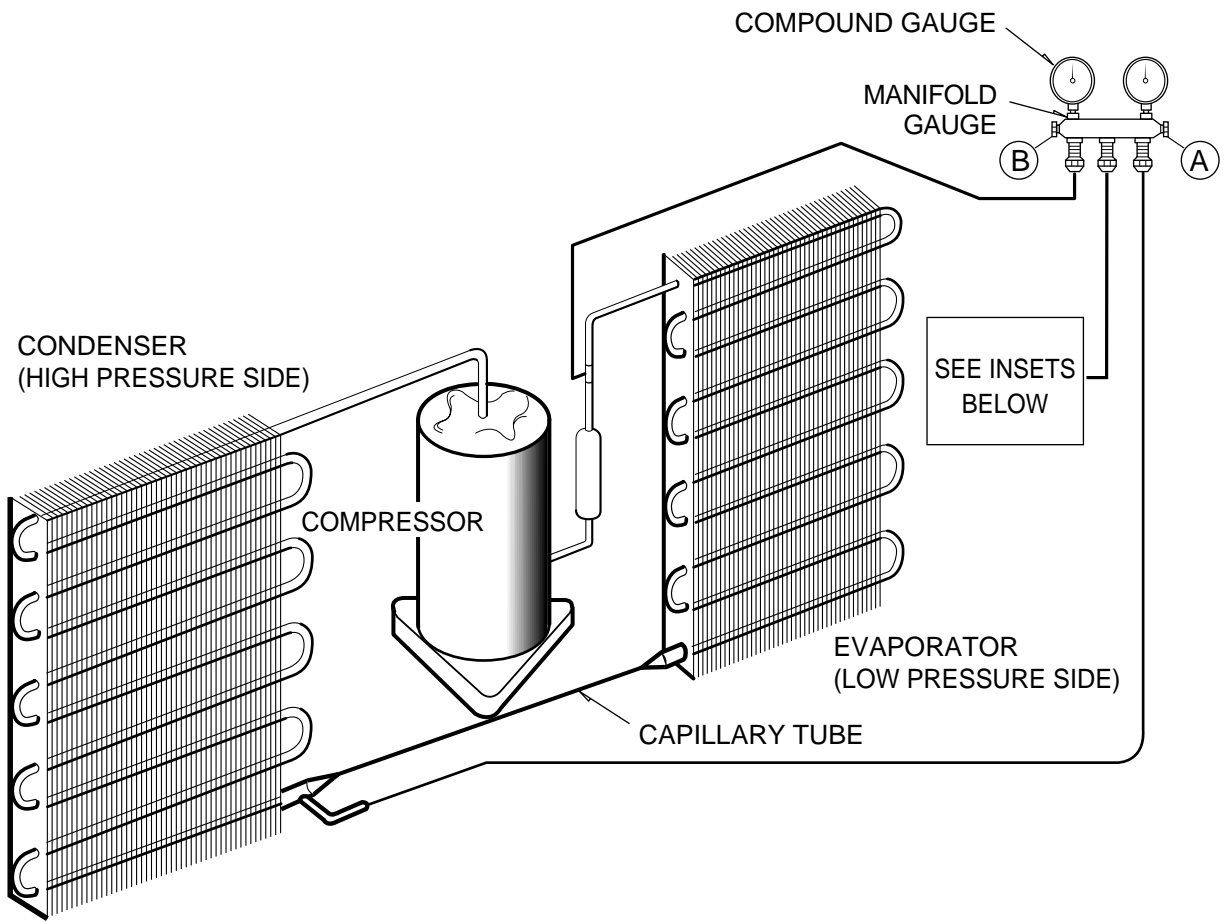

Figure 20A-Pulling Vacuum

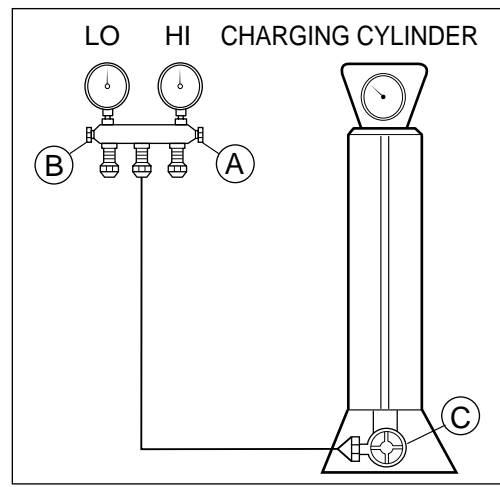

Figure 20B-Charging

3. INSTALLATION

This air conditioner is designed with a button-down chassis so that it can be installed simply in a window.

3-1. SELECT THE BEST LOCATION

1. To prevent vibration and noise, make sure the unit is installed securely and firmly.
2. Install the unit where the sunlight does not shine directly on the unit.
3. The outside of the cabinet must extend outward for at least 10" and there should be no obstacles, such as a fence or wall, within 20" from the back of the cabinet because it will prevent heat radiation of the condenser.

Restriction of outside air will greatly reduce the cooling efficiency of the air conditioner.

CAUTION

All side louvers of the cabinet must remain exposed to the outside of the structure.

4. Install the unit a little slanted so the back is slightly lower than the front (about 1/4"). This will force condensed water to the outside.
5. Install the unit with the bottom about 30"~60" above the floor level.

3-2. CHECK OF INSTALLATION

The setting conditions must be checked prior to initial starting.

The under mentioned items are especially important checking points when the installation is finished.

1. Grounding wire (Green or Green Yellow) is provided in the power cord. The green wire must be grounded.
2. Connect to a single-outlet 15AMP circuit.
3. To avoid vibration or noise, make sure the air conditioner is installed securely.
4. Avoid placing furniture or drapeies in front of the air inlet and outlet.

3.3 HOW TO DRAIN

(When using drain pipe)

The air conditioner must be level or titled slightly to the outside for proper water drainage. On exceptionally hot and humid days the air conditioner may drain condensation water through overflow. If the air conditioner is used in hot and a high humidity zone, exchange the ① HOLE RUBBER for the ② DRAIN PIPE. (See figure 22, figure 23)

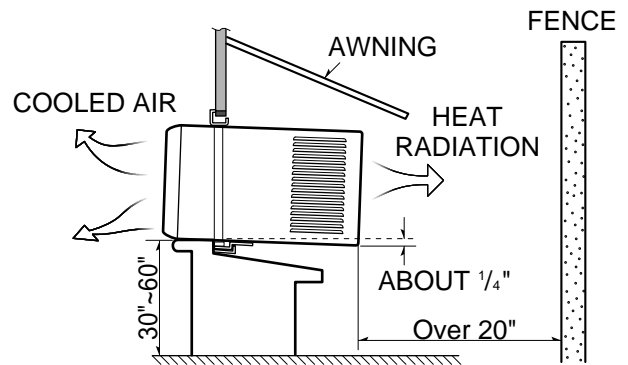

Figure 21

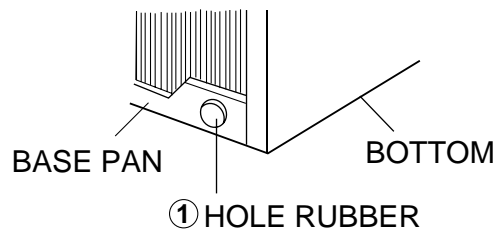

Figure 22

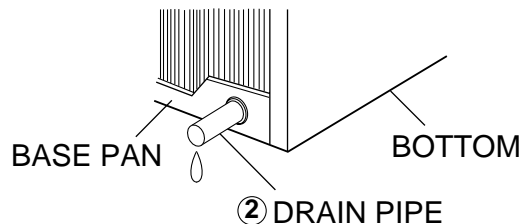

Figure 23

3.4 HOW TO INSTALL

• WHEN USING GASKET

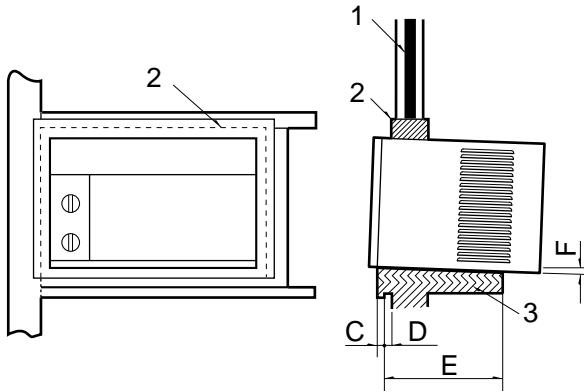

Figure 24

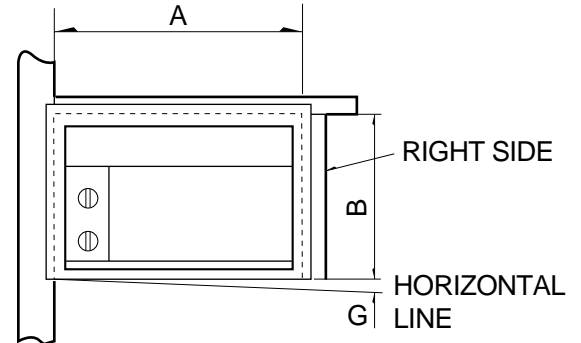

Figure 25

1. WINDOW (A - WIDTH, B - HEIGHT)
2. GASKET
3. WALL

A	B	C	D	E	F	G
487mm (19 3/16")	324mm (12 3/4")	30mm (1 1/16")	0~25mm (0~1")	OVER 240mm (9 15/32")	5~10mm (3/16"~3/8")	-5~5mm (-3/16"~3/16")

4. TROUBLE SHOOTING GUIDE

4.1 OUTSIDE DIMENSION (unit : mm)

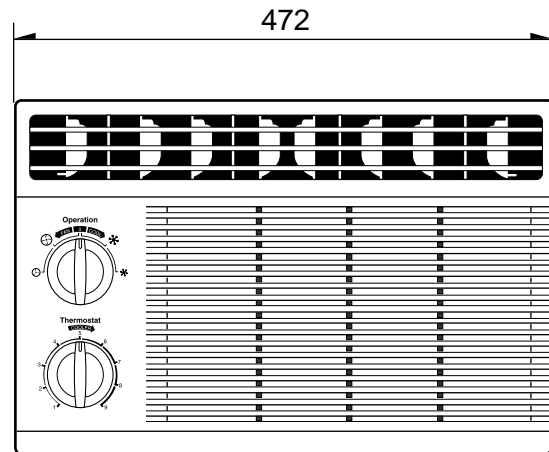
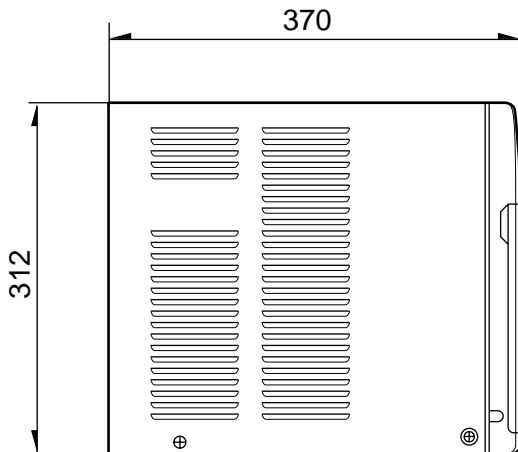

4.2 PIPING SYSTEM

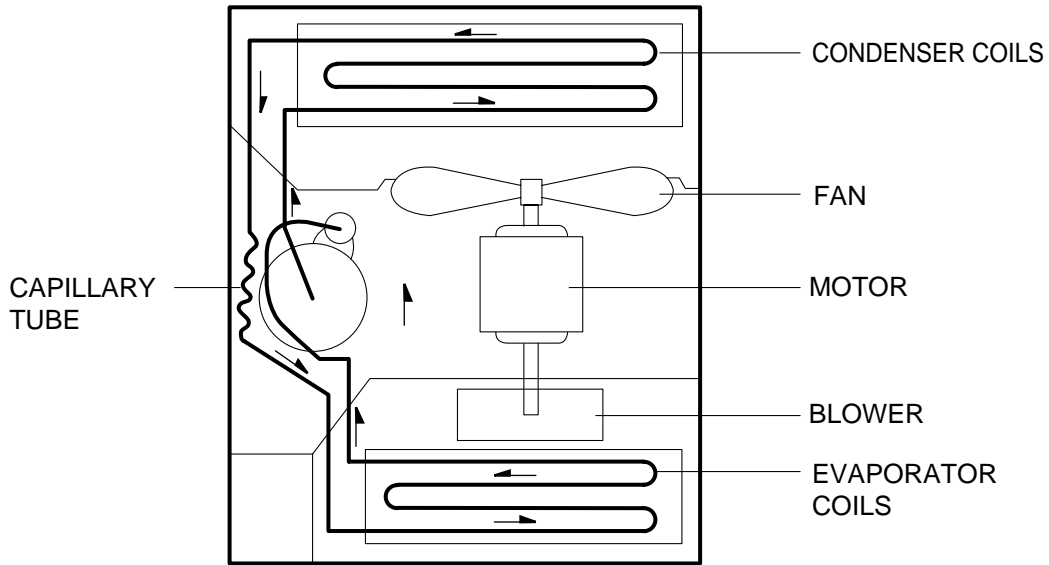

Following is a brief description of the important components and their function in what is called the refrigeration system. Reference should be made to Figure 26 to follow the refrigerating cycle and the flow of the refrigerant in the cooling cycle.

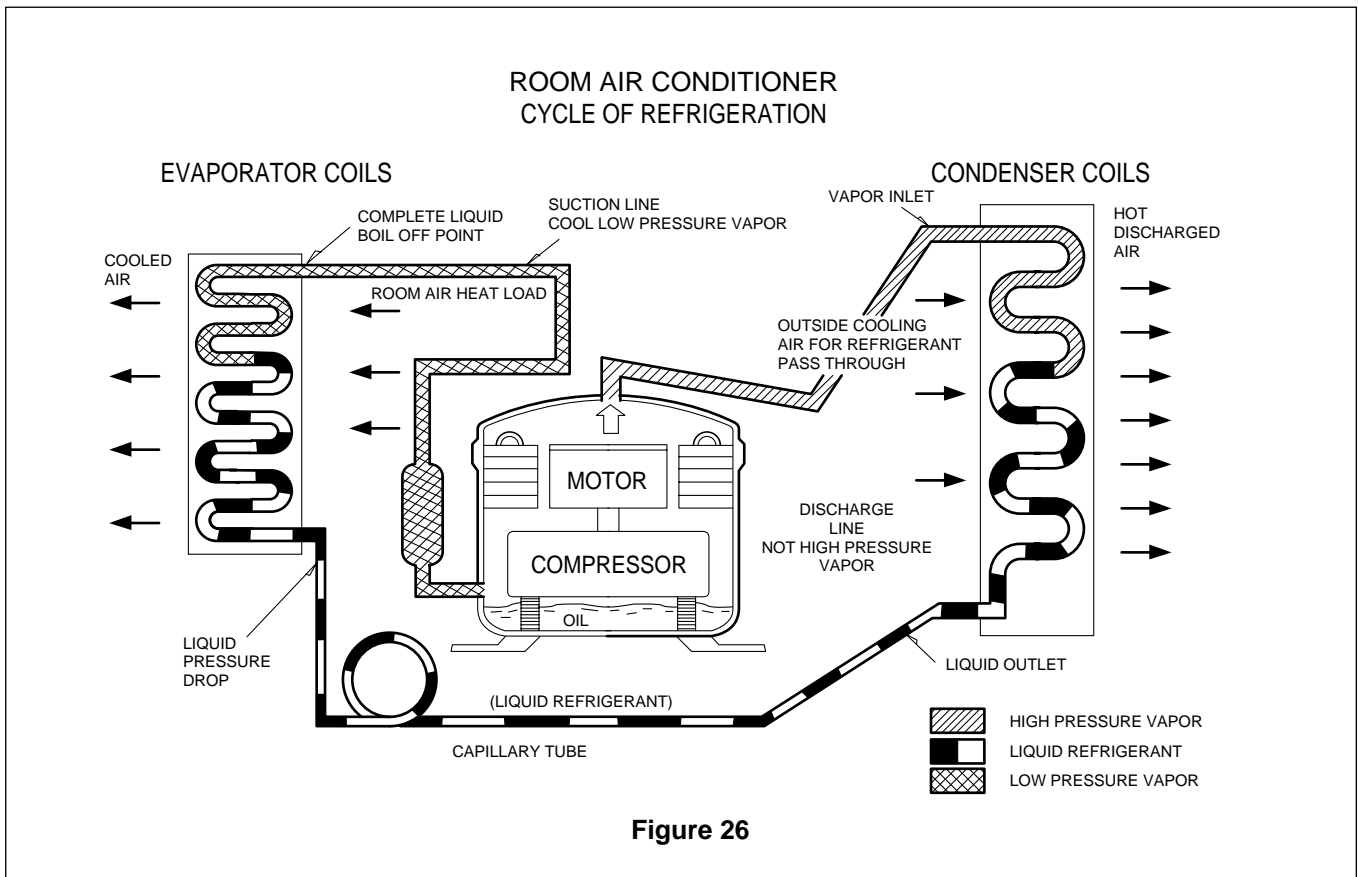

4.3 TROUBLESHOOTING GUIDE

In general, possible trouble is classified in two kinds.

The one is called **Starting Failure** which is caused from an electrical defect. The other is **Ineffective Air Conditioning** caused from a defect in the refrigeration circuit and improper application.

Unit is running but cooling is ineffective.

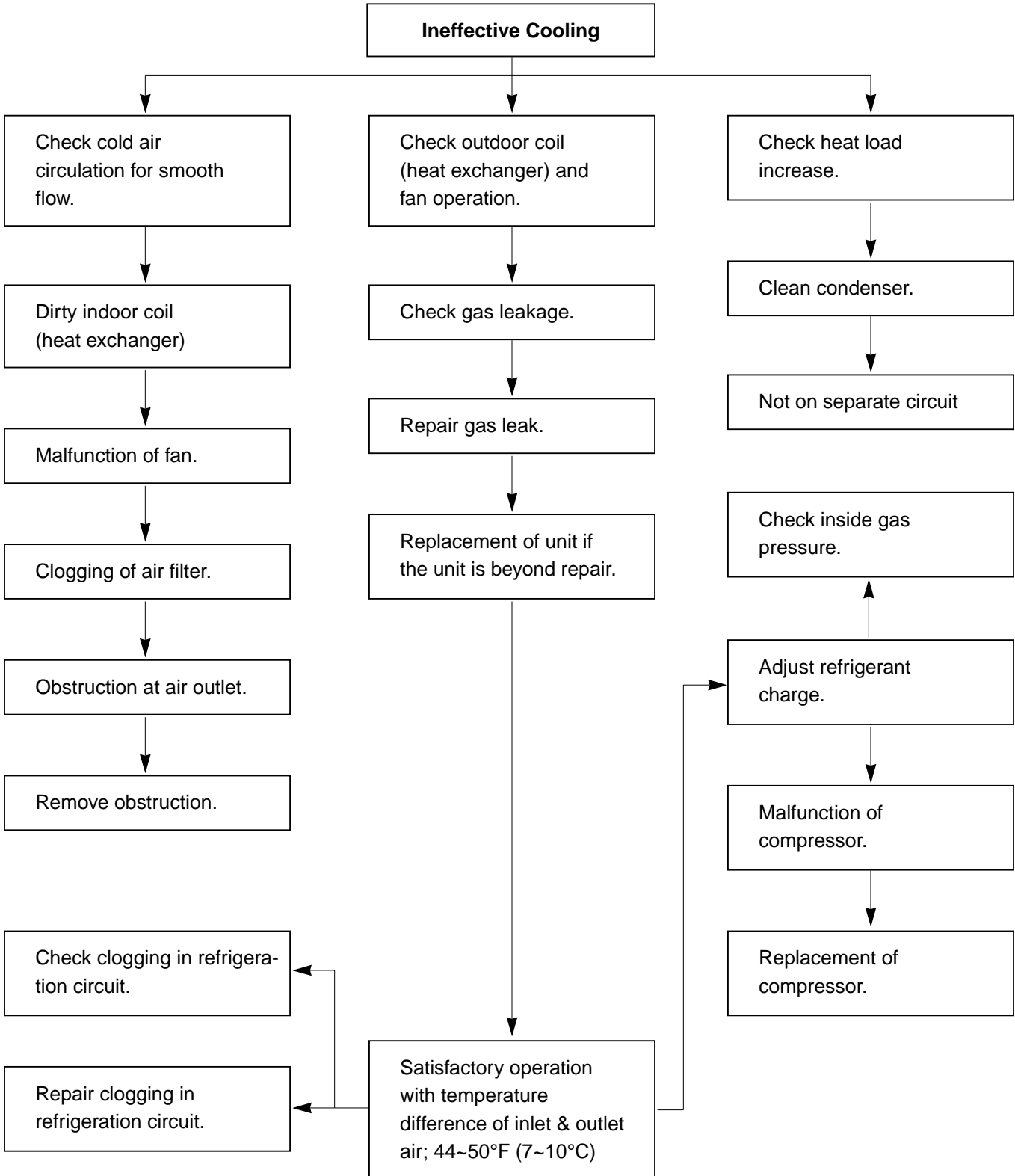

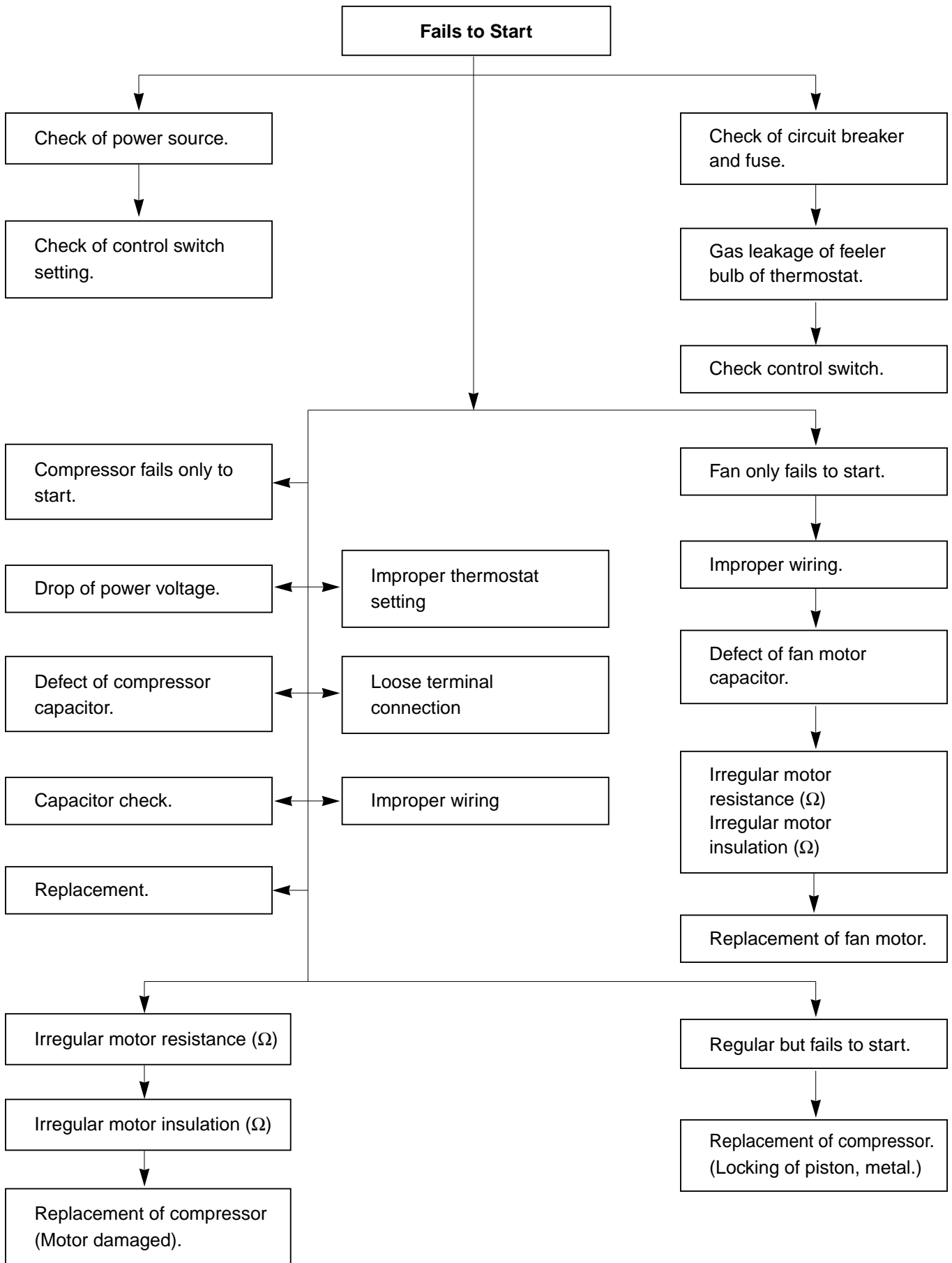

ROOM AIR CONDITIONER VOLTAGE LIMITS

NAME PLATE RATING	MINIMUM	MAXIMUM
220V~240V	198V	264V

COMPLAINT	CAUSE	REMEDY
Fan motor will not run.	No power	Check voltage at outlet. Correct if none.
	Power supply cord	Check voltage to rotary switch. If none, check power supply cord. Replace cord if circuit is open.
	Rotary switch	Check switch continuity. Refer to wiring diagram for terminal identification. Replace switch if defective.
	Wire disconnected or connection loose	Connect wire. Refer to wiring diagram for terminal identification. Repair or replace loose terminal.
	Capacitor. (Discharge capacitor before testing.)	Test capacitor. Replace if not within $\pm 10\%$ of manufacturer's rating. Replace if shorted, open, or damaged.
	Will not rotate	Fan blade hitting shroud or blower wheel hitting scroll. Re-align assembly. Units using slinger ring condenser fans must have 0.22~0.25 inch clearance to the base. If it is the base, shim up the bottom of the fan motor with mounting screw(s). Check fan motor bearings; if motor shaft will not rotate, replace the motor.
Fan motor runs.	Revolves on overload.	Check voltage. See limits on this page. If not within limits, call an electrician. Test capacitor. Check bearings. Does the fan blade rotate freely? If not, replace fan motor. Pay attention to any change from high speed to low speed. If the speed does not change, replace the motor.

COMPLAINT	CAUSE	REMEDY
Fan motor noise.	Fan	If cracked, out of balance, or partially missing, replace it.
	Blower	If cracked, out of balance, or partially missing, replace it.
	Loose set screw	Tighten it.
	Worn bearings	If knocking sounds continue when running or loose, replace the motor. If the motor hums or noise appears to be internal while running, replace motor.
Compressor will not run, fan motor runs.	Voltage	Check voltage. See the limits on the preceding page. If not within limits, call an electrician.
	Wiring	Check the wire connections; if loose, repair or replace the terminal. If the wires are disconnected, refer to wiring diagram for identification, and replace the wires. Check the wire connections; If not according to the wiring diagram, correct the connections.
	Rotary Switch	Check for continuity, refer to the wiring diagram for terminal identification. Replace the switch if the circuit is open.
	Thermostat	Check the position of knob. If not at the coldest setting, advance the knob to this setting and restart the unit.
		Check the continuity of the thermostat. Replace the thermostat if the circuit is open.
	Capacitor (discharge capacitor before servicing.)	Check the capacitor. Replace if not within $\pm 10\%$ of manufacturer's rating, replace if shorted, open, or damaged.
	Compressor	Check the compressor for open circuit or ground. If open or grounded, replace the compressor.
	Overload	Check the compressor overload if externally mounted. Replace if open. (If the compressor temperature is high, remove the overload, cool and retest.)
Compressor cycles on overload.	Voltage	Check the voltage. See the limits on the preceding page. If voltage is not within these limits, call an electrician.
	Overload	Check overload, if externally mounted. Replace if open. (If the compressor temperature is high, remove the overload, cool, and retest.)

COMPLAINT	CAUSE	REMEDY
Compressor cycles on overload	Fan motor	If not running, determine the cause. Replace if required.
	Condenser air flow restriction	Remove the cabinet, inspect the interior surface of the condenser. If restricted, clean carefully with a vacuum cleaner (do not damage fins) or brush. Clean the interior base before re-assembling.
	Condenser fins (damaged)	If the condenser fins are closed over a large area on the coil surface, head pressures will increase, causing the compressor to cycle. Straighten the fins or replace the coil.
	Capacitor	Test the capacitor.
	Wiring	Check the terminals. If loose, repair or replace.
	Refrigeration system	Check the system for a restriction.
Insufficient cooling.	Air filter	If restricted, clean or replace.
	Unit undersized	Determine if the unit is properly sized for the area to be cooled.
Excessive noise.	Blower or fan	Check the set screw, or clamp. If loose or missing, correct. If the blower or fan is hitting scroll or shroud, rearrange the air handling parts.
	Copper tubing	Remove the cabinet and carefully rearrange the tubing not to contact the cabinet, compressor, shroud, and air guide.

5. SCHEMATIC DIAGRAM

5-1. CIRCUIT DIAGRAM

• MODEL : LWJ0561ACG

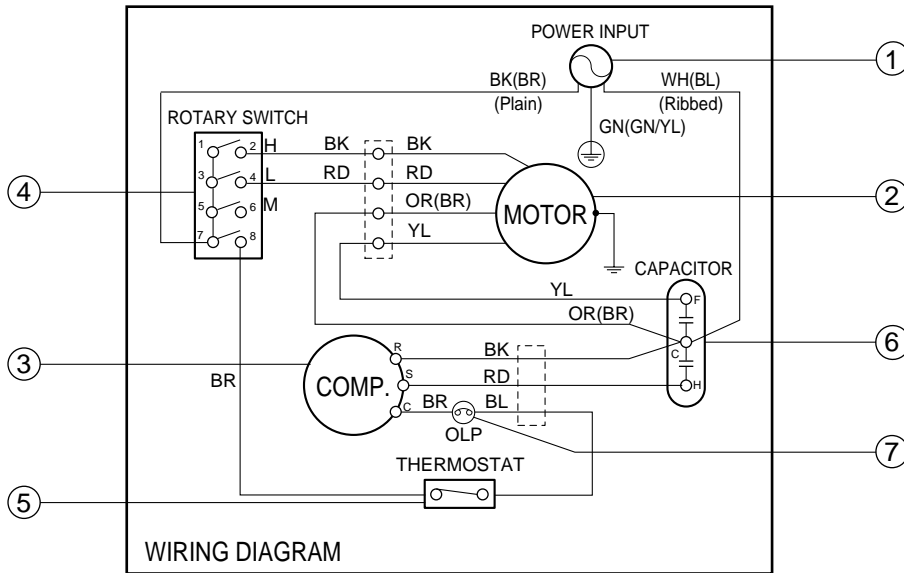

REF. NO	DESCRIPTION & NAME	Q'TY
1	POWER CORD ASSY	1
2	FAN MOTOR	1
3	COMPRESSOR	1
4	ROTARY SWITCH	1
5	THERMOSTAT	1
6	CAPACITOR	1
7	OVERLOAD PROTECTOR	1

• **MODEL : LWJ0561ACP/AAG**

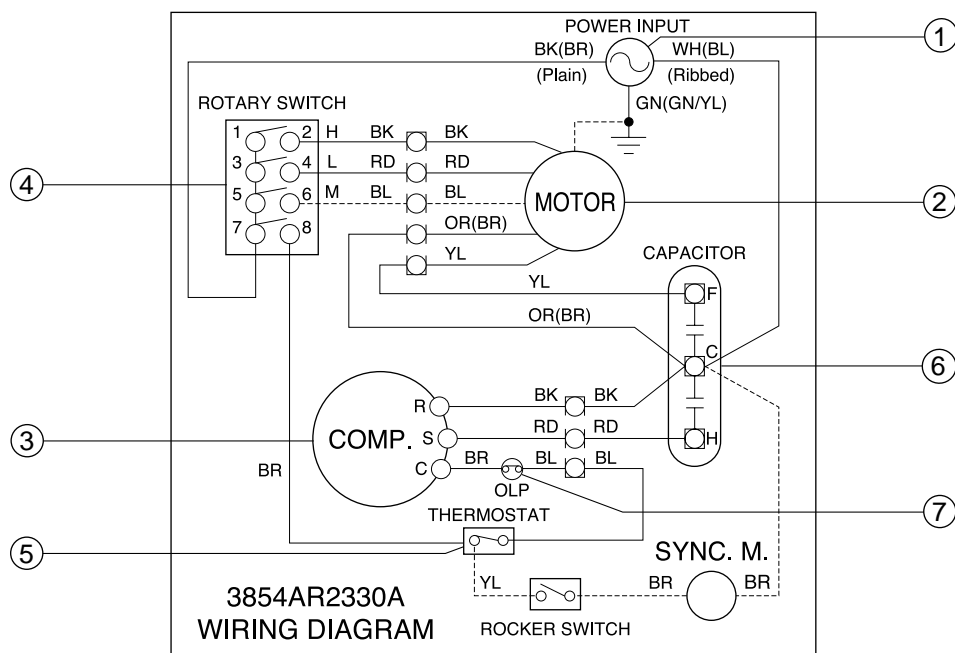

REF. NO	DESCRIPTION & NAME	Q'TY
1	POWER CORD ASSY	1
2	FAN MOTOR	1
3	COMPRESSOR	1
4	ROTARY SWITCH	1
5	THERMOSTAT	1
6	CAPACITOR	1
7	OVERLOAD PROTECTOR	1

6. EXPLODED VIEW

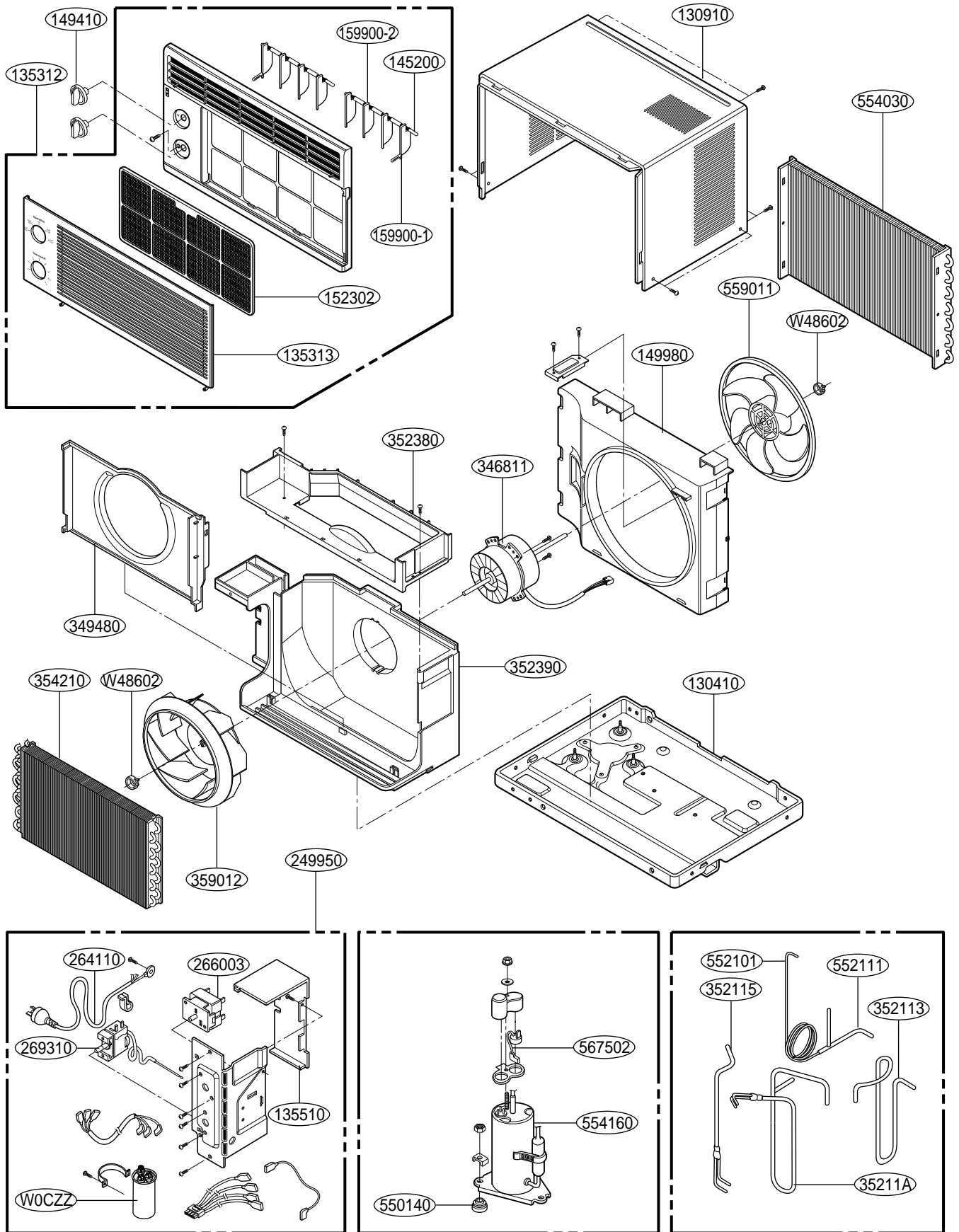

7. SERVICE PARTS LIST

LOCATION No.	DESCRIPTION	PART No.			REMARKS
		LWJ0561ACG	LWJ0561ACP	LWJ0561AAG	
130410	BASE ASSEMBLY, SINGLE	3041A10011G	3041A10011G	3041A10011G	R
130910	CABINET ASSEMBLY, SINGLE	3091A10020B	3091A10020B	3091A10020B	R
135312	GRILLE ASSEMBLY, FRONT(SINGLE)	3531AR1644C	3531AR1644L	3531AR1644Q	R
135313	GRILLE ASSEMBLY, INLET	3530AR1616A	3530AR1617A	3530AR1616A	R
135510	COVER	3550A20026A	3550A20026A		R
145200	LINK	4520AR3191A	4520AR3191A	4800A30003A	R
149410	KNOB ASSEMBLY	4941AR7315A	4941AR7315A	4941AR7315A	R
149980	SHROUD	4998A10008A	4998A10008A	4998A10008A	R
152302	FILTER(MECH), A/C	5231AR2148G	5231AR2148G	5231AR2148G	R
159900-1	VANE, VERTICAL	5990AR3190A	5990AR3190A	5990AR3190A	R
159900-2	VANE, VERTICAL	5990AR3190B	5990AR3190B	5990AR3190B	R
249950	CONTROL BOX ASSEMBLY, SINGLE	4995A20126B	4995A20126L	4995A20126L	R
264110	POWER CORD ASSEMBLY	2H01580M	3H02255E	3H02255E	R
266003	SWITCH, ROTARY	2H00154H	2H00154H	2H00154H	R
269310	THERMOSTAT ASSEMBLY	2H01109H	2H01109H	2H01109H	R
346811	MOTOR ASSEMBLY, SINGLE	4681A10002E	4681A10002E	4681A10002E	R
349480	ORIFICE	4948A10007A	4948A10007A	4948A10007A	R
352113	TUBE, DISCHARGE	5210A20511B	5210A20511B	5210A20511B	R
352115	TUBE ASSEMBLY, EVAPORATOR IN	5211A10063A	5211A10063A		R
35211A	TUBE ASSEMBLY, SUCTION SINGLE	5211A10062E	5211A10062E	5211A10062E	R
352380	AIR GUIDE	5238A20004A	5239A10005A	5239A10005A	R
352390	AIR GUIDE ASSEMBLY	5239A30003A	5239A30003A	5239A30003A	R
354210	EVAPORATOR ASSEMBLY, FIRST	5421A10008B	5421A10008B	5421A10008B	R
359012	FAN TURBO	5900A20005A	5900A20005A	5900A20005A	R
550140	ISOLATOR, COMP.	5040AR4195A	5040AR4195A	5040AR4195A	R
552101	TUBE, CAPILLARY	5424AR3411B	5424AR3411B	5210A30018B	R
552111	TUBE ASSEMBLY, CAPILLARY	5211AR3332R	5211AR3332R	5211AR3332R	R
554030	CONDENSER ASSEMBLY, FIRST	5403AR6200C	5403AR6200C	5403AR6200H	R
554160	COMPRESSOR	2520UAEP2FA	2520UAEP2FA	2520UAEP2FA	R
559011	FAN, PROPELLER	5900A20017A	5900A20017A	5900A20017A	R
567502	O.L.P.	6750U-L047A	6750U-L011A	6750U-L011A	R
W0CZZ	CAPACITOR, DRAWING	6120AR2194H	6120AR2194H	6120AR2194H	R
W48602	CLAMP, SPRING	3H02932B	3H02932B	3H02932B	R

NOTE) *Please ensure GCSC since these parts may be changed depending upon the buyer's request.
(GCSC WEBSITE <http://biz@LGservice.com>)

