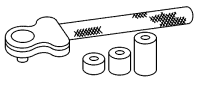
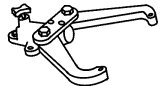
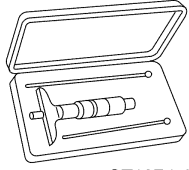
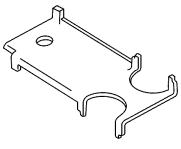
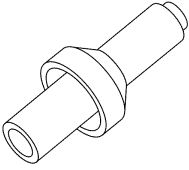
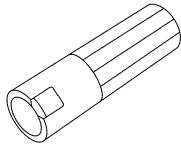

ASSEMBLY

Transmission

Special Tool(s)

 <p>ST1792-A</p>	<p>Adjustment Set, Transmission Band 307-S022 (T71P-77370-A)</p>
 <p>ST1186-A</p>	<p>Holding Fixture, Transmission 307-003 (T57L-500-B)</p>
 <p>ST1274-A</p>	<p>Depth Micrometer 303-D026 (D80P-4201-A) or equivalent</p>
 <p>ST1633-A</p>	<p>Alignment Gauge, TR Sensor 307-351 (T97L-70010-A)</p>
 <p>ST1188-A</p>	<p>Installer, Transmission Extension Housing Oil Seal 307-038 (T74P-77052-A)</p>
 <p>ST1826-A</p>	<p>Sizer, Piston Seal 307-338 (T95L-70010-G)</p>

(Continued)

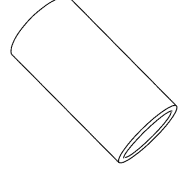
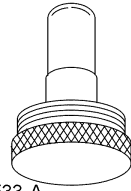
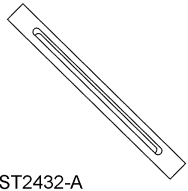
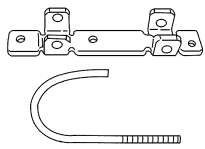
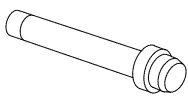
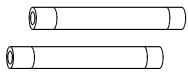

Special Tool(s)

 <p>ST1817-A</p>	<p>Alignment Set, Fluid Pump 307-S039 (T74P-77103-X)</p>
 <p>ST2532-A</p>	<p>Aligner, Fluid Pump Handle 307-431</p>
 <p>ST2533-A</p>	<p>Aligner, Fluid Pump Pilot 307-432</p>
 <p>ST2432-A</p>	<p>Gauge Bar 307-400</p>
 <p>ST2393-A</p>	<p>Compressor, Servo Cover 307-402</p>
 <p>ST1199-A</p>	<p>Installer, Shift Shaft Fluid Seal 307-050 (T74P-77498-A)</p>
 <p>ST1631-A</p>	<p>Handle, Torque Converter 307-091 (T81P-7902-C)</p>

(Continued)

ASSEMBLY (Continued)

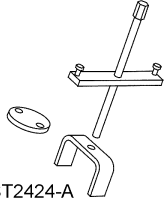
Special Tool(s)

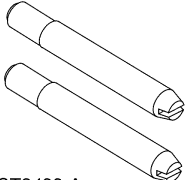
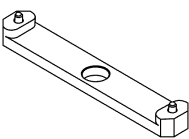
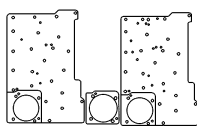
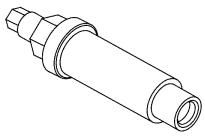
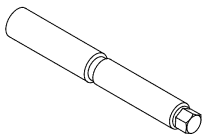
 <p>ST2424-A</p>	<p>Compressor, Cushion Spring 307-401</p>
 <p>ST1639-A</p>	<p>Aligner, Valve Body 307-334 (T95L-70010-C)</p>
 <p>ST2433-A</p>	<p>Alignment Pins, Transmission Pump 307-399</p>
 <p>ST2426-A</p>	<p>Aligner, Flex Plate 307-403</p>
 <p>ST2538-A</p>	<p>Air Test Plate 307-433-01, 307-433-2, 307-433-3</p>
 <p>ST2440-A</p>	<p>Installer, Drive Pinion flange 205-479</p>
 <p>ST2416-A</p>	<p>Installer, Output Shaft Flange 307-404</p>

Material

Item	Specification
MERCON® V Automatic Transmission Fluid XT-5-QM	MERCON® V
Multi-Purpose Grease XG-4	ESR-M1C159-A

1. Thoroughly clean the transmission case and extension housing in solvent and blow dry with compressed air.
2. Inspect the transmission case for the following:
 - Stripped bolt hole threads
 - Gasket and mating surfaces for burrs or nicks
 - Obstructions to vent and fluid passages
 - Cracks or warpage

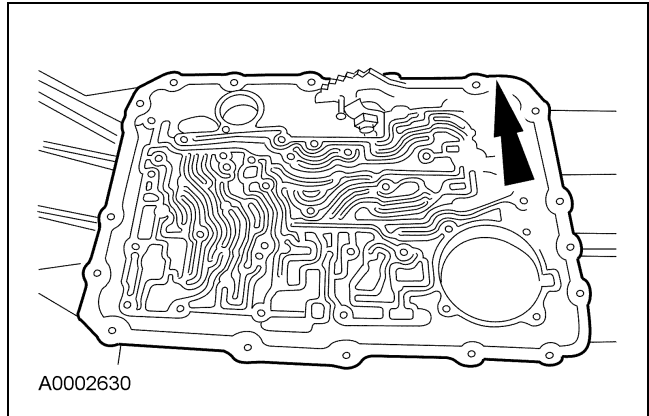

3. Inspect the extension housing for cracks, burrs or warpage.

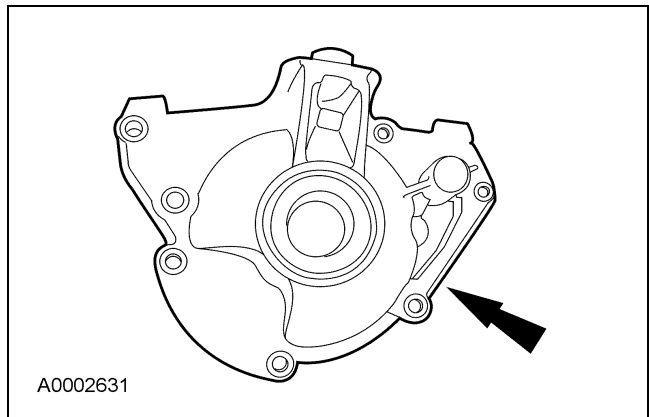

ASSEMBLY (Continued)

4. Inspect the case bearing for damage. If damage to the case bearing is indicated, install a new case.

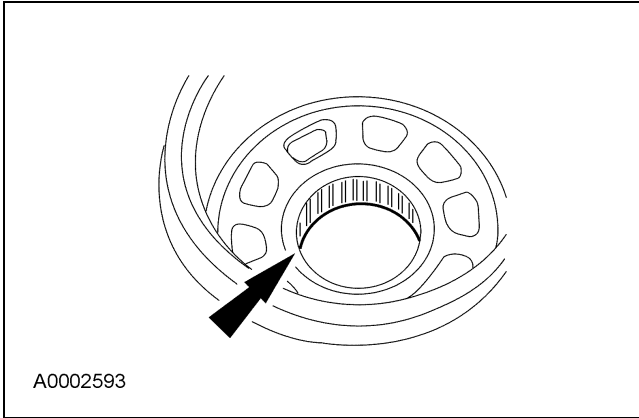

5. **⚠ WARNING:** Make sure the lock pin on bench-mounted holding fixture is secure. Failure to follow these instructions may result in personal injury.

Using the special tool, install the transmission into the bench with the converter housing facing up.

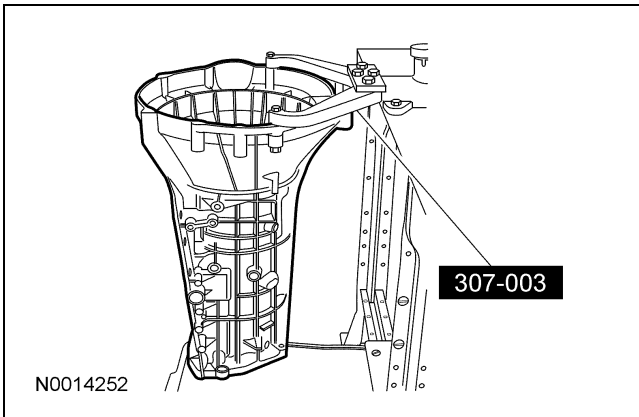

6. Using the special tool, install the manual control lever shaft seal and lubricate it with petroleum jelly.

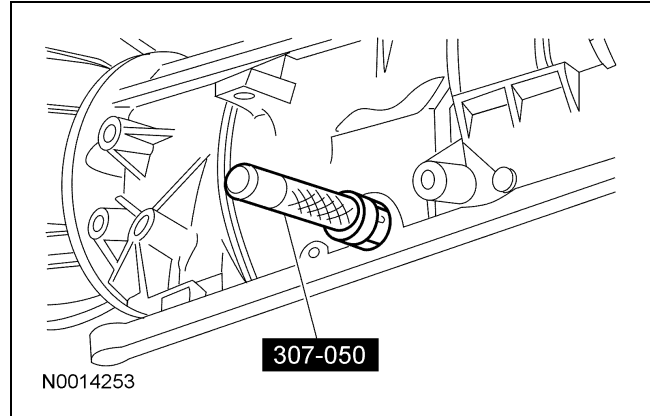

7. Install the parking lever rod.

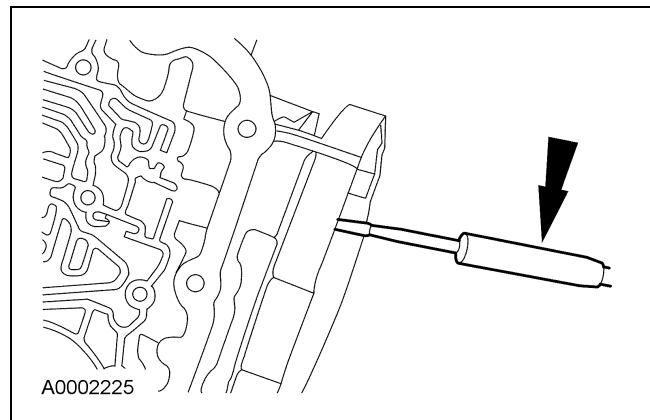

8. Install the manual control lever.

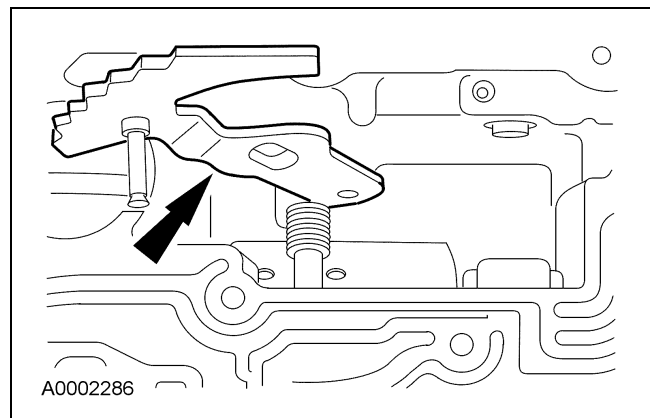

ASSEMBLY (Continued)

9. Assemble the manual valve inner lever and parking lever actuating rod as shown.

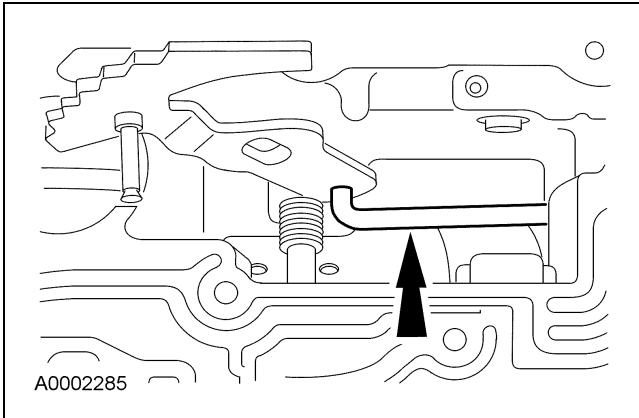

10. **CAUTION:** Align the flats on the manual valve inner lever with the flats on the manual control lever shaft.

Install the manual control lever shaft.

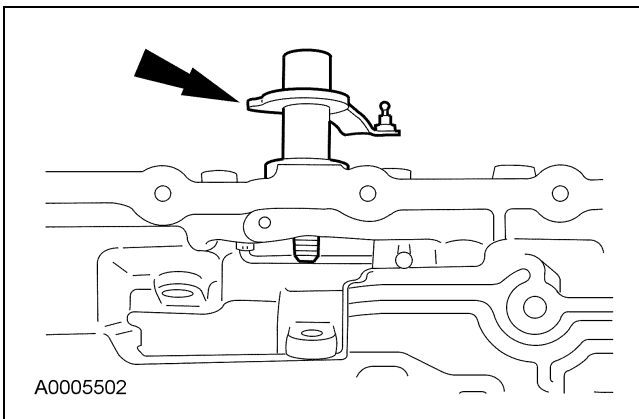

11. Install the manual valve inner lever onto the manual shaft and loosely install the nut.

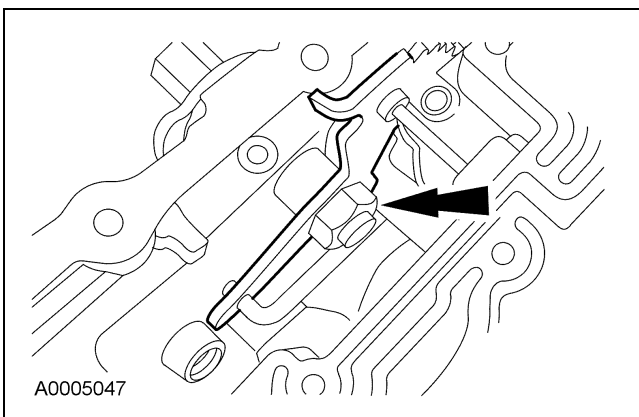

12. **CAUTION:** Use care not to damage the fluid pan rail surface when installing the retaining pin.

NOTE: Align the manual control lever shaft alignment groove with the manual control lever shaft spring pin bore in the transmission case.

Install the manual control lever shaft spring pin.

- Tap the manual control lever shaft spring pin into the transmission case.

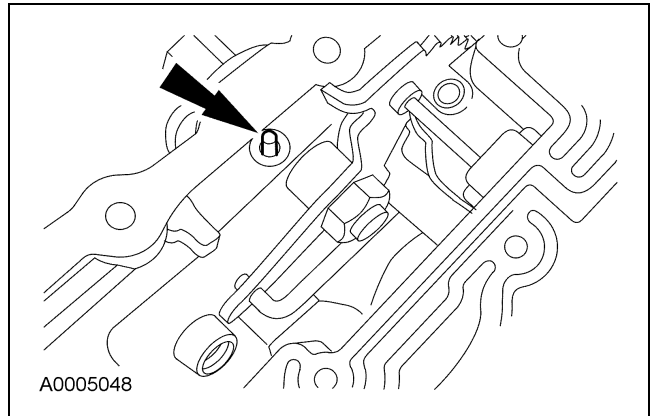

13. **CAUTION:** To avoid damage, do not allow the wrench to strike the manual valve inner lever pin.

Tighten the nut.

- Tighten to 48 Nm (35 lb-ft).

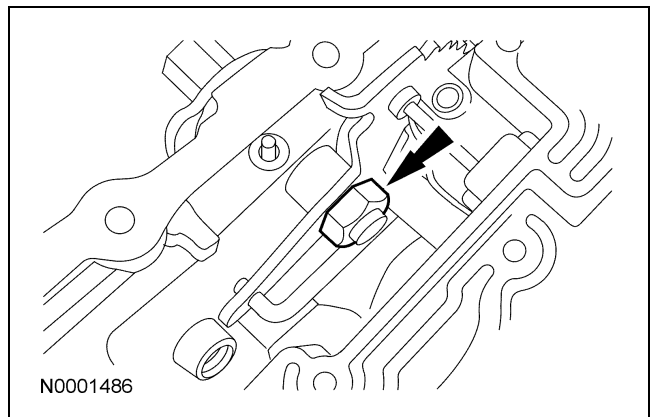

ASSEMBLY (Continued)

14.  **CAUTION:** The tabs on the output shaft thrust washer (No. 11) point into the case. Make sure the thrust washer is correctly seated.

Install the output shaft thrust washer (No. 11).

- Coat the output shaft thrust washer with petroleum jelly.

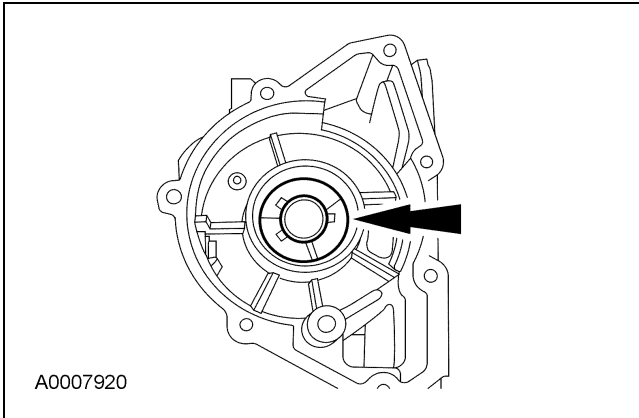

15. Install the park gear on the output shaft.

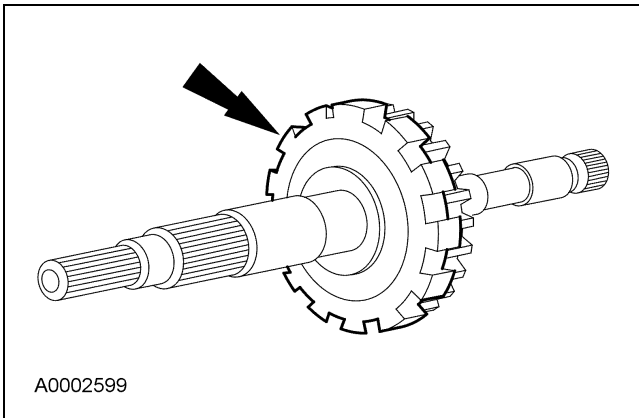

16. Install the output shaft and park gear.

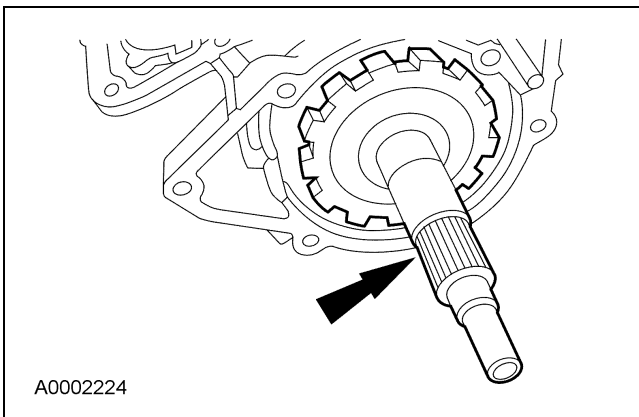

17. Install the low/reverse brake drum.
- Rotate the low/reverse brake drum clockwise to install.

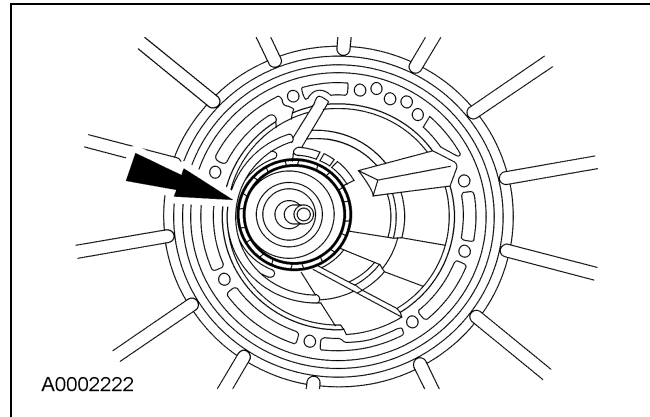

18.  **CAUTION:** Make sure band is resting on the 2 anchor pins in the case.

Install the low/reverse band over the reverse drum.

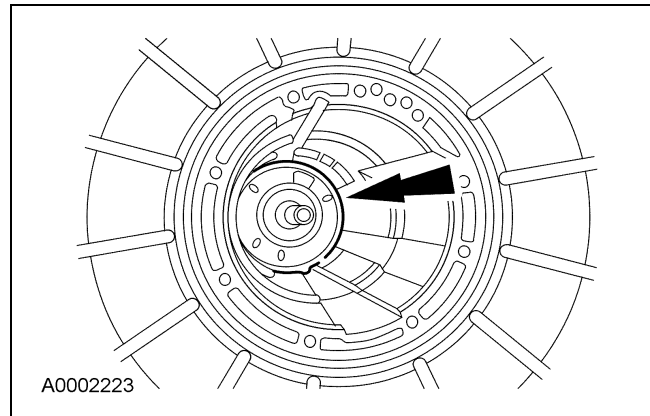

19. **NOTE:** The reverse band actuating lever must fit into the notches in the band.

Install the reverse band actuating lever into the reverse band.

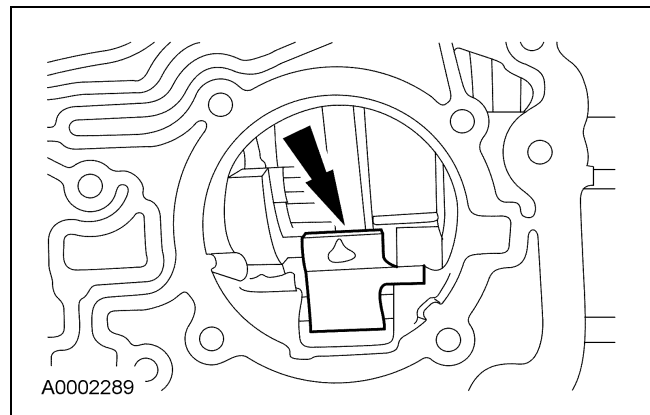

ASSEMBLY (Continued)

20. Install the reverse band actuating lever shaft into the case and into the reverse band actuating lever.

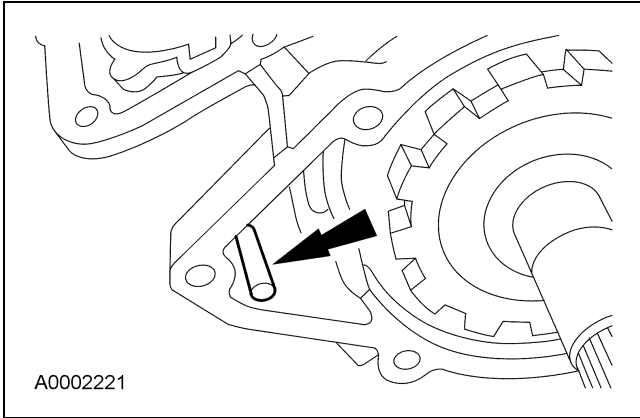

21. Install the No. 10 needle bearing into the case.

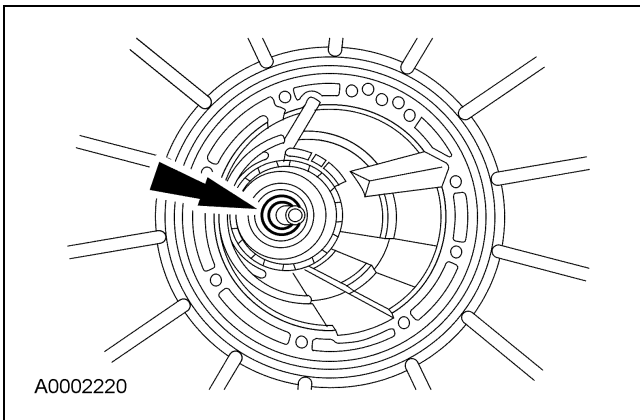

22. **⚠ CAUTION: Do not damage the seal against the case during assembly.**

Install the output shaft ring gear, hub and seal.

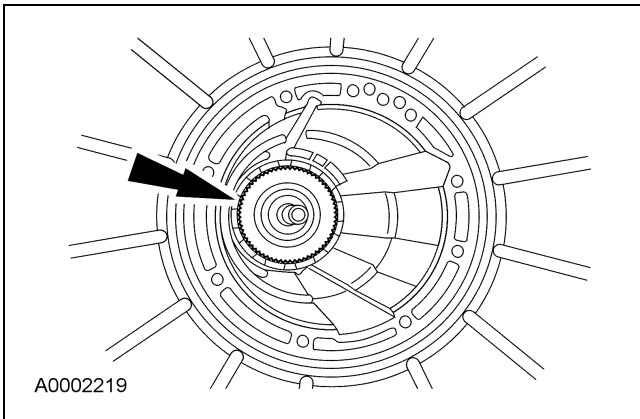

23. **⚠ CAUTION: Always install a new output shaft retaining ring.**

Install a new output shaft retaining ring.

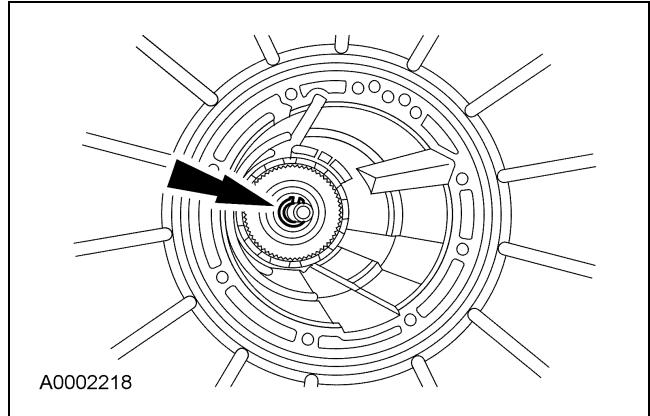

24. **NOTE:** Install the output shaft sleeve with the cone facing up. This sleeve will snap into place when correctly installed.

Install the output shaft sleeve.

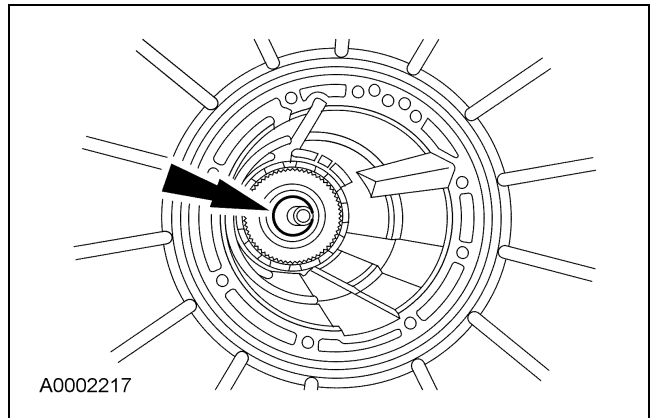

25. Install low/reverse planetary carrier needle bearing (No. 9) onto the output shaft ring gear and hub assembly.

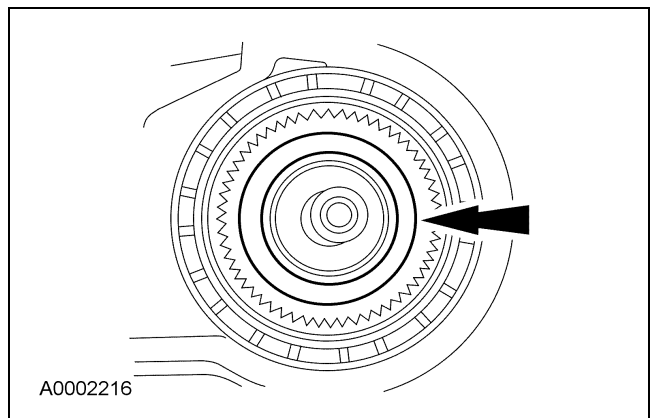

ASSEMBLY (Continued)

- 26. **⚠ CAUTION: Make sure the needle bearings stay in place.**

Install the low/reverse planetary assembly.

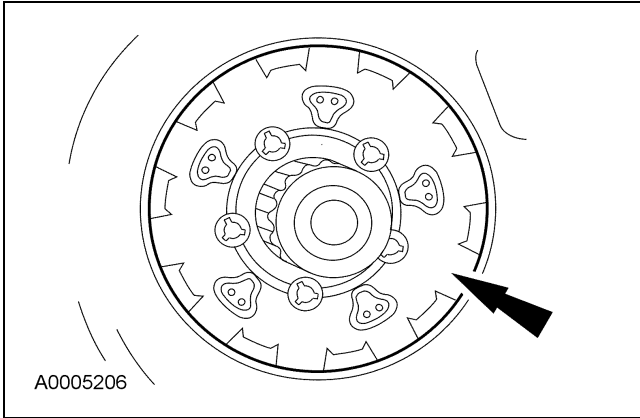

- 27. **⚠ CAUTION: The low/reverse brake drum must be pulled forward to install the low/reverse planet retaining ring.**

Install the retaining ring.

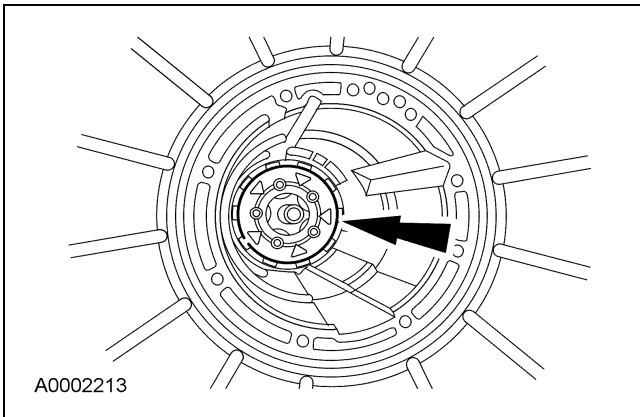

- 28. Install the No. 8 thrust bearing.

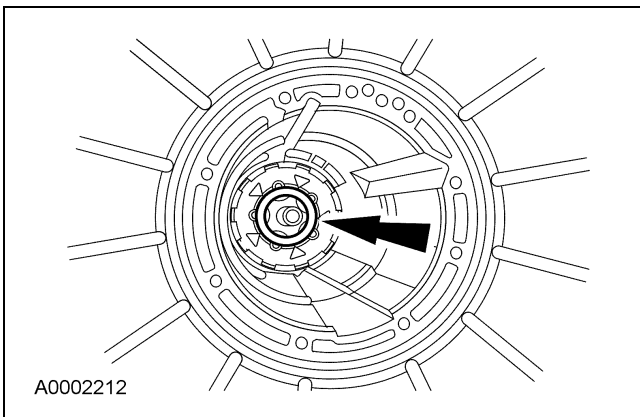

- 29. Install the spacer on the input shell, using petroleum jelly to hold it in place.

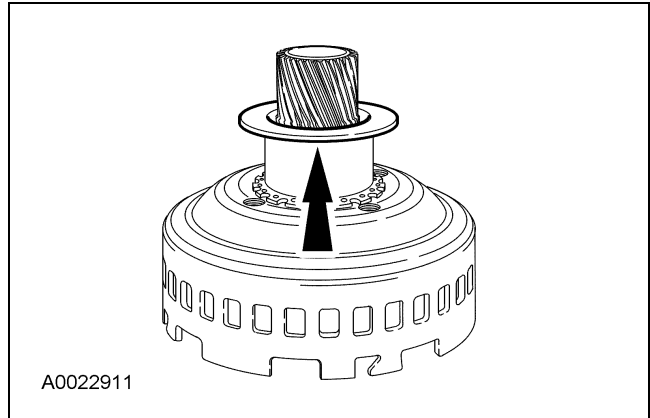

- 30. Install the input shell and sun gear assembly.

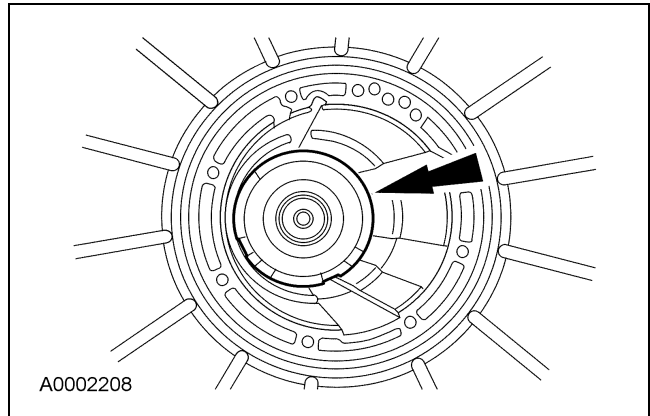

- 31. **NOTE: The No. 13 bearing must be properly seated in the forward planet assembly so the sun gear can be installed correctly.**

Install the forward planetary assembly.

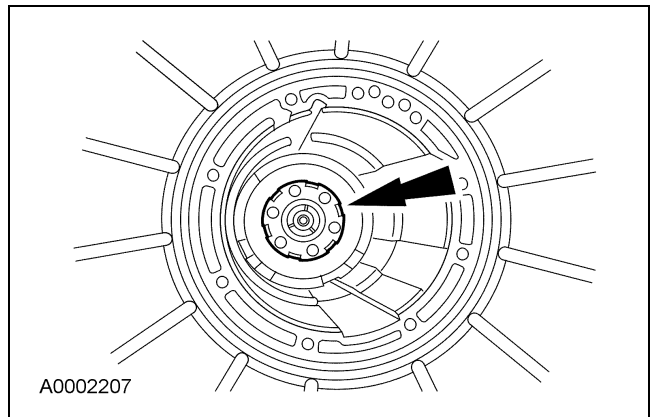

ASSEMBLY (Continued)

32. Install the No. 7 forward planet thrust bearing into the forward ring gear and hub assembly. Use petroleum jelly to hold the bearing in place.

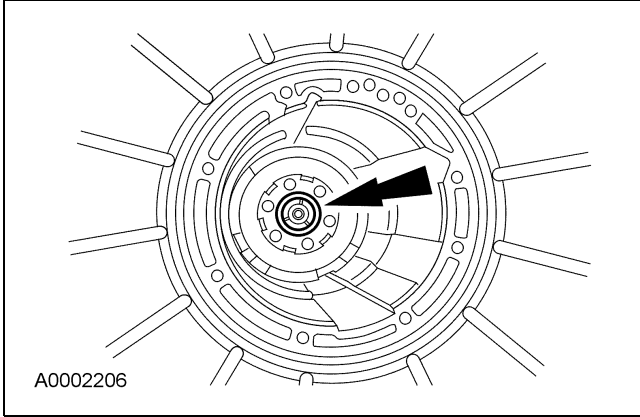

35. Install the No. 6A forward ring gear hub thrust bearing into the forward ring gear and hub.

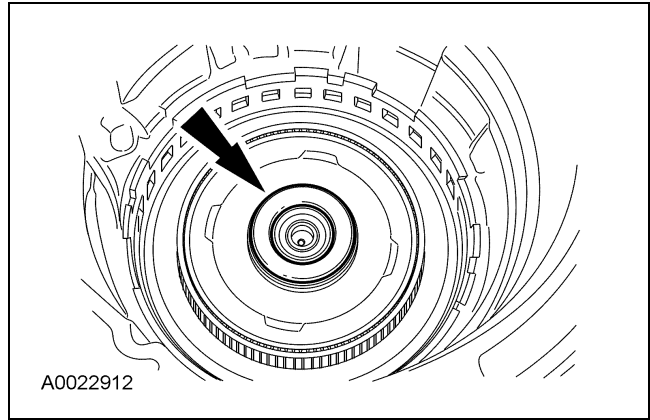

33. Install the No. 6B forward clutch thrust washer onto the forward ring gear hub.

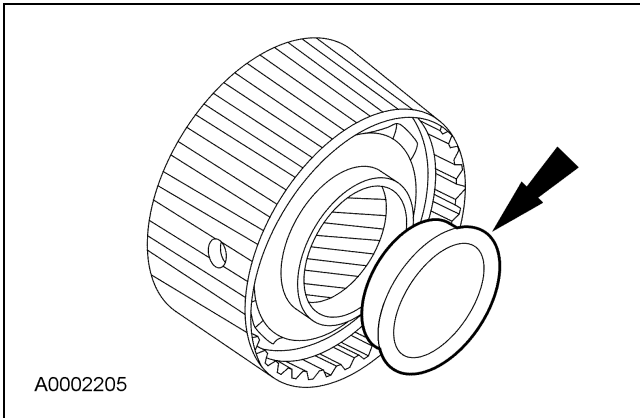

36. Install the forward clutch cylinder.

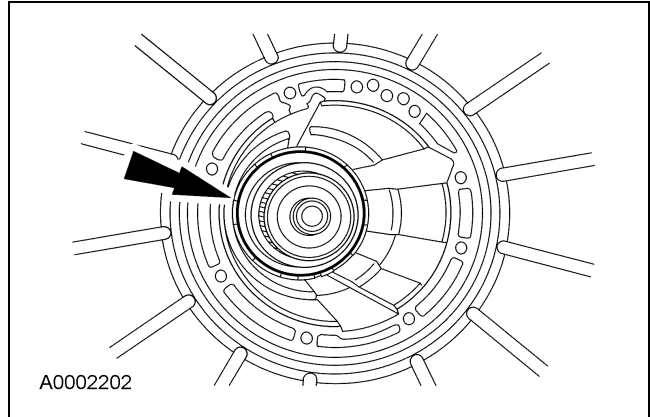

34. Install the forward ring gear and hub as an assembly.

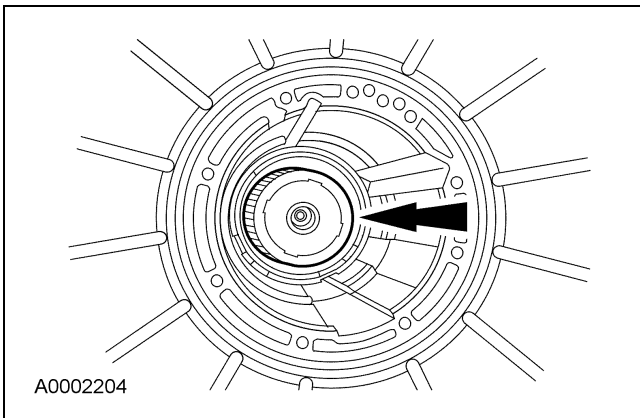

37. Install the No. 5 thrust bearing.

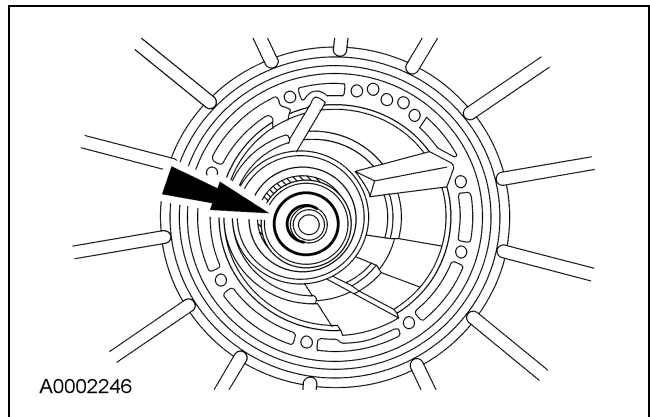

ASSEMBLY (Continued)

38. Install the intermediate servo piston and spring.

- Lubricate the servo bore with clean automatic transmission fluid.

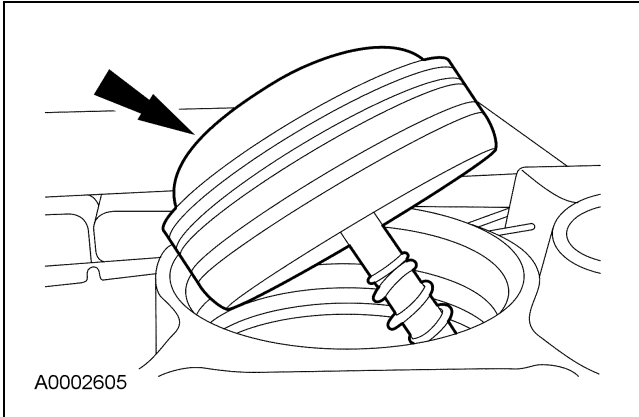

39. Using the special tool, install the retaining ring.

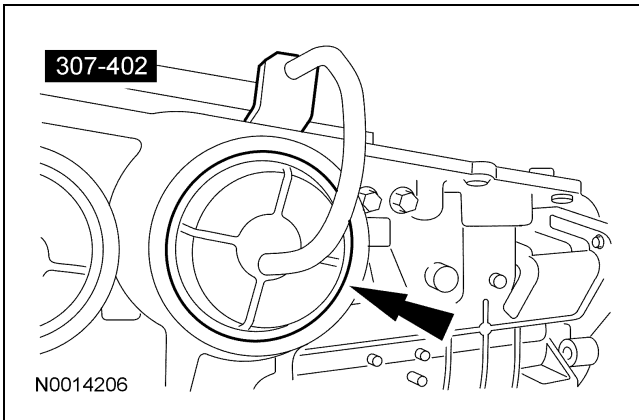

40. Install the direct clutch drum.

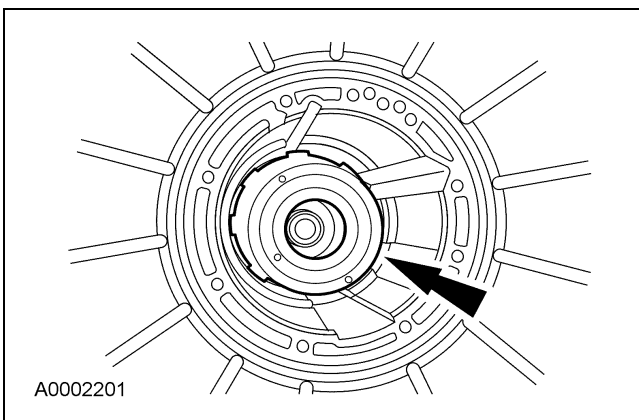

41. Using a depth micrometer with an 8-inch extension, measure from the top of the gauge bar to center support ledge in case at 4 places 90 degrees apart.

- Add the 4 measurements, divide by 4, and record as dimension A.

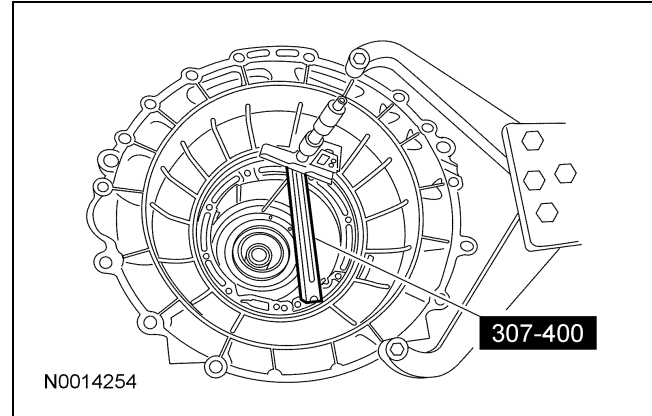

42. **⚠ CAUTION: The torque specifications are critical for this procedure. Failure to use the correct torque specifications may cause transmission damage.**

Install the special tool.

- 1 Install the special tool and the bolts using the 2 pump screw locations at approximately 6 and 12 o'clock positions.
 - Tighten to 15 Nm (11 lb-ft).
- 2 Tighten the center screw.
 - Tighten to 1 Nm (10 lb-in).

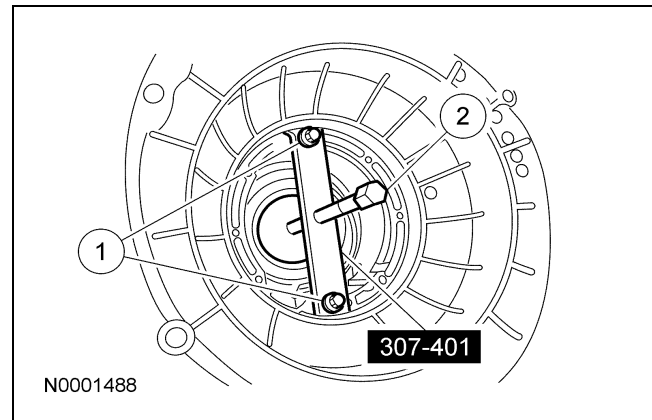

ASSEMBLY (Continued)

43. **NOTE:** Align the disc holes on special tool with the slot in gauge bar for correct measurement.

Measure the distance from the top of the gauge bar to the drum bearing surface through the hole in the disc and record as dimension B. Repeat measurement 180 degrees opposite side of the special tool and record as dimension C.

44. Add dimension B to C, divide by 2 and record as dimension D.

45. Subtract A from D, and record as dimension E.

46. Select bearing from the following chart, using dimension E.

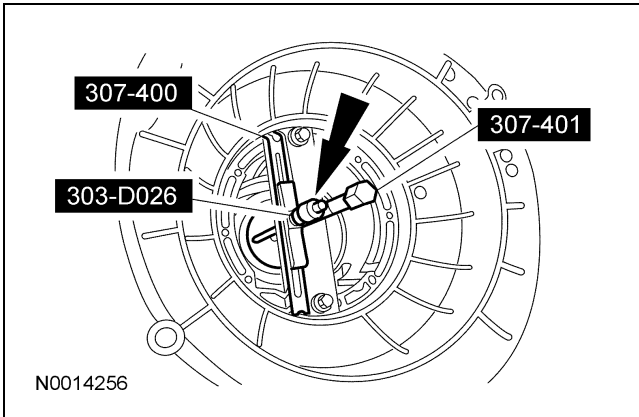

Dimension E	Service Part Number (7D014)	Bearing Thickness	Identification (Notches)
1.69-1.87 mm (0.066-0.074 in)	XW4Z-CA	2.65-2.80 mm (0.104-0.110 in)	None
1.88-2.04 mm (0.073-0.080 in)	XW4X-DA	2.83-2.98 mm (0.111-0.116 in)	One
2.05-2.22 mm (0.081- 0.088 in)	XW4Z-EA	3.01-3.16 mm (0.118-0.124 in)	Two
2.23-2.43 mm (0.088-0.096 in)	XW4Z-FA	3.21-3.36 mm (0.126-0.132 in)	Three

47. **NOTE:** Make sure that the intermediate band apply strut is aligned with the band notch.

NOTE: If the intermediate band is reused, it must be installed in the same position as when removed.

NOTE: The new intermediate band is dark in color. This is a normal condition of the band. Hairline cracks in the band are also considered normal. Do not install a new band based solely on the color.

Install the intermediate band.

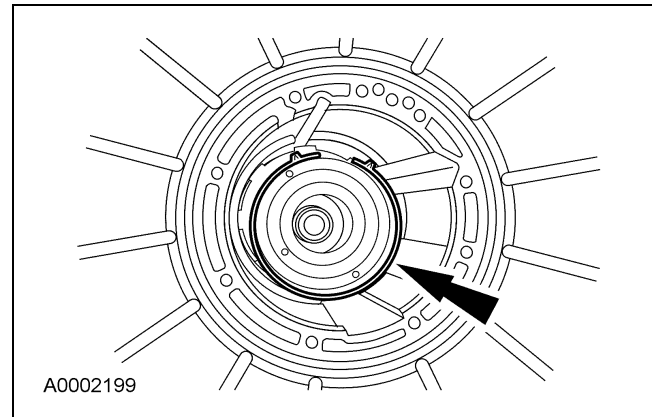

ASSEMBLY (Continued)

48. Install the intermediate band anchor strut.

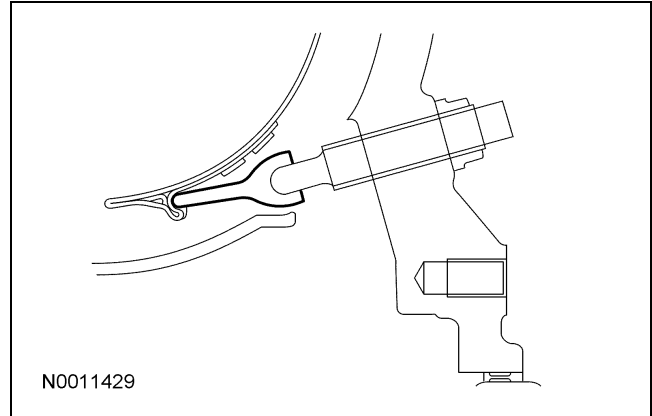
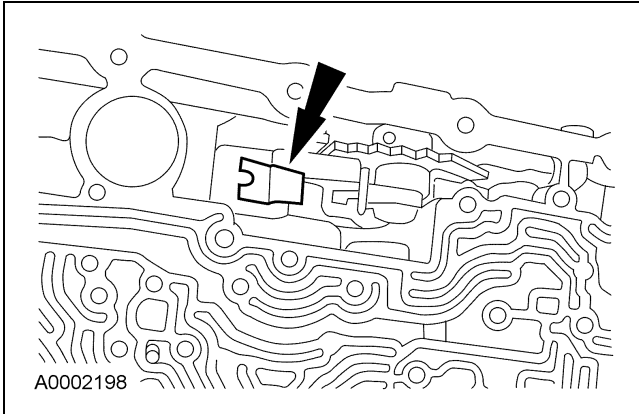

49. **⚠ CAUTION:** To avoid a “fall-out” condition of the strut from the screw during assembly and function, the small “U” shape notch should be toward the band/case side and the large “U” shape notch toward the main control side.

Position the strut in the transmission case.

- 1 Band/case side of the anchor (small U notch).
- 2 Main control side of the anchor (large U notch).

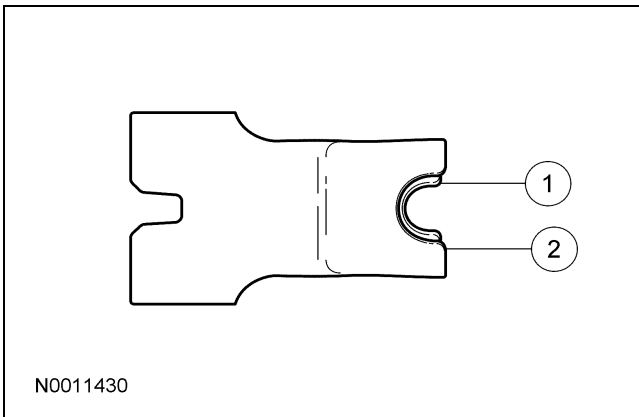

50. **⚠ CAUTION:** If the strut is installed incorrectly, transmission damage will occur.

Check to make sure that the intermediate band anchor strut is installed in the correct orientation to the case and adjustment screw.

51. Loosely install the screw.

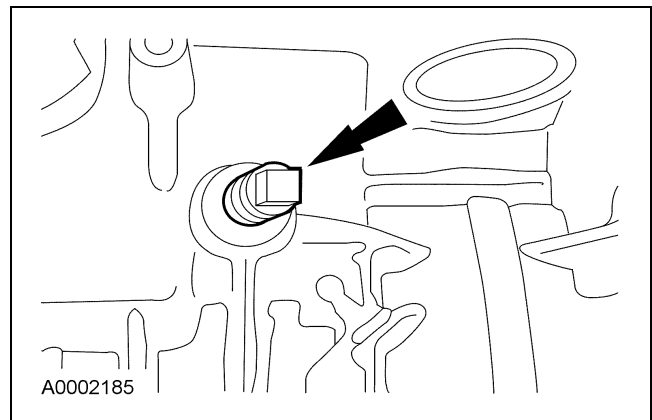

52. Install the intermediate band apply strut.

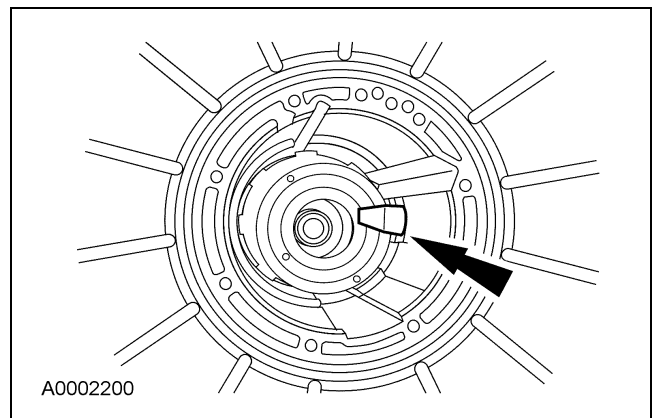

ASSEMBLY (Continued)

53.  **CAUTION: If the strut is installed incorrectly, transmission damage will occur.**

Check to make sure that the intermediate band apply strut is installed in the correct orientation to the case and piston rod.

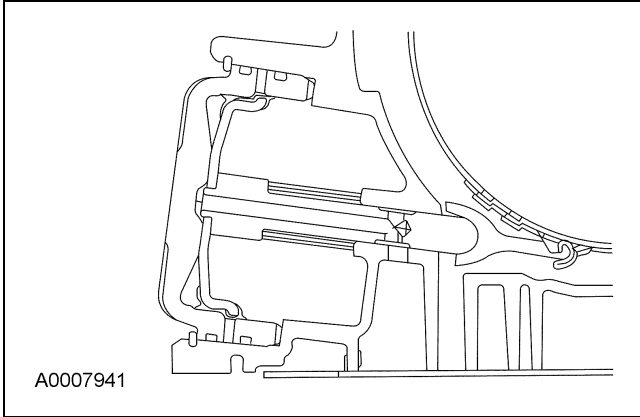

54. Install the selected No. 4 thrust washer on the direct clutch drum.
- Coat the thrust washer with petroleum jelly.

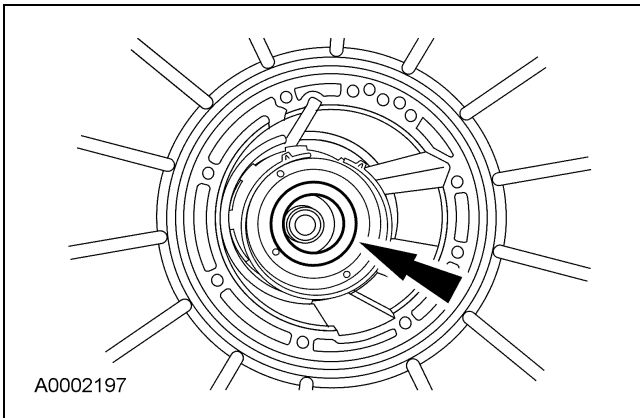

55. **NOTE:** Align the center support screw hole with correct case hole.
- Install the center support.

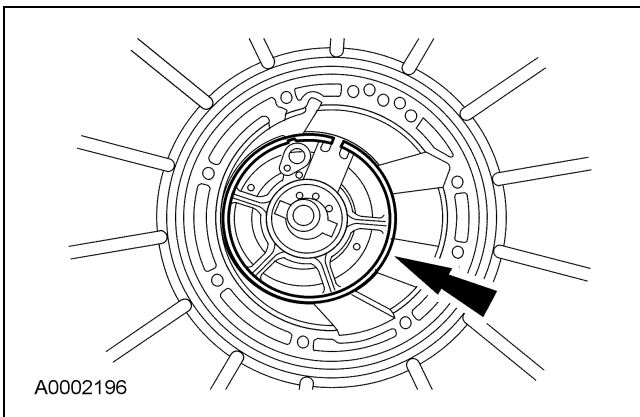

56. Install the center support locknut and cage.

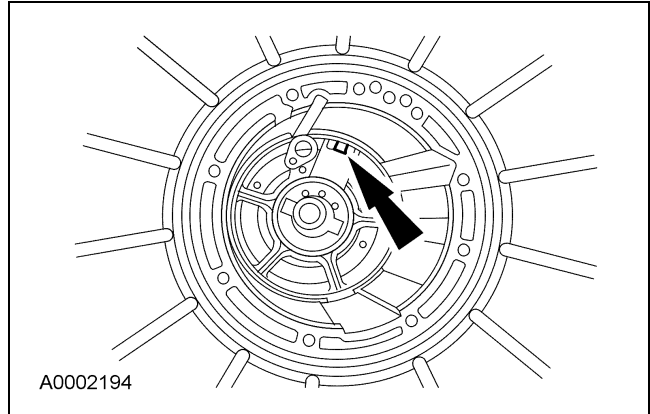

57. Loosely install the screw.

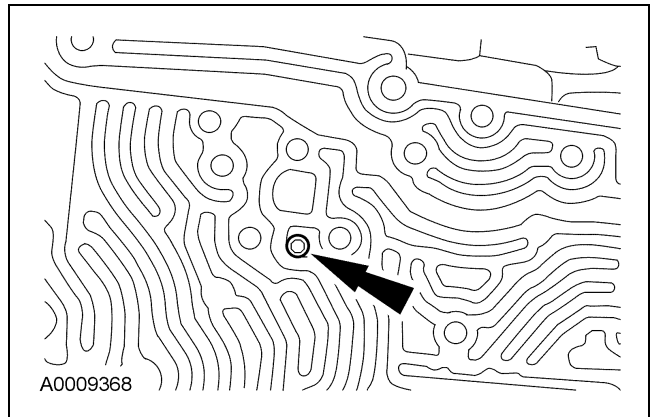

ASSEMBLY (Continued)

58.  **CAUTION:** Install the center support retaining ring with the tapered side facing up.

 **CAUTION:** Make sure the notch opening is not obstructed by the center support retaining ring.

Install the center support retaining ring.

- 1 Make sure the center support retaining ring is installed with the tapered side facing up.
- 2 Make sure the opening of the center support retaining ring is positioned correctly.

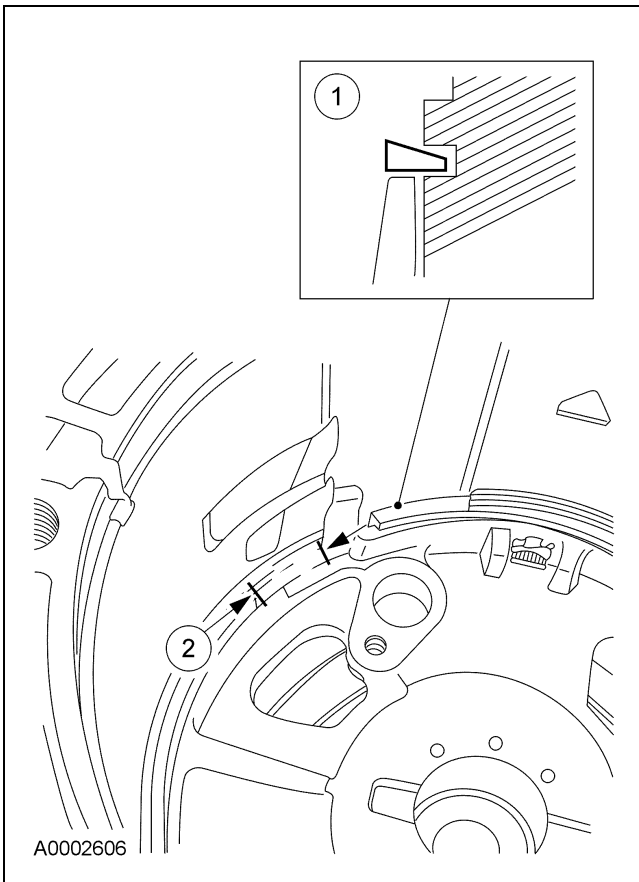

59. Install the center shaft thrust bearing (No. 3).

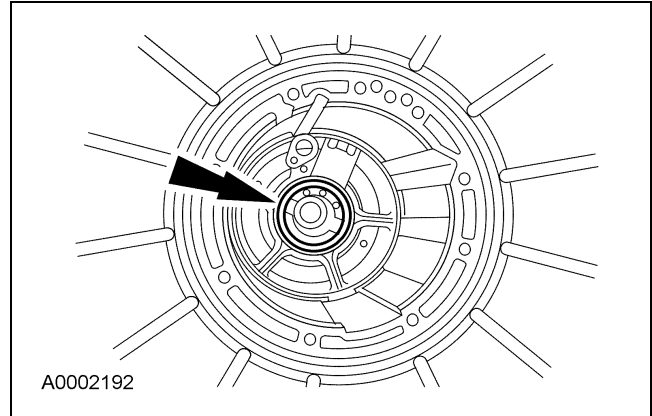

60. Install the overdrive ring gear, overdrive one-way clutch and center shaft assembly.

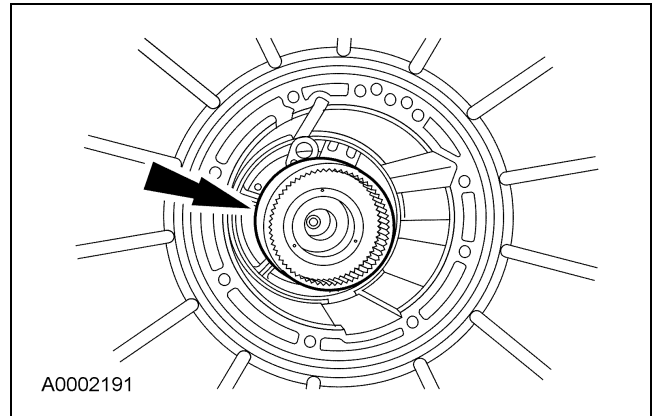

61.  **CAUTION:** Do not bend the trigger wheel. Make sure that the No. 2 thrust bearing is in this assembly.

Install the planetary gear overdrive carrier.

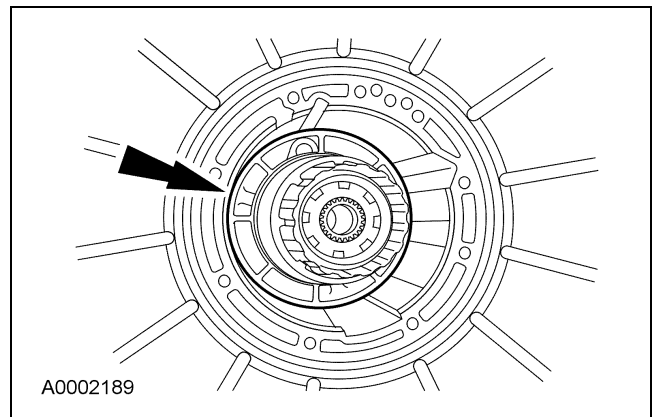

ASSEMBLY (Continued)

62. Install the overdrive brake drum and coast clutch drum assembly.

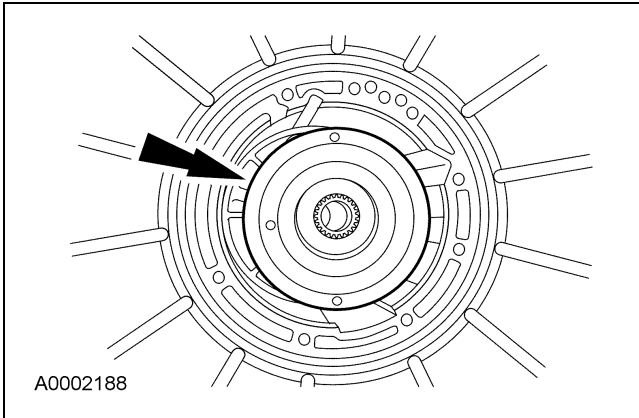

63. Install the overdrive band servo piston and spring.

- Lubricate the servo bore with clean automatic transmission fluid.

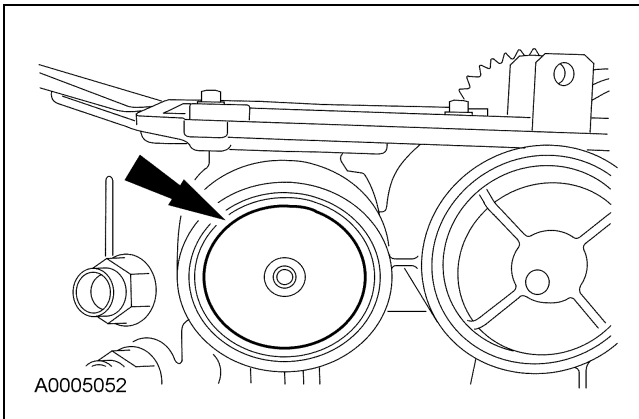

64. Using the special tools, install the retaining ring.

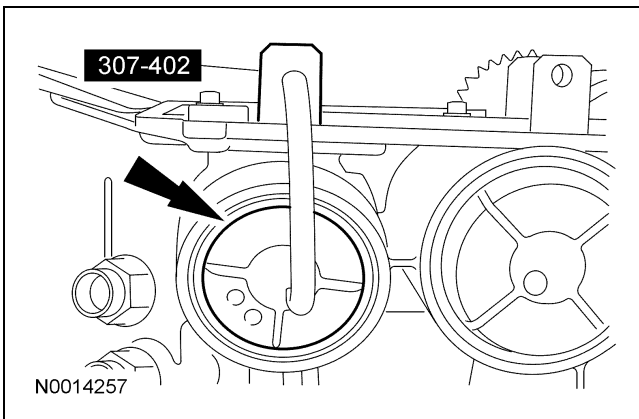

65. **NOTE:** If the overdrive band is reused, it must be installed in the same position as when removed.

NOTE: Make sure that the overdrive band apply strut is aligned with the band notch.

NOTE: The new overdrive band is dark in color. This is a normal condition of the band. Hairline cracks in the band are also considered normal. Do not install a new band based solely on the color.

Install the overdrive band.

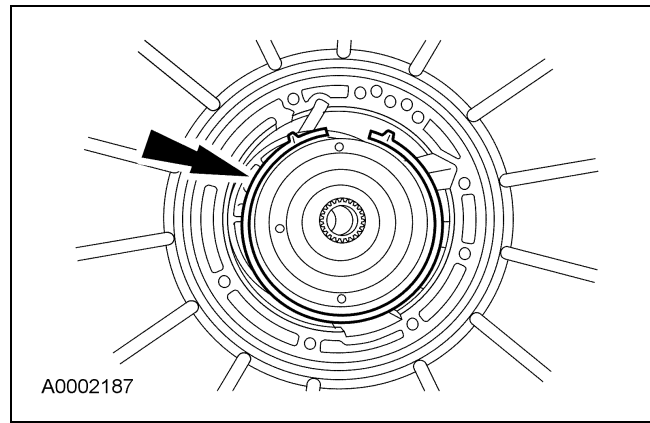

66. Install the overdrive anchor strut.

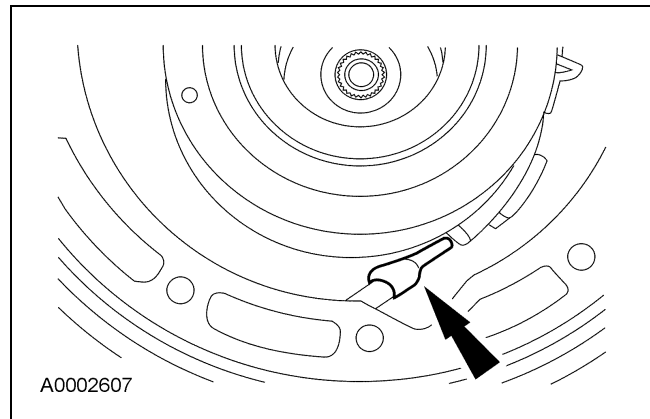



ASSEMBLY (Continued)

67.  **CAUTION:** To avoid a “fall-out” condition of the strut from the screw during assembly and function, the small “U” shape notch should be toward the band/case side and the large “U” shape notch toward the main control side.

Position the strut in the transmission case.

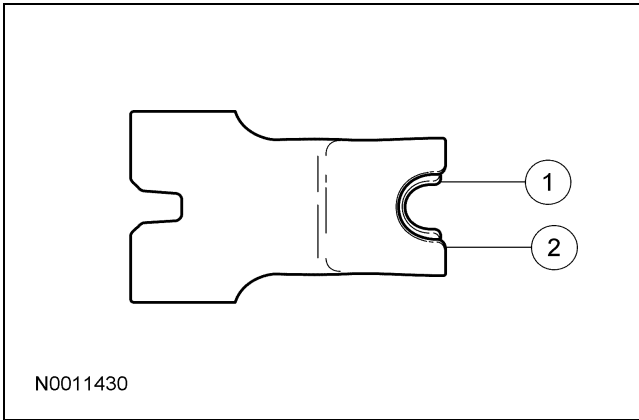
- 1 Band/case side of the anchor (small U notch).
- 2 Main control side of the anchor (large U notch).



68.  **CAUTION:** If the strut is installed incorrectly, transmission damage will occur.

Check to make sure that the intermediate band anchor strut is installed in the correct orientation to the case and adjustment screw.

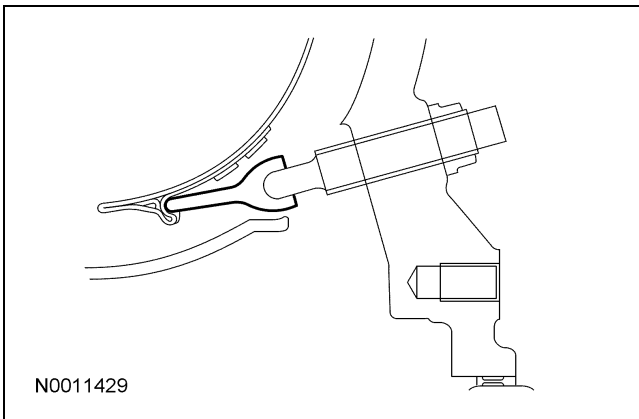

69.  **CAUTION:** If the strut is installed incorrectly, transmission damage will occur.

Check to make sure that the overdrive band anchor strut is installed in the correct orientation to the case and adjustment screw.

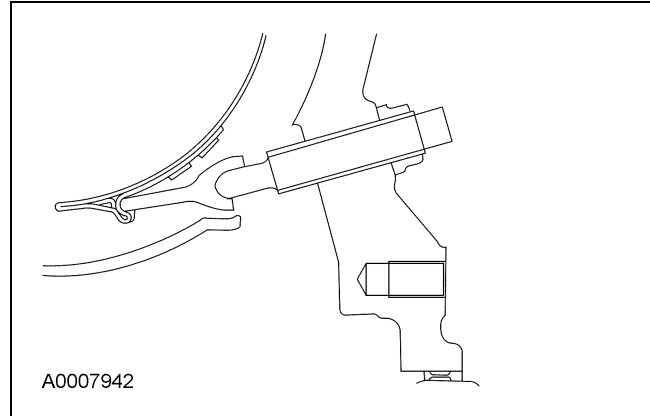

70. Loosely install the screw.

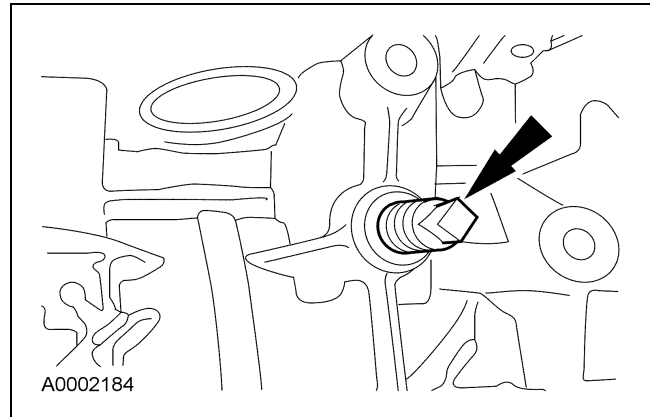

71. Install the overdrive apply strut.

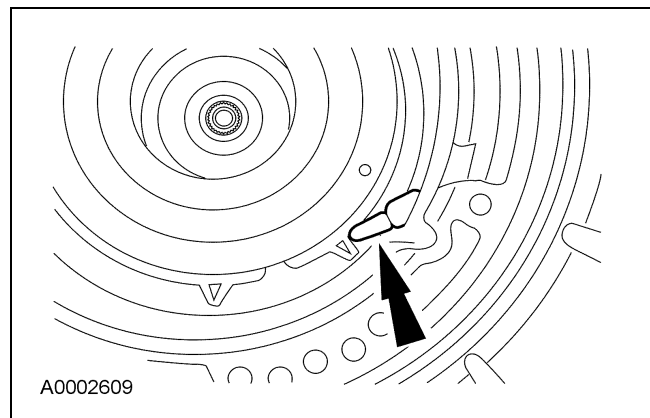

ASSEMBLY (Continued)

72. **⚠ CAUTION: If the strut is installed incorrectly, transmission damage will occur.**

Check to make sure that the overdrive band apply strut is installed in the correct orientation to the case and piston rod.

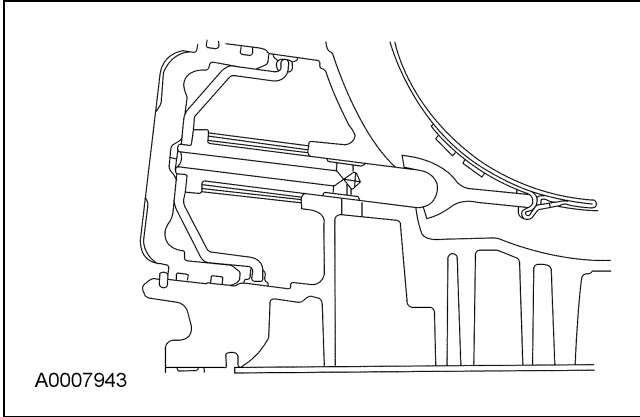

73. **⚠ CAUTION: The torque specifications are critical for this procedure. Failure to use the correct torque specifications may cause transmission damage.**

Install the special tool.

- 1 Install the special tool and the bolts using the 2 pump screw locations at approximately 6 and 12 o'clock positions.
 - Tighten to 15 Nm (11 lb-ft).
- 2 Tighten the center screw.
 - Tighten to 1 Nm (10 lb-in).

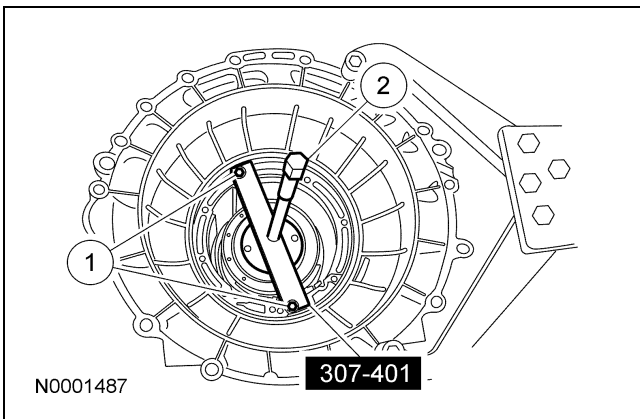

74. **NOTE: Align the disc holes on special tool with the slot in gauge bar for correct measurement.**

Measure the distance from the top of the gauge bar to the drum bearing surface through the hole in the disc and record as dimension A. Repeat measurement 180 degrees opposite side of the special tool and record as dimension B.

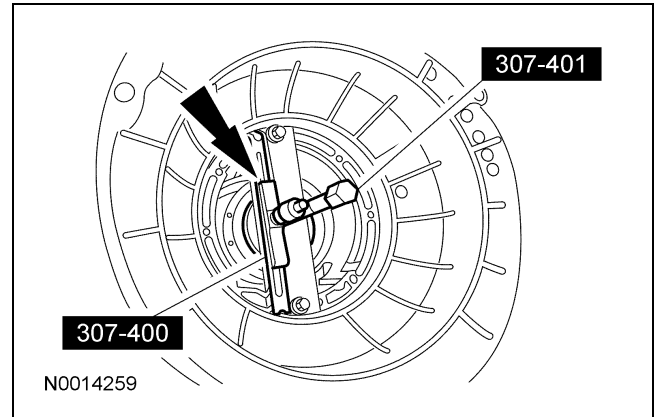

75. Add dimension A to B, divide by 2 and record as dimension C.

76. Subtract the thickness of the gauge bar 17.78 mm (0.70 in) from dimension C, and record as dimension D.

77. Select the No. 1 thrust bearing from the following chart using dimension D.

Dimension D	Service Part Number (7D014)	Bearing Thickness	Identification (Color/ID)
38.05-38.13 mm (1.50 in)	F7TZ-TA	1.55-1.60 mm (0.061-0.063 in)	White
38.14-38.28 mm (1.50-1.51 in)	F7TZ-MA	1.75-1.80 mm (0.069-0.071 in)	Green

ASSEMBLY (Continued)

Dimension D	Service Part Number (7D014)	Bearing Thickness	Identification (Color/ID)
38.29-38.42 mm (1.51 in)	F7TZ-NA	1.85-1.90 mm (0.073-0.075 in)	Red
38.43-38.61 mm (1.51-1.52 in)	F7TZ-RA	2.05-2.10 mm (0.081-0.083 in)	Black
38.62-38.74 mm (1.52-1.53 in)	F7TZ-SA	2.15-2.20 mm (0.095-0.097 in)	Yellow

78. Install the selected No. 1 fluid pump input thrust washer.

- Coat the fluid pump input thrust washer with petroleum jelly.

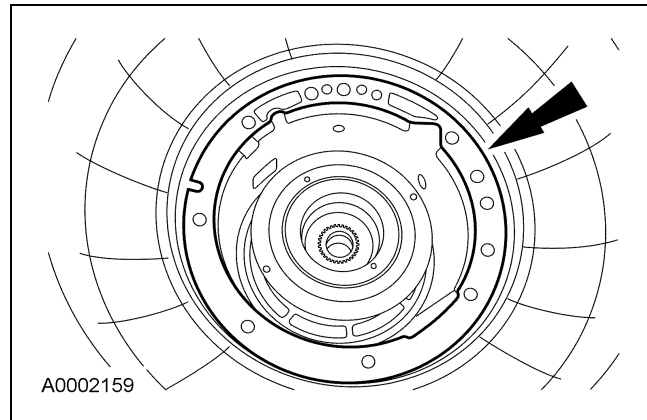
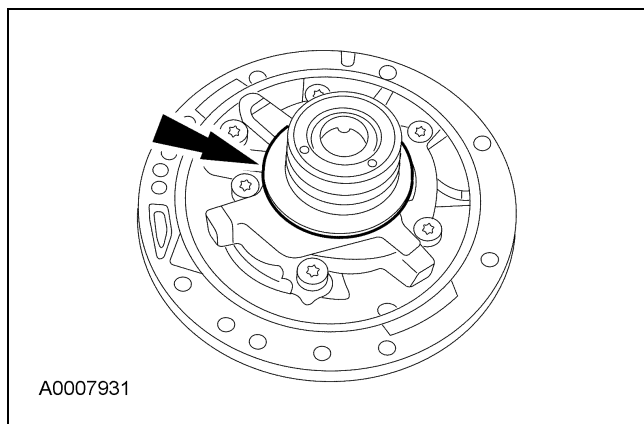

81. **⚠ CAUTION:** Make sure that the fluid pump inlet thrust washer (No. 1), selective thrust washer, fluid pump gasket and the fluid pump-to-case O-ring seal remain in the correct position throughout this step.

Install the fluid pump.

79. Install the special tools into the transmission case.

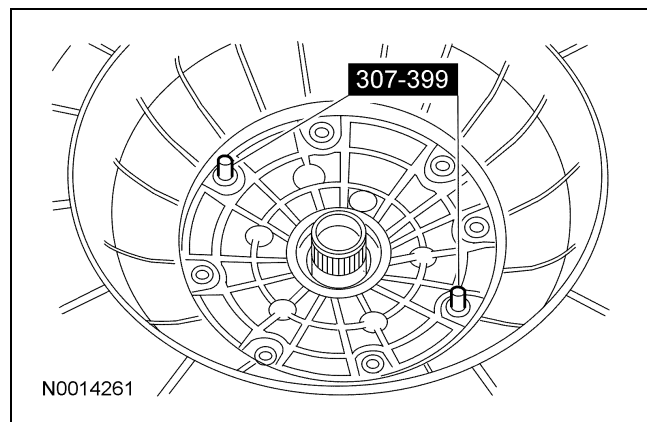
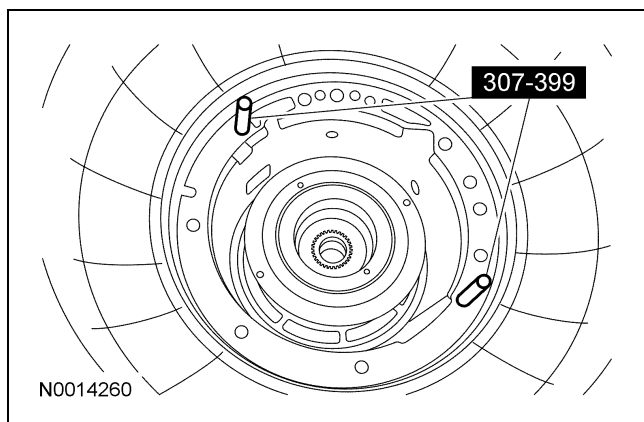

80. Install the pump gasket.

ASSEMBLY (Continued)

82. ⚠ **CAUTION:** The special tools must be used to correctly align the pump with the adapter plate to reduce gear noise, bushing failure and leakage.

Using the special tool, align the fluid pump to the adapter plate.

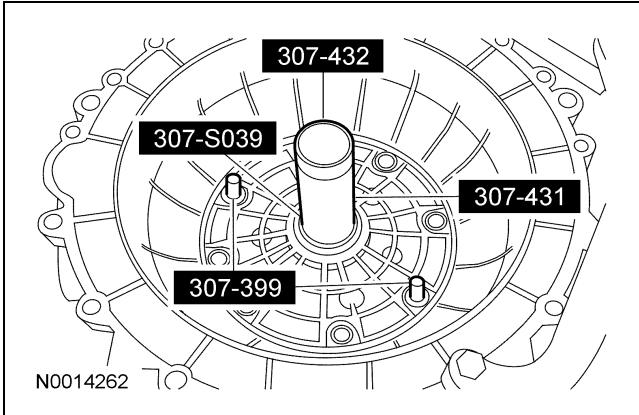

83. Install screws. Tighten the screws in a star pattern.

- Tighten to 25 Nm (18 lb-ft).

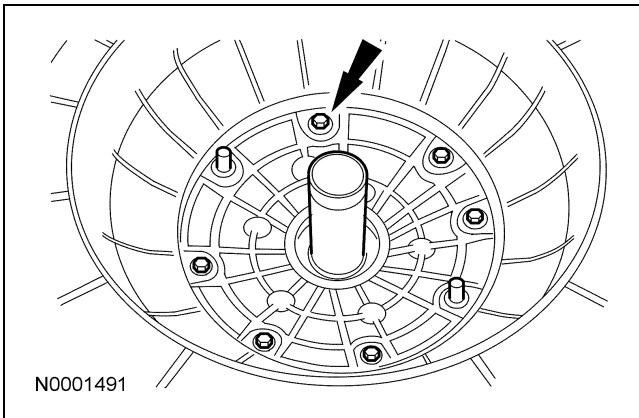

84. Remove the special tools and install the 2 remaining screws.

- Tighten to 25 Nm (18 lb-ft).

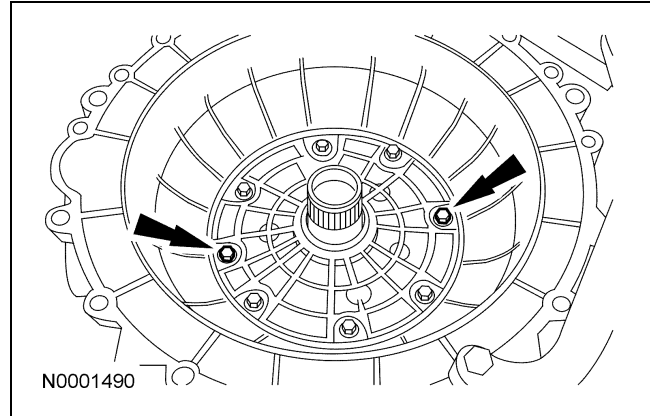

85. ⚠ **CAUTION:** Do not allow overdrive band adjustment screw to back out. Band strut could fall out of position.

⚠ **CAUTION:** Install, but do not tighten, a new locknut on the band adjustment screw. Apply petroleum jelly to the locknut seal.

Install a new locknut on the band adjustment screw.

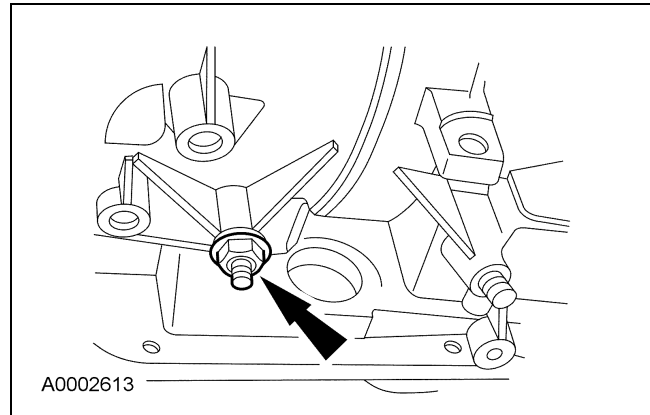

ASSEMBLY (Continued)

86. **⚠ CAUTION: The overdrive servo must be installed prior to band adjustment.**

Using the special tool, tighten the overdrive band adjustment screw. Then back off the screw exactly 1.5 turns and hold that position.

- Tighten to 14 Nm (10 lb-ft).

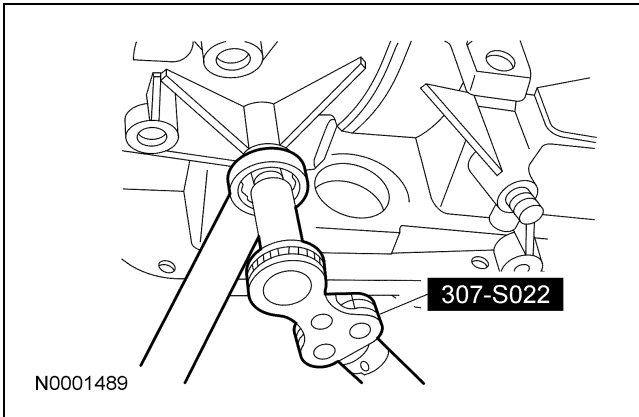

87. Tighten the overdrive band locknut.

- 1 Hold the overdrive band adjustment screw stationary.
- 2 Tighten the overdrive band locknut.
 - Tighten to 54 Nm (40 lb-ft).

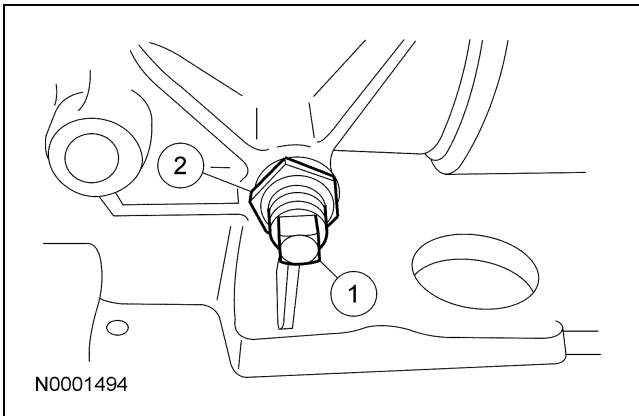

88. **⚠ CAUTION: Do not allow the intermediate band adjusting screw to back out. Band strut could fall out of position.**
- ⚠ CAUTION: Install, but do not tighten, a new locknut on the band adjustment screw. Apply petroleum jelly to the locknut seal.**
- Install new nut on the band adjustment screw.

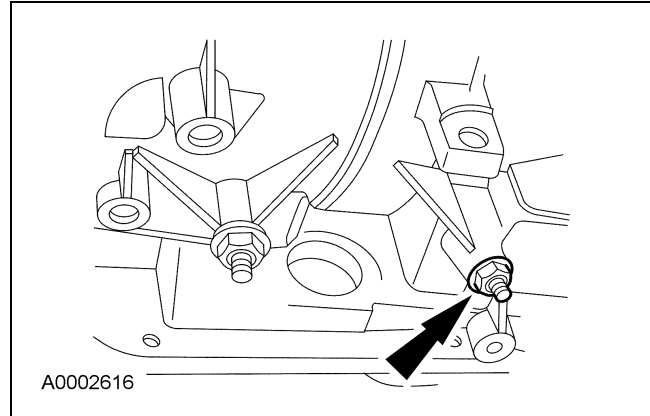

89. **⚠ CAUTION: The intermediate servo must be installed prior to band adjustment.**

Tighten the intermediate band adjustment screw. Then back off the screw exactly 1.5 turns and hold that position.

- Tighten to 14 Nm (10 lb-ft).

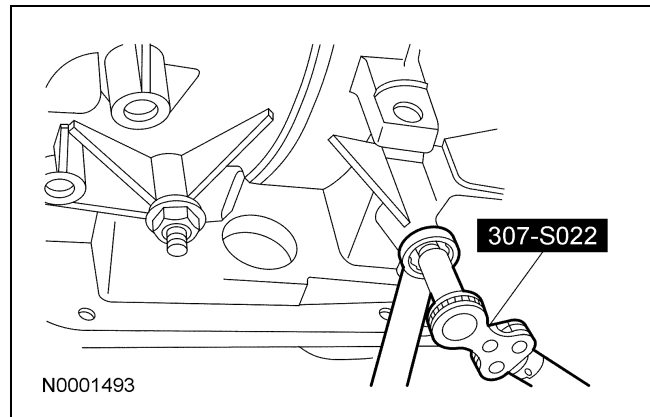

90. Tighten the intermediate band locknut.

- 1 Hold the intermediate band adjustment screw stationary.
- 2 Tighten the intermediate band locknut.
 - Tighten to 54 Nm (40 lb-ft).

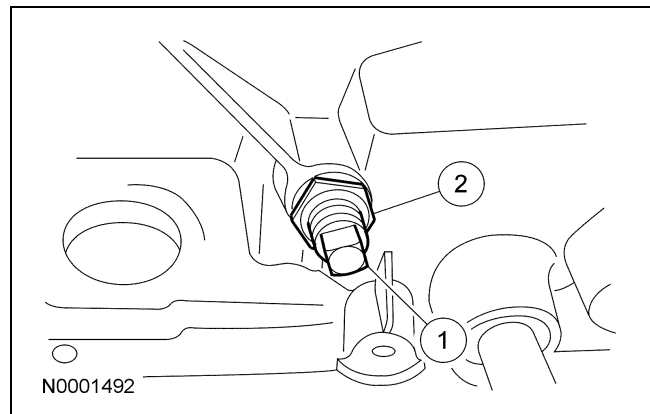

ASSEMBLY (Continued)

91. Tighten the center support screw.
- Tighten to 11 Nm (8 lb-ft).

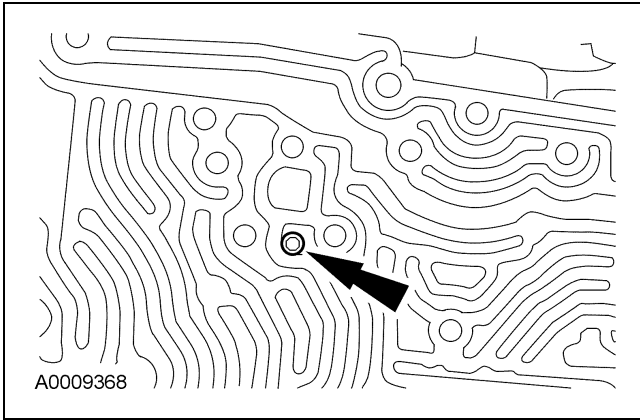

92. Using the special tools, carry out the air pressure test procedure. For additional information, refer to Special Testing Procedures in this section.

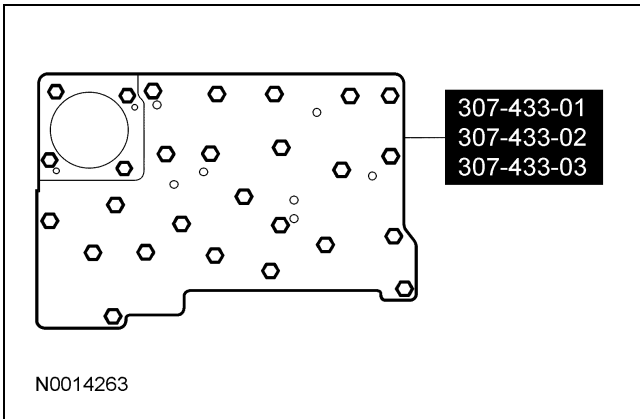

93. Install the special tools into the transmission case.

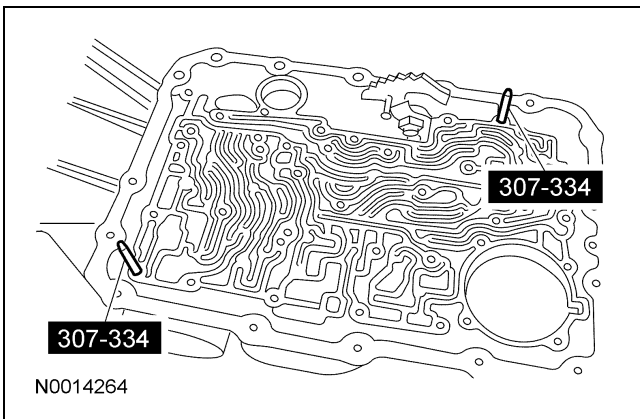

94. Using the special tools, install the main control valve body and loosely install the screws.
- 1 Install the short screw.
 - 2 Install the screw with the larger head.
 - 3 Install the remaining screws.

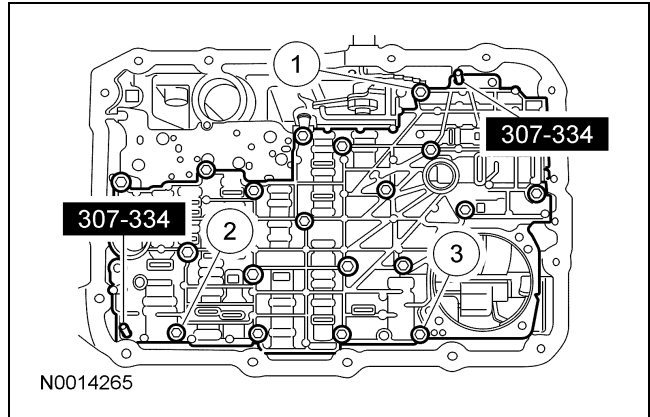

95. Remove the special tools, and loosely install the screw.

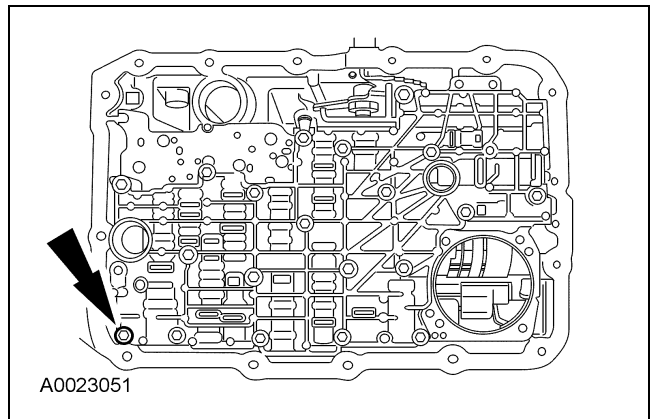

ASSEMBLY (Continued)

96. Tighten the screws in the sequence shown.

- Tighten to 10 Nm (89 lb-in).

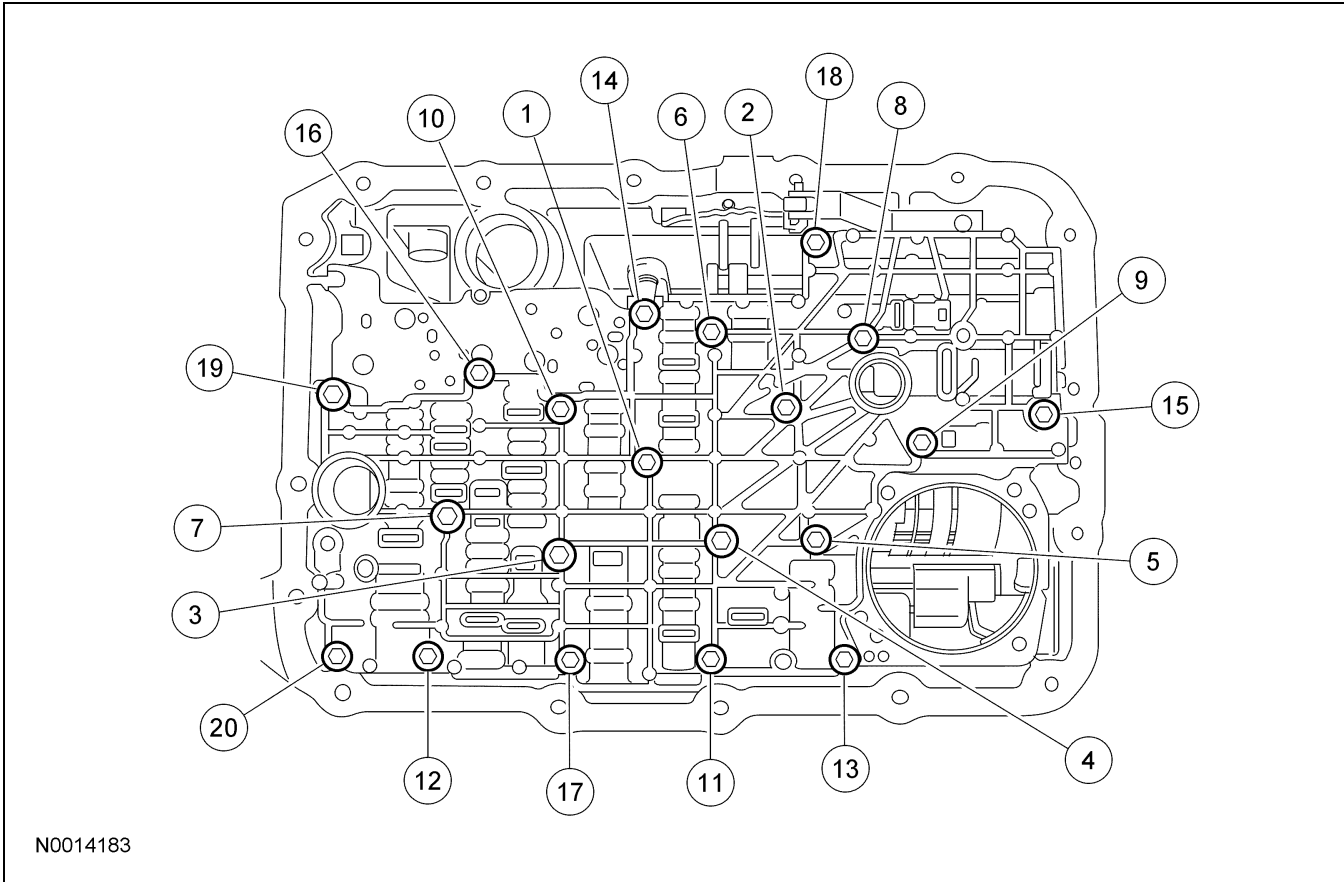

97. With the manual lever in the **NEUTRAL** position, install the manual valve detent spring.

- Tighten to 10 Nm (89 lb-in).

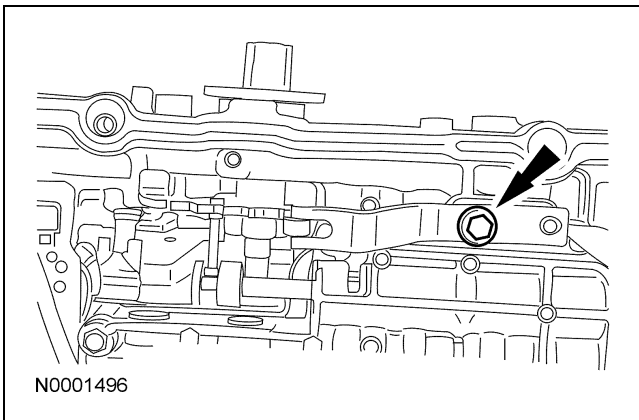

98. Install new O-ring seals on the solenoid body connector. Lubricate the O-ring seals with clean automatic transmission fluid.

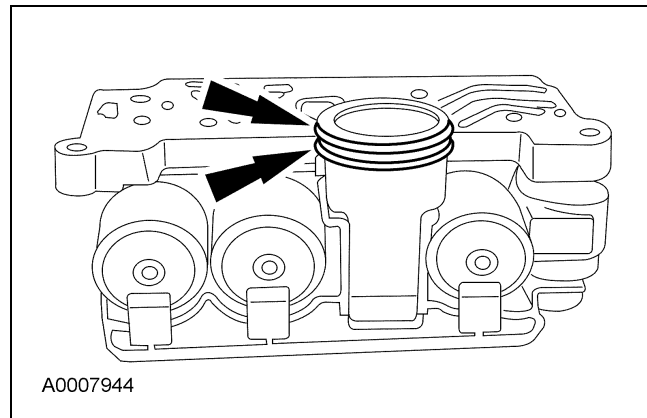

ASSEMBLY (Continued)

99.  **CAUTION:** Inspect the transmission case bore to make sure it is free of debris and not damaged. If damaged, transmission leak may occur.

Install the solenoid body. Tighten the screws in sequence shown.

- Tighten to 8 Nm (71 lb-in).

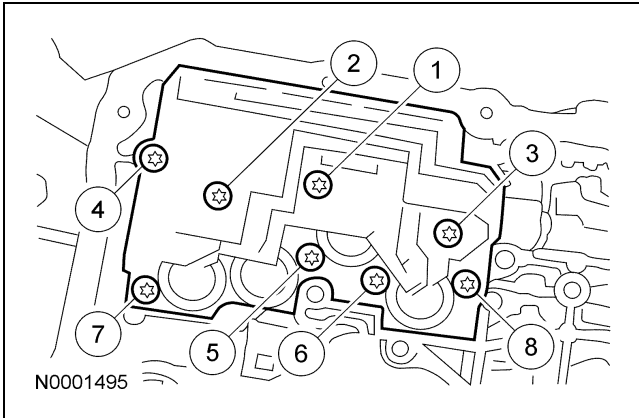

100. Install the reverse servo. Tighten the bolts in the sequence shown in 2 stages.

- Stage 1: Tighten to 5 Nm (44 lb-in).
- Stage 2: Tighten to 11 Nm (8 lb-ft).

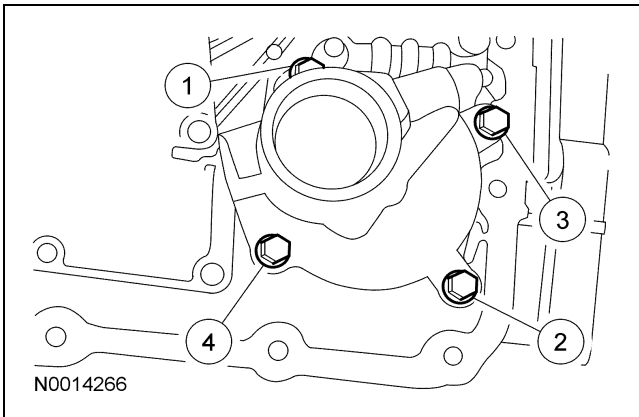

101.  **CAUTION:** Lubricate the fluid filter seals with clean automatic transmission fluid or they may be damaged.

NOTE: Make sure that the fluid filter seals are correctly seated on the filter.

Lubricate the seals and install the transmission fluid filter.

- Tighten to 10 Nm (89 lb-in).

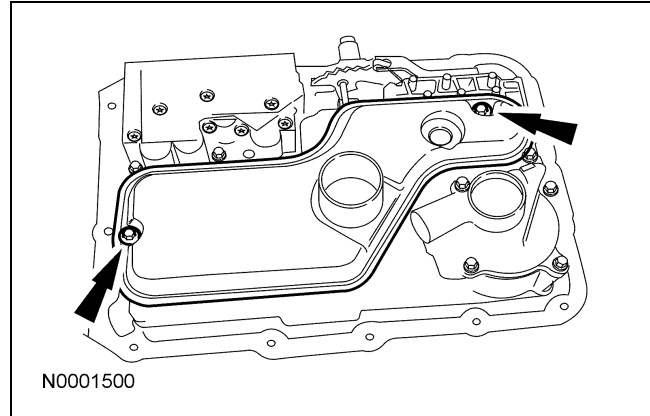

102. **NOTE:** The transmission fluid pan gasket is reusable. Clean and inspect for damage. If not damaged, the gasket should be reused.

Install the transmission fluid pan and gasket and loosely install the screws.

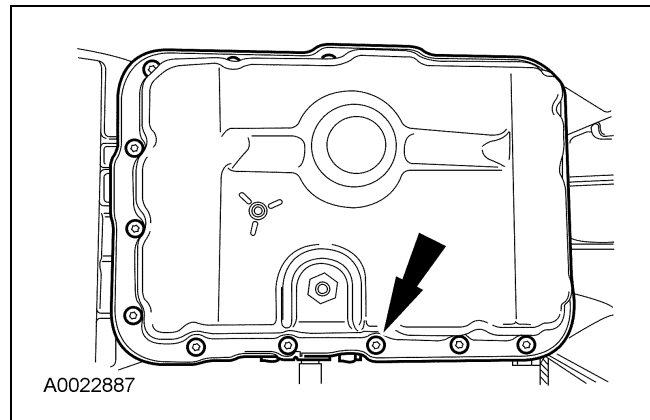

103. Tighten the 16 screws in a crisscross sequence.

- Tighten to 11 Nm (8 lb-ft).

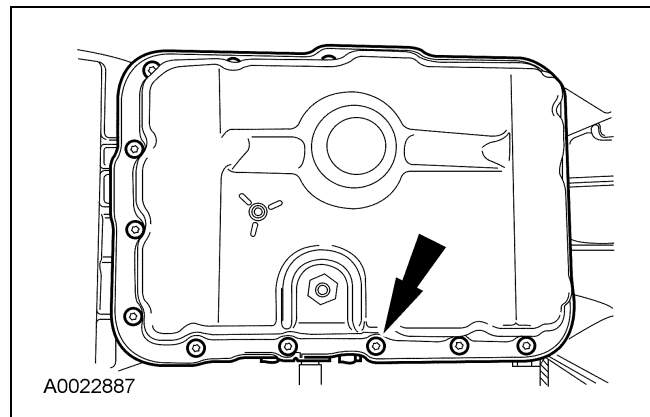

ASSEMBLY (Continued)

104. Install the parking pawl assembly and gasket.

- 1 Install the parking pawl shaft.
- 2 Install the parking pawl return spring.
- 3 Install the parking pawl.
- 4 Install a new gasket.

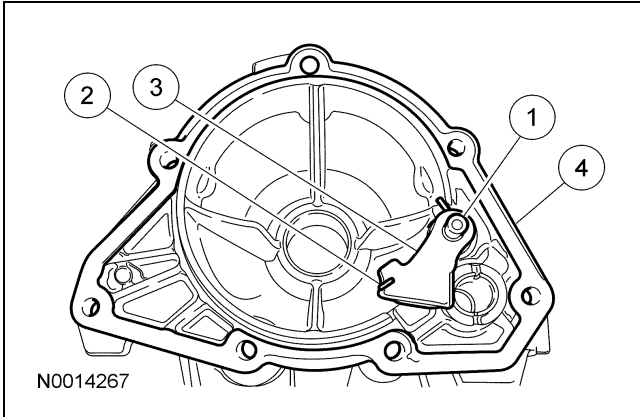

105. Install the extension housing.

- Tighten to 25 Nm (18 lb-ft).

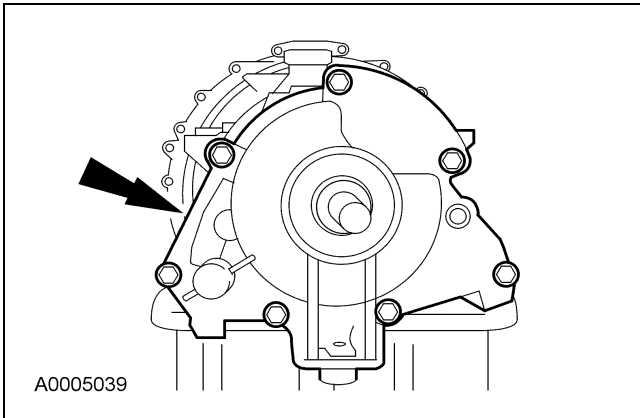

106. Using the special tool, install the extension housing seal.

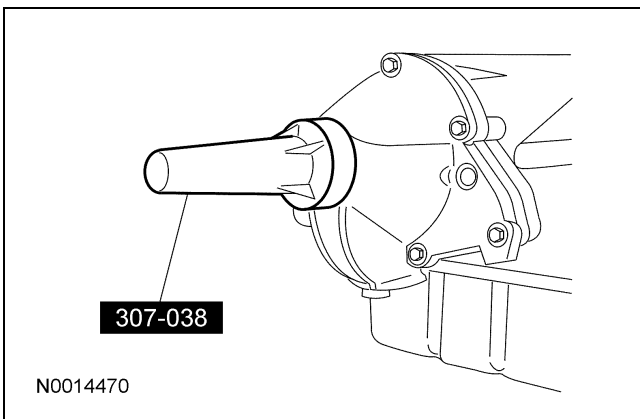

107. Using the special tools, install the output shaft flange.

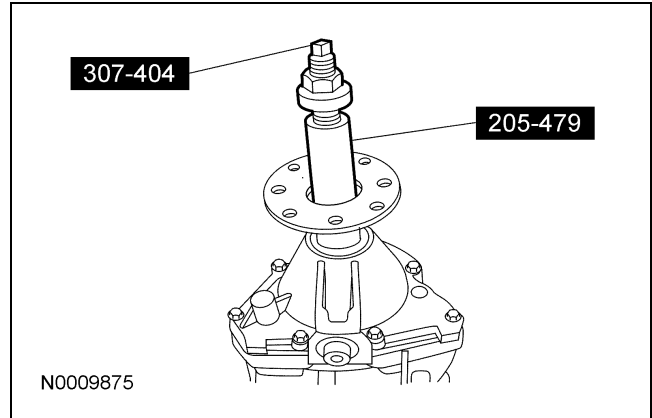

108. Install a new nut.

- Tighten to 131 Nm (97 lb-ft).

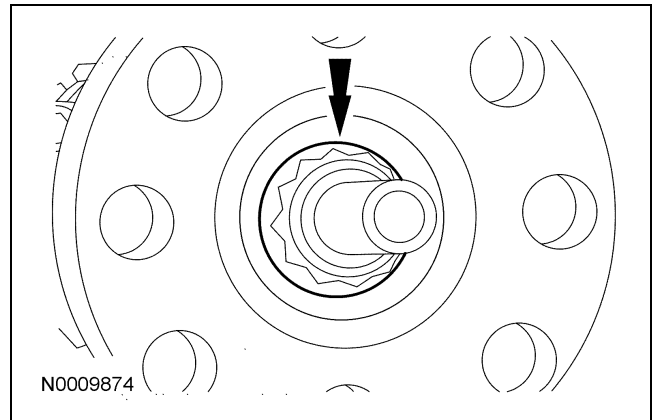

109. **⚠ CAUTION: The digital transmission range sensor must fit flush against the boss on the case to prevent damage to the sensor.**

Install the digital transmission range (TR) sensor and loosely install the screws.

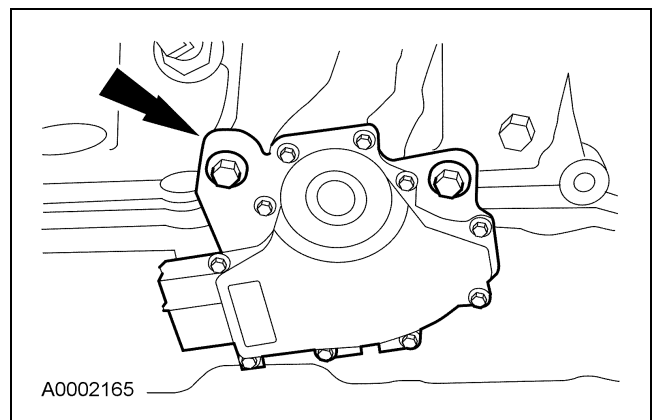

ASSEMBLY (Continued)

110.  **CAUTION:** Tightening one screw before tightening the other may cause the sensor to bind or become damaged.

NOTE: The manual lever must be in the NEUTRAL position.

Using the special tool, align the digital TR sensor and tighten the screws in an alternating sequence.

- Tighten 10 Nm (89 lb-in).

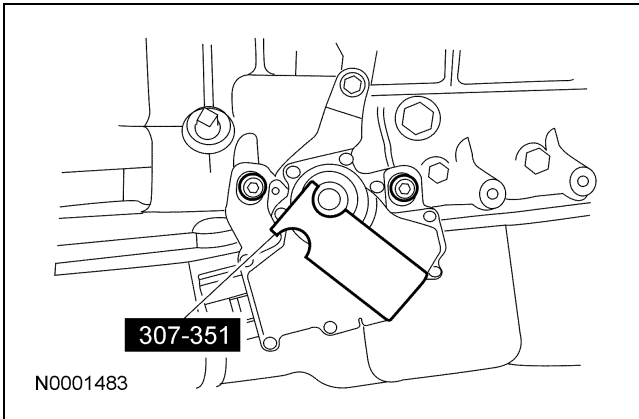

111.  **CAUTION:** The splines of the input shaft are not the same length on both ends. The shaft end with the shorter splines goes into the fluid pump.

Install the input shaft.

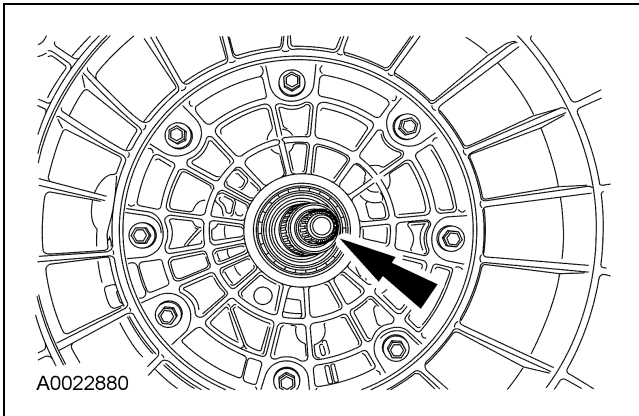

112. Using the special tool, make sure that the fluid pump gear seal ring is fully seated.

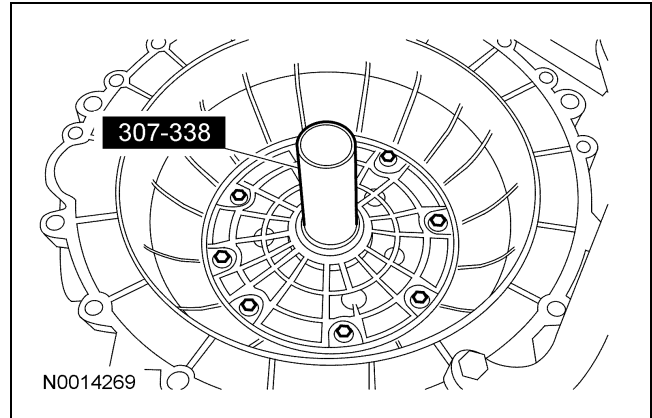

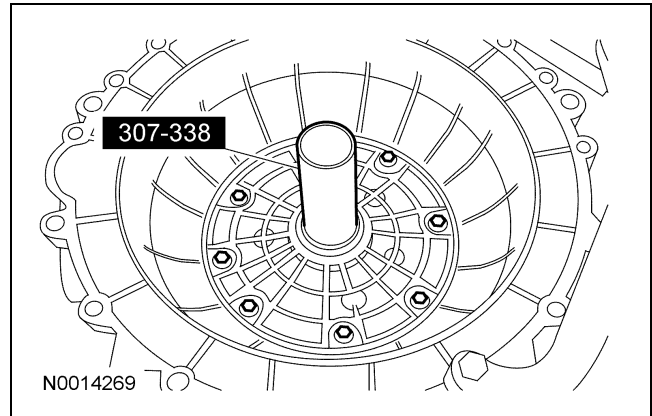

113. Remove the special tool.



ASSEMBLY (Continued)

114.  **CAUTION:** Do not damage the fluid pump gear O-ring seal when installing torque converter.

 **CAUTION:** Make sure the converter hub is fully engaged in the pump support and gear and rotates freely. Do not damage the hub seal.

 **CAUTION:** If the torque converter slides out, the hub seal may be damaged.

Lubricate the converter hub with clean automatic transmission fluid.

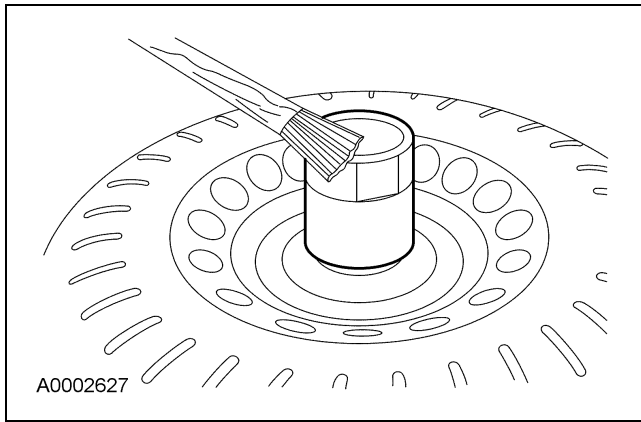
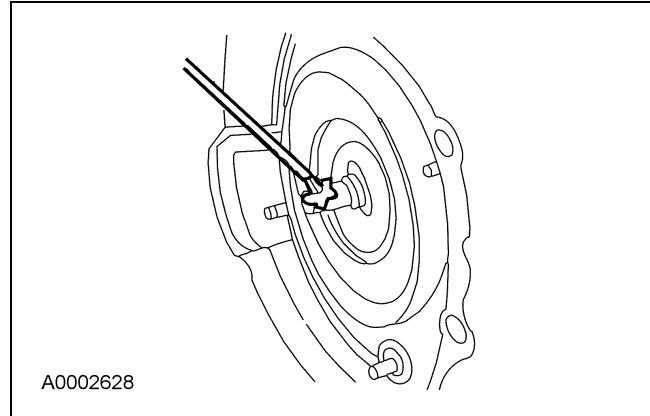

115.  **WARNING:** The torque converter can fall out if the transmission is tipped. Failure to follow these instructions may cause personal injury.

Using the special tools, install the torque converter by pushing and rotating.

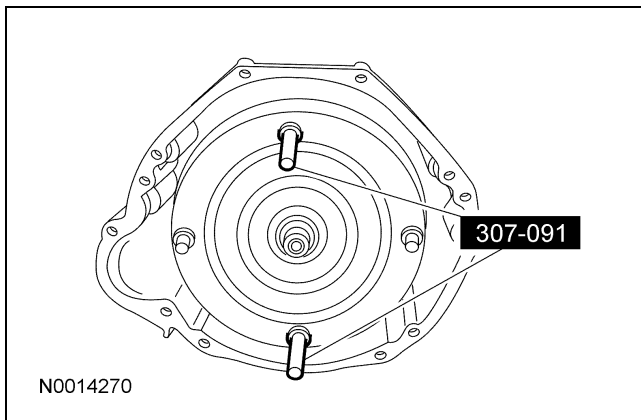

116. Lubricate the torque converter pilot hub with multi-purpose grease.

117.  **CAUTION:** The special tool must be used to correctly align the adapter plate to the converter or transmission damage could occur.

In order to correctly install the special service tool, it must be installed using one round and one oblong hole. Using two oblong holes will cause damage to the transmission.

NOTE: Position the adapter plate on the torque converter and identify the position of the orange or green paint daub on the converter face.

If the vehicle is equipped, use the special tool to install the torque converter flex plate adapter assembly and 8 nuts.

- Tighten to 44 Nm (33 lb-ft).

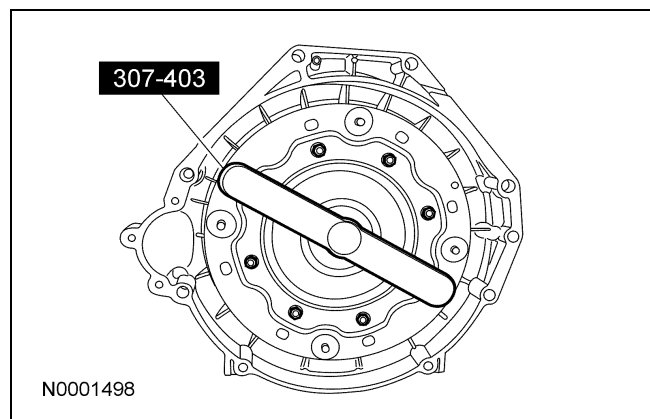

ASSEMBLY (Continued)

118. Remove the special tool and install the remaining torque converter flex plate adapter nuts.

- Tighten to 44 Nm (33 lb-ft).

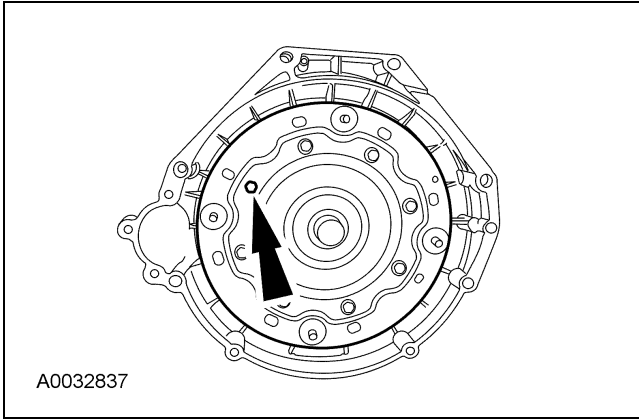

119. Using one of the speed sensor holes, fill the transmission with 8.5L (9 quarts) of automatic transmission fluid.

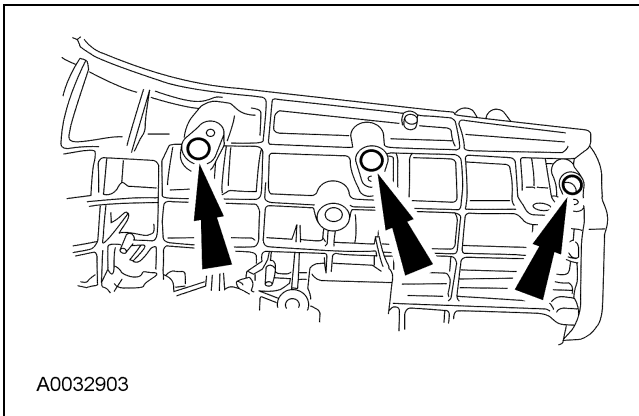

120. **NOTE:** Inspect O-ring seal for damage. Install new if damaged. Lubricate the O-ring seals with petroleum jelly to prevent damage to the O-ring seals.

Install the sensors.

- Tighten to 10 Nm (89 lb-in).

