

# Fiat Spider - 2000

1981  
owner's manual

^, ^: ^y. ^, v: ; ; -; -0 ^:  
\$\$M



FIAT

## SERVICE NETWORK

When your car needs Service look for the sign which identifies all authorized Fiat Dealers where trained personnel, specially designed equipment and facilities are available.

Our organization is at your full disposal for any Suggestion or advice you may need.

## SPARE PARTS

Authorized FIA T parts are the best guarantee for top Performance and satisfactory Operation of all components.

When ordering, please quote (see page 2) :

- Car Model.
- Number for Spares.
- Part Number(s) of Spare(s) Ordered.

## BREAK-IN RECOMMENDATIONS

Current progress in design and manufacturing technology is so advanced that no hard-and-fast rule need be given for break-in. However, a few simple rules should be followed for the first 1000 miles:

- Avoid fierce accelerations soon after starting and allow time for the engine to warmup (a good habit even after break-in).
- Do not fully depress the accelerator pedal and avoid high engine speeds, when operating in the lower gears, that is, never allow the tachometer pointer to move into the yellow sector indicating high rpm rates.

- Change your road speed occasionally, especially on long trips. Avoid long drives at constant high or low speeds,
- Downshift whenever necessary to cope with driving conditions on route: you will avoid engine lugging at excessively low rpm.
- Avoid, if possible, severe stops at sustained speeds during the first few hundred miles: brakes will set properly and improve their life and effectiveness.

Remember that satisfactory Operation and long life are dependent to a great extent on the care with which the car is handled during break-in.

# ***Fiat Spider 2000***

*This Manual provides the Information necessary for satisfactory Operation and maintenance of your car.*

*We wish you pleasant motoriny and trust the Information providedsd will help to ensure the fang Ufe and safety of your car.*

***Operation*** ■ ***maintenance*** ■ ***specifications***

# KEYS

Each vehicle is provided with two keys in duplicate; quoting the number stamped on each key is essential to obtain a replacement from FIAT's Sales Organization.

A For ignition switch

B For door and trunk locks.

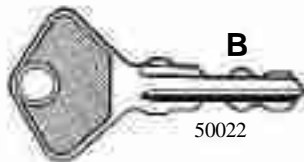
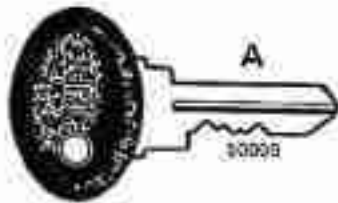

# IDENTIFICATION DATA

## • Manufacturer's Plate

A - Name of manufacturer

B - Vehicle identification code

C - Chassis Number

D - Engine type

E - Version code

F - Number for spares

G - Space reserved for Diesel vehicles

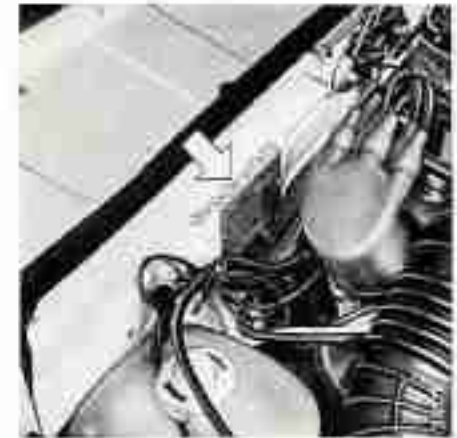
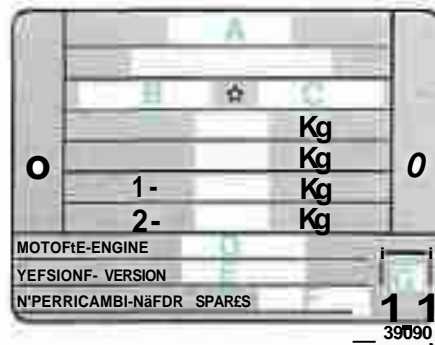

- **Engine Type (132 C3.031) and Identification Number** - Punched on crankcase, near oil filter mount.

- **Chassis Type (124 CS2) and Identification Number** - Punched on engine compartment bulkhead (permanent structure) right side.

- **F.M.V.Safety Standard 115Tag** Type of vehicle and chassis number, located on panel top between instrument cluster and windshield.

- **F.M.V.Safety Standard 110Tag** Tire data and car capacity, located on R.H. door pillar, above striker.

- **A) F.M.V. Safety Standard Conformity Tag** - Month and year of manufacture, gross vehicle weight rating, gross axle weight rating, chassis number and car type, located on left door pillar.

- **B) Vehicle Emission Control Information Label** - Located on left door pillar.

- **E.P.A. and California Regulations Conformity Tag** - Air pollution control specifications for correct engine tuneup and adjustments, located in engine compartment, on cowl.

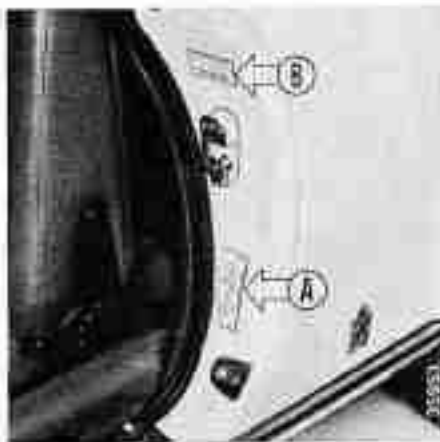
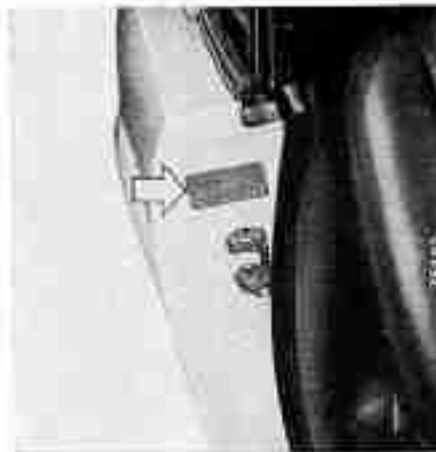

1 2 3 4 5 6 7 8 9 10 11 12 13 14 15 16

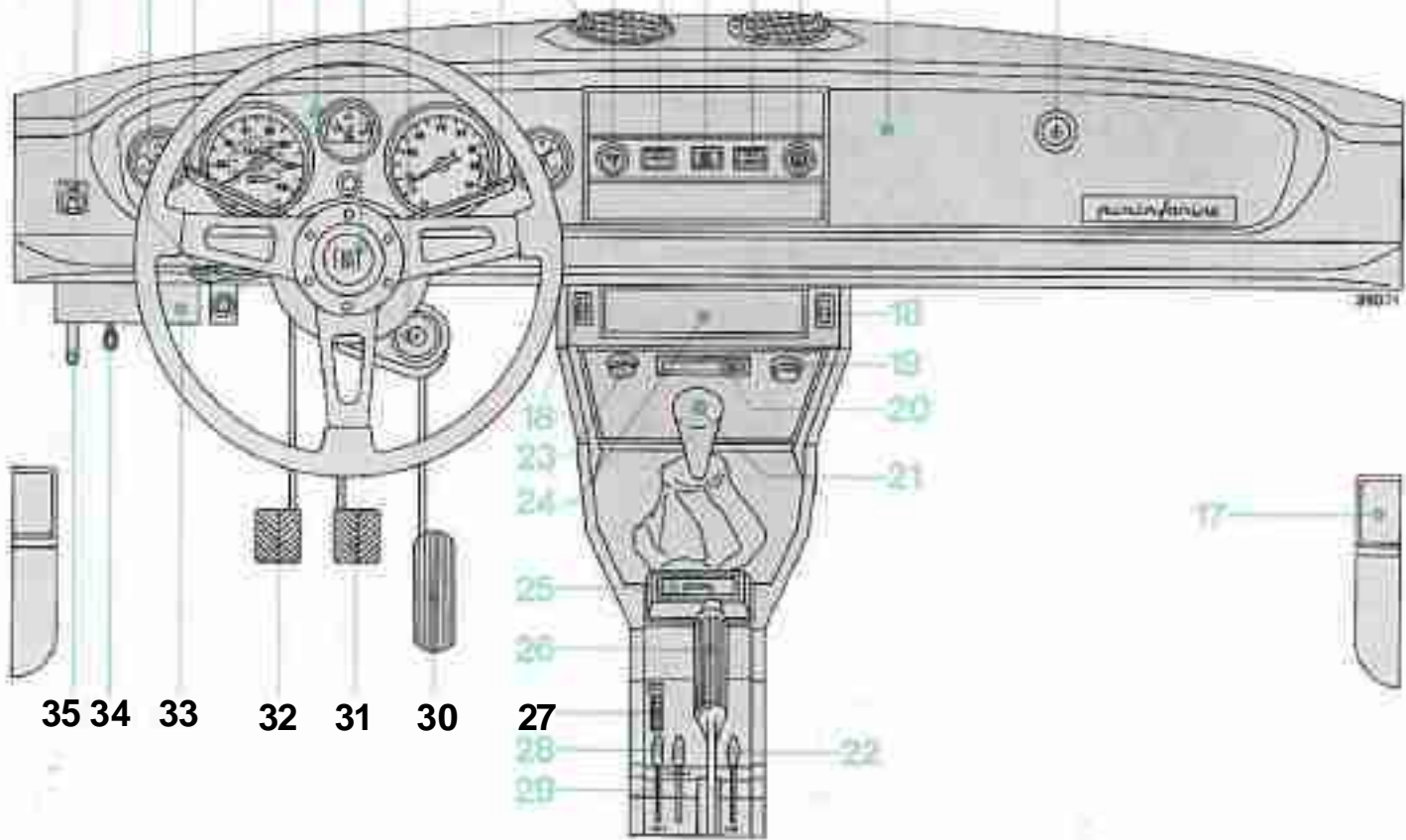

# ***INSTRUMENTS AND CONTROLS***

- |  |   |  |
|--|---|--|
| 1 lighting switch, three-position                          | 13 Fasten belts indicator   | 24 Optional radio housing blanking lid                                       |
| 2 Turn signal lights switch level                          | 14 Knob switch and rheostat for instrument cluster lighting       | 25 Ash tray  |
| 3 High/Low beams change-over switch lever                  | 15 Glove compartment  | 26 Hand brake lever. To release the lever press in button on top of handgrip |
| 4 Inspection lamp receptacle                               | 16 Glove compartment lock   | 27 Two-speed heater fan switch, three-position                               |
| 5 Instrument cluster                                       | 17 Utility recesses (two)   | 28 Air volume control lever  |
| 6 Horn button  | 18 Power window switches housing                                  | 29 Air temperature control lever   |
| 7 Steering lock ignition switch                            | 19 Courtesy light with switch                                     | 30 Accelerator pedal   |
| 8 Windshield washer and wiper switch lever, three-position | 20 Vehicular hazard warning signal indicator and switch           | 31 Service brake pedal   |
| 9 Air outlets  | 21 Gearshift lever  | 32 Clutch pedal  |
| 10 Windshield wiper sweep rate knob                        | 22 Lever controlling air flow through outlets 9 and/or under dash | 33 Fusebox   |
| 11 Low brake fluid level/hand brake ON indicator           | 23 Cigar lighter  | 34 Hood release emergency cable  |
| 12 «EX. GAS SENSOR») indicator                             |   | 35 Hood catch release lever  |

# OPERATION

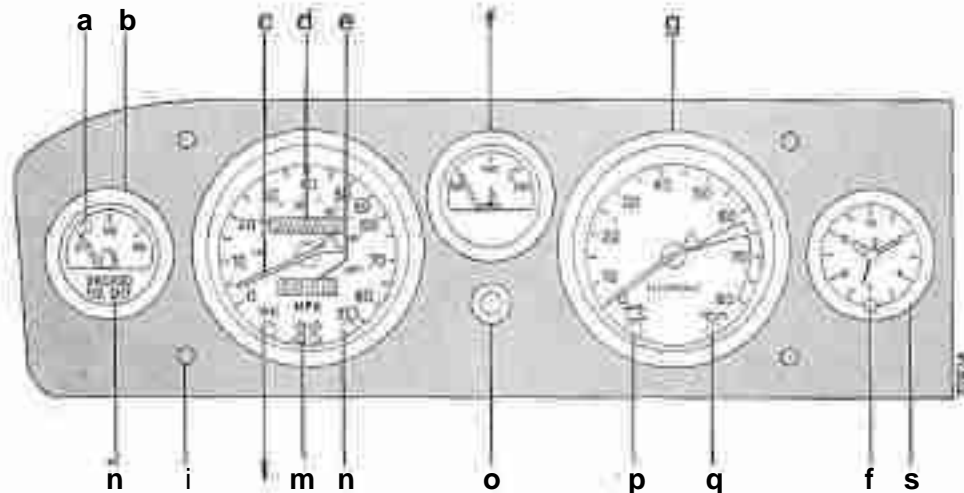

## Instrument Cluster

- a) **Fuel Reserve Indicator (Red)** - Warning that the fuel supply available in the tank is between 5 and 7.5 liters {17<sub>3</sub>to2 Gals).
- b) **Fuel Gage**
- c) **Speedometer** - This instrument (which includes the odometer) is factory-sealed: any tampering by unauthorized persons will invalidate the warranty.

## d) Odometer (Totalizer)

## e) Trip Recorder

- f) **Engine Water Temperature Gage** - If the pointer enters the red area it means that the engine is overheating: it will then be necessary to immediately rev down the engine to idle speed (do not switch off). Should the pointer remain on the red area, contact the nearest

FIAT Dealer for a cooling system check (including fan circuitry).

- g) **Tachometer** - Electronically-operated from the ignition distributor. The yellow area indicates maximum engine speed for all gears whereas the red area shows dangerous engine operating speeds.

## h) Type of Fuel Used (see page 33)

## i) Cluster Panel Mounting Knobs (Four)

## l) Parking and Tail Lights Indicator (Green)

## m) Turn Signal Arrow Indicator (Flashes green)

## n) High Beams Indicator (Blue)

## o) Trip Recorder Zeroing Knob - Turn knob clockwise but **never** when car is running.

## p) Battery Charge Indicator (Red) With engine inoperative, and ignition key in position MAR, the charge indicator is on and must go out when engine is started;



should indicator turn on while engine is running, this is a warning of a fault in the battery re-charging system: turn immediately to a FIAT Dealer for assistance.

**q) Insufficient Oil Pressure Indicator (Red)** - The light should go off when oil pressure is sufficient to ensure adequate engine lubrication,

**r) Clock Reset Knob** - Push and turn clockwise making sure that it springs back when released.

**5) Quartz Crystal Clock**

### Lighting Switch

*Up* = All lights OFF.

*With Ignition Key at MAR:*

*Down* — Parking and tail lights, headlight low or high beams and flashers (main beams).

*With Ignition Key Removed:*

*Center* (night parking only) = Parking and tail lights.

*Down* = All lights OFF.

**Fasten Belts Indicator (Red) and Buzzer** - Both are operative for a few seconds when a starting attempt is made with seat belts (driver and/or passenger) unfastened.

**Low Brake Fluid Level/Hand Brake ON Indicator (Red)**

With ignition key at MAR the indicator lights up to warn the driver that the bulb is efficient. In case the indicator remains ON it means either that the hand brake lever is pulled upwards (brake applied) or that the brake fluid level is too low.

Should the indicator turn on while the vehicle is moving, stop and check the fluid level in reservoir. If the level is too low, great care should be taken when applying the brakes and the nearest FIAT Dealer contacted for a brake system check.

**Vehicular Hazard Warning Signal Switch** - Turns ON (independently of key position in lock switch) the front and rear turn signal lights which will all flash simultaneously to warn of the presence of the vehicle stopped on the road.



38003

### EXHAUST GAS SENSOR INDICATOR (red)

Lights up:

- **Every 30 000 miles** to warn owner of need to replace exhaust gas sensor (Lambda probe);
- On starting; it should go out when engine is started.



**Steering Lock Ignition Switch (\*)**  
 (See page 16 for starting procedure instructions)

**MAR (Run)** = Engine ignition ON and accessories energized

**AW (Start)** = Engine starting

**ST (Stop)** = Steering post anti-theft lock in. Key removable

The total or partial removal of key will lock the steering post even if car is in motion. To facilitate the disengagement of steering post lock, slightly rock the steering wheel while rotating the key. Key must not be left in position MAR when engine is inoperative and must be removed only when leaving the car, especially if unattended.

(\*) Even with key removed (position ST) the following circuits are still energized : courtesy lights; horns; cigar lighter and housing indicator; vehicular hazard warning signal; remove key buzzer; clock; inspection lamp receptacle.

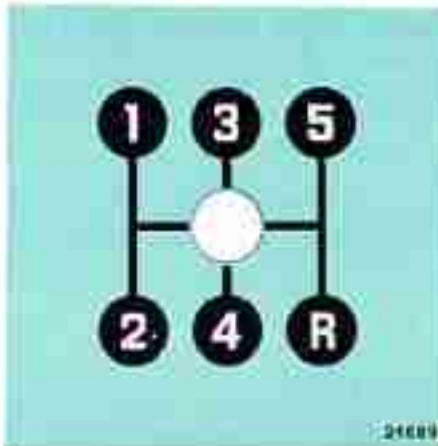

**Remove Key Buzzer** - Operates when the steering wheel side door is opened to leave the car and the ignition key is forgotten in the lock switch.

**Gearshifting Pattern** - To engage reverse (R), press the lever and shift as indicated by the gating pattern.

**Note:** The use of fifth gear over 4B mph improves fuel economy.

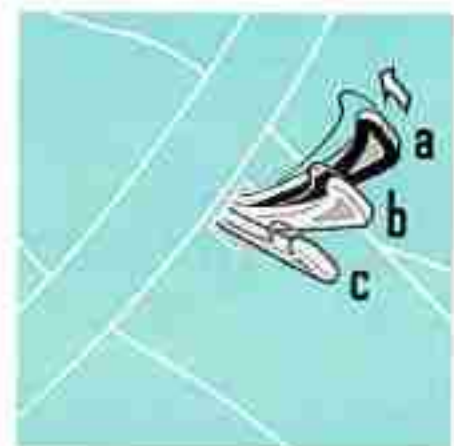

**Windshield Wiper/Washer Switch Lever**

**a** = Wiper off

**b** = Wiper On-Off intermittently (particularly useful in drizzly weather)

**c** = Wiper on continuously

Lifting the lever towards steering wheel, whatever its position, will switch on the washer.

**Windshield Wiper Sweep Rate Knob**

- Provides high or low sweep rates in either wiper continuous or intermittent operation, depending on the position of wiper lever switch.

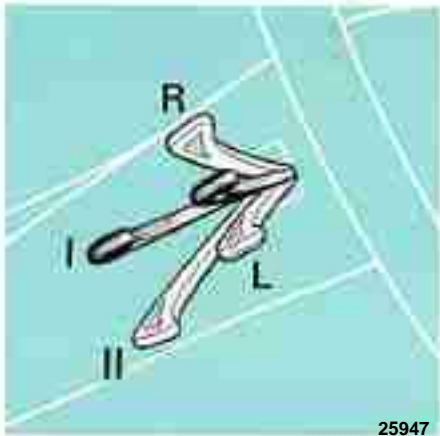

**High/Low Beams Change-Over Switch Lever** {With lighting switch down and ignition switch at MAR}

- I = Low beams
- II = High beams

By lifting the lever towards steering wheel headlight high beam flashes are obtained even with all lights out (Daylight signals).

**Turn Signal Lights Switch Lever**  
Automatically trips back to OFF.

R = Right turn     = Left turn

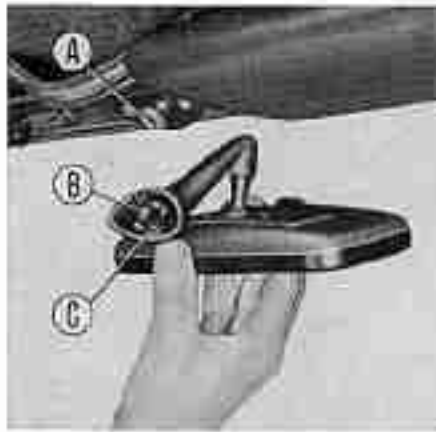

**Inner Rear View Mirror** - Collapsible, with anti-glare (Day/Night) position controlled by a lever. If the mirror comes off its seat, following an impact, refit by engaging spring B on stud A — make sure the two location dowels are properly registered with relevant seats — and press on base C. Engagement is of the snap-on type.

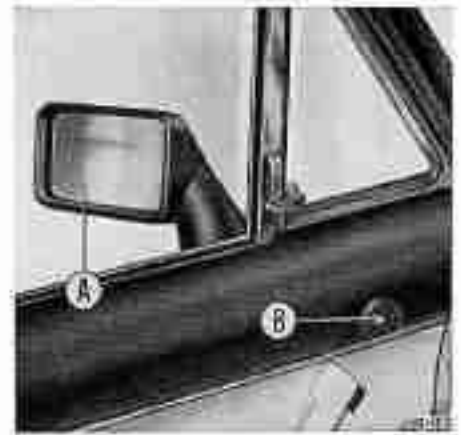

**Outer Rear View Mirror** A on steering wheel side door is adjustable from driver's seat, by means of lever B.

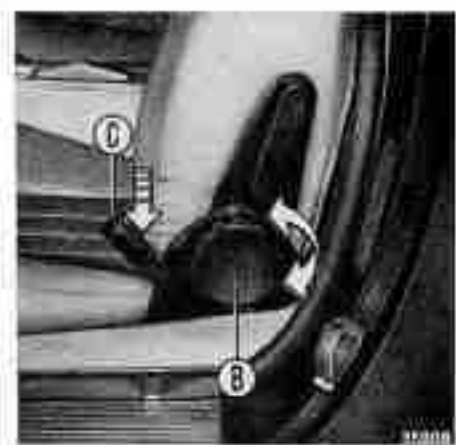
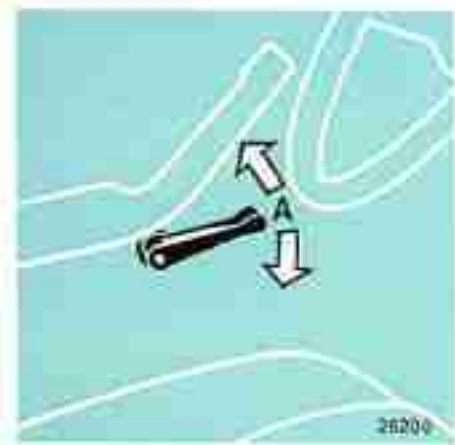

## DOORS

### Opening

**From outside** - Unlock and pull the handle.

**From inside** - Pull up lever **A**.

### Locking

**From outside** - Both doors are provided with key-operated locks. Stepping out of the car on the curb side is thus also possible. Always use the key; never lever **A**.

**From inside (safety latch)** - With door already shut set the lever **A** down. The lever will thus first insert the safety latch and then snap back to rest.

**Note:** Lubrication of lock cylinders is not recommended. At most, blow some graphite powder into the cylinder keyhole. In cold climates it is recommended to squirt in some special antifreeze fluid for locks. Repeat the operation every time the car is washed or at least every 15 days, if insertion of key in the frozen lock proves difficult, simply warm up the key.

## SEATS

Seats may be adjusted for leg reach after moving control lever **A** downwards.

Once the desired position is found, release the lever and make sure the seat has locked.

The position of the backrest is adjusted by turning knob **B**.



For access to the rear compartment push down lever C and tilt backrest downward.

On top of each seat backrest is fitted a headrest: to re-set height pull up or push down as required.

The headrest must be adjusted so as to support the head and not the neck of the occupant.

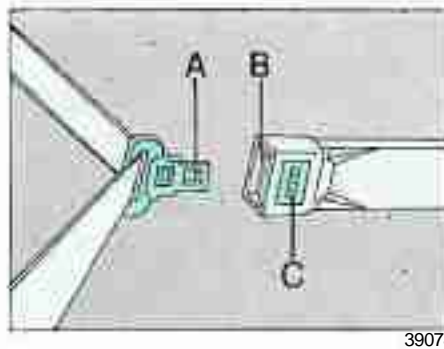

## **SEAT BELTS**

Seat belts provided as standard original equipment are of the 3-point lap type.

Pull belt fully out from retractors without stopping as otherwise it will be necessary to return the belt to the stowed position to release the retractor stop mechanism.

To fasten, fit tongue A into buckle B until a sharp click is heard.

Adjust the belt snugly around the hips, not the waist, allowing excess webbing to be pulled back into retractor.

To free yourself from the belt restraint: simply press in buckle button C.

## **Warning**

Before fastening the belts make sure the seats and headrests are properly positioned.

Each belt is intended for use by one adult or one child over 6 years of age.

Occasionally, check that webbing is in good condition.

In the event of an accident even if the belt you were wearing is apparently undamaged it is suggested that you replace it with a new belt assembly of the same type.

To keep belts clean, wash only, using warm water and mild soap. Rinse and dry thoroughly. Do not use strong detergents and avoid any chemical that may weaken the equipment.

Users are warned to consult the Manufacturers in case of doubt and not to make any alterations of, or additions to, seat belt assemblies and/or anchorages.

## VENTILATION AND HEATING

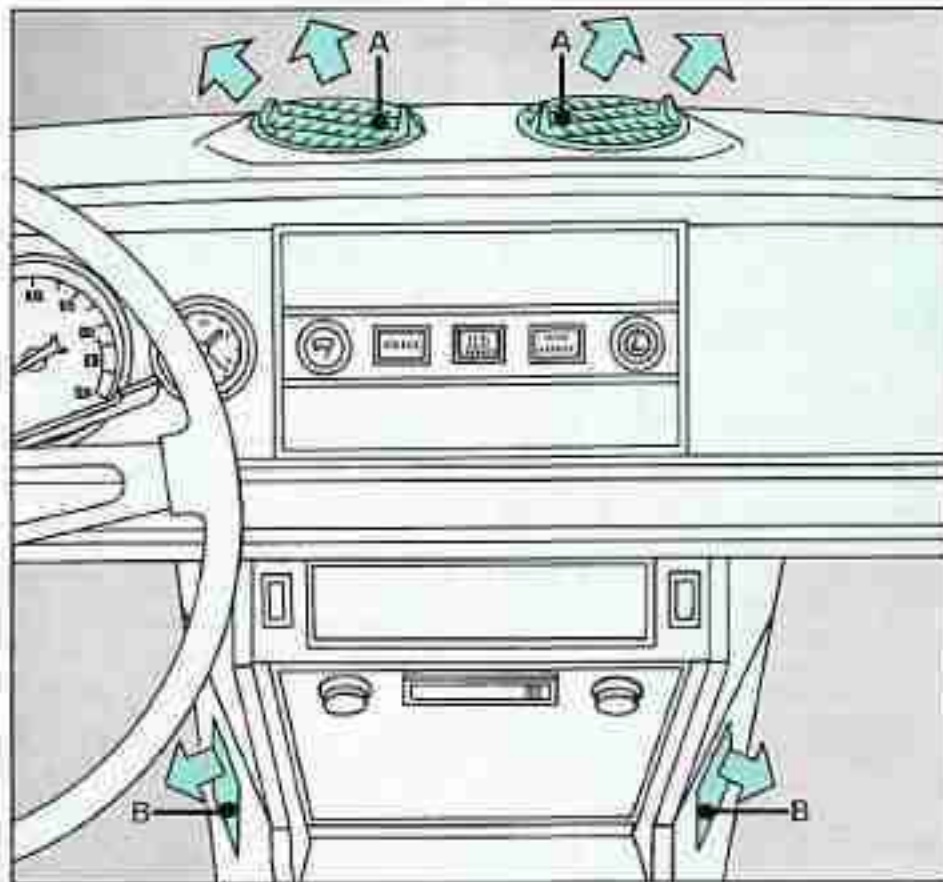

Ventilation and heating are adjustable according to seasonal requirements.

To ensure best comfort to occupants it is important to become familiar with system controls and operation.

### **Admission of Heated or Fresh Air**

**Heater fan switch C** is energized only when ignition key is in position MAR.

*Pressed in forward* = High speed

*Intermediate position* = Off

*Pressed in backward* = Low speed

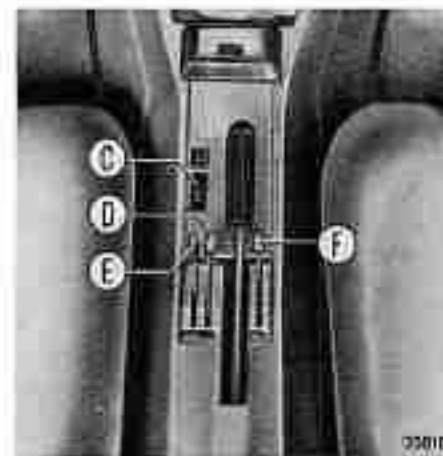

39068

**Lever D** controls the air temperature.

*Pulled all back* - No heating of air

*Pushed all forward* - Maximum heating of air

**Lever E** controls the air volume.

*Pulled all back* - Maximum air flow

*Pushed all forward* - No admission of air

Intermediate positions are used especially when outdoor temperature is low to limit the flow of cold air around heater core.

**Lever F** controls the amount of air flowing through windshield outlets A and into front lower area through console outlets B.

*Pulled all back* - Air flows through outlets A only

*Pushed all forward* - Air flows through outlets A and B

## ***Defrosting end Demisting***

For quick defrosting of windshield, pull back completely lever F, push forward lever D and set lever E in an intermediate position. Turn on the heater fan by switch **C**.

**Door window ventilators** are opened by pulling lever G and turning upward lock H.



## ***Frost Precautions***

If during cold weather the car must remain inactive for some time at freezing temperatures and the cooling system is not protected with antifreeze mixture, it will be necessary while draining the radiator and Jackets to empty also the heater core by shifting lever D all forward.

Note: If heating proves inadequate, operation of the thermostat on the line from cylinder block to radiator must be checked.



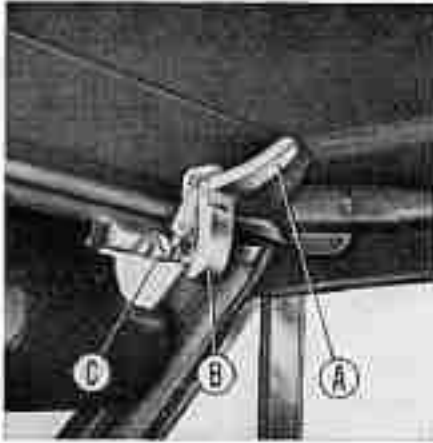

## FOLD-AWAY TOP

To lower the folding top, proceed as follows:

- Wind down the door windows.
- Pull down the two latch levers A and release clamps B from latches C securing the top to windshield frame.

- Push the top to the rear, making sure the back window is not pinched by the metal frame.
- Free the rubber strap from the peg on body side and strap the folded top as shown in the figure.



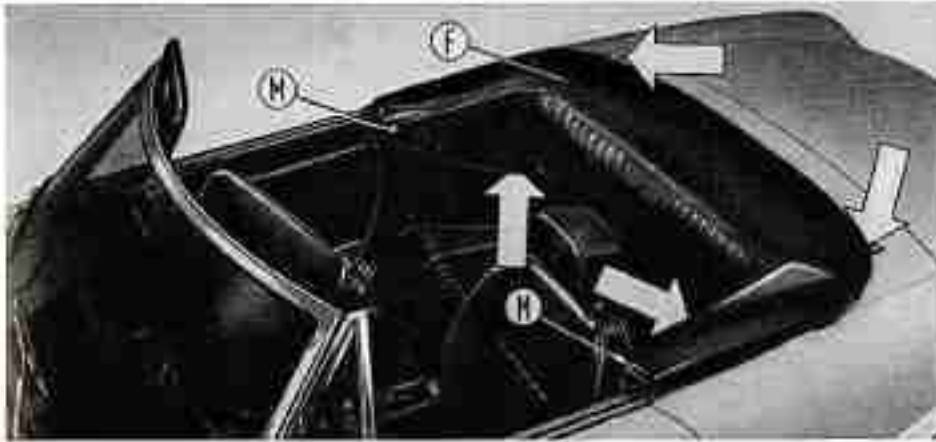

— Place cover F on the folded top well by fitting rear eyelets D on hooks E (page 14) then catches G

in detents H, spring hooks I in holes L and snap on the button fasteners M.

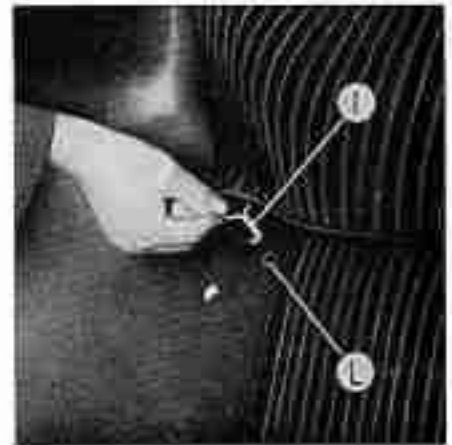

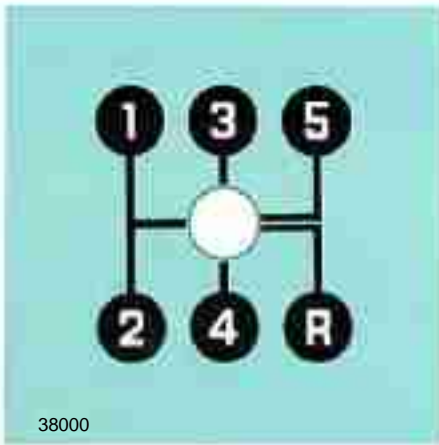

## **STARTING THE ENGINE**

### ***Cold Starts With Manual Transmission***

- Move gearshift lever to neutral.
- Depress clutch pedal, especially in cold climates.
- Insert and turn ignition key clockwise to the stop, that is position **AW**. As soon as engine is started release key which will snap back to position **MAR**.

Should the engine fail to start return ignition key back to **ST** position and repeat starting attempt.

- Do not step on accelerator pedal until the engine is running smoothly.
- Avoid sudden acceleration when engine is cold.

Do not continue with repeated starting attempts. If the engine fails to start or stalls at idling have the fuel injection and ignition systems checked as soon as possible.

### ***Cold Starts With Automatic Transmission***

Move the selector lever to HI or P. Engine starting is not possible with the selector lever in any other position.

Then proceed according to manual transmission instructions.

### ***Hot Starts***

For vehicles with manual and automatic transmission turn ignition key without touching accelerator pedal.

## ***DRIVING THE CAR***

Never maintain nor exceed the maximum allowed speeds and do not drive with tachometer pointer steadily on the yellow sector.

Do not travel steadily for long intervals at top speed in any gear.

All red indicator lights should be out while driving.

Do not coast downhill with the clutch pedal depressed, the transmission in neutral or the engine off, as the marginal saving in fuel consumption which may be derived from such practice does not compensate for the resulting loss in brake lining life and driving safety which is provided by the braking effect of the engine.

Remember that upon switching off the engine, the brake servo is deactivated and, therefore, braking requires more effort.

Do not allow the engine to lug, particularly when driving up steep hills, but shift down in good time to benefit from maximum engine pulling power.

Do not ride the clutch, otherwise slippage and damage will result.

Ensure that both the foot and hand brakes are efficient at all times. After a car wash apply the foot-brake a few times so as to restore full brake effectiveness.

Always apply the foot brake progressively. Remember that wheel locking, especially with an unladen car, will result in dangerous skidding. In case of emergency the hand brake may be used to stop the car.

On wet or slippery roads hard braking will increase the likelihood of wheel locking and consequent inevitable loss of handling control. Instead, use the engine braking effect by

engaging a gear lower than would normally be required. Braking, if absolutely unavoidable, should be gentle and progressive and, in any case, simultaneous with engine braking.

On icy roads drive slowly, turn the steering wheel very gently, avoid using the brakes, change gear smoothly and do not drive with the clutch pedal depressed. If the car starts skidding release the accelerator pedal, do not brake, but steer smoothly in the direction of skid; as the car regains its course straighten the wheels and accelerate gently.

Always use tire chains or snow tires before starting a journey on ice or snow covered roads and remember that while snow chains can be fitted to the driving wheels only, studded tires should be fitted to all wheels.

When driving in mist or fog during daylight switch on the parking and tail lights: do not use the high beams.

Before turning or changing lanes, in addition to giving the correct signals glance in the mirrors to ascertain the intentions of the drivers behind you. Before cutting back into your lane after overtaking a vehicle wait until it appears in your inner mirror.

At night when meeting oncoming traffic, keep your eyes on the right side of the road rather than looking straight into the approaching headlights or other light sources: you will avoid being blinded.

## ***PARKING***

Always apply the hand brake when parking and if on a grade, for added safety also shift into first or reverse depending on whether the car is heading up- or downhill.

When the car is left in dark areas always turn on the parking lights: lighting switch pressed halfway in at bottom.

## ***RECOMMENDED SHIFTING SPEEDS***

1st-2nd	2nd-3rd	3rd-4th	4th-5th
15 mph	25 mph	40 mph	45 mph

**Note:** In any case the maximum speed listed on page 62 should never be exceeded.

# **AUTOMATIC TRANSMISSION**

*(Optional Extra)*

## **OPERATION**

To obtain any ratio move selector lever A to the desired position.

When shifting from P to R, R to P, N to R, D to N or 2 to 1 lift trigger B simultaneously. When shifting from D to 2 and viceversa do not operate trigger B, Light C indicates the selected position.

### **Selector Lever Positions**

P. Park - R. Reverse - M. Neutral -  
D. Drive - 2. Intermediate - 1. Low.

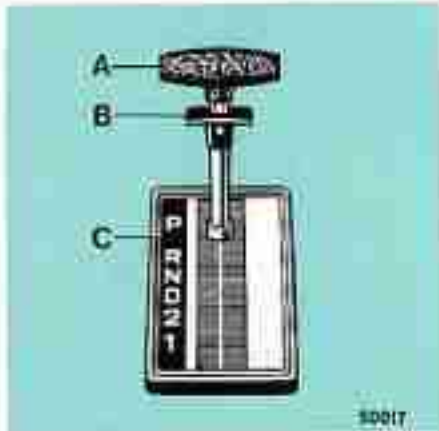

### **Selector Lever Positions**

#### **P Park**

In this position the transmission is mechanically locked but engine starting is possible. Park should not be selected when the car is in motion or stationary in busy car parks where shunting is likely to occur.

Use of the Park position is recommended when parking on flat and sloping ground and before servicing.

#### **R Reverse**

To select Reverse bring the car to Q dead stop and release the accelerator pedal (engine idling).

#### **N Neutral**

In this position the engine can be started.

#### **D Drive**

This position is used for normal driving.

The transmission starts in low gear and automatically changes up or down at suitable road speeds according to the position of the accelerator pedal and the demands made by the driver. For quick down-shifting depress the accelerator pedal through its hard spot (kickdown position).

Kickdown permits down-shifting from third to second below 59 to 64 mph or into first below 31 to 34 mph.

Normal change-down from D to 2 and D to 1 can be obtained by means of the selector lever below 70 mph and 43 mph respectively, without depressing the accelerator pedal.

#### **2 Intermediate**

Operation is as described under D but no up-shift into third is possible. This may be advantageous when driving over hilly or difficult roads requiring

consistent pull and moderate engine braking.



### **Low (Lock-up in First)**

To be selected when driving up and down very steep hills, especially with a trailer on tow, and when maximum engine braking is desired.

When the selector lever is moved to 1 the transmission changes to, and remains in first, regardless of engine speed.

**Note:** With the engine idling and D, 2, 1 or R selected the car may tend to creep forwards or backwards. This tendency can be obviated by lightly applying the foot brake and may well be advantageous for difficult parking maneuvers.

### **Starting**

Before starting the engine move the selector lever to N or P.

Engine starting is not possible with the selector lever in any other position.

Starting instructions not described here are as given on page 19.

Depress the brake pedal without accelerating at all, and move the selector lever to 1, 2, D or R as desired.

Release the hand brake and the foot brake.

Depress the accelerator pedal progressively. In D the car will move off in first gear and automatically change up as speed is increased,

For maximum acceleration depress the pedal through its hard spot. This causes up-changes to occur at higher road speeds than under part-throttle driving (approximately 40 to 43 mph from first to second and approximately 65 to 70 mph from second to third).

Exceptionally, when maneuvering in confined areas or for hill-holding the driver will find it convenient to use the left foot on the brake pedal and, using this pedal in conjunction with or without the accelerator pedal, a high degree of control is obtained.

During normal driving both the accelerator and the brake pedals should be operated with the right foot only.

### **Towing by Another Vehicle**

Proving the transmission is operating satisfactorily, the car may be towed in N over distances up to

30 miles and at road speeds not exceeding 30 mph, otherwise gearbox damage may result. If the car is to be towed over long distances, or if the transmission is defective, the car must be towed with the rear wheels raised from the ground or propeller shaft disconnected.

### **Warning**

To prevent dangerous over-revving do not exceed the prescribed shifting speeds.

### **Stopping**

To stop the car release the accelerator pedal and apply the brakes.

No further action is needed for short stops, as first gear will be automatically re-engaged when moving off again. On upgrades, hold the car exclusively by pressing the brake pedal.

For long stops, move the selector lever to **hi** and apply the handbrake.

When leaving the car unattended shift the selector lever to P after coming to rest. Thus, the transmission will be locked.

## WHEEL CHANGING

If possible, place the car on level ground and lock rear wheels by the hand brake.

Release strap B and take out jack A and spare wheel C in trunk.

The jack is completed by hand lever D and extension E,

Extension E has two drives: a hex. shank for the jack hand lever and a hex. socket to manipulate both the jack and wheel bolts.

### To Remove the Wheel

- Slacken about one turn the four wheel fixing bolts using extension E and lever D.
- Place the jack under the car at the bracket nearest the wheel to be removed.
- Fit extension E to jack shank, and turn handwheel F until the jack contacts the lift bracket under floor.
- Make sure the ground is sufficiently hard (that is, jack base does not sink during the lift action).



- Fit the hand lever to extension E and actuate the lever to and fro until the wheel is clear of the ground.
- Back out completely the bolts and remove trim and wheel.
- Keep the bolts in a clean place to prevent the threads from getting fouled with dirt, a frequent cause of difficulties at reassembly.



## *To Fit the Wheel*

- Fit the spare wheel seeing that the location dowel fits into the location hole in wheel disk.
- Refit trim and refit and tighten uniformly the wheel fixing bolts in criss-cross sequence.



- Remove the jack hand lever and actuate handwheel F of extension E and lower the car.
- Fully tighten the wheel bolts in criss-cross sequence.
- Check that the newly fitted tire is inflated to the correct pressure.

When repositioning the jack in the trunk make sure extension E is properly housed and Jack, bag and hand lever D are correctly fastened by strap B.

## **JACKING UP AND TOWING**

When either the front or rear end of car must be raised with a garage jack, it is necessary to fit jack head under front suspension cross rail, interposing a suitably thick (abt. 3 cm - 1'A in.) wooden block, or rear axle bulge.

If car needs towing with a rope this must be attached to the specially provided front brackets.



34975





# MAINTENANCE

This section includes all periodical maintenance operations essential for continued effectiveness of the car.

The lubrication, cleaning, inspection and adjustment operations recommended in relation to given mileages are listed on a General Maintenance Schedule. Reference is made to the pages where each operation is described.

The Owners Warranty and Service Book contains a free service coupon. This service should be performed at 1 500 miles.

Failures, other than those resulting from defects in material or workmanship, which arise solely as a result of owner abuse and/or lack of proper maintenance are not covered by warranty.

Particular stress is laid on the importance of reporting to a FIAT Dealer for all the maintenance operations so marked :



For oil grades not mentioned here, see the Fill-up Data Table.

## EMISSION CONTROL SYSTEMS

The maintenance operations necessary to ensure the proper functioning of the vehicle emission control systems are printed in red for immediate identification both in the General Maintenance Schedule and in the paragraphs of this section.

The engine tuneup and adjustment specifications are also listed on the E.P.A. and California Regulations Conformity Tag, located in the engine compartment (see page 3).

For oil these operations it is also recommended to refer to the instructions specified in the Owners Warranty and Service Book,



































## NOTICE

Besides the routine maintenance operations listed in the Schedule, this section describes other operations which must be performed only in special cases of defective operation of mechanical units.

# MAINTENANCE

## GENERAL MAINTENANCE SCHEDULE

  We recommend that all operations so marked be entrusted to the Fiat service network

OPERATIONS	See page	Every 15 000 miles	Every 30 000 miles	Every 45 000 miles
 Valve clearance: <i>Check and adjust if necessary</i>	26			
 Air cleaner: <i>Renew filtering element</i>	27	• *		
 Spark plugs : <i>Changs.</i>	27		0	
 Alternator and water pump drive belt; <i>Check tension and state of wear; Adjust and/or renew as necessary</i>	28	o •	o	
 Oxygen sensor (Lambda probe): <i>Renew.</i>	32		o	
 Brakes; <i>Check state of wear of seals, lines and check hand brake efficiency, renew or adjust as necessary.</i>	38			
 Transmission (manual and automatic) and differential: <i>Change oil.</i>	39			
 Clutch: <i>Check pedal height and adjust if necessary.</i>	39			
 Suspensions, steering and drive line: <i>Check components.</i>	41	• 		
 Wheel bearings: <i>Check lubrication</i>	41			
 Body: <i>Lubricate door locks and hinges.</i>	43			

<sup>1</sup> These operations are not obligatory but only recommended when the car is used frequently in abnormal traffic conditions or on sandy and dusty roads.

# SPECIAL MAINTENANCE

## OPERATIONS

	See page	Every 500 miles (or weekly)	Every 3 000 miles	Every 7 500 miles
Engine oil - <i>Check level</i> . . . . .	26	0		
■ Engine oil and filter; <i>Change</i> . . . . .	26			
Cooling system : <i>Check cool/ant level</i> . . . . .	37	●		●
Brakes: <i>Check brake pads and front discs</i> . . . . .	38			●
Automatic transmission (where fitted): <i>Check oil level</i> . . . . .	40		●	
Tires: <i>Check pressure</i> . . . . .	41	●		
Battery: <i>Check electrolyte level, terminals and clamps</i> . . . . .	44		●	

## Lubricant Designations

FIAT	INTERNATIONAL	FIAT	INTERNATIONAL
VS+	Single-grade low-ash content detergent oils - API Service SE, to MIL-L.46152 and above :the CCMC European Sequence	G/A	A.T.F. - DEXRON II Type for automatic transmission
		W90/M	SAE 30 W/90 EP Oil to MIL-L-2105 B
ZC90	SAE SOW/90 Oil with anti-wear additives, for manual transmission	Jotai	Lithium-base Grease N.L.C.I. Mo. 1
		MR 3	Lithium-base Grease N.L.G.I. No. 3

# ENGINE

## Engine Oil

**Every 500 miles or weekly** - With engine cold, check oil level which must always be between the **Min** and **Max** marks on dipstick, and top up if required.

**Every 7 500 miles or every six months at most** - Replace oil with engine well warmed up.



Drain all used oil through plug B. Oil should of course be changed also in relation to the grade used and outdoor temperature (Singlegrade or Multigrade) as shown in the Fill-up Data Table,

## Engine Oil Filter

**Every 7 500 miles or at every engine oil renewal** - Unscrew filter A from its support on crankcase, and replace.



Before fitting a new filter on the support, wet its seal with engine oil. Screw on the filler: once the seal contacts the support, tighten 3/4 turn more.

## Tappet Clearance

**Every 15 000 miles** or whenever valve operation becomes noisy. Check clearance between tappets and cams. Specified clearance, with cold engine, is .41 to .49 mm (.016 to .019 in) for intake and .46 to .54 mm (.018 to .021 in) for exhaust valves.



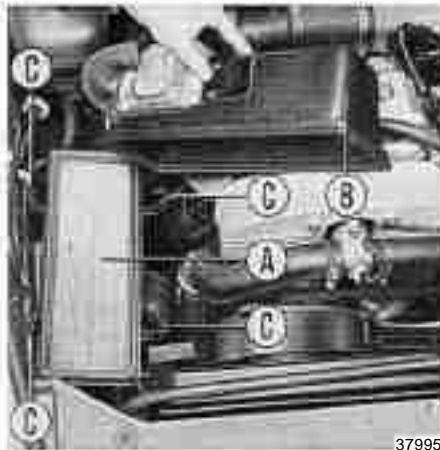

37995



## Spark Plugs

Every **30 000 miles (\*)**: Change spark plugs. To disassemble spark plugs, withdraw terminals A and back off using a suitable wrench.

New spark plugs must be of the type specified (see page 62); if their thermal rating is incorrect engine malfunction and/or failure may occur.

(\*) It is recommended that air cleaner and spark plugs be replaced every 15 000 miles if the vehicle is frequently driven in heavy traffic conditions or sandy or dusty areas.



## Air Cleaner

Every **30 000 miles (\*)**: Change filtering element. To gain access to filtering element A undo fasteners C using a screwdriver and remove cover B.

Change the filtering element, refit cover and secure with fasteners C.

Reinstall fasteners by pressing on curved section.



## Alternator and Water Pump Drive Belt

Every 30 000 miles (\*); Check belt for wear and if necessary renew, Also check belt tension and adjust if necessary,

Belt sag should be 1 to 1.5 cm (1/3 to 1/2 in.) when firm thumb pressure is applied. To adjust tension of belt

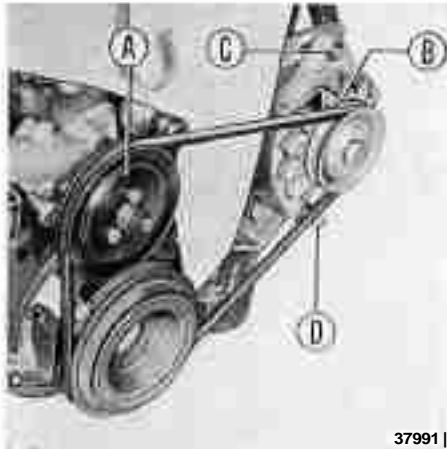

driving water pump A and alternator B, slacken nuts C and D and move alternator outwards and then retighten the nuts.

Do not exceed the tension since this would result in abnormal stress on the bearings.

(\*) It is recommended that [hese operations be carried out every 15,000 miles if the vehicle is frequently driven in heavy traffic conditions or in sandy and dusty areas.

## Ignition Timing

Spark advance is set in the factory and no further adjustment is required during the life of the vehicle.

Ignition timing must be checked only if the ignition distributor is removed. To adjust proceed as follows:

- For vehicles fitted with manual transmission, engage top gear and move vehicle until cylinder no. 1 is in compression phase and the mark on the crankshaft pulley is aligned with the fixed timing mark A indicating 10° B.T.D.C.

### Ignition timing:

A = 10° (Adv.); B = 5° (Adv.); C = 0° (TDC)

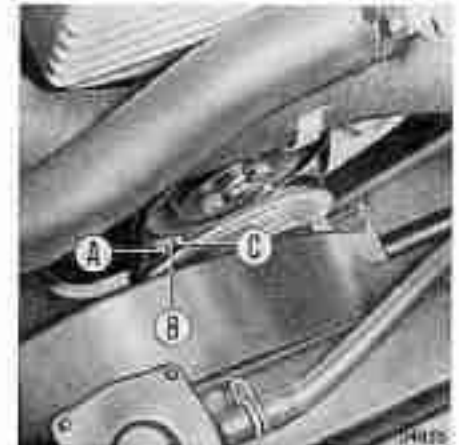

For vehicles fitted with automatic transmission use a suitable wrench to adjust the nut D securing crankshaft pulley until above conditions are obtained.

- Remove distributor cap and turn shaft manually until rotor is positioned against contact for firing of cylinder no. 1.

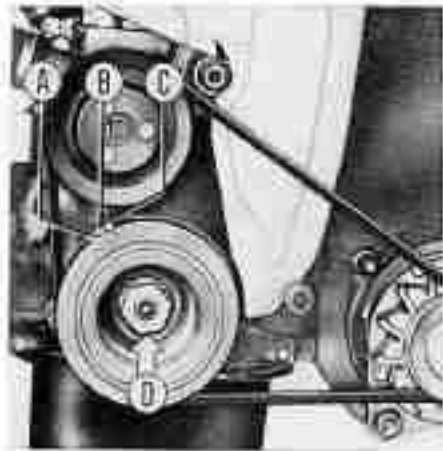

38113

Without moving distributor shaft, insert distributor<sup>1</sup> in its seat and secure. Connect leads going to coil, install cap and check that the leads are correctly connected to spark plugs,

Connect the rev counter and the stroboscopic lamp to the engine using spark plug lead for cylinder no. 1.

- Start engine and check ignition timing with the stroboscopic lamp. Ignition timing should be 10" B.T.D.C. at 800 to 850 rpm for vehicles with manual transmission and 10" B.T.D.C. at 700 to 750 rpm for vehicles with automatic transmission,

- If distributor calibration is not correct, slacken and rotate manually until correct calibration is obtained, then tighten it.

If distributor removal is not required, proceed from this point.

## **EMISSION CONTROL SYSTEMS**

Vehicle emissions are controlled by various devices that make up the crankcase emission control system, the exhaust emission control system and the fuel evaporative emission control system.

Any modification of the emission control systems is subject to federal laws and regulations and may incur penalties.

## **Crankcase Emission Control System**

This is a closed system designed to prevent any emission of blow-by gases and oil vapours into the atmosphere.

These gases and vapours are piped to an orifice downstream of the throttle and are then drawn into the engine in any rpm condition.

1. Emission feedback port
2. Throttle valve
3. Flame trap
4. Intake manifold
5. Sump-to-air cleaner line
6. Cyclone liquid/vapor separator
7. Oil drain line into sump

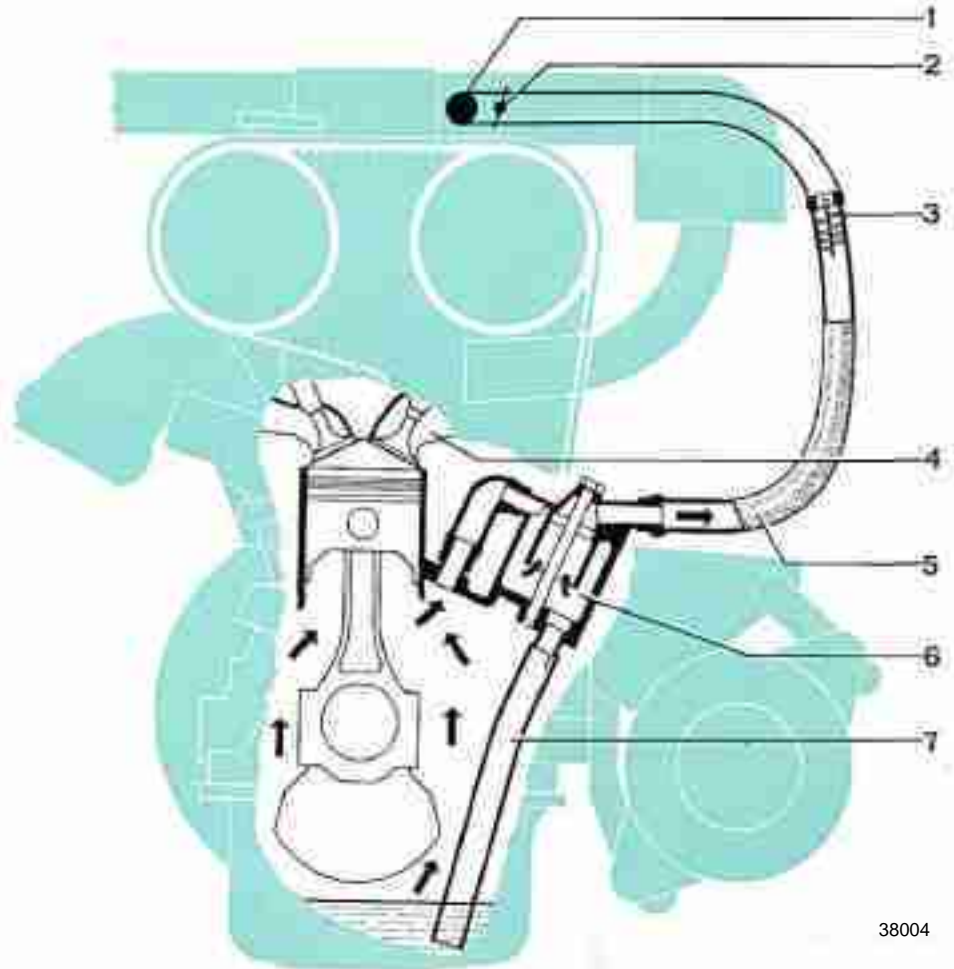

38004



## Fuel Evaporative Emission Control System

The fuel evaporative emission control system is designed to prevent air pollution caused by evaporative losses from the fuel system.

This is accomplished by a proper system which prevents the release into the atmosphere of fuel vapors from the fuel tank.

The fuel vapors from the fuel tank flow into the activated charcoal carbon canister where they are absorbed and stored when the engine is not operating.

When the engine is running, the fuel vapors retained in carbon canister are purged through a line which conveys them to intake manifold.

The system consists essentially of:

- Sealed filler cap.
- Limited-filling tank,
- Vapor-liquid separator.
- Two-way valve.
- Vapor vent line.
- Carbon canister.
- Purge line.

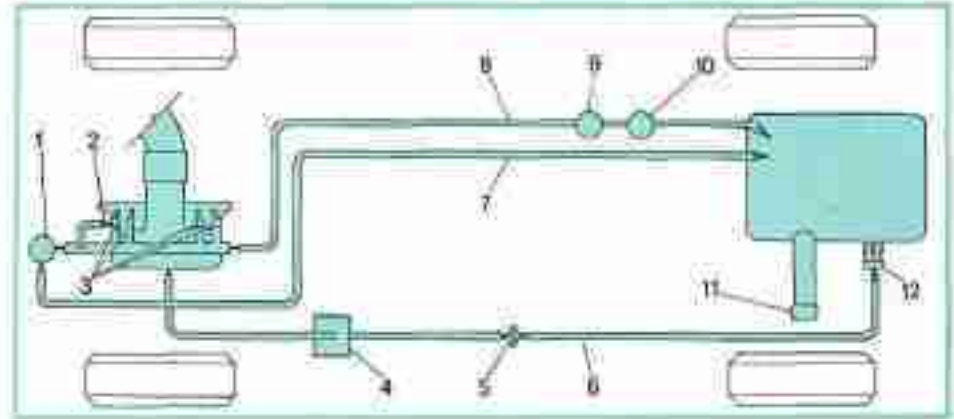

39069

1. Fuel pressure regulator - 2. Cold start solenoid injector - 3. Solenoid injectors -
4. Activated carbon canister - 5. Two-way valve - 6. Fuel tank vapor vent line - 7. Fuel return line - 8. Fuel delivery line - 9. Fuel filter - 10. Electric fuel pump - 11. Sealed filler cap - 12. Vapor-liquid separator.

## ***Ftief Injection System***

### ***General***

This is an electronically controlled intermittent low pressure injection system.

The fuel is injected upstream of the intake valves by means of solenoid injectors supplied at constant pressure. Flow is controlled by means of variation in the opening time of the injectors.

The main factor controlling flow is the direct measurement of drawn air by a special sending unit which transmits the most important information for fuel metering to the electronic control unit.

The system is also provided with a certain number of measuring sensors which provide the electronic control unit with the information required to optimize the composition of the mixture in all engine operating conditions.

### ***Exhaust Gas Emission Control System***

For the control of exhaust gas emissions, the injection system is fitted with

an oxygen sensor (Lambda probe) which measures the oxygen content of the exhaust gases and transmits any adjustment of the air-fuel mixture to the control unit. It is thus possible with the aid of a catalytic converter fitted to the exhaust pipe, to reduce to a minimum the harmful residues contained in the exhaust gases.

### ***Oxygen Sensor {Lambda probe}***

Every 30,000 **miles**: Renew oxygen sensor. An indicator on the instrument panel lights up on completion of 30,000 miles (see page 7) signifying that the sensor must be replaced.

To renew sensor proceed as follows:

- Disconnect probe cable A.
- Back off probe B from its seat C on exhaust manifold.
- Fit new probe lubricating threaded part with anti-seize, anti-rust grease.
- Reconnect cable A.
- Press button to zero indicator.



# ELECTRONIC FUEL INJECTION DIAGRAM

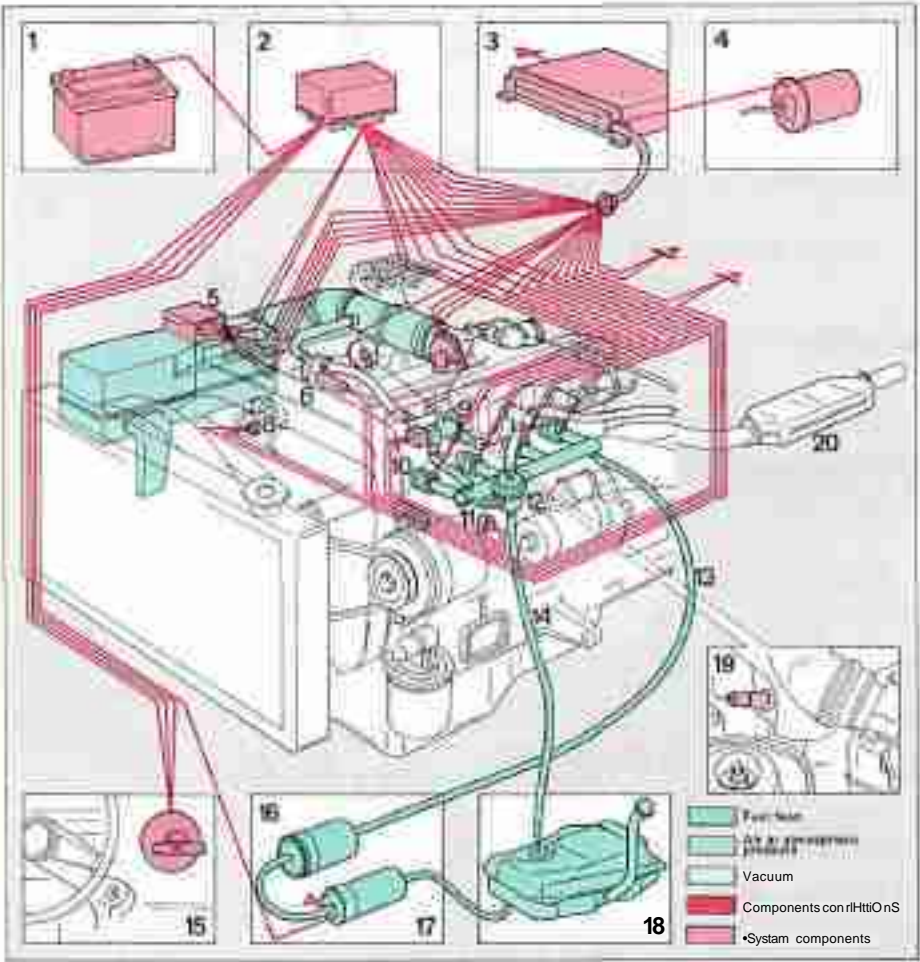

3800S

## 1. Battery

2. Relay set - Operates electronic control unit 3 and motor driven fuel pump 17.

## 3. Electronic control unit

Receives information about oil quantity, coolant temperature and temperature of cylinder head, position of throttle valve, starting phase as well as engine rpm and injection point.

it processes this information and transmits electric pulses to the solenoid injector.

It is connected with the individual components by means of a multiple connection plug and associated connecting cables.

## 4. Coil

In addition to its normal function, it transmits the number of engine rpm or the injection point to the control unit.

### 5. Air measuring instrument

This supplies information to electronic control unit of quantity of air drawn and activates fuel supply pump,

### 6. Supplementary air valve

Supplies extra air during engine heating stage, depending on temperature level.

### 7. Throttle switch

Signals idle and full load to electronic control unit.

### 8. Temperature sensor

Signals coolant temperature at the cylinder head outlet

### 9. Cold starting solenoid injector

During starting in low temperatures, injects extra fuel into intake line.

### 10. Solenoid injectors

Inject fuel in intake port of cylinders.

### 11. Delay thermal switch

This automatically controls injection of cold starting solenoid injector.

### 12. Fuel pressure regulator

Keeps fuel pressure constant in fuel lines.

### 13. Fuel delivery line

### 14. Excess fuel exhaust line

### 15. Ignition switch

### 16. Fuel filter

Is fitted on fuel supply line for fuel filtering.

### 17. Motor driven fuel supply pump

Delivers a constant supply of fuel to solenoid injector.

### 18. Fuel tank

### 19. Oxygen sensor (Lambda probe).

Measures the oxygen content of exhaust gases and transmits any adjustment of air-fuel mixture to control unit.

### 20. Catalytic converter

Reduces harmful residues contained in exhaust gases to a minimum.

**Note:** You are advised to take the following precautions:

- Never start the engine if the battery is not properly connected.
- Do not use charger with battery leads disconnected.
- Never disconnect battery leads with the engine running.
- When charging battery, disconnect clamps.
- If temperature is above 80° C (special body work) disconnect electronic control unit from vehicle.
- Never remove or insert control unit harness connector with ignition switched on.
- If car is to remain out of service for some time, add 10% of engine oil to the fuel tank.

## **Idling Speed**

Any adjustment to idling speed must be carried out with a warm engine and with gearshift lever in neutral position for mechanical versions and in D (drive) position for automatic versions.

The engine is warm when the radiator electric cooling fan has been activated at least twice.

To adjust idle the electric fan must be off.

To adjust, turn bypass screw A.



idling speed is  $550 \pm 50$  rpm for manual transmission and  $750 \pm 50$  rpm for automatic transmission.

## **Idle CO Setting**

The idle co setting is factory adjusted and sealed. No additional adjustment is required when tuning up engine during the useful life of the vehicle.

## **WARNING**

### **Fuel Refilling**

Strictly adhere to the label on instrument panel and on filler cap.

## **UNLEADED FUEL ONLY**

Leaded fuel will damage the catalytic converter beyond repair. Always refill at Service Stations which carry unleaded fuel (small pump nozzle).

# COOLING SYSTEM

## Coolant Circuit

**Every 500 miles or weekly** - Check the coolant level in system expansion tank, with cold engine: the level must always be abt. 7 cm (2 $\frac{1}{2}$  in) above the MIN mark on tank.

When engine is very hot the level might rise noticeably: this could also happen immediately after stopping the engine.

Should the coolant level drop below the tank MIN mark, top up by removing



expansion tank cap and pouring in coolant, seeing that its level is as specified.

**Warning:** Do not remove radiator or expansion tank caps on a hot engine to avoid possibly scorching your hands; wait until engine has cooled down. Do not top up a hot engine with cold water.

**Should more than 2 consecutive top-ups be required at short intervals, or after limited mileages (500 miles), the system needs checking. This applies also when water temperature gage pointer stays on the red sector (see page 6).**

To drain cooling system, move lever D to the left {see page 12}, open the cocks on radiator lower side and on cylinder block, and disconnect expansion tank hose.

To fill the system:

- Connect expansion tank hose, close radiator cock and remove plug A.
- Pour in water slowly through radiator filler port until water overflows, then refill the expansion tank.
- Refit radiator and expansion tank caps *and* plug A then run the engine so as to favor a thorough mixing of the fluid in the system.

- Stop the engine, slacken plug A, wait for a proper system bleeding and refit the plug.
- With engine cold check the level in expansion tank and, if nee. top up.

## Antifreeze Mixture

The cooling system is filled with an antifreeze mixture effective down to  $-35^{\circ}\text{C}$  ( $-32^{\circ}\text{F}$ ). In case of coolant change or topping-up **FIAT** recommends the use of a 50-50 mixture of water and **Parafllu 11** fluid (or equivalent), which allows the use of hard or chlorinated water and incorporates



oxidation, corrosion, foam and scale inhibiting properties and is effective down to — 35°C (—32° F). See Fill-up Data Table.

This mixture shall subsequently be replaced after **45 000 miles** or every **two years**, whichever occurs first thus reducing the need for any servicing action on the cooling system.

When this mixture is used, plain water may be added only in emergencies (sudden heavy coolant losses).



As soon as possible repair the fault and refill the system with the recommended coolant.

## **BRAKES**

Brake system with front and rear independent circuits.



If pedal free travel has become excessive, if braking unbalance on one wheel is appreciable or if pedal sponginess is felt with consequent reduced brake effectiveness, a complete inspection of the system is needed.

### **Fluid Reservoir**

The « Low Brake Fluid Level » indicator (see page 7), controlled by a float and switch assembly on brake fluid reservoir, warns the driver of a sudden drop in brake fluid.

- A - Front brake fluid section
- B - Rear brake fluid section



**Every 15 000 miles** - Top up brake fluid reservoir. Use exclusively DOT 3 MotorVehicle Brake Fluid (conforming to F.M.V.S.S. No. 116). Avoid using any other type of fluid which would damage the special rubber parts in the system.

### **Front Brakes**

**Every 7 500 miles** - Check that brake linings are not worn down to less than 1.5 mm (.06 in). Replace if required.

### **Lines and Fittings**

**Every 15 000 miles** - Check hoses and fittings for leakages and tightness.

### **Bleeding**



Bleeding is a delicate operation requiring the necessary know-how and should only be needed when air has entered either one or both brake circuits (line disconnection,

fluid drainage, etc.). This is indicated through pedal sponginess and reduced braking effectiveness.

### **Hand Brake**

Every **15 000 miles** or sooner if hand lever stroke is excessively long, **pull up the lever three notches and adjust through the appropriate tensioner** (see figure below).

**Then release the lever and check that the wheels are not locked.**



## **POWER TRAIN**

### **Clutch**

The clutch is mechanically controlled, with automatic wear take up and no pedal free travel.

### **Every 15 000 miles**



Check pedal height and adjust if necessary.

After repeated adjustments, check clutch facings for excessive wear: replace if required.

### **Manual Transmission OH**

### **Every 30 000 miles**

Renew oil. Let drip thoroughly from plug B before refilling. The correct level is up to the opening of filter plug A.

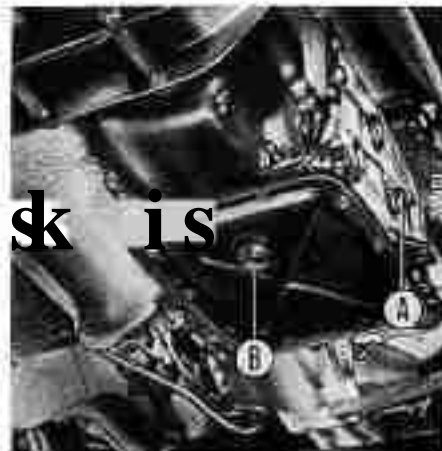



## Automatic Transmission

(Where fitted)



If defective transmission operation is detected contact your nearest FIAT Dealer.

### Every 3 000 miles

Check the fluid level. Correct level is between the MIN and MAX marks on dipstick A.

Before checking the fluid level drive about 6 miles to reach normal operating temperature, stop the car on level ground but keep the engine

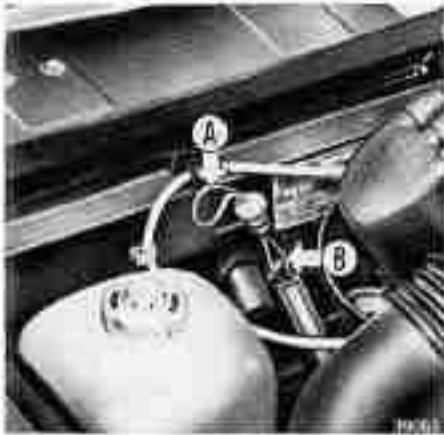

running at idling speed, and move the gear selector lever to P or N.

If necessary, top up to the MAX mark through filler B using **Fiat GI/A** or equivalent grade of automatic transmission fluid. Do not overfill.

The utmost care should be taken to ensure that both the containers and the funnel used for topping up are absolutely clean.

Following emergency topping-up after a sudden leak, owners are recommended to contact the nearest FIAT Dealer for a general inspection of the transmission.



**Every 30 000 miles or two years** - Renew the fluid with a warm transmission. If the fluid is found to be heavily soiled, also renew the filter in the valve assembly, together with the associated seal.

To renew the fluid remove plug A. To renew the filter remove sump B.

### Axle Oil

#### Every 30 000 miles

Renew oil after thorough draining through plug B. The correct level is up to the opening of filler plug A.



## SUSPENSIONS AND STEERING

### Front Suspension [Steering Articulation Boots and Caps

Every 15 000 miles or whenever underbody inspections are carried out, check the condition of ball joint rubber caps and steering gear rack rubber boots.



If they are damaged, replace. The new caps should be packed with **grassofiat MR 3** prior to their installation.

At the same time inspect ball joints for excessive play. If evidence of looseness exists, replace the ball joint.

Proper joint maintenance is essential for car safety.

### Front and Rear Suspensions



Check rubber mounts for proper efficiency.

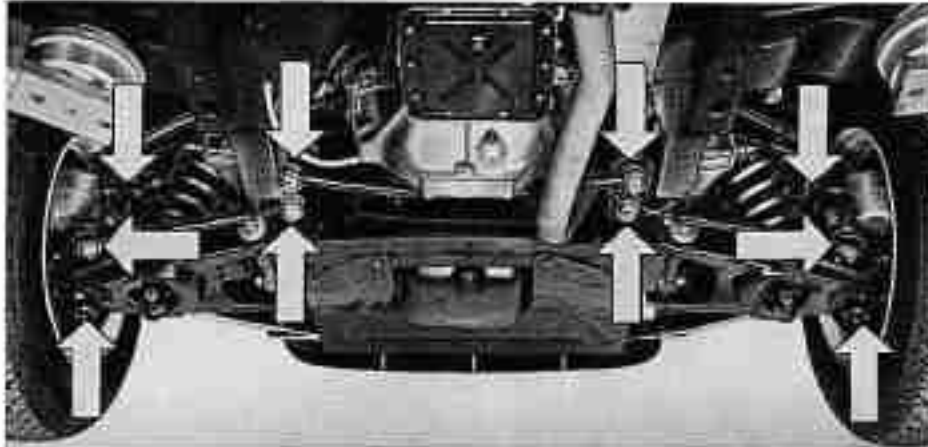

### Front Wheel Bearings

Every 30 000 miles - Check bearings for play and adequate lubrication. Adjust and lubricate with **grassofiat MR 3**, if needed.

## TIRES

Every 500 miles or weekly - Check pressure with a gage not forgetting the spare wheel (see page 56 for pressures).

Make sure pressure is exactly the same in each pair of tires. In hot climates, do not reduce pressure as this would only increase tire temperature.

## MISCELLANEA

### Windshield Washer

Every 7 500 miles approximately Check level in the bottle located in left headlamp compartment.

In case of incorrect jet aiming: Clean the jet squirt hole accurately (by a needle).

Check also electric pump terminals.

To re-aim jets: Turn the complete body with a screwdriver and then the lateral pin so as to direct the water squirt to top of wiper sweep arc.

### **Windshield Wiper**

#### **Every 7 500 miles approximately**

Check for proper efficiency.

To remove a wiper blade, tilt out the arm, free blade mount A from its lock dowel B on arm and extract the blade upwards.

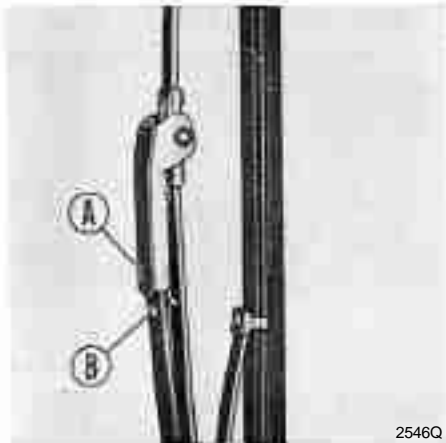

2546Q

**Note** - When adjusting wiper arms position on windshield ensure that the distance from windshield base to wiper arm fulcrum is:

driver's side = 55 to 75 mm

passenger's side = 70 to 90 mm



## **BODY**

### **Every 15 000 miles**

Lubricate the following items as required using the recommended products:

Door lock cylinders with **graphite powder**.

Door locks through the specially provided hole (near lock) blanked by a plastic plug, door hinges and limiter, and front seat reclinable backrest control with **engine oil**. Window venti-pane joints and hinges with **glycerine** (2-door version).

Trunk lids and engine hood catches and hinges with **petroleum jelly**. Seat guide rails with **grassofiat Jotai**.

### **Tool Kit**

The tool box contains:

- Wrench, socket, spark plugs
- Wrench, double end, 8x10 mm
- Wrench, double end, 13x17 mm
- Screwdriver, double-tipped
- Punch, straight
- Wrench, wheel bolts

The jack is stored in trunk, on right-hand side.

## ***Exterior Body Care***

Wash the bodywork frequently with cold or lukewarm water. Sponge down using a good quality car shampoo - **Deterlux** or equivalent. Never use household soap or detergent, otherwise the paintwork may be adversely affected.

If a hose is used avoid directing it at full force against the body. Rinse thoroughly and dry off with a clean chamois leather.

Do not wash your car in the sunshine, especially in hot climates or when the hood is still hot.

When cleaning the windshield raise the wipers clear, and do not force them sideways.

An occasional light polish with an approved silicone car polish will give

the paintwork extra protection. Also remove any stain promptly.

Grease and tar should be removed using a clean and soft kerosene- or gasoline-moistened cloth. Subsequently, apply a fresh coat of polish.

To clean the windows use a good quality spray type window polish - DP 1 or equivalent - and wipe dry with water-absorbing paper.

Chromium-plate and any other bright decorative metal parts are best cleaned with either cold or tepid water, or any reputable make of car chrome cleaner.

To preserve the rubber seals of doors, hood and trunks use silicone grease. This will also prevent squeaking, particularly during the cold season.

## ***Interior Body Care***

Dust the interior, preferably using a vacuum cleaner.

To remove grease spots from cloth lining use a good brand of stain remover (petroleum ether or light gasoline) apply talc liberally, allow to soak and brush off.

To remove dirt from the seats or any other imitation leather-lined part use a damp sponge and a neutral or bland soap. Subsequently, rinse with a clean damp sponge and dry off using chamois leather.

Textile fiber mats should be cleaned using a moistened cloth with good quality detergent.

Rubber mats or floor lining should be washed with a damp sponge and neutral detergent or water and soap.

## ***PROLONGED INACTIVITY***

If the car is to remain inactive over long periods it is advisable to carry out the following operations:

- Store the car in a covered, dry and ventilated place.
- Ensure that the handbrake is released.
- Do not empty the cooling system: in cold climates, if necessary, replace the coolant with a reliable high grade anti-freeze mixture.
- Check the tire inflation pressures periodically.
- Re-charge the battery about every six weeks.
- Switch off any electrical loads and remove the ignition key.
- Protect the finish with a coat of good silicone wax.
- Coat all bright metal parts with a reputable make of car chrome preservative.

- Remove the wiper blades to prevent the rubber from distorting.
- Protect the car using a non-plastics car cover.

If the car is to be left in the open spray the underside and the entire engine compartment with an approved engine preservative, **PROT V** or equivalent. Do not spray a hot engine.

Before starting a sprayed engine open the hood and wait for at least ten minutes.

Prior to using the car following a prolonged period of inactivity perform the following operations:

- Remove the chrome preservative from all bright metal parts.
- Wash the car.
- Renew the engine oil.
- Recharge the battery,
- Refit the wiper blades.
- Check the tire inflation pressures (including that of the spare wheel).

## ***ELECTRICAL SYSTEM***

### ***Battery***

Located in trunk.

**Every 3 000 miles or monthly** - With battery at rest and cold, check the electrolyte level.

**In hot climates**, check the level more often.

When liquid additions are needed, add distilled water (battery cold), never electrolyte fluid (which contains sulphuric acid) as only water evaporates from the battery in service, **never** the acid.



**WARNING** - The battery contains sulphuric acid. Avoid contact with skin, eyes or clothing.

*External antidote:* Flush with water.

*Internal antidote:* Drink large quantities of water or milk.

Follow with milk of magnesia, beaten egg or veg. oil.

Call physician immediately.

*Eyes:* Flush with water for 15 minutes and get prompt medical attention.

Batteries produce explosive gases. Keep sparks, flame, cigarettes away.

Ventilate when charging or using in enclosed space.

Always shield eyes when working near batteries.

Keep out of reach of children.

## Every 3 000 miles

Check posts and clamps for tightness and cleanliness.

Except in particular service conditions the battery does not require any periodical recharge.

As your car is fitted with electronic devices never run the engine - even for a very short while - with battery disconnected from the alternator or wrongly connected (positive ground) otherwise serious damage will result.



## Fuses

Nine 8-Amp. and three 16-Amp. fuses in a box under dash, driver's side, and two 8-Amp. and 16-Amp. fuses in separate holders.

Before replacing a blown fuse trace the cause and remedy accordingly.

## Unprotected Circuits

Alternator, starting and starter relay, ignition high beams relay coil, battery charge indicator, radio set (where fitted), electronic fuel injection system.



## *Protected Circuits*

### A (8 Amps)

Turn signal lamps and indicator  
Stop lamps  
OH pressure gage and insufficient pressure Indicator  
Engine coolant temperature gage  
Fuel gage, with reserve indicator  
Engine tachometer  
Low brake fluid level and hand brake ON indicator  
Back-up lamps  
Fast idle electrovalve  
Fasten belts indicator and relay for buzzer  
Delay circuit for fasten seat belts indicator and buzzer  
Selected gear indicator light (autom. transmission)  
30 000 miles pick-up and indicator

### B (8 Amps)

Windshield wiper motor  
Heater fan motor  
Windshield washer pump  
Windshield wiper sweep rate rheostat

### C (8 Amps)

Left headlight high beams  
High beam indicator

### D (8 Amps)

Right headlight high beams

### E (8 Amps)

Left headlight low beam

### F (8 Amps)

Right headlight low beam

### G (8 Amps)

Front right parking lamp  
Rear left tail lamp  
Front right/rear left side marker lamps  
License plate lamp (right)

### H (8 Amps)

Front left parking lamp  
Parking and tail lamps indicator  
Rear right tail lamp  
Front left/rear right side marker lamps  
License plate lamp (left)  
Cigar lighter housing indicator  
Trunk light  
Instrument cluster light  
Ideogram illumination optical fibers light source  
Vehicular hazard warning signal switch light

### I (8 Amps)

Quartz crystal clock  
Courtesy light  
Hazard warning flasher and indicator  
Inspection lamp receptacle  
Remove key and fasten belts buzzer

### L (16 Amps)

Horns  
Engine fan motor

### WI (16 Amps)

Power window motor {Left-if fitted}

### N (16 Amps)

Power window motor (Right - if fitted)

### **In separate holder (8 Amps)**

Cigar lighter

### **In separate holder (16 Amps)**

Fuel pump  
Supplementary air valve

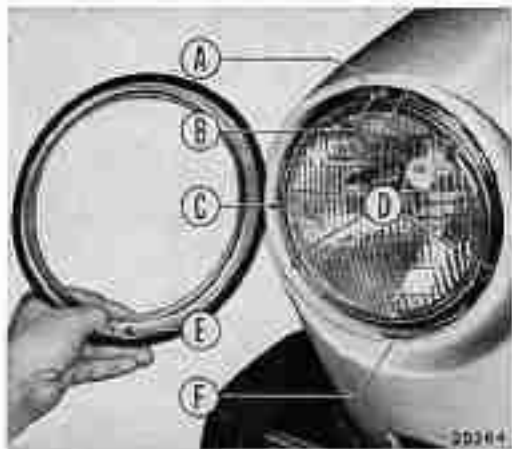

## Lights

### Headlights

#### Alignment

For aiming the headlights, screw 6 (vertically) and C (horizontally) are readily accessible after removing retaining ring G.

#### Removal

Turn off screw E and remove retaining ring 6. Slacken 4 screws D and, by turning counter-clockwise remove headlight unit L. Then pull off terminal socket I.

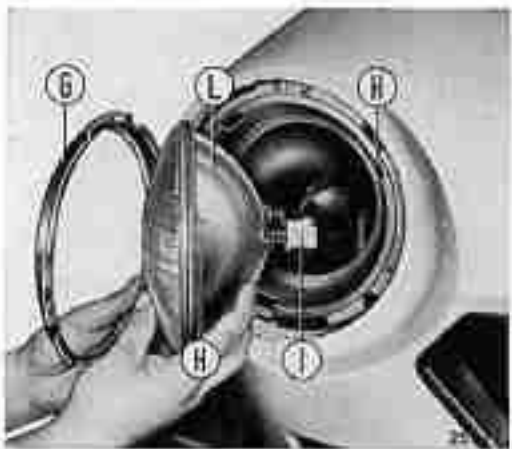

**Caution:** Replace blown bulbs exclusively with bulbs of the same type and wattage. Weaker bulbs will diminish visibility whereas stronger bulbs will draw a greater amount of current and overwork the alternator, resulting in progressive battery discharge. For bulb specifications see page 63.

### Installation

Center headlight unit L on body by aligning locating dowel H with its seat. Turn the unit clockwise and tighten screws D. Refit retaining ring G by tightening screw E in hole F.

### Front Parking and Turn Signal Lamps

- A Lens mounting screws
- B Lens
- C Bayonet-coupled bulb, double filament
- D Positioning tabs

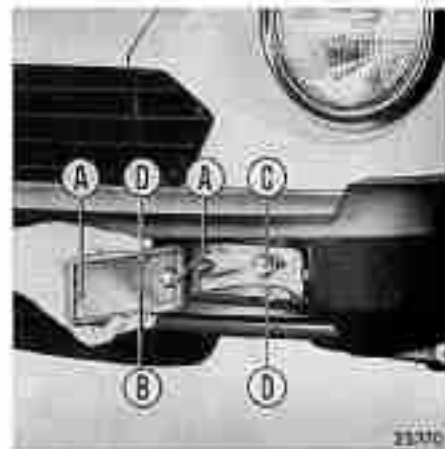



### **Rear Turn Signal, Stop and Back-up Lamps**

The bulbs are accessible from inside trunk after removing panel A.

To remove the panel free it from the arrowed lugs.

The bulbs are of the bayonet type.

- B** Turn signal light
- C** Stop light
- D** Tail light
- E** Back up light

### **Side Marker Lamps**

The rear bulb holders are accessible from inside the trunk.

To remove the bulb, disconnect bulb holder A from seat B by turning counterclockwise.

Bulb C is of the plug-in type.

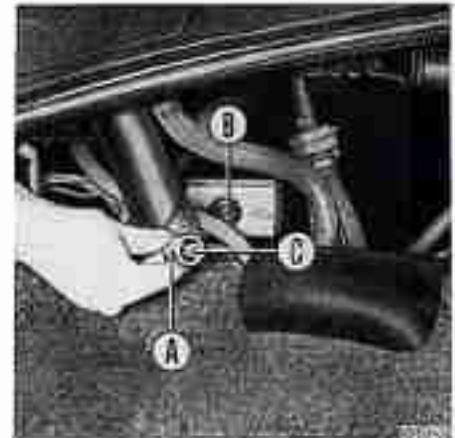
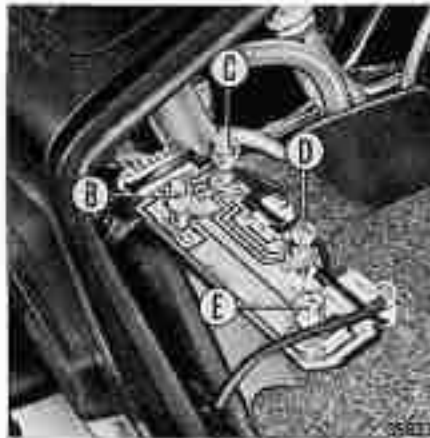
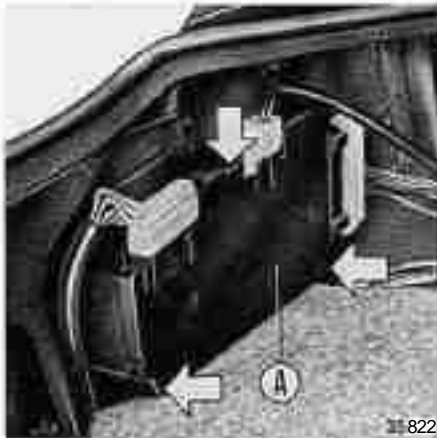

Front bulbs are accessible from inside fenders.

To remove or refit follow the procedure given for the rear bulbs.

### **Courtesy Lamp**

- A Spring plates (two) unit mounting
- B Switch
- C Bulb, pressure mounted
- D Lens and body unit

### **License Plate Lamps**

To withdraw bulb holder remove retaining nuts from inside the trunk.

- A Body retaining screws
- B Body and lens
- C Bulb holder
- D Bayonet-coupled bulb
- E Gasket

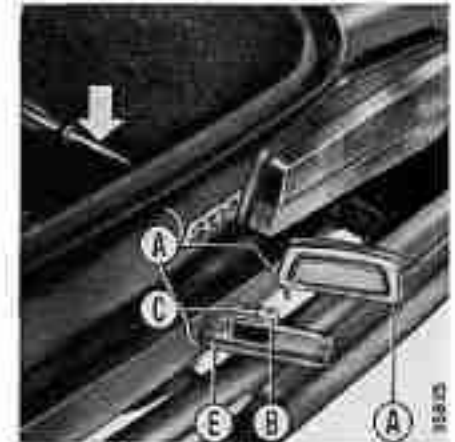

***Advice  
for bodywork  
maintenance***

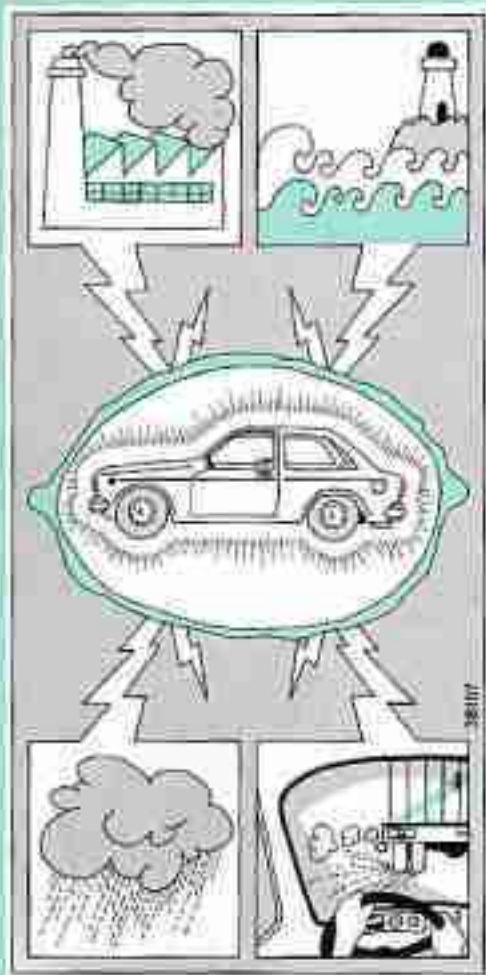

## Protection from Atmospheric Agents

FIAT has introduced a series of measures to protect the automobile from the various factors that can cause damage and corrosion.

Briefly summarized, these factors are:

- Atmospheric pollution (urban environments and industrial zones)
- Airborne salts (marine areas, particularly those with warm and humid climates)
- Seasonal and ambient humidity conditions (use of salt on roads during the winter).

The paintwork and body shell underside can be subjected not only to the chemical action caused by the factors mentioned above, but also to the abrasive action of airborne dust and sand, mud, and loose gravel thrown up by passing cars as well as the damaging action of salt spread on the roads in winter.

FIAT's answer to this problem can be summarized as follows:

- Corrosion and abrasion resistant paints and painting systems.
- Widespread use of pre-treated and highly corrosion resistant sheet metal.
- Spraying of the underside of the floor plan, engine compartment, wheel boxes, and the various box sections with highly adhesive protective waxes.
- Adequate covering or protective spraying with setting plastic of such particularly exposed parts as the door sill panels, wing interiors, borders, and so on.
- Use of enamels with greater resistance to polluted and industrial atmospheres.

Obviously the factors we have described act in different ways in different cases, according to the environmental conditions and the use of the car. Equally obvious is the fact that the owner who cares about his car and maintains it properly can make it last longer. We would like to list a few useful hints and pieces of advice which, though obvious, often pass unobserved for that very reason. The FIAT Service Network will be happy to supply more details on request.

### Body Paintwork

Needless to say, the paintwork does not serve only an aesthetic function, but also covers and protects the metal on which it is deposited.

Therefore, any abrasion or deep scratches that expose the sheet metal should be retouched immediately to avoid pitting by rust.

This retouching should always be done with original products (see paint identification plate).

Washing the car is the greater part of normal paint maintenance.

The frequency of washing depends not only on the frequency of use, but also on the nature of the car's surroundings: washing should be more frequent in more polluted areas, or if the car is often parked under trees which produce harmful resins.

A correct wash should be done as follows: First the car should be wet down with water at low pressure and sponged down with a light (2 - 4%) detergent solution. Rinse the sponge frequently. Rinse the car with a spray of water to carry away the loosened dirt, then dry with an air jet or chamois leather.

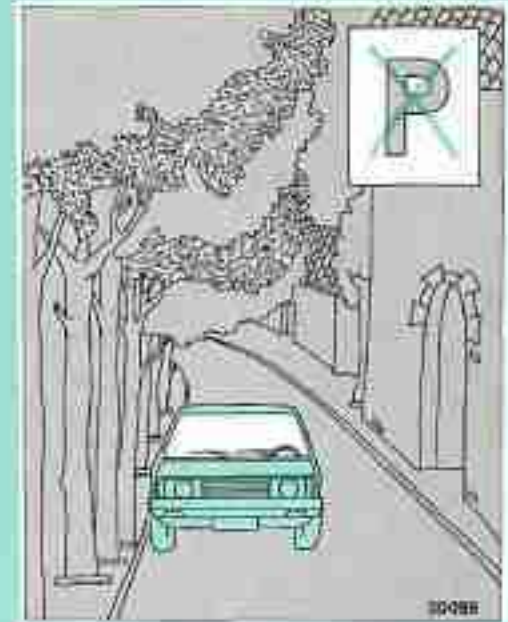



Be particularly careful to dry the less visible areas, such as the door frames, hood and headlight housings, where standing water can collect more easily. Similarly, avoid putting the car in a closed space immediately after washing, so that air circulation can help evaporate any trapped water.

Do not wash the car after it has been parked in the sun, or if the hood is still hot, as this could adversely affect the brilliancy of the paint.

The occasional use of a silicone car wax will give the paintwork extra protection and keep it shiny. If the paintwork becomes cloudy due to smog accumulation, a slightly abrasive light wax polish can be used.

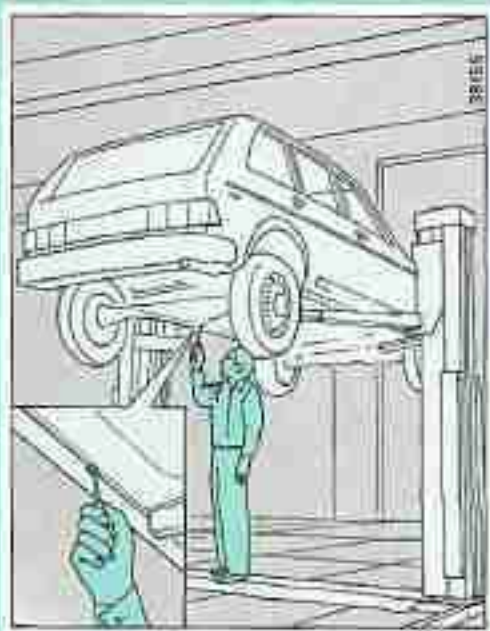

### Body Underside

The less accessible areas of the underside and frame box sections have already been treated to ensure longer duration.

Regular check-ups should be made on the car. The aim of these is to survey the soundness of the body and mechanical components, as well as to repair any damage. Particular attention should be paid during check-ups to the drainage holes in the underbody box frames and door frame undersides. These holes serve to drain any water that may accumulate while driving the car in the rain or while washing it, and so should be kept clear.

In harsh environmental conditions, periodic supplementary protective treatments to the box sections and door interiors are recommended.

These treatments must be done with special products and techniques, and so should be left to experts. It should be done at least every two years, and, in more severe cases, annually, preferably at the beginning of winter.

### Car Interior

The maintenance of the passenger compartment is no less important than that of the exterior. The same care should be devoted to it.

Check to see that there is no standing water under the mats or floor lining, as this could cause rusting. Dust the seats and cloth parts with a brush or vacuum cleaner.

To remove grease spots use petroleum ether or light gasoline, apply talc and brush off.

To clean seats in imitation leather, use a damp sponge and a neutral or bland soap. Rinse several times with a clean damp sponge.

While cleaning perforated seat covers, be particularly careful that water does not seep through the holes to the padding.

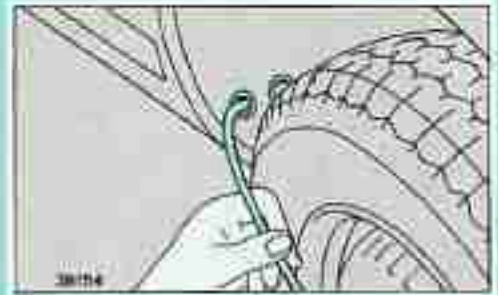



## Windows

To ensure perfect visibility, windows should be cleaned with a good quality glass cleaner and then wiped dry. Always use a clean cloth to avoid scratching the glass.

To clean the inside of the windshield, where more obstinate grease deposits are to be found, use sulphur ether as a solvent.

The inside of the rear window can be cleaned in the same way, but particular care should be used to avoid damaging the demister wires embedded in the glass.



## Engine Compartment

The engine compartment should be well washed at the end of every winter to avoid damage caused by salt on the roads.

## Chromium Trim

Chromium parts should be coated occasionally with car chrome preservative to protect them from atmospheric agents.



## Cleaning Plastic Parts

Exterior plastic parts should be washed in the same way as the car itself. If traces of dirt remain, use special plastic cleaners, following the manufacturer's instructions. Interior plastic parts can be cleaned in the same way. Do not use paint cleaners.

## Cleaning the Convertible Top

To properly clean the convertible top, use the following procedure:

- Do not perform cleaning procedure in direct sunlight.
- Thoroughly wet down the entire vehicle with water.
- Keep vehicle wet through entire cleaning operation.

**Caution:** Make sure soap and cleansers do not run onto a dry body finish since it may cause streaks or stains if allowed to dry.

- Apply a mild foaming cleanser to the entire top.
- Use a Lestoil and Fantastic mixture with clean warm water in a 2 to 1 ratio.

For example:

- 1 pint Lestoil
- Vs pint Fantastic
- $\frac{1}{2}$  gallon clean water



- Scrub the top with a small medium-soft bristle brush adding water, as necessary, until the cleanser forms a soapy consistency.
- Remove the first accumulated dirt from the top with a cloth (towel) or sponge before it can be rubbed back into the fabric top.
- Apply a fresh mixture of cleanser and clean water to top. Scrub top with brush until the top is clean.
- Thoroughly rinse the top with clean water to remove all traces of cleanser.

If any dirt spots are still on the top, apply Lestoil directly to the wet top, utilizing the same scrub brush and a final rinsing with clean water.

### Leaving **the** Car in the Garage

A car left in the garage is subject to damage by humidity, which is generally greater in a closed space than in the open air.

Parking the car in the garage while wet or covered with snow will increase humidity through slow evaporation. In such cases the car should be dried. Do not store large quantities of water in the garage. Make sure that the garage has windows or other openings to ensure adequate ventilation.

## Prolonged Inactivity

If the car is to remain inactive over long periods, It is advisable to carry out the following operations:

- Clean and protect the painted areas with silicone wax, Coat the bright metal parts with a standard chrome preservative.
- Store the car in a covered, dry and ventilated place.
- Ensure that the parking brake is released.
- Disconnect the battery terminals.
- Remove the wiper, blades and coat with talc.
- Open the door windows slightly.
- Protect the car using a non-plastic car cover. This should not be waterproof.
- Check the tire inflation pressure periodically.
- Check the battery charge every  $iy_2$  month. When necessary, use a slow 24 hr. charge.
- Do not empty the cooling system.

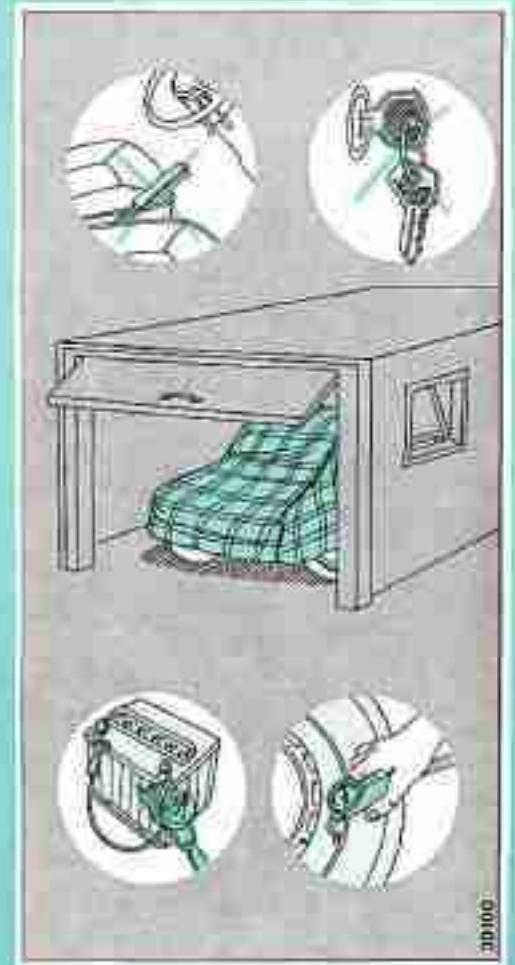



# SPECIFICATIONS

## ENGINE

Type	.132 C3.031
Number of cylinders, in line	4
Bore and Stroke	84x90 mm (3.31 x 3.54 in.)
Total piston displacement	1995 cc (121.74cu. in.)
Compression ratio	8.2 to 1
Maximum power (SAE net) at	102 HP 5500 rpm

## Valve Gear

O, H.V.

Twin O. H. camshafts driven by toothed timing belt with tensioner.

Intake	Opens: B.T.D.C.	5°
	Closes: A.B.D.C.	53°
Exhaust	Opens: B.B.D.C.	53°
	Closes: A.T.D.C.	53°

Tappet clearance adjustment, for valve timing .80 mm (.031 in.)

Final tappet operation clearance adjustment, **cold engine:**

Intake	.41 to .49 mm (.016 to .019 in.)
Exhaust	.46 to .54 mm (.018 to .021 in.)

## Lubrication System

Forced circulation by gear pump.

Pressure limiter valve on delivery circuit.

Full-flow cartridge oil filter.

## Fuel System

Electronically controlled fuel injection.

4 injectors, one per cylinder plus one auxiliary injector for cold starting, all supplied at constant pressure.

Gasoline flow governed by variation in opening time of injectors.

An air measuring instrument is used for flow variation.

Electric sensors optimise the mixture in all engine operating conditions, supplying information to the electronic control unit.

Air cleaner installed before air measuring instrument with paper cartridge.

## Cooling System

Radiator and translucent expansion tank.

Water circulated by centrifugal pump.

Thermostat with controlled by-pass on cylinder head water outlet duct.

Four-blade fan driven by electric motor controlled by thermostatic switch on radiator: cut-in temperature about 90° C.

## Ignition System

Firing order . . . . . 1-3-4-2

Basic ignition timing

— at 800 to 850 rpm (manual transmission), at 700 to 750 rpm (automatic transmission).

Automatic advance . . . . . 18° ± 2°

## Spark Plugs

Type: Champion RN9Y

Thread size: 14 x 1.25 mm

Gap: 0.7 to 0.8 mm (0.027 to 0.031 in)

## POWER TRAIN

### Clutch

Mechanically controlled, automatic wear take up no pedal free travel.

## Manual Transmission

Five forward speeds (all synchronized) and reverse.

Gear ratios to 1 :

1st	2nd	3rd	4th	5th	Reverse
3.667	2.100	1.361	1	.881	3.244

## Automatic Transmission

(Optional Extra)

G. M. hydraulic torque converter-gearbox unit.

Transmission ratios:

First	2.40 to 1
Second	.148 to 1
Third	.1 to 1
Reverse	.192 to 1

## Propeller Shaft

Tubular propeller shaft in two sections, with rubber mounted central pillow block. Front section connected to transmission by flexible joint and slip yoke. The second section is connected to the first and to rear axle by universal joints.

## Rear Axle

Final drive hypoid gear ratio: 10/39  
— with automatic transmission 12/43

## BRAKES

### Service

Hydraulically operated by pedal through vacuum servo and tandem master cylinder.

Disk type, with floating caliper and one cylinder to each wheel.

Independent front and rear circuits.

Proportioning valve in rear circuit for car load and deceleration rate variation compensations.

Device for automatic wear take-up.

### Parking

Mechanical, operating on rear brake.

## SUSPENSIONS

### Front

Independent wheels, by swinging arms, with coil springs and hydraulic, double-acting telescopic shock absorbers. Stabilizer bar. Sealed-for-life articulations.

### Rear

By rigid axle anchored to body through 5 reaction rods - 4 longitudinal and 1 transverse. Coil springs, hydraulic double-

acting telescopic shock absorbers. Asymmetric wheel motions stabilized by elastic mounts of reaction rods.

## STEERING AND WHEELS

### Steering

Standard L.H.D. Control; worm screw and roller, ratio 1/16.4. Steering shaft in three sections, incorporating two universal joints; breakaway mount.

Independent and symmetric track rods to each wheel, with central link rod. Sealed-for-life articulations.

Hydraulic, double-acting damper on relay support.

Turning circle 10.4 m (34ft2 in.)

Front wheel camber, measured at rim 0 to 6 mm (.00 to .24 in.) or  $30' \pm 30'$

Front wheel toe-in, measured at rim  $.3 \pm 2$  mm (.118 to .079 in.)

The above data apply to cars laden to the equivalent of 2 adults (300 lbs) plus 130 lbs of luggage.

### Wheels and Tires

Disk wheels, ventilated, with rim size 5 J x 13"

Radial-ply tires, size 165SR-13" or 185/60 R-14

# ELECTRICAL SYSTEM

Voltage 12 Volts

## Alternator

Continuous current rating . . . . . 65 Amps  
 Incorporated current rectifiers.  
 Automatic voltage regulator.  
 Cut-in speed at starting of engine (with users off),

## Battery

With grounded negative; capacity at 20-hr discharge rate . . . . . 60 Amp, hr.  
 Cold (—18°C) high-discharge test current . . . . . 255 Amp.

## Starter

Power rating . . . . . 1.3 kW  
 Direct engagement by solenoid and free-wheeling pinion.

## Heater Fan Motor

Power rating . . . . . 20 W

## Engine Radiator Fan Motor

Power rating . . . . . 110 W

## Windshield Wiper Motor

Power rating . . . . . 28 W

## Fuses

Nine 8-Amp, three 16-Amp fuses and two 8-Amp and 16-Amp fuses in separate holders.

## Bulbs

### Location

Headlights (high and low beams)

Front lamps

turn signal . . . . .  
 parking . . . . .

Rear lamps

turn signal . . . . .  
 back-up . . . . .  
 stop . . . . .

Rear lamps

tail . . . . .  
 license plate . . . . .

Courtesy light . . . . .

Ideogram illumination optical fiber light source.

«EX. GAS SENSOR») indicator

Selected gear indicator light (aut. transmissfon) . . . . .

Turn signal indicator.

Headlight high beam indicator . . . . .

Battery charge indicator.

Insufficient oil pressure indicator . . . . .

Fuel reserve indicator.

Parking and tail lamps indicator . . . . .

instrument cluster lights. . . . .

Fasten belts indicator.

Vehicular hazard warning signal indicator . . . . .

Low brake fluid level and hand brake ON indicator. . . . .

Side marker lights. . . . .

Vehicular hazard warning signal switch light . . . . .

Trunk lamp. . . . .

Cigar lighter housing indicator . . . . .

### SAE Standard

### FIAT Std. Part No.

« Sealed Beam » headlight unit 4002

No. 1034 (32 cp) 12V-5/21W  
 1/41461/90 Norm. 1/41446/90

No. 1063 (32 cp) 12V-21W  
 1/41460/90 Norm. 1/41481/90

No. 67 (4 cp) Norm. 1/08577/90  
 1/41459/90

— 12V-5W  
 — Norm. 1/08630/90

— 12V-3W  
 — Norm. 1/41439/90

No. 158 (2cp) Norm. 1/41458/90  
 or Norm. 1/41439/90

— 12V-1.2W  
 — Norm. 1/41437/90

— 12V-4W  
 — Norm. 1/41423/90

## MAIN DIMENSIONS

mm	520	847	1 013	1 120	1 250	1320	1350	1613	2 281	4141
in.	20,5	33,4	39,9	44	49,2	52	53,2	63,5	89,7	163

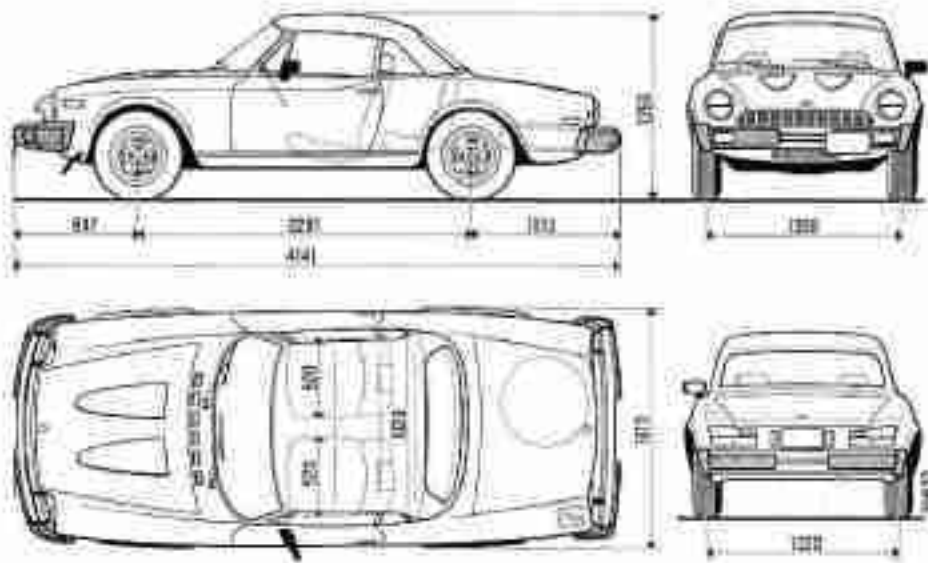

## PERFORMANCE

### Speeds

Maximum speeds after break-in, fully laden

	Manual T.	Auto-Transm
1st gear . . .	29	47
2nd gear . . .	50	76
3rd gear . . .	76	104
4th gear . . .	104	
5th gear, over	107	

### Gradeability

Maximum grades climbable, fully laden

	%	%
1st gear . . .	53	45
2nd gear . . .	26	25
3rd gear . . .	16	17
4th gear . . .	11	
5th gear, . . .	9,5	

## WEIGHTS

Curb weight) { manual . . . 2 360 lbs  
automatic . . . 2 400 lbs

Vehicle load capacity (total 430 lbs):

2 adults (300 lbs) + 130 lbs of luggage

Gross weight f manual . . . 2 790 lbs  
(fully laden) \ automatic . . . 2 830 lbs

Designated seating capacity . 2 persons

Occupant distribution . . . . 2 in front

Overall height is measured with unladen car. Trunk volume: 180cu.dm (6.4 cu. (t).



# FILLUP DATA

	dm <sup>3</sup> lt	Kg	U.S. units	
Fuel tank . . . . .	43	—	11.4 Gals	Unleaded gasoline <sup>1</sup> with octane rating of at least 91 (Research Method)
Radiator, cylinder jackets and heating system . . . . .	8	—	B% Qts	Antifreeze mixture <sup>(1)</sup>
Engine sump and filter <sup>(1)</sup> . . . . .	4.125	3.750	47, Qts	Low-ash content detergent oils-API Service SE to M1L-L-46152 and above the CCMC European Sequence. See Table below
Manual transmission . . . . .	1.65	1.50	<b>if km</b>	SAE BQW/90 oil containing special antiwear additives
Automatic transmission . . . . .	2.80	2.5	3 Qts	A.X.F., - Dexron typo fluid
Rear axle . . . . .	1.30	1.20	1 <sup>1</sup> / <sub>2</sub> Qts	EAE BOW/90 EP oil
Steering box . . . . .	.215	.195	<sup>2</sup> / <sub>15</sub> Pt	DOT 3 Motor Vehicle Brake Fluid to F.M.V.S.S. No. 116
Hydraulic brake circuits . . . . .	.380	.380	% Pt	
	Temperature		Solvent in bottle	Pure water plus high quality windshield washer solvent
Windshield washer . . . . .	above 0°C (32° F)		3%	
	downto—10°C (14°F)		50%	
	below —1°C (14°F)		100%	

Outdoor temperature		oltofaiat Single-grade	oliofiat Multigrade
Minimum below —15°C (5°F)		<b>VS+10</b> WSAE10W	
Minimum between —15° and 0° C (5°F to 32° F)		<b>VS+20</b> WSAE20W	
Minimum above 0°C (32° F)	Max. up to 35° C (95° F)	<b>VS+30</b> SAE30	<b>VS+ 15 W/40</b> SAE15W/40
	Max. over 35° C (95° F)	<b>VS+40</b> SAE40	

Do not mix oils of different brands or grades.

<sup>(1)</sup> The system is filled with a 50-50 mixture of water and Para-flu 11 fluid (SBB Page 36).

<sup>(1)</sup> Total capacity of sump, filter and lines is 4.35 kg (SVs Qts). The amount indicated is the requirement for periodical oil changes,

## Tire Pressure

Front and rear . . . . . 28 psi

**Note:** To obtain the required safety in car performance strictly adhere to the pressure rating given. Tire inflation pressure should be checked with cold tires.

# INDEX

## General

	Page
Identification data	2
Keys	2

## Operation

Automatic transmission	19
Doors	10
Driving the car	17
Fold-away top	14
Instruments and controls	5
Jacking-up and towing	22
Parking	18
Recommended shifting speeds	18
Seats	10
Seat belts	11
Starting the car	16
Starting the engine	16
Ventilation and heating	12
Wheel changing	21

## Maintenance

Advice for bodywork maintenance	49
Air cleaner	27
Antifreeze	36
Axle oil	39
Battery	43
Body care	42
Brakes	37
Brake fluid reservoir	37
Brake system bleeding	39

	Page
Clutch	38
Coolant circuit	36
Cooling system	36
Crankcase emission control system	30
Emission control systems	23
Electrical system	43
Engine lubrication	26
Engine oil filter	26
Exhaust emission control system	32
Fuel evaporative emission control system	32
Fuel filter	30
Fuel injection diagram	33
Fuel injection system	32
Fuses	44
General maintenance schedule	24
Hand parking brake	38
Headlights	46
Ignition timing	28
Inactivity	43
Lights	46
Lubricant designations	25
Miscellaneous	40
Oxygen Sensor	32
Power train	38
Spark plugs	27
Special maintenance	25

	Page
Steering	40
Steering articulations	40
Suspensions	40
Suspension articulations	40
Tapet clearance	26
Tires	40
Toolkit	41
Transmission oil	38
Water pump drive belt	28
Wheel bearings	40
Windshield washer	40
Windshield wiper	41

## Specifications

Brakes	60
Electrical system	61
Engine	59
Fill-up data	63
Main dimensions	62
Performance data	62
Power train	59
Steering and wheels	60
Suspensions	60
Weights	62

**Important** - All conversions are in U.S. units. They are given merely for Owners' convenience and, though the closest approximation is sought, are normally rounded off for practical reasons. **It must therefore be understood that in case of any discrepancy the metric units are the only valid reference.**



*The information contained in this publication is intended to be of a general nature only. The Fiat Company may at any time and from time to time, for technical or other necessary reasons, modify any of the details or specifications of the product described in this publication. To be sure of getting accurate, detailed and up-to-date information, an intending buyer should consult his nearest Fiat Dealer or distributor or branch.*



Direzione Commercials - Assistenza Tecnica • 10134 TORINO (Italia) • Cnr.: E. Giambone, 33  
FinAmi) S.p.A. 2nd Edition - Print No. S03.05.S38 - V-7380 - 4500 - Printed in Italy • Tipografia Torinese S.p.A. - Torino