

MBX50

SPECIFICATIONS

HAMECH

Cushion Tire Lift Trucks

LPG and GAS
4,000 – 6,500 LB CAPACITIES



MBX50 CUSHION TIRE LIFT TRUCKS

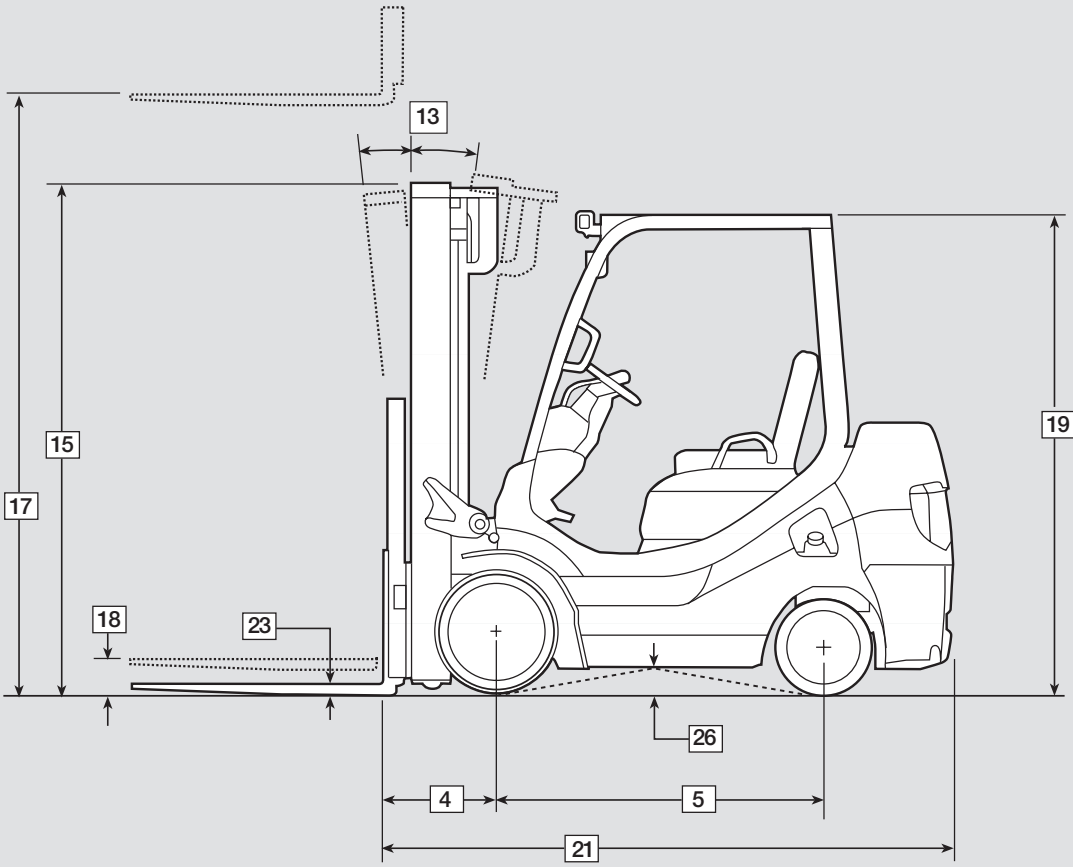
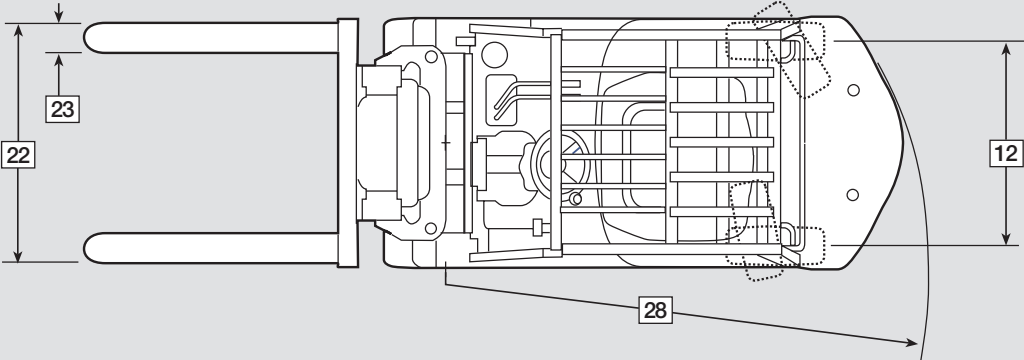

MBX50 CUSHION TIRE LIFT TRUCK SPECIFICATIONS

| GENERAL | | | G25SHT-16 | G28SHT-16 | G30SHT-16 | G32SHT-16 | | |
|-------------|---|----------------------------|------------------------------------|------------------------------------|----------------------------------|----------------------------------|----------------|----------------|
| 1 | Power Type | | Gasoline | Gasoline | Gasoline | Gasoline | | |
| 2 | Operation Type | | Sit-Down | Sit-Down | Sit-Down | Sit-Down | | |
| 3 | Capacity @ 24 in. (600 mm) load center* | lbs. (kg) | 5,000 (2,267) | 5,500 (2,495) | 6,000 (2,722) | 6,500 (2,948) | | |
| 4 | Load distance from center axle (2-stage) | in. (mm) | 16.9 (430) | 17.3 (440) | 17.3 (440) | 17.3 (440) | | |
| 5 | Wheelbase | in. (mm) | 55.1 (1,400) | 57.1 (1,450) | 57.1 (1,450) | 57.1 (1,450) | | |
| WEIGHT | | | | | | | | |
| 6 | Service weight (includes 2-stage std. mast & forks) | lbs. (kg) | 8,180 (3,710) | 8,840 (4,010) | 9,440 (4,280) | 9,920 (4,500) | | |
| 7 | Axle Loading | Loaded | Front | lbs. (kg) | 11,330 (5,140) | 12,350 (5,600) | 13,260 (6,015) | 14,000 (6,350) |
| | | | Rear | lbs. (kg) | 1,850 (840) | 2,000 (905) | 2,180 (990) | 2,430 (1,100) |
| | | Unloaded | Front | lbs. (kg) | 2,600 (1,180) | 2,820 (1,280) | 2,870 (1,300) | 2,740 (1,245) |
| | | | Rear | lbs. (kg) | 5,580 (2,530) | 6,020 (2,730) | 6,570 (2,980) | 7,180 (3,255) |
| TIRE | | | | | | | | |
| 8 | Tire type | | Cushion | Cushion | Cushion | Cushion | | |
| 9 | Tire size, front | | 21 - 7 - 15 | 21 - 8 - 15 | 21 - 8 - 15 | 21 - 8 - 15 | | |
| 10 | Tire size, rear | | 16.25 - 5 - 11.25 | 16.25 - 6 - 11.25 | 16.25 - 6 - 11.25 | 16.25 - 6 - 11.25 | | |
| 11 | Number of wheels, front/rear | x=driven | 2x / 2 | 2x / 2 | 2x / 2 | 2x / 2 | | |
| 12 | Tread (center of tires) | Front | in. (mm) | 34.6 (879) | 35.2 (895) | 35.2 (895) | 35.2 (895) | |
| | | Rear | in. (mm) | 35.4 (900) | 34.7 (880) | 34.7 (880) | 34.8 (885) | |
| DIMENSIONS | | | | | | | | |
| 13 | Tilting angle, 2-stage (FV) masts, fwd./bkwd. | deg. | 6 / 8 | 6 / 8 | 6 / 8 | 6 / 8 | | |
| 14 | Tilting angle, 3-stage (TFV) masts, fwd./bkwd. | deg. | 6 / 5 | 6 / 5 | 6 / 5 | 6 / 5 | | |
| 15 | Mast height, lowered (2-stage std. mast) | in. (mm) | 85.5 (2,170) | 85.5 (2,170) | 86.5 (2,197) | 88.6 (2,250) | | |
| 16 | Mast height, extended (2-stage std. mast)† | in. (mm) | 176 (4,470) | 176 (4,470) | 176 (4,470) | 176 (4,470) | | |
| 17 | Maximum fork height (2-stage std. mast)** | in. (mm) | 128 (3,250) | 128 (3,250) | 128 (3,250) | 128 (3,250) | | |
| 18 | Free lift height (2-stage std. mast) | in. (mm) | 5.5 (140) | 5.5 (140) | 5.5 (140) | 5.5 (140) | | |
| 19 | Height overhead guard | in. (mm) | 80.9 (2,055) | 80.9 (2,055) | 80.9 (2,055) | 80.9 (2,055) | | |
| 20 | Length, with standard forks | in. (mm) | 135.4 (3,440) | 136.6 (3,470) | 137.8 (3,500) | 139.2 (3,535) | | |
| 21 | Length to fork face (2-stage mast) | in. (mm) | 93.3 (2,370) | 94.5 (2,400) | 95.7 (2,430) | 97.1 (2,465) | | |
| 22 | Overall width, at drive tires (single) | in. (mm) | 42.1 (1,070) | 43.3 (1,100) | 43.3 (1,100) | 43.3 (1,100) | | |
| 23 | Forks, thickness x width x length | in. (mm) | 1.6 x 4 x 42 (40 x 100 x 1,070) | 1.6 x 4 x 42 (40 x 100 x 1,070) | 2 x 4 x 42 (50 x 125 x 1,070) | 2 x 4 x 42 (50 x 125 x 1,070) | | |
| 24 | Carriage width / ITA Class | in. (mm) | 37 (940) / II | 37 (940) / II | 37 (940) / III | 37 (940) / III | | |
| 25 | Ground clearance, under mast | in. (mm) | 5.5 (140) | 5.5 (140) | 5.5 (140) | 5.5 (140) | | |
| 26 | Ground clearance, center of wheelbase | in. (mm) | 3.9 (100) | 3.9 (100) | 3.9 (100) | 3.9 (100) | | |
| 27 | Right angle stacking aisle (2-stage mast)†† | in. (mm) | 94.5 (2,400) | 96.8 (2,460) | 98.8 (2,510) | 100 (2,540) | | |
| 28 | Turning radius, outside | in. (mm) | 77.6 (1,970) | 79.5 (2,020) | 81.5 (2,070) | 82.7 (2,100) | | |
| PERFORMANCE | | | | | | | | |
| 29 | Travel speed, forward, loaded/unloaded | mph (km/h) | 10.6 (17) / 10.6 (17) | 10.6 (17) / 10.6 (17) | 10.6 (17) / 10.6 (17) | 10.6 (17) / 10.6 (17) | | |
| 30 | Lifting speed, loaded/unloaded (2-stage mast) | fpm (mm/s) | 120 (610) / 124 (630) | 112 (570) / 124 (630) | 104 (530) / 124 (630) | 104 (530) / 108 (550) | | |
| 31 | Lowering speed, loaded/unloaded (2-stage mast) | fpm (mm/s) | 98 (500) / 98 (500) | 98 (500) / 98 (500) | 98 (500) / 98 (500) | 98 (500) / 98 (500) | | |
| 32 | Maximum drawbar pull, loaded | lbs. (kN) | 5,513 (24.5) | 5,513 (24.5) | 5,513 (24.5) | 5,175 (23) | | |
| 33 | Maximum gradability | % | 39 | 33 | 31 | 28.5 | | |
| 34 | Service brake, operation / control | | Foot / Hydraulic | Foot / Hydraulic | Foot / Hydraulic | Foot / Hydraulic | | |
| 35 | Parking brake, operation / control | | Hand / Mechanical | Hand / Mechanical | Hand / Mechanical | Hand / Mechanical | | |
| 36 | Steering, type | | FHPS | FHPS | FHPS | FHPS | | |
| DRIVE | | | | | | | | |
| 37 | Engine Manufacturer / Engine model | | Nissan / K25 | Nissan / K25 | Nissan / K25 | Nissan / K25 | | |
| 38 | Rated output (SAE Gross) | HP (kW) @ rpm | 60 (44) @ 2,700 | 60 (44) @ 2,700 | 60 (44) @ 2,700 | 60 (44) @ 2,700 | | |
| 39 | Maximum torque (SAE Gross) | lb. - ft. (Nm) @ rpm | 142 (193) @ 1,600 | 142 (193) @ 1,600 | 142 (193) @ 1,600 | 142 (193) @ 1,600 | | |
| 40 | No. of cylinders/ displacement | cu. in. (cm ³) | 4 / 152 (2,488) | 4 / 152 (2,488) | 4 / 152 (2,488) | 4 / 152 (2,488) | | |
| 41 | Fuel tank capacity | U.S. gallons (liters) | 10.1 (38.4) | 10.1 (38.4) | 10.1 (38.4) | 10.1 (38.4) | | |
| OTHER | | | | | | | | |
| 42 | Relief pressure, maximum | psi (bar) | 2,650 (181) | 2,650 (181) | 2,650 (181) | 2,650 (181) | | |
| 43 | Transmission | | Powershift | Powershift | Powershift | Powershift | | |
| 44 | Sound level, at operator ears | dB | 83 | 83 | 83 | 83 | | |

NOTE: Most values shown in this publication are rounded. Therefore, direct conversion between metric and English or Imperial may be slightly different from those shown. The performance of machines is affected by the condition of the truck and how it is equipped, as well as the nature and condition of the operating area.

If these specifications are critical or if you need exceed the specifications shown here, discuss the proposed application with your authorized dealer.

*Optional masts, attachments, longer load dimensions, and higher lifting heights may result in downrating of the capacity. Contact your authorized dealer.

**Other mast heights available. See MAST DATA chart for other standard mast heights. Contact your authorized dealer.

†Includes 48-inch (1,220 mm) high load backrest. Contact your authorized dealer.

††Add load distance and clearance. Contact your authorized dealer.

MBX50 CUSHION TIRE LIFT TRUCK SPECIFICATIONS

| GENERAL | | | | G20ST-16 | G20SHT-16 | G25ST-16 |
|-------------|--|----------------------------|----------|--------------------------------------|--------------------------------------|------------------------------------|
| 1 | Power Type | | | Gasoline | Gasoline | Gasoline |
| 2 | Operation Type | | | Sit-Down | Sit-Down | Sit-Down |
| 3 | Capacity @ 24 in. (600 mm) load center* | lbs. (kg) | | 4,000 (1,810) | 4,000 (1,810) | 5,000 (2,267) |
| 4 | Load distance from center axle (2-stage) | in. (mm) | | 16.9 (430) | 16.9 (430) | 16.9 (430) |
| 5 | Wheelbase | in. (mm) | | 55.1 (1,400) | 55.1 (1,400) | 55.1 (1,400) |
| WEIGHT | | | | | | |
| 6 | Service weight (includes 2-stage std. mast & forks) | lbs. (kg) | | 7,300 (3,310) | 7,300 (3,310) | 8,180 (3,710) |
| 7 | Axle Loading | Loaded | Front | lbs. (kg) | 9,820 (4,455) | 11,330 (5,140) |
| | | | Rear | lbs. (kg) | 1,480 (670) | 1,850 (840) |
| | | Unloaded | Front | lbs. (kg) | 2,820 (1,280) | 2,600 (1,180) |
| | | | Rear | lbs. (kg) | 4,480 (2,030) | 5,580 (2,530) |
| TIRE | | | | | | |
| 8 | Tire type | | | Cushion | Cushion | Cushion |
| 9 | Tire size, front | | | 21 - 7 - 15 | 21 - 7 - 15 | 21 - 7 - 15 |
| 10 | Tire size, rear | | | 16.25 - 5 - 11.25 | 16.25 - 5 - 11.25 | 16.25 - 5 - 11.25 |
| 11 | Number of wheels, front / rear | x=driven | | 2x / 2 | 2x / 2 | 2x / 2 |
| 12 | Tread (center of tires) | Front | in. (mm) | 34.6 (879) | 34.6 (879) | 34.6 (879) |
| | | Rear | in. (mm) | 35.4 (900) | 35.4 (900) | 35.4 (900) |
| DIMENSIONS | | | | | | |
| 13 | Tilting angle, 2-stage (FV) masts, forward / backward | deg. | | 6 / 8 | 6 / 8 | 6 / 8 |
| 14 | Tilting angle, 3-stage (TFV) masts, forward / backward | deg. | | 6 / 5 | 6 / 5 | 6 / 5 |
| 15 | Mast height, lowered (2-stage std. mast) | in. (mm) | | 85.5 (2,170) | 85.5 (2,170) | 85.5 (2,170) |
| 16 | Mast height, extended (2-stage std. mast)† | in. (mm) | | 176 (4,470) | 176 (4,470) | 176 (4,470) |
| 17 | Maximum fork height (2-stage std. mast)** | in. (mm) | | 128 (3,250) | 128 (3,250) | 128 (3,250) |
| 18 | Free lift height (2-stage std. mast) | in. (mm) | | 5.5 (140) | 5.5 (140) | 5.5 (140) |
| 19 | Height overhead guard | in. (mm) | | 80.9 (2,055) | 80.9 (2,055) | 80.9 (2,055) |
| 20 | Length, with standard forks | in. (mm) | | 132.9 (3,375) | 132.9 (3,375) | 135.4 (3,440) |
| 21 | Length to fork face (2-stage mast) | in. (mm) | | 90.8 (2,305) | 90.8 (2,305) | 93.3 (2,370) |
| 22 | Overall width, at drive tires (single) | in. (mm) | | 42.1 (1,070) | 42.1 (1,070) | 42.1 (1,070) |
| 23 | Forks, thickness x width x length | in. (mm) | | 1.6 x 3.9 x 42 (40 x 100 x 1,070) | 1.6 x 3.9 x 42 (40 x 100 x 1,070) | 1.6 x 4 x 42 (40 x 100 x 1,070) |
| 24 | Carriage width / ITA Class | in. (mm) | | 37 (940) / II | 37 (940) / II | 37 (940) / II |
| 25 | Ground clearance, under mast | in. (mm) | | 5.5 (140) | 5.5 (140) | 5.5 (140) |
| 26 | Ground clearance, center of wheelbase | in. (mm) | | 3.9 (100) | 3.9 (100) | 3.9 (100) |
| 27 | Right angle stacking aisle (2-stage mast)†† | in. (mm) | | 92.5 (2,350) | 92.5 (2,350) | 94.5 (2,400) |
| 28 | Turning radius, outside | in. (mm) | | 75.6 (1,920) | 75.6 (1,920) | 77.6 (1,970) |
| PERFORMANCE | | | | | | |
| 29 | Travel speed, forward, loaded / unloaded | mph (km/h) | | 10.6 (17) / 10.6 (17) | 10.6 (17) / 10.6 (17) | 10.6 (17) / 10.6 (17) |
| 30 | Lifting speed, loaded / unloaded (2-stage mast) | fpm (mm/s) | | 120 (610) / 124 (630) | 120 (610) / 124 (630) | 120 (610) / 124 (630) |
| 31 | Lowering speed, loaded / unloaded (2-stage mast) | fpm (mm/s) | | 98 (500) / 98 (500) | 98 (500) / 98 (500) | 98 (500) / 98 (500) |
| 32 | Maximum drawbar pull, loaded | lbs. (kN) | | 4,343 (19.3) | 5,513 (24.5) | 4,343 (19.3) |
| 33 | Maximum gradability | % | | 36 | 47 | 30 |
| 34 | Service brake, operation / control | | | Foot / Hydraulic | Foot / Hydraulic | Foot / Hydraulic |
| 35 | Parking brake, operation / control | | | Hand / Mechanical | Hand / Mechanical | Hand / Mechanical |
| 36 | Steering, type | | | FHPS | FHPS | FHPS |
| DRIVE | | | | | | |
| 37 | Engine Manufacturer / Engine model | | | Nissan / K21 | Nissan / K25 | Nissan / K21 |
| 38 | Rated output (SAE Gross) | HP (kW) @ rpm | | 56 (41) @ 2,700 | 60 (44) @ 2,700 | 56 (41) @ 2,700 |
| 39 | Maximum torque (SAE Gross) | lb. - ft. (Nm) @ rpm | | 119 (160) @ 1,600 | 142 (193) @ 1,600 | 119 (160) @ 1,600 |
| 40 | No. of cylinders / displacement | cu. in. (cm ³) | | 4 / 126 (2,065) | 4 / 152 (2,488) | 4 / 126 (2,065) |
| 41 | Fuel tank capacity | U.S. gallons (liters) | | 10.1 (38.4) | 10.1 (38.4) | 10.1 (38.4) |
| OTHER | | | | | | |
| 42 | Relief pressure, maximum | psi (bar) | | 2,650 (181) | 2,650 (181) | 2,650 (181) |
| 43 | Transmission | | | Powershift | Powershift | Powershift |
| 44 | Sound level, at operator ears | dB | | 82 | 83 | 83 |

NOTE: Most values shown in this publication are rounded. Therefore, direct conversion between metric and English or Imperial may be slightly different from those shown. The performance of machines is affected by the condition of the truck and how it is equipped, as well as the nature and condition of the operating area. If these specifications are critical or if your needs exceed the specifications shown here, discuss the proposed application with your authorized dealer.

*Optional masts, attachments, longer load dimensions, and higher lifting heights may result in downrating of the capacity. Contact your authorized dealer.

**Other mast heights available. See MAST DATA chart for other standard mast heights. Contact your authorized dealer.

†Includes 48-inch (1,220 mm) high load backrest. Contact your authorized dealer.

††Add load distance and clearance. Contact your authorized dealer.

MBX50 TRUCK DATA AND FEATURES

| Maximum Fork Height in. (mm) | Mast Height Lowered in. (mm) | Mast Height Extended in. (mm) | Free Lift in. (mm) |
|---|------------------------------|-------------------------------|--------------------|
| G20/25 2-STAGE FREE VIEW (FV) | | | |
| 82 (2,080) | 62.5 (1,585) | 130 (3,300) | 5.5 (140) |
| 106 (2,690) | 74.5 (1,890) | 154 (3,910) | 5.5 (140) |
| 114 (2,895) | 78.5 (1,995) | 162 (4,115) | 5.5 (140) |
| 128 (3,250) | 85.5 (2,170) | 176 (4,470) | 5.5 (140) |
| 146 (3,705) | 94.5 (2,400) | 194 (4,925) | 5.5 (140) |
| 158 (4,010) | 100.5 (2,550) | 206 (5,230) | 5.5 (140) |
| G20/25 2-STAGE FULL FREE VIEW (FFV) | | | |
| 106 (2,690) | 74.5 (1,890) | 154 (3,910) | 26.5 (670) |
| 114 (2,895) | 78.5 (1,995) | 162 (4,115) | 30.5 (775) |
| 128 (3,250) | 85.5 (2,170) | 176 (4,470) | 37.5 (950) |
| G20/25 3-STAGE FULL FREE VIEW (TFV) | | | |
| 152.5 (3,870) | 73.5 (1,865) | 200.5 (5,090) | 25.5 (645) |
| 167.5 (4,255) | 78.5 (1,995) | 215.5 (5,475) | 30.5 (775) |
| 188.5 (4,785) | 85.5 (2,170) | 236.5 (6,010) | 37.5 (950) |
| 198.5 (5,040) | 89.5 (2,275) | 246.5 (6,260) | 41.5 (1,055) |
| 216.5 (5,500) | 97.5 (2,475) | 264.5 (6,720) | 49.5 (1,255) |
| 235.5 (5,980) | 106.5 (2,705) | 283.5 (7,200) | 58.5 (1,485) |
| G28/30 2-STAGE FREE VIEW (FV) | | | |
| 82 (2,080) | 62.5 (1,585) | 130 (3,300) | 5.5 (140) |
| 106 (2,690) | 74.5 (1,890) | 154 (3,910) | 5.5 (140) |
| 114 (2,895) | 78.5 (1,995) | 162 (4,115) | 5.5 (140) |
| 128 (3,250) | 85.5 (2,170) | 176 (4,470) | 5.5 (140) |
| 146 (3,705) | 94.5 (2,400) | 194 (4,925) | 5.5 (140) |
| 158 (4,010) | 100.5 (2,550) | 206 (5,230) | 5.5 (140) |
| G(D)28/30 2-STAGE FULL FREE VIEW (FFV) | | | |
| 106.5 (2,690) | 75.5 (1,915) | 154 (3,910) | 26.5 (670) |
| 114.5 (2,905) | 79.5 (2,020) | 162.5 (4,125) | 31.5 (800) |
| 128.5 (3,260) | 86.5 (2,195) | 176.5 (4,480) | 38.5 (975) |
| G(D)28/30 3-STAGE FULL FREE VIEW (TFV) | | | |
| 150.5 (3,820) | 74.5 (1,890) | 198.5 (5,040) | 26.5 (670) |
| 162.5 (4,125) | 78.5 (1,995) | 210.5 (5,345) | 30.5 (775) |
| 183.5 (4,660) | 85.5 (2,170) | 231.5 (5,880) | 37.5 (950) |
| 190.5 (4,835) | 88.5 (2,245) | 238.5 (6,055) | 40.5 (1,025) |
| 217.5 (5,525) | 99.5 (2,530) | 265.5 (6,745) | 51.5 (1,310) |
| 230.5 (5,855) | 106.5 (2,705) | 278.5 (7,070) | 58.5 (1,485) |
| G(D)32 2-STAGE FREE VIEW (FV) | | | |
| 82 (2,080) | 65.5 (1,665) | 130 (3,300) | 5.5 (140) |
| 106 (2,690) | 77.5 (1,970) | 154 (3,910) | 5.5 (140) |
| 114 (2,895) | 81.5 (2,070) | 162 (4,115) | 5.5 (140) |
| 128 (3,250) | 88.5 (2,250) | 176 (4,470) | 5.5 (140) |
| 146 (3,705) | 97.5 (2,475) | 194 (4,925) | 5.5 (140) |
| 158 (4,010) | 103.5 (2,630) | 206 (5,230) | 5.5 (140) |
| G(D)32 3-STAGE FULL FREE VIEW (TFV) | | | |
| 150.5 (3,820) | 76.5 (1,945) | 198.5 (5,040) | 28.5 (725) |
| 162.5 (4,125) | 80.5 (2,045) | 210.5 (5,345) | 32.5 (825) |
| 183.5 (4,660) | 87.5 (2,220) | 231.5 (5,880) | 39.5 (1,005) |
| 189.5 (4,810) | 91.5 (2,325) | 237.5 (6,030) | 43.5 (1,105) |
| 217.5 (5,525) | 103.5 (2,630) | 265.5 (6,740) | 55.5 (1,410) |
| 230.5 (5,855) | 110.5 (2,805) | 278.5 (7,070) | 62.5 (1,585) |

NOTE: Specifications for 4-Stage Full Free View (QFV) Masts are not indicated. Please consult your authorized dealer for information and availability.

FEATURES AND EQUIPMENT

SPECIAL FEATURES

- EPA Tier II compliant K21 and K25 industrial engine with high torque at low RPMs for power and fuel efficiency
- Dual floating structure uses drive-train cushion mounts and suspension compartment mounts to isolate the operator from engine and floor vibration
- Hydraulic System with tandem pump provides fast and controllable lifting speed at low engine RPM
- New full floating transmission with high-capacity oil cooler for the torque converter, aluminum alloy transmission case for better heat dissipation, and highly reliable, dust-resistant, double-sealed universal joint design
- Self-adjusting brakes with thicker drums improve heat resistance in severe duty applications
- Improved steer axle with integral double-acting, double-ended cylinder, high-capacity king-pin needle bearings, and heavy-duty seals
- Mast with large visibility window, combined with low profile dash display, offers the operator an unrestricted view to the fork tips and surrounding area
- Operator presence system locks out lift, lower, tilt and travel functions when the operator leaves the seat for longer than three seconds

STANDARD EQUIPMENT

- New low profile dash display – Fuel Gauge, Water Temperature Gauge and Hour Meter
- Indicator lights – Neutral/Return to Neutral, Low Oil Pressure, Low Battery/Alternator, Hydraulic Lock (Operator Presence), Check Engine Warning, Maintenance Error Code
- Drawbar Pin in Counterweight
- Electronic Ignition, Anti-Restart Ignition Switch
- Fully Hydrostatic Power Steering
- Long-Life Headlights (OHG Mounted)
- LED Tail/Stop/Rear Turn Lights
- High-Mount Air Intake
- Horn with Actuator on Center of Steering Wheel
- Three-Piece Overhead Guard
- Seat and Operator Restraint System with Lap Belt
- Three-Function Hydraulic Control Valve
- Parking Brake with Double-Action Release
- Tilting Steering Column
- Large, Open Floor Space with Operator Compartment Suspended-Mount Pedals
- Transmission Torque Converter Oil Cooler
- Load Backrest

- Spacious Step Area, Large Entry Handgrip and Wide-Open Floor Space allows easy entry/exit
- Engine Protection System
- ITA Class II or Class III Fork Carriage
- ITA Class II or Class III Forks
- Critical Wiring Harness Connectors are Waterproof
- Contoured, Easy-to-Grip, Hydraulic Control Lever Knobs

OPTIONAL EQUIPMENT

- Warning Lights & Audible Travel Alarms
- Economy Mode Package
- Tilt Cylinder Boots
- Cotton-Core Radiator
- Spinner Knob Steering Wheel
- Dual-Fuel System Optional Fork Lengths
- Sideshifter – Integral or Hang-On
- 4-Way Valve and Internal Hosing
- Special Tires
- Full Suspension Seat
- Fire Extinguisher
- Attachments
- Rear-view mirrors

TECHNICAL DATA

ENGINE

K21 (2.1 liter) or K25 (2.5 liter) gasoline/LPG, 4-cylinder, in-line engines with Engine Concentrated Control Systems (ECCS) exceed EPA emissions standards. These low-RPM, high-torque industrial engines offer reduced maintenance requirements, exceptional emissions controls, fast acceleration, high performance, reliable durability and enhanced serviceability.

- There are three engine fuel choices: gasoline multi-port fuel injection, LPG single-port (throttle body) fuel injection, or a dual-fuel system with easy switching at the flip of a switch. All engines are equipped with 3-way catalytic converters and closed-loop exhaust systems.
- All engines utilize an ECCS that continuously monitors data from the fuel pressure, accelerator throttle position, mass air-flow sensor, and heated oxygen sensor – for improved fuel economy, smooth operation, reliable starting in cold weather, and high performance throughout the operating range. An electronic throttle governor protects the engine against over-rev damage.
- Crankshaft and camshaft position sensors provide information to the ECCS for optimum ignition and fuel injection timing. Each cylinder has an individual ignition coil for precise control and reliability.

- An engine coolant temperature sensor and controller protects the engine against damage due to high engine temperature by automatically limiting engine speed during high-temperature operation. If the engine coolant temperature exceeds safe operation temperature, the engine will be shut down. An illuminated indicator on the instrument console indicates high-temperature operation, and gives the operator warning of engine shutdown.
- The aluminum alloy cylinder head has large intake and exhaust valves and a semi-hemispherical combustion chamber for efficient fuel consumption.
- The engine block is designed with five main bearings. All main and rod bearings are micro-grooved to improve lubrication and reduce wear.

FUEL SYSTEM

Gasoline, LPG, or Dual-Fuel systems are available. The gasoline fuel tank is integral to the truck frame.

- In-tank mounted gasoline fuel delivery pump, fuel-level sensing unit, pressure regulator and filter are standard.
- LPG fuel system uses single-point, throttle body fuel injection. A removable 33 lb. or 43 lb. fuel tank is available with stationary, fold-back, or swing-out-and-down tank mountings.

COOLING SYSTEM

The high-capacity aluminum radiator is designed with an efficient thermal transfer fin and integral oil cooler for the transmission torque converter.

- System design allows easy access to the reservoir for checking the coolant level.
- High-volume cooling fan uses flexible plastic blades and shroud for maximum air volume and noise reduction.

ELECTRICAL SYSTEM

Standard instrument package and operator conveniences:

- 12-volt electrical system
- 50A alternator with built-in IC regulator
- Key-lock, anti-restart ignition switch
- High-torque, low-amp starter motor with planetary gear reduction
- Waterproof electrical connectors
- Electric fuel gauge, water temperature gauge, LCD hour meter
- Indicator lights for Neutral/Return to Neutral, Low Oil Pressure, Low Battery/Alternator Output, Check Engine Warning, Hydraulic Lock (Operator Presence), and ECCS Status Code
- ECCS Service Support Tool connector for rapid system diagnostics

HYDRAULIC SYSTEM

The Hydraulic System features a tandem pump assembly with separate pumps for load handling and steering. This enables faster lifting at engine idle speed for greater fuel economy and performance levels.

- Large hydraulic fluid reservoir integral to the truck frame reduces heat buildup in the system.
- Load sensing valve in the hydraulic circuit reduces the flow of oil to the power steering system when steering wheel is idle.
- Hydraulic System is fully filtered and features a powerful and efficient direct drive gear pump.

FRAME

An all-welded assembly with heavy-gauge steel and integral hydraulic and fuel tanks provide exceptional durability.

- Welded front cross-member and bolted drive axle increase frame rigidity.
- Loads are transferred directly from the mast to the drive axle and onto the floor without being transmitted through the frame, reducing frame stress.
- Wide, open step is designed into the frame assembly without compromising the structure.

DRIVE AXLE

A heavy-duty, cast steel drive axle housing supports the load and chassis without placing a load on the free-floating axle shafts. A flange is mounted to the truck frame to improve load distribution and reduce frame flexing.

TRANSMISSION

Komatsu single-speed, powershift transmission is specifically designed for industrial applications.

- Column-mounted electrical shift lever gives the operator easy directional control without removing a hand from the steering wheel.
- Optimized stall ratio for torque converter provides high torque without sacrificing travel speed.
- A modulating control valve absorbs initial pressure spikes during initial engagement and directional change. This improves shifting capabilities and prolongs the life of the entire drive train.
- Transmission oil is double-filtered by a 125-micron mesh on pickup, and a 35-micron cartridge on the return line.
- Transmission oil cooler is integral with the radiator.
- Inching control and auxiliary brake pedal combination allows the operator precise truck positioning with positive control.

BRAKES

Hydraulic brakes are self-energizing and self-adjusting.

- Brake fluid reservoir is located under the console cover for fast, easy inspection and maintenance.
- Heavy-duty brake backing plate and thick brake drum provide reliable braking action and reduced heat.
- Mechanical parking brake has two-stage latching mechanism for positive engagement.

STEER AXLE

Fully Hydrostatic Power Steering is standard.

- Independent power steering pump separates steering function from main hydraulics for smoother, more reliable action.
- Heavy-duty fabricated steer axle has double-acting, double-ended power steering cylinder and no drag links or tie rods.
- Steering stops are machined into the steering cylinder to reduce stress impact on steering linkages.
- Grease fittings on all linkages are accessible without lifting the truck.

MAST, CARRIAGE, LBR AND FORKS

High-visibility mast assembly has a 6-roller carriage that is available in two-, three-, and four-stage Free Lift, Free View designs.

- Sealed bearings require no maintenance.
- Angle-mounted bearings and a shaped rail flange prevent excessive wear and friction, while maintaining correct side thrust clearance.
- ITA Class II or Class III carriages accept a variety of fork sizes and common load-handling attachments.
- 48-inch-high load backrest is standard for increased load control and operator protection.
- Single or double auxiliary hydraulic-function internal hose routing is available.

OPERATOR COMPARTMENT

A unique suspension compartment isolates the operator from the floor surface and from engine vibration, for greater operator comfort and productivity.

- Comfort seat has built-in lumbar support, retractable seat belt, lateral restraint system, and fore and aft adjustment.
- Hydraulic control levers are positioned for optimum access and ease of use. International symbols on the contoured grips indicate the function.
- Tilting steering console has small-diameter steering wheel and electronic instrumentation. Tilt is infinitely adjustable, with extended room between the engine cover and console.

- Wide-open floorboard has suspended brake and inching pedals with ribbed rubber pads for comfort and safety. Integral accelerator mechanism has a transfer roller for smooth operation.
- Full-width rubber floor mat provides a large, non-slip surface and reduces noise, vibration and heat.
- Open step in the frame with a traction surface and a large handgrip provide easy entry and exit for the operator.
- Standard headlight/turn indicator control lever is mounted on the steering column for easy use.
- Full-width overhead guard provides excellent visibility for high stacking and meets or exceeds ITSDF requirements.

SERVICEABILITY

The engine and transmission can be easily accessed for daily inspection without the use of any tools.

- Single-piece, all-steel engine cover and seat support is fully insulated to reduce noise and heat transfer.
- Engine cover has gas-filled cylinder with an automatic locking device to assist in opening and to prevent the cover from unexpectedly closing.
- Easy-access, easy-operation engine cover latch is recessed to prevent interference when entering and exiting the operator compartment.
- Engine cover is shaped for easy access into the engine area for maintenance and service.

COMPLIANCE, APPROVALS AND ENVIRONMENTAL CONCERNS

Designed for maximum recycling at end of life, with special attention to materials and construction. Counterweight designed for breakup during recycling process. Transmission case is recyclable aluminum.

Hamech Lift Trucks meet or exceed American National Standard Institute, ITSDF B56.1-Part III Safety Standards for Powered Industrial Trucks.

Compliant with UL 558 for the appropriate truck type. Contact your dealer for application-specific requirements. Meets or exceeds EPA emissions standards.

Expect solid support nationwide

Hamech, a brand of Crown Equipment Corporation, offers a comprehensive service support network for Hamech LPG, gas or diesel lift trucks.

You can expect ongoing value with the comprehensive services available from your Hamech dealer. See it for yourself in state-of-the-art facilities stocked with products and parts inventories, advanced processes, equipment and tools. It's also apparent in the professionally trained service technicians and well-stocked service vans.

In addition, you can count on Hamech for operator and service technician training, flexible maintenance programs, fleet management and financial services. Hamech's association with Crown also assures you of access to industry-leading electric lift trucks for complete application flexibility.

Visit hamech.com for more information on the full line of Hamech IC lift trucks.



HAMECH

Hamech Lift Trucks

New Bremen, Ohio 45869 USA

Tel 419-629-2311

Fax 419-629-3796

Hamech is a brand of Crown Equipment Corporation.

Because Hamech is continually improving its products, specifications are subject to change without notice.

Hamech and the Hamech logo are trademarks of Crown Equipment Corporation.

Copyright 2008 Crown Equipment Corporation
SF14887 03/08
Printed in U.S.A.