

# ORACLE AUDIO

*The Fine Art of Playing Music*



Oracle Audio Technologies  
CD 2500 MK II player  
CD 2000 Transport

# Owner's Manual

## FOREWORD

---

This is your CD Owner's Manual. The following pages will describe as succinctly as possible the assembly of your new CD. Although some operations are self explanatory, we strongly suggest you read this booklet to better understand the importance of the different key adjustments.

Your CD is a precision instrument and its performance will be affected by the different adjustments. It is important to set up your CD with the utmost care for an outstanding musical performance and enjoyment!

## FOR YOUR RECORDS

---

Oracle CD Serial Number: \_\_\_\_\_

Power Supply Serial Number: \_\_\_\_\_

Dealer's Name: \_\_\_\_\_

Dealer's Address: \_\_\_\_\_

Dealer's Phone: \_\_\_\_\_

Purchase Date: \_\_\_\_\_

We suggest you keep your sales slip together with this owner's guide.



## TABLE OF CONTENTS

Content .....	4
Pack and unpack your CD .....	5
Suspension Fine Tuning .....	7
Connection Procedure .....	9
Power Supply Connection.....	11
Magnetic Disc Clamp .....	12
Operating Instructions.....	13
Remote Control.....	15
Laser Lens Cleaning .....	18
Fuse Replacement.....	19
Specifications.....	20

## CONTENT

---

We developed this packing material so that your new Oracle Audio CD 2500 MK II player / CD 2000 transport is afforded maximum protection.

It consists of:

- A double layer cardboard box
- A module of foam packaging for the accessories
- A wooden frame with internal foam packing, protecting the CD turntable itself. It is very important to preserve this packaging material since it is the only really safe method of transporting your Oracle CD turntable.

The following items are located in **the upper foam structure**:

- 4 suspension covers
- Magnetic disc clamp
- Aluminium top cover
- Oracle Power supply
- Suspension calibration tool
- Brilliance cleaner and lint free blue cloth
- AC power cord
- 15 pin DC signal cord
- Remote control handset and batteries

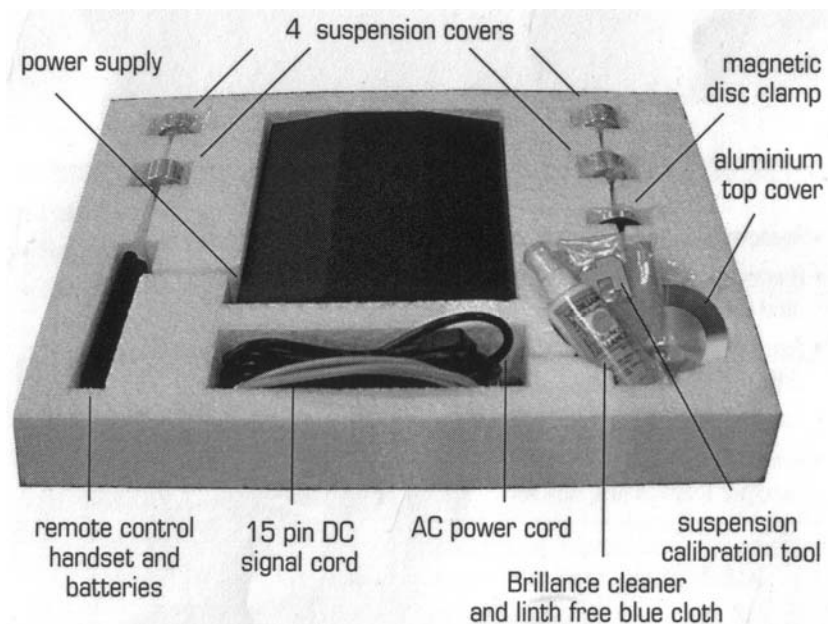

The following items are located in **the wooden module**:

- 1 CD turntable assembly
- 1 plinth assembly including:
  - 4 suspensions towers
  - 1 display module assembly
- 1 main CD turntable chassis assembly
- 2 main chassis protective foam end caps
- 1 main chassis hold down "C" shape foam spacer block

## **PACK AND UNPACK YOUR CD**

---

**Tools needed – Phillips (cross head) or Pozidrive screw driver**  
**– Small needle pliers**

- Open the external box.
- Carefully remove the 4 white foam protection corners.
- Turn the brown box on its side so you can pull out the white internal cardboard box.
- Carefully slide the white box out and stand it flat with the arrows on the side pointing up.
- Open the box first by opening the end flaps then the front.
- Remove the white foam layer to access the wooden box, set it aside.

### **Accessories Foam Block**

- Remove the power supply, power cord and DC cord, put it aside.
- Remove the aluminium top cover and the Brilliance cleaner.
- Remove the remote control and install the batteries.
- Remove the magnetic disc clamp.
- Remove the suspension covers and put them to one side for later installation.
- The suspension covers will be installed following the suspension fine tuning should this be required.



- Remove the wooden top cover using your Phillips screwdriver.
- Grasp the plastic protective bag at each end using the handles and lift the whole Oracle player unit out of the box.

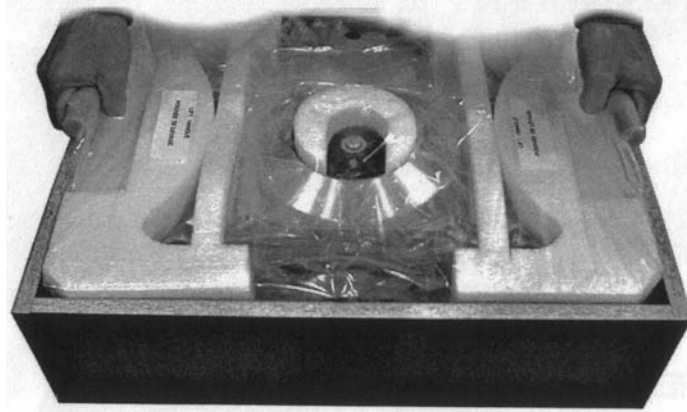

- Open the plastic bag at one end only and remove the foam protective end cap.
- Hold the plinth and slide the CD turntable assembly out of the bag.
- Remove the “C” shape, hold down spacer block.
- Remove the inner protective bag.

**Note:** Place the inner bag, the 2 protective end caps and the “C” shape hold down spacer blocks back in the wooden box thus making sure they do not get lost. Put the wooden top cover back up.

**Note:** When repackaging, it is important to use this inner protective bag to prevent surface damage to the clear lacquer finish.

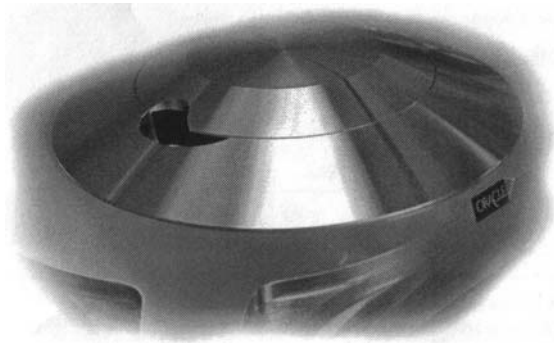

## SUSPENSION FINE TUNING

---

**Caution!** Do not attempt to lift the main chassis from the suspension towers as this could damage the connecting cable between the display module and the main chassis. If the main chassis needs to be removed, a special technical document is available from **Oracle Audio Technologies** or your local area distributor. This work should always be carried out by an experienced and competent technician.

- Place your Oracle CD player on a flat surface to complete the set up procedure.

### Suspension fin Tuning

The suspension of your Oracle CD turntable has been calibrated at the factory but it **possibly** might require minor fine-tuning before putting the player into service. To help with this we have supplied a **suspension calibration tool** to assist with accurate measurement and calibration of each suspension tower.

**Note:** Before beginning this step, very carefully seat the aluminium top cover above the compact disc in its specially machined recess and position, so that the two finger slots match the one on the player main chassis. The slightly curved section of the finger slots should be facing the front of the unit. This will give a more accurate operational mass of the main chassis.

This picture indicates the target setting of the suspension system.

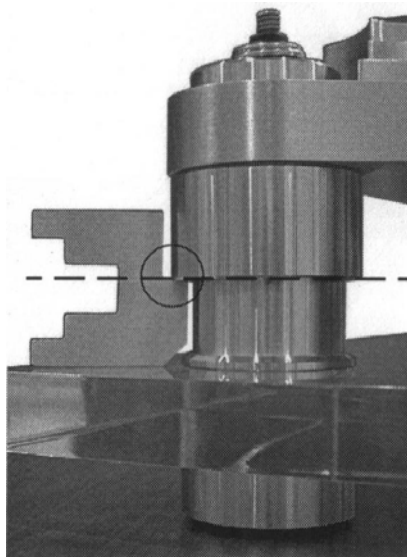

The tool supplied will help you determine if a suspension fine tuning is required. If no or only minor changes need to be performed, you might select to leave the system as it is. At this point, the suspension top covers can be installed and the player moved to its final playing location. To complete the final leveling of the plinth, it will be necessary to use a spirit level. The leveling will be achieved by adjusting the height of the threaded feet under the plinth.

**Note:** The reference to clockwise or counter-clockwise is determined by viewing the spring module from above. To proceed with minor changes to the suspension fine tuning, please read the following information.

**Make the Suspension Housing Sit Lower**

If the suspension housing is sitting high as on this picture.

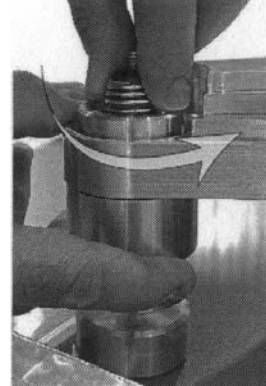
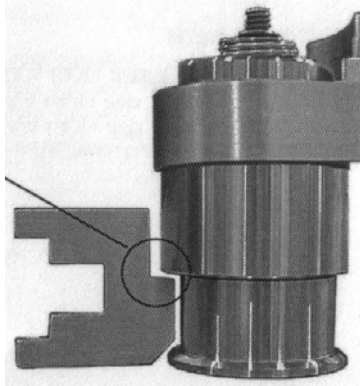

- With one hand apply a light down pressure to the main chassis while holding the suspension housing.
- Rotate the spring counter-clockwise by very small increments until the suspension housing lightly rests against the step on the gauge.

**Make the Suspension Housing Sit Lower**

If the suspension housing is sitting low as on this picture.

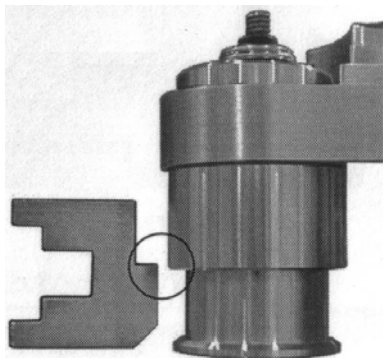

- Gently raise the suspension housing with one hand.
- Using needle pliers, insert the tip of the pliers near the end of the spring and hold it firmly.
- While holding the spring to prevent it from turning, rotate by very small increments the suspension housing, counter-clockwise. This will move the spring further out of the spring calibration sleeve thus making the suspension housing sit higher.

**Note:** Do not allow the pliers to contact the aluminium parts since this could damage the clear lacquer finish.

**Important!** In the unlikely event that your Oracle suspension system may need to be completely re calibrated please refer to the caution on the preceding page.

- When all suspension towers are fine tuned, install the suspension covers.



## CONNECTION PROCEDURE

---

The analogue and/or digital connections

### CD 2000 Transport

Your Oracle CD transport is equipped with three digital outputs:

- BNC, (75 Ohms) output of 0,5 Volt peak to peak
- XLR, AES/EBU (110 Ohms), balanced output of 4 Volts peak to peak
- Optical, Hewlett Packard (ST, AT&T – glass) – Hp-HFBR 1412

Use the designed output to transfer the signal to your Digital to Analog converter.

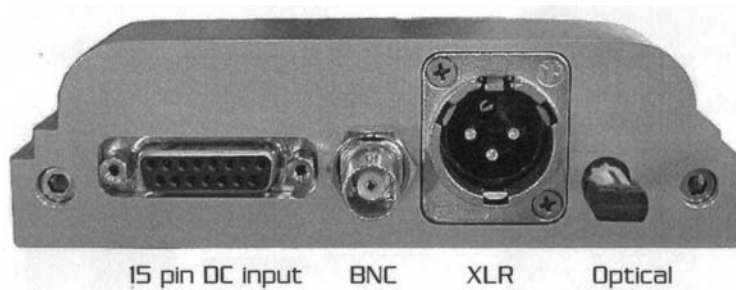

**Note:** We strongly suggest the use of the best possible Digital/Optical Interconnect cable available, your dealer will help you make the right choice.

### CD 2500 MK II Player

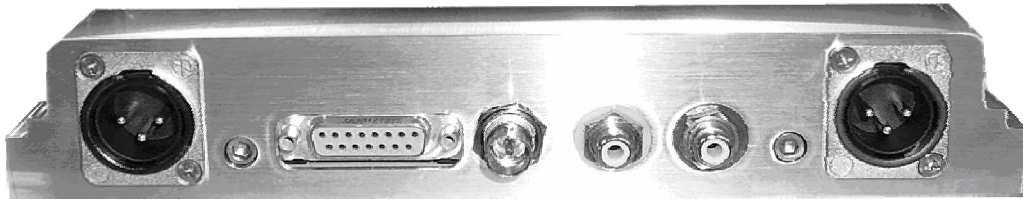

Oracle Audio created a proprietary 2 IC chip circuit implementation of the balanced technology, resulting in excellent audio performance. The fully-balanced technology offers a more open, transparent sound with improved dynamics. The Oracle Audio balanced circuitry greatly reduces transient demand on the component power supply, further improving signal integrity and noise immunity.

Balanced audio interconnects utilize two conductors, while standard RCA audio interconnects use only a single "unbalanced" conductor. This enhanced design gives balanced audio interconnects the power to provide greater resistance against sources of noise (RF, EMI, etc.). The result is a more pure signal transfer, especially in longer-run applications. The industry standard NEUTRIK

XLR connection is utilized due to their robust design and high performance. All internal wiring consists of twisted shielded wire.

Your Oracle CD Player is equipped with:

- BNC, output of 0,5 Volts peak to peak @ 75 Ohms
- RCA analog output
- XLR balanced analog outputs
- Impedance < 100 Ohms
- Recommended impedance load 50 kOhms (Minimum 5 kOhms)
- Maximum effective output level, 2,4 Volts
- Digital to Analogue converter type, Delta Sigma
- Resolution 24 Bits

You now have a choice of analog connections. You might even consider running both at the same time.

To utilize the analog RCA capabilities, connect your pair of RCA terminated interconnect cables from the rear of the player to your preamplifier or integrated amplifier (CD INPUT).

To utilize the analog balanced XLR connections, connect your pair of XLR terminated interconnect cables from the rear of the player to your preamplifier or integrated amplifier's XLR inputs.

#### **Connection to the Pre-Amplifier, CD input**

- Connect your pair of RCA terminated Analogue Interconnect cables from the rear of the player to your pre-amplifier Digital input (CD input).

**Note:** It is not necessary to use digital output unless connecting to a separate stand alone DAC.

**Note:** We strongly suggest the use of the best possible Analogue Interconnect

#### **Simultaneous Connection of an External Digital to Analogue Converter**

It is possible to simultaneously use the BNC (75 Ohms) Digital output to compare the players internal Digital/Analogue converter, with that of an external (stand alone) D/A converter.

- Plug your digital/optical interconnect to the rear of the player and connect it to your stand alone D/A converter.
- Connect the **Analogue outputs** to an "Auxiliary" input at the rear of your pre-amplifier.
- Balance the volume between the two D/A converters through the external converter volume control...should this facility be available.
- Switch from "**CD**" to "**Auxiliary**" so as to compare the two options.

**Warning!** Lower the volume of the pre-amplifier as there could be a major difference in gain, this could cause damage to your loudspeakers.

## POWER SUPPLY CONNECTION

---

- Connect the 15 pin DC signal cable to the rear of the CD turntable and secure it with the two locking thumbs screws.
- Connect the other end to the power supply and secure it as above.

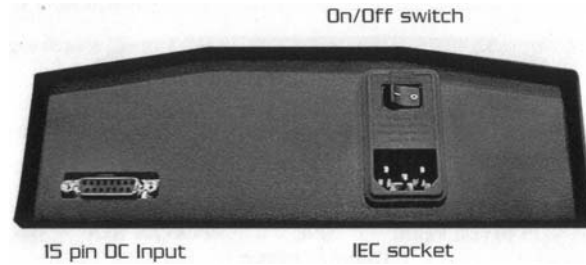

- Plug the AC power cord to the IEC socket at the power supply end, and the other end to the line voltage wall socket.
- Turn the power supply "ON", indicated by the line ( — ) on the rocker switch above the IEC socket, the red "L.E.D." at the front of the power supply will now light up. The "OFF" position is indicated by ( 0 ) on the rocker switch.

### Important Warning!

**CLASS 1 Laser Product.** It is essential that the protective top cover be installed and remains in place until the "No Disc" message appears in the CD display. This also applies should the unit be switched off during a listening session, **NEVER remove** this cover until the "No Disc" or the disc information message appears or re-appears after a new switch-on.



## THE MAGNETIC DISC CLAMP

---

### Operation

- Place the compact disc on your Oracle CD turntable.
- Install the magnetic disc clamp

### To Remove the Magnetic Disc Clamp (option 1)

- Lift the compact disc by holding it from the periphery with the magnetic disc clamp installed.



### To Remove the Magnetic Disc Clamp (option 2)

- Lift the magnetic disc clamp straight up. The compact disc will follow because of the adhesion of the Urethane vibration damping trap to the compact disc surface.



**Caution!** Since the adhesion will diminish as the Urethane picks up dust, it is important to place your hand under the compact disc to prevent it from falling. Please read the recommended maintenance procedure below.

- Peel the disc from the clamp, this will break the close seal between the Urethane vibration damping trap and the compact disc.

### Maintenance

Your Oracle player is equipped with a very efficient magnetic clamp. One of the key features of this clamp is the proprietary Urethane compound ring that acts as a vibration damping trap. To obtain optimal performance, keep the surface of the Urethane vibration damping trap clean at all times using your Brilliance cleaner or denatured alcohol (mentholated spirits).

**To extend the cleaning cycle to a maximum**, we recommended not setting the magnetic disc clamp with the Urethane facing down as dust would very quickly reduce the adhesion to the compact disc, thus lowering the vibration damping trap efficiency.

## SAFE OPERATING INSTRUCTIONS

---

### Please Follow these Important Safety Tips for The Safe Operation of your CD Player

The main Power On/Off switch for your CD Player/Drive is located on the rear of the power supply.

**Note** Do not activate this switch until you have read the instructions below.

1. Before switching on your CD Player/Drive it is essential that the aluminium top cover be correctly installed and remain in place until the CD display indicates the **"No Disc"** message.
2. To start playing a CD: remove the aluminium top cover; select the CD you wish to play and place it on the CD turntable. Install the magnetic clamp and replace the top cover.
3. Press the **Reset** button and wait for the disc information to appear in the main CD display. The information will show the number of tracks on the CD and the total playing time.
4. Press **"Play"** and adjust the volume control on your pre-amplifier, sit back, and *ENJOY PURE MUSIC!*
5. **To change a CD**, press **"Stop"**, the CD display will again show the disc information. Remove the aluminium top cover, lift your CD using one of the methods described earlier. Gently peel the clamp from the CD. Select your next CD and place it on the CD turntable as described above. Having placed the disc on the turntable, the display will still show the details of the previous CD player until you press the **Reset** button, only then will the new disc information be displayed.

**Note:** These instructions may seem extremely basic, but they must be followed exactly to ensure safe operation of this product!

### Display Keyboard Function Selector

The display module is equipped with five selector buttons.

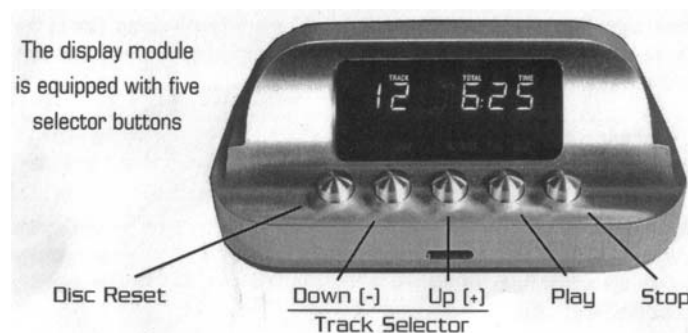

- Place a compact disc over the centering device of your CD turntable.
- Position the **magnetic disc clamp** over the centering device and **make sure it is well seated**.
- Very carefully seat the **aluminium top cover** over the compact disc in its specially machined recess and position it so **the two finger slots** match the ones on the player main chassis. The slightly curved section of the finger slots should be facing **the front of the unit**.

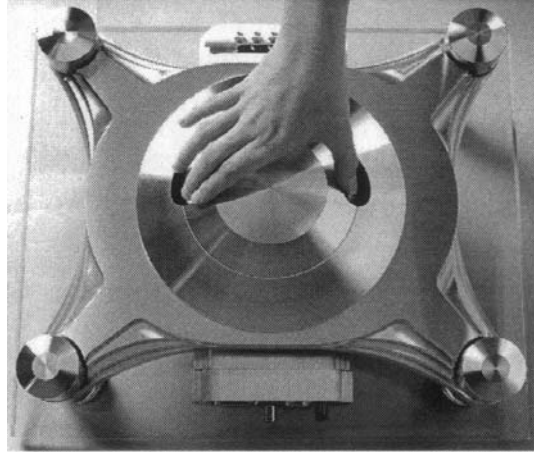

The performance of the Oracle CD turntable is significantly improved by using the aluminium top cover whenever the player is in use. It provides a darker environment for the laser diode to more accurately pick up signals from the spinning compact disc.

#### **To Play a Compact Disc**

- Press the “Disc Reset” function selector to initialize the selected disc. **This operation must be repeated every time a different compact disc is used.**
- Select the track to be played by pressing the “Up” and “Down” function track selector.
- Press “Play” and adjust the volume control on your pre-amplifier, sit back, and *ENJOY PURE MUSIC!*

#### **To Play a Different Compact Disc**

- Press the “Stop” function selector and repeat the “To Play a Compact Disc” procedure.
- Remove the aluminium top cover and put it to one side.

**Important!** Press the “Disc Reset” function selector every time a new compact disc is placed on the CD turntable, so it can be properly initialized.

## REMOTE CONTROL OPERATION

---

For your convenience and to increase ease of use, your new Oracle CD Player/Drive is supplied with an Infra-red remote control facility. To enable you to reap the benefit of this facility, please spend a few minutes reading these simple instructions.

Beginning at the top, or front of the handset the various buttons (function keys) will be described on the left of the page. What the button does and how to do it is described on the right of the page.

### FUNCTION KEY

### WHAT IT DOES & HOW TO DO IT

#### *Red Button (STBY)*

This is the Standby button and this allows the display screen to be turned off as if the unit was out of service. Whilst the player looks as if it is switched off, the optimum operating temperature is maintained. PRESS the **STBY** button once and the display goes out. PRESS the **STBY** again and this will have a similar effect as pressing the "Disc Reset" on the display keyboard function selector to initialize the selected disc. If the unit was in a Standby mode after using the **STBY** button, it must be pressed again so the player can resume the operational mode.

#### *Numeric Buttons (1-0)*

These buttons relate to the track numbers on your CD, and run from 1 through 9, the 0 button becomes 10 by pressing first 1 then 0. The player is able to play, merely by pressing a combination of two buttons any track on a CD that may contain anything up to 99 tracks.

#### *Scan Button (SCAN)*

This button permits you to **SCAN** a CD to find a particular track. PRESS this button once and it plays the first few seconds of every track in numeric order. Once you have heard the track you want, PRESS the button again and your chosen track will play from the beginning.

#### *Programme Button (PROG)*

This button allows you to select various tracks of a CD and play them in your chosen order. To use this function you first select a track number using the numeric buttons, having selected the track number PRESS **PROG**. Move on using the numeric buttons to your next selection and again PRESS **PROG**. Repeat this operation until you have programmed as many or as few tracks as you want. The track selection will play in the order in which you have entered the track numbers. The **PROG** function is cancelled by pressing **STOP**.

#### *Time Button (TIME)*

This button allows you to view various **TIME** options. The default setting will indicate the number of tracks and the total running time of the disc is displayed. PRESS **PLAY** and the elapsed time of the track playing will show. PRESS **TIME** once and the elapsed running time of the disc will show. PRESS **TIME** again and the remaining running time of the disc will show.

#### *Fast Button (FAST)*

This button is located next to both, the track search forward ►► and track search back ◀◀ buttons. PRESS the **FAST** button to double the search speed before pressing the ►► and ◀◀

buttons. The sound heard in order to find a particular section of track will be more difficult to identify using the **FAST** mode.

*Search Button (◀◀ ▶▶)* This function allows you to search forward or backwards through a track, or the complete CD at approximately 10 times normal speed. It is possible to hear the track/CD whilst doing this enabling you to find a specific part of a track/CD. PRESS ◀◀ and the search runs back from where you are. PRESS ▶▶ and the search runs forward from where you are.

*A/B Button (A / B)* This button allows you to repeat a **section** of a track or the CD. To do this, listen for the starting point of the section you want to repeat and PRESS the **A / B** button once. Let the section run to where you want the repeated section to end, then PRESS the **A / B** button once more. The selected section will now continue to repeat just that section until you cancel the command by pressing **STOP**.

*Shuffle Button (SHUF)* This command causes the track playing order to be played non numerically ascending. Instead of the tracks being played from 1 through to say 10, it will play the tracks in a random order. The track play order cannot be determined by the user when using this function. This function must be chosen before the **PLAY** button is pressed. The disc information will be displayed on the main display screen. PRESS **SHUF** and the random track play order will be displayed along the bottom of the main display screen. PRESS **PLAY** and the randomly selected order will start playing.

*Previous Track (| ◀)* This button has two functions, and is marked | ◀. PRESS once and the track being played will start playing from the beginning again. PRESS | ◀ twice quickly and the previous track on the CD will play from the beginning.

*Next Track (▶ |)* This button only has function, and is marked ▶ |. PRESS this button once and the next track on the CD will begin playing. Each time you press this button, the next track on the CD will begin to play in the normal ascending numeric order, or the next programmed selection if you have used the **PROG** option. If in the **SHUF** mode the next randomly selected track will begin to play.

*Repeat (REP)* This function permits continual repeat playing of the track being played by pressing the **REP** button once. PRESS the **REP** button twice and the **WHOLE** disc will be repeated until the **REP** button is pressed again cancelling the repeat function. The **REP** function can also be used if **PROG** or **SHUF** modes have been selected, and works in exactly the same way. PRESS once and the track being played will repeat, PRESS twice and **ALL** the programmed selections **PROG**, or the random play order **SHUF**, will be repeated. PRESS **REP** again and the selection will play the **REP** function was cancelled.

*Pause (PAUSE)* This function suspends the playing of the CD at the exact point that the **PAUSE** button was pressed. This mutes the sound



completely. PRESS **PAUSE** again and play resumes from the exact point it was originally suspended.

*Stop (STOP)*

This function stops the CD turntable from spinning and the laser from reading the digital information on the disc. It also cancels all programmed functions and enables the current disc to be removed. The CD turntable is now ready to accept another disc, or to be switched off at the end of the current listening session.

*Play (PLAY)*

The **PLAY** function is used to start a new listening programme. When a CD is placed on the turntable the **PLAY** function will not operate until one of the two following function is activated:

- a) The **RESET** button on the CD Player/Drive has been pressed.
- b) The **STBY** button on the remote control handset is pressed twice.

This starts the turntable spinning and the disc information is read by the laser. The disc information will then appear on the main display screen. Once the disc information is displayed, it is possible to play the CD by pressing **PLAY** button on the remote control handset.



## ROUTINE CLEANING OF THE LASER LENS

---

**Warning!** Extreme care is required when carrying out this procedure, the drive and lens mechanisms are extremely delicate.

### Routine Cleaning

Cleanliness is essential in order to maintain optimum performance. Routine cleaning of the laser lens should be carried out weekly in the following way:

1. Turn off the power to the CD Player using the switch on the rear of the power supply.
2. Unplug the supply power cord from the wall socket.
3. Remove the aluminium top cover and the magnetic disc clamp.
4. Using a clean cotton bud/Q-tip damped with denatured alcohol gently wipe the laser lens.



**Warning!** Do not allow to drip into the mechanism.

### Important Warning!

**CLASS 1 Laser Product.** It is essential that the protective top cover be installed and remains in place until the "No Disc" message appears in the CD display. This also applies should the unit be switched off during a listening session, **NEVER remove** this cover until the "No Disc" or the disc information message appears or re-appears after a new switch-on.

## FUSE REPLACEMENT

---

If the power supply is connected to the line source and the switch is in the “ON” position the red “L.E.D.” locate at the front of the unit will glow. If it does not glow make sure the line signal coming from the wall outlet is operational. If everything is normal, follow the procedure below to proceed to the replacement of the line input fuse.

- Switch the power supply to the “OFF” position.
- Unplug the AC power cord at the power supply end.
- Use a flat blade screw driver and insert it in the slot at the top of the IEC socket to open the flap as shown on the picture.
- Use the same flat blade screw driver to gently extract the fuse holder.
- Using a continuity tester check the fuse for continuity. Continuity means “good fuse”. No continuity means “fuse no good”.
- Make sure to reinsert the fuse holder in the same direction as the arrow inside the cover.

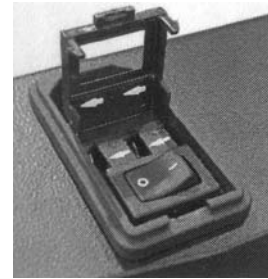
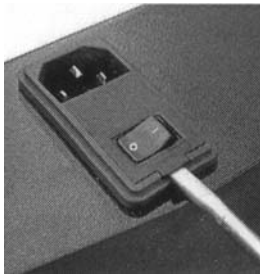

**Note:** There are 2 fuses inside the IEC socket, the one under the ( 0 ) is the one in the signal path. The fuse under the “( — )” is a spare.

- Close the flap until it snaps in a fully closed position.
- Plug the AC power cord at the power supply end.
- Switch the power supply to the “ON” position.

### Fuse Types

CD Drive (Fuse type)

100-120V – Right: GMD 200mA

220-240V – Right: GMD 200mA

CD Player (Fuse type)

100-120V – Left: GMD 200mA Right: GMD 630mA

220-240V – Left: GMD 200mA Right: GMD 630mA





**\* GMD Fuse Type only**

### Important Note!

If the fuse keeps blowing, it might be an indication of a defective power supply unit, please contact your dealer for advice. Do not use a different value fuse than recommended.



## Oracle Audio CD 2000/2500 MK II Specifications

Configuration	Solid State
Chassis	Hand Brushed Aluminum Chassis with a Clear Laquer Coating
CD Laser Mechanism	Philips CDPPro II
CD 2000 Output Interfaces	BNC SP/DIF Digital Audio Signal, XLR AES/EBU, ST (AT&T) Optical Audio Signal.
 <p>Oracle Audio CD 2000 CD Transport Interface</p>	<p>Single Ended SP/DIF, Digital Audio Signal Format: BNC Load Impedance: 75 Ohms Output Impedance: 75 Ohms Output Level: 0.5 Volts, peak to peak @ 75 Ohms</p> <p>AES/EBU, Digital Audio Signal Format: XLR Load Impedance: 110 Ohms Output Impedance: 110 Ohms Output Level: 4 Volts, peak to peak @ 110 Ohms</p> <p>ST (AT&amp;T) Optical Audio Signal Standard: ST Optical Interface (glass optical) Device: HFBR 1412, High-bandwidth Wave Length: 820nm</p>
CD 2500 MK II Output Interfaces	(1) Pair RCA Analog, BNC SP/DIF Digital Audio Signal (1) Pair XLR Analog balanced output
 <p>Oracle Audio CD 2500 MK II CD Player Interface</p>	<p>Single Ended SP/DIF, Digital Audio Signal Format: BNC Load Impedance: 75 Ohms Output Impedance: 75 Ohms Output Level: 0.5 Volts, peak to peak @ 75 Ohms</p> <p>RCA (Analog Audio Signal) Format: Cardas Rhodium plated RCA connectors 5k Ohms minimum, 50k Ohms Maximum Output Impedance: Lower than 100 Ohms Output Level: 2.4 volts effectively Conversion: Crystal CSA4390, 24BIT Type: Delta-Sigma Signal to noise ratio: 115 dB Dynamic Range: 106 dB Oversampling: 128X</p>
Power Consumption	CD 2000 Transport: 13W CD 2500 MK II Player: 18W
AC Power Requirements	100 / 117 / 220 (230) / 240V, 50Hz or 60Hz
Removable Power Cord	Included
Remote Control	Included (Full Function Hand Brushed Aluminum with a Clear Laquer Coating)
Outboard Power Supply	Included
Warranty	2 Years from Purchase Date
Overall Dimensions (WHD)	425mm x 150mm x 363mm, 17in x 6in x 14.5in
Weight	16 Kg, 35.2 lbs



*The Fine Art of Playing Music*

Oracle Audio Technologies • Canada  
www.oracle-audio.com • info@oracle-audio.com • Phone 819-864-0480 • FAX 819-864-9641

**We are confident your new Oracle product will give you  
many years of satisfaction**

**You are now ready for the real and only purpose of all this...  
to sit down and relax, and to enjoy the Fine Art of Playing Music**

**Oracle Audio Technologies Inc  
6136 Boulevard Bertrand Fabi, Suite 101  
Sherbrooke, Quebec, Canada  
J1N 2P3**

**Phone: 819-864-0480 Fax: 819-864-9641  
e-mail: [info@oracle-audio.com](mailto:info@oracle-audio.com)  
[www.oracle-audio.com](http://www.oracle-audio.com)**