

Rim Owners Manual

Adult Assembly Required.

This manual, accompanied by sales receipt, should be saved and kept on hand as a convenient reference, as it contains important information about your model.

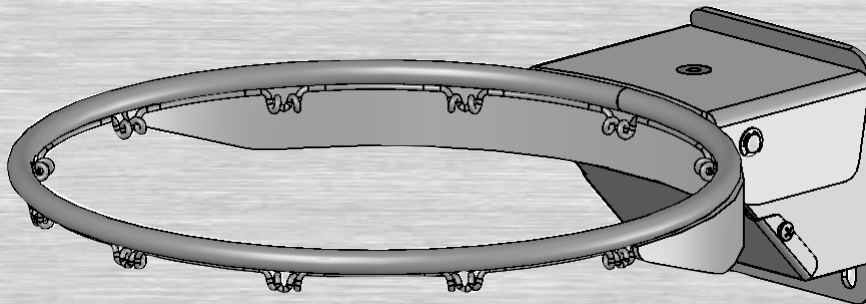

Model Number:



! WARNING!

READ AND UNDERSTAND
OPERATOR'S MANUAL
BEFORE USING THIS UNIT.

FAILURE TO FOLLOW
OPERATING INSTRUCTIONS
COULD RESULT IN INJURY
OR DAMAGE TO PROPERTY.

Customer Service Center
• 200 American Avenue • Jefferson, IA 50129
www.spalding.com • www.basketballproducts.com • www.hydra-rib.com

Assemblage exclusivement réservé à un adulte.

Zusammenbau nur durch Erwachsene ALLE Verpackungsmaterialien sofort wegwerfen.

Il montaggio va eseguito da persone adulte.

Anneau Guide d'utilisation

Service clientèle

• N53 W24700 South Corporate Circle • Sussex, WI 53089 • É.-U.

Ring Gebrauchsanleitung

Kundendienstzentrale

• N53 W24700 South Corporate Circle • Sussex, WI 53089 • U.S.A.

Aro Manual de usuario

Centro de Servicio al Cliente

• N53 W24700 South Corporate Circle • Sussex, WI 53089 • EE.UU.

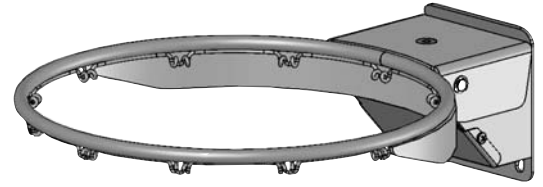

Ce manuel, accompagné du justificatif d'achat, devra être conservé pour référence ultérieure, dans la mesure où il contient des informations importantes sur votre modèle.

Diese Anleitung sollte zusammen mit dem Kaufbeleg griffbereit aufbewahrt werden, da sie wichtige Informationen über Ihr Modell enthält.

Il presente manuale, accompagnato dallo scontrino, deve essere conservato e tenuto a portata di mano come documento di facile consultazione, in quanto contiene informazioni importanti su questo modello.

<p>Model Number: Numéro de référence du modèle: Modellnummer: Número de modelo:</p> <input type="text"/>



**AVERTISSEMENT!
WARNUNG!
¡ADVERTENCIA!**



**LISEZ LE MODE D'EMPLOI AVANT
D'UTILISER CE SYSTÈME.**

**SOUS PEINE D'ENCOURIR DES
BLESSURES OU DES DÉGÂTS
MATÉRIELS.**

**DAS BENUTZERHANDBUCH VOR
GEBRAUCH DIESES PRODUKTS
SORGFÄLTIG DURCHLESEN.**

**EIN MISSACHTEN DIESER
BETRIEBSANLEITUNG KANN
VERLETZUNGEN ODER SACHSCHÄDEN
ZUR FOLGE HABEN.**

**LEA Y ENTIENDA EL MANUAL DEL
OPERADOR ANTES DE USAR ESTA
UNIDAD.**

**SI NO SE SIGUEN LAS INSTRUCCIONES
DE OPERACIÓN SE PODRÍA
OCASIONAR UNA LESIÓN O DAÑOS A
LA PROPIEDAD.**

Numéro vert du Service clientèle - États-Unis : 1-800-558-5234, Canada : 1-800-2284-8339,
Europe : 00 800 555 85234 (Suède : 009 555 85234), Australie : 1-800-632 7921 Adresse Internet : <http://www.huffysports.com>

Gebührenfreie Telefonnummer für die USA: 1-800-558-5234, für Kanada: 1-800-284-8339, für Europa: 00 800 555 85234 (Schweden: 009 555 85234), für Australien: 1-800-632 7921 Internet-Adresse: <http://www.huffysports.com>

Número telefónico sin costo del Departamento de Servicio al Cliente en EE.UU.: 1-800-558-5234,
Para Canadá: 1-800-284-8339, Para Europa: 00 800 555 85234 (Suecia: 009 555 85234), Para Australia: 1-800-632 7921 Dirección en
Internet: <http://www.huffysports.com>

REQUIRED TOOLS AND MATERIALS:



- (2) Stepladders 8 ft. (2.4 m)



- (1) Allen Wrench (5/16")

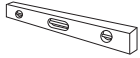

- (1) Carpenter's Level

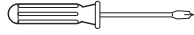

- (1) Phillips-Head Screwdriver

- (2 each) Wrenches and/or Socket Wrenches and Sockets (Deep-Well Sockets are Recommended).



9/16" 3/4"

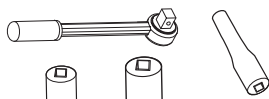

9/16" 3/4"

OUTILS ET MATÉRIEL REQUIS:



- (2) • Échelle de 2,4 m



- (1) Clé Allen (5/16")



- (1) Niveau à bulle



- (1) un tournevis cruciforme

- Deux clés et/ou clés à douilles et deux douilles (douilles longues recommandées).

- Une extension est recommandée.



9/16" 3/4"

ET/OU

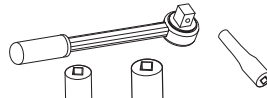

9/16" 3/4"

BENÖTIGTE WERKZEUGE UND MATERIALIEN:



- (2) Stufenleiter, 2,4 m (8 Fuß)



- (1) Inbusschlüssel (5/16")

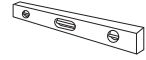

- (1) Wasserwaage

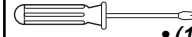

- (1) ein Kreuzschlitzschraubenzieher

- (je 2) Schrauben - und/oder Steckschlüssel (tiefe Einsätze empfohlen).

- Verlängerung wird empfohlen



9/16" 3/4"

UND/ODER

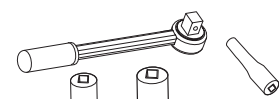

9/16" 3/4"

HERRAMIENTAS Y MATERIALES REQUERIDOS:



- (2) Escalera de mano de 8 pies (2.4 m)



- (1) Llave Allen (5/16")

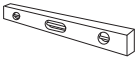

- (1) Nivel de carpintero

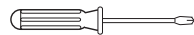

- (1) un destornillador Phillips

- (2 de cada una) llaves de tuercas y/o llaves de tuercas de boca tubular y casquillos (se recomiendan casquillos profundos).

- Se recomienda una extensión



9/16" 3/4"

Y/O

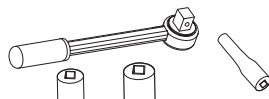

9/16" 3/4"

- Manguera de jardín o arena

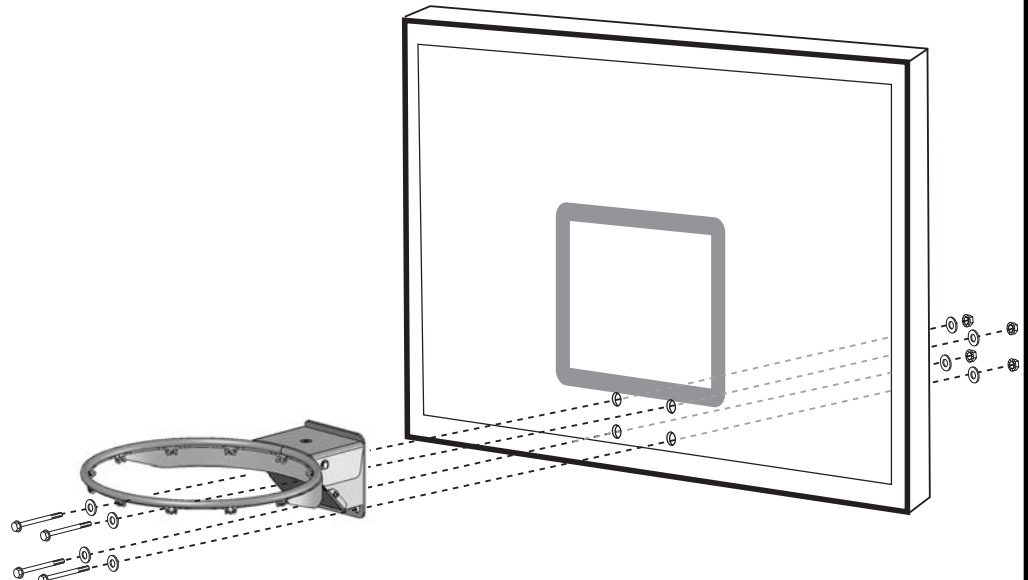
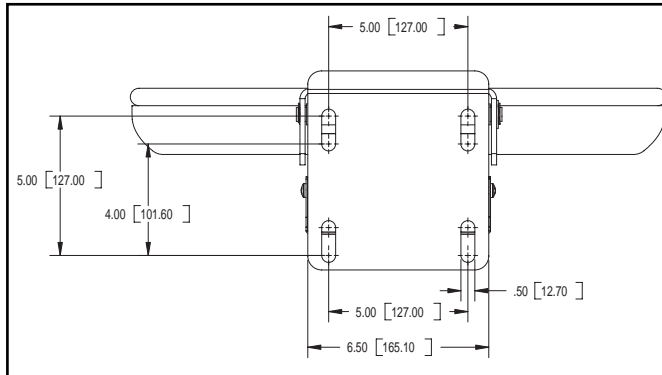

TO LEVEL RIM
POUR INSTALLER L'ANNEAU
RING ANPASSEN
PARA NIVELAR EL ARO

- A. Remove the rim cover from the rim.
 - B. Make adjustments as shown below.
 Tightening the nut which preloads the spring increases the rim's resistance to movement - the more the preload, the more force will be required to move the rim downward.
- A. Retirez l'emballage du panneau.
 - B. Procédez aux ajustements comme indiqué ci-dessous.
 En serrant le boulon de précharge du ressort, la résistance au mouvement du panneau augmente – plus il y a de précharge, plus il faudra de force pour déplacer le panneau vers le bas.
- A. Nehmen Sie den Ring aus der Verpackung.
 - B. Nehmen Sie die Einstellungen, wie unten gezeigt, vor.
 Durch Anziehen der Mutter, welche die Feder vorspannt, wird der Bewegungswiderstand des Ringes erhöht. Je mehr Vorspannung, desto mehr Kraft wird benötigt, um den Ring nach unten zu ziehen.
- A. Quite la cubierta del aro.
 - B. Haga los ajustes que se muestran abajo.
 Al apretar la tuerca que precarga el resorte se aumenta la resistencia al movimiento del aro: cuanto mayor sea la precarga, mayor fuerza se requerirá para mover el aro hacia abajo

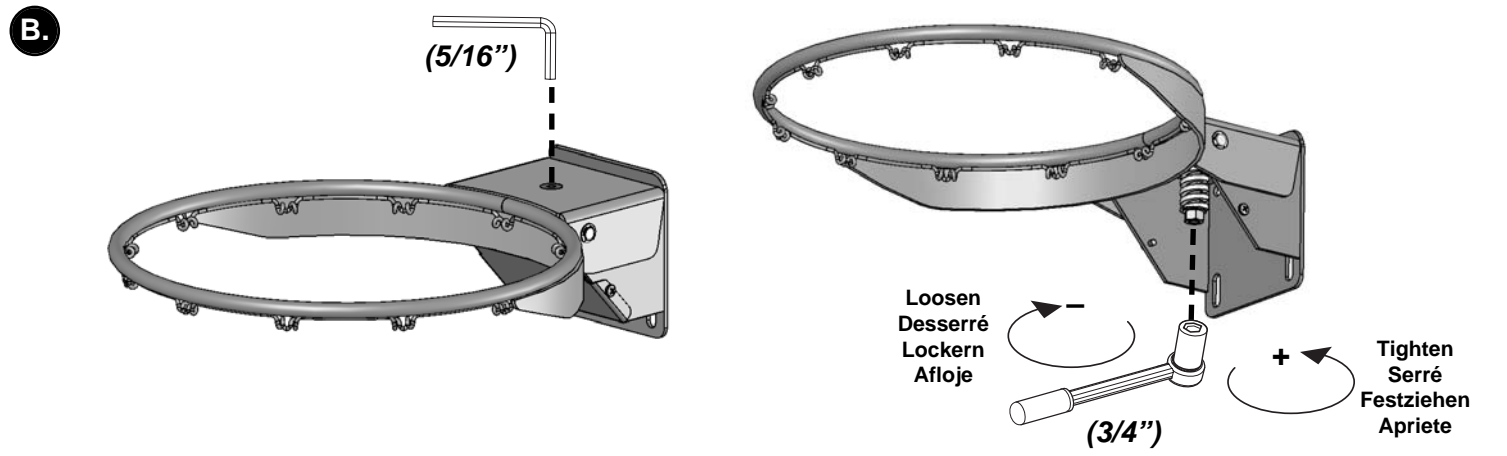
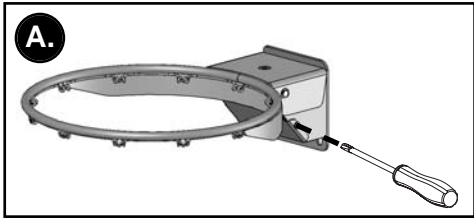

INSTALL NET
INSTALLATION DU PANIER
NETZ ANBRINGEN
INSTALE LA RED

