

NOTE:
Please read all instructions
carefully before using this
product

Table of Contents

Safety Notice

Hardware Identifier

Assembly Instruction

Parts List

Warranty

Ordering Parts

Model
MD-8850

Retain This
Manual for
Reference

07-27-09

OWNER'S
MANUAL

IMPEX

MARCY[®] DIAMOND ELITE

OLYMPIC CAGE

MD-8850

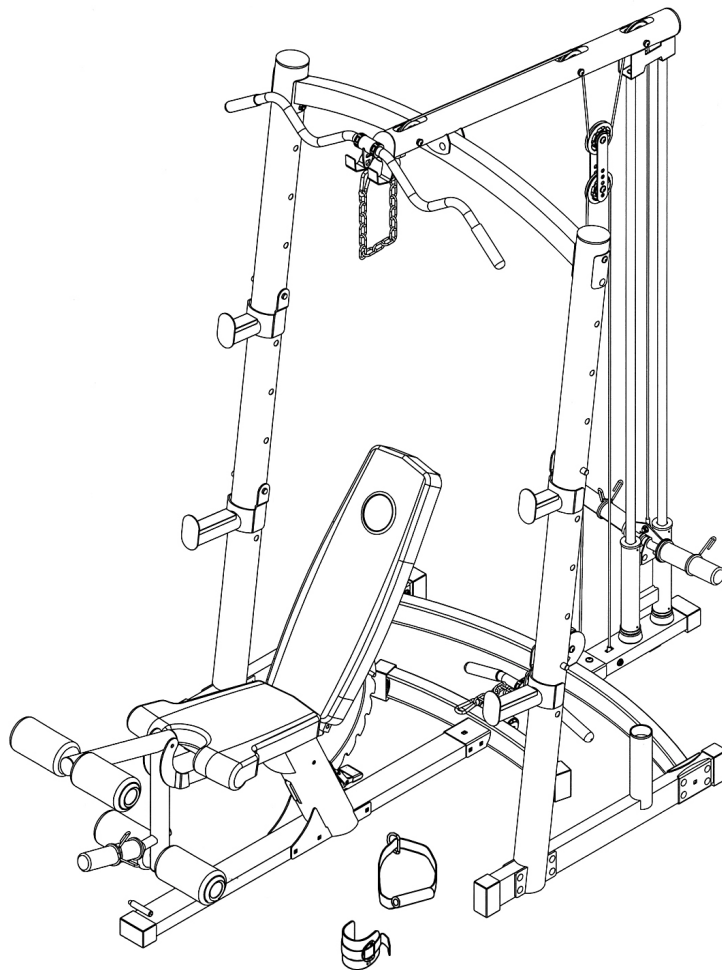

IMPEX[®] INC.

14777 DON JULIAN RD., CITY OF INDUSTRY, CA 91746

Tel: (800) 999-8899 Fax: (626) 961-9966

www.impex-fitness.com

info@impex-fitness.com

TABLE OF CONTENTS

BEFORE YOU BEGIN.....	1
IMPORTANT SAFETY NOTICES.....	2
CAGE HARDWARE PACK.....	4
CAGE ASSEMBLY INSTRUCTIONS.....	6
CAGE EXPLODED DIAGRAM.....	14
CAGE PARTS LIST.....	15
BENCH HARDWARE PACK.....	16
BENCH ASSEMBLY INSTRUCTIONS.....	18
BENCH EXPLODED DIAGRAM.....	23
BENCH PARTS LIST.....	24
WARRANTY.....	25
ORDERING PARTS.....	25

BEFORE YOU BEGIN

Thank you for selecting the MARCY DIAMOND ELITE MD-8850 Olympic Cage by IMPEX® INC. For your safety and benefit, read this manual carefully before using the machine. As a manufacturer, we are committed to provide you complete customer satisfaction. If you have any questions, or find there are missing or damaged parts, we guarantee you complete satisfaction through direct assistance from our factory. To avoid unnecessary delays, *please call our TOLL-FREE customer service number.* Our Customer Service Agents will provide immediate assistance to you.

Toll-Free Customer Service Number
1-800-999-8899
Mon. - Fri. 9 a.m. - 5 p.m. PST
www.impex-fitness.com
info@impex-fitness.com

IMPORTANT SAFETY NOTICE

PRECAUTIONS

This exercise machine is built for optimum safety. However, certain precautions apply whenever you operate a piece of exercise equipment. Be sure to read the entire manual before you assemble or operate your machine. In particular, note the following safety precautions:

1. **Keep children and pets away from the machine at all times. DO NOT leave children unattended in the same room with the machine.**
2. Only one person at a time should use the machine.
3. If the user experiences dizziness, nausea, chest pain, or any other abnormal symptoms, STOP the workout at once. CONSULT A PHYSICIAN IMMEDIATELY.
4. Position the machine on a clear, leveled surface. DO NOT use the machine near water or outdoors.
5. Keep hands away from all moving parts.
6. Always wear appropriate workout clothing when exercising. DO NOT wear robes or other clothing that could become caught in the machine. Running or aerobic shoes are also required when using the machine.
7. Use the machine only for its intended use as described in this manual. DO NOT use attachments not recommended by the manufacturer.
8. Do not place any sharp object around the machine.
9. Disabled person should not use the machine without a qualified person or physician in attendance.
10. Before using the machine to exercise, always do stretching exercises to properly warm up.
11. Never operate the machine if the machine is not functioning properly.
12. A spotter is recommended during exercise.

CARE AND MAINTENANCE

1. Lubricate moving parts with WD-40 or light oil periodically.
2. Inspect and tighten all parts before using the machine.
3. The machine can be cleaned using a damp cloth and mild non-abrasive detergent. DO NOT use solvents.
4. Maximum user's weight: 300 lbs.
5. Maximum weights on the Sliding Weight Post: 100 lbs.
6. Maximum weights on Leg Developer: 100 lbs.
7. Maximum weights capacity: 600 lbs.

WARNING: BEFORE BEGINNING ANY EXERCISE PROGRAM, CONSULT YOUR PHYSICIAN. THIS IS ESPECIALLY IMPORTANT FOR INDIVIDUALS OVER THE AGE OF 35 OR PERSONS WITH PRE-EXISTING HEALTH PROBLEMS. READ ALL INSTRUCTIONS BEFORE USING ANY FITNESS EQUIPMENT. IMPEX INC. ASSUMES NO RESPONSIBILITY FOR PERSONAL INJURY OR PROPERTY DAMAGE SUSTAINED BY OR THROUGH THE USE OF THIS PRODUCT.

SAVE THESE INSTRUCTIONS.

WARNING LABEL PLACEMENT

⚠ WARNING
SERIOUS INJURY MAY OCCUR
Do not attempt to exercise or hang from the lat bar while it is placed or stored on the storage hooks

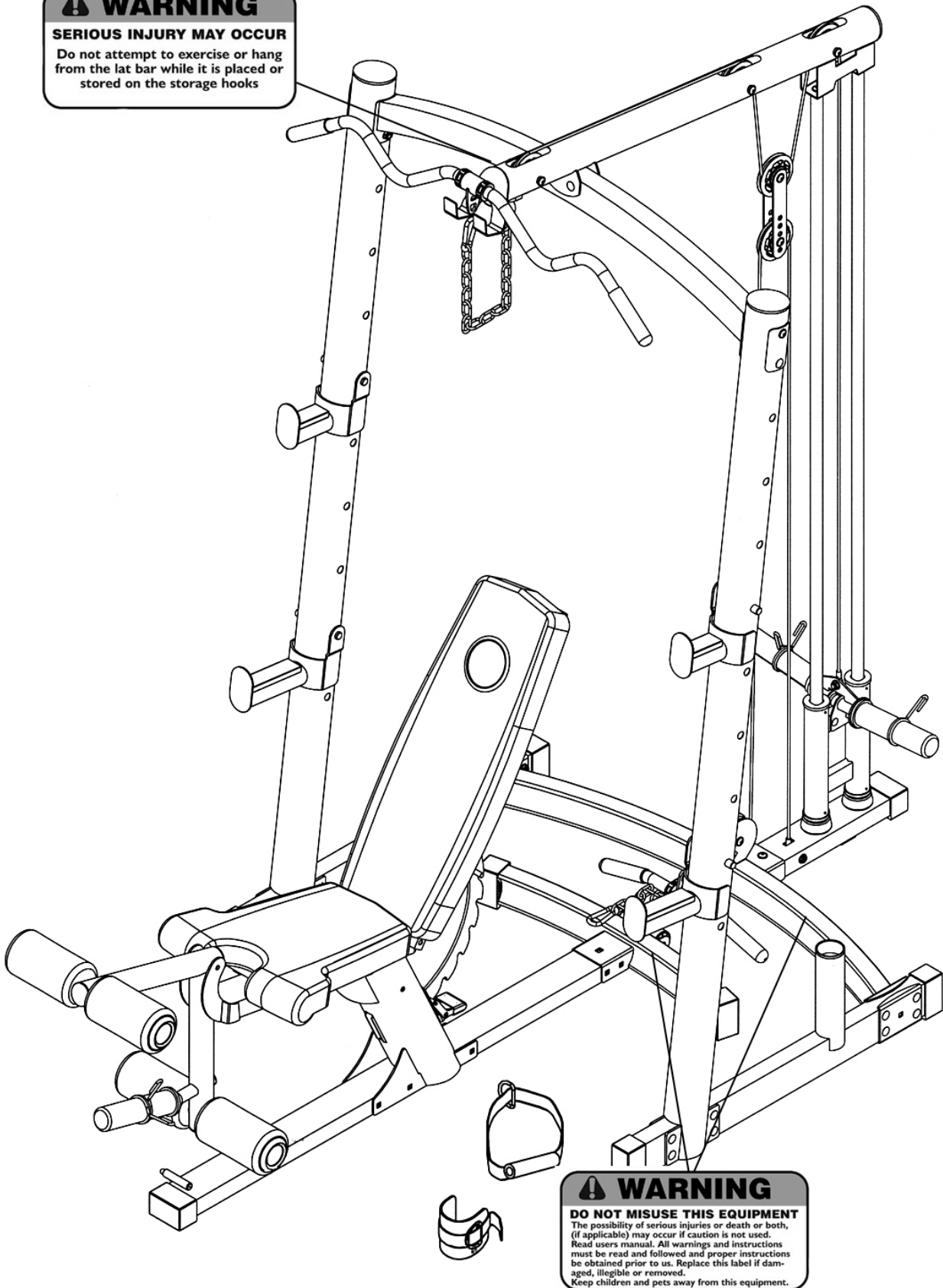

⚠ WARNING
DO NOT MISUSE THIS EQUIPMENT
The possibility of serious injuries or death or both, (if applicable) may occur if caution is not used. Read users manual. All warnings and instructions must be read and followed and proper instructions be obtained prior to us. Replace this label if damaged, illegible or removed. Keep children and pets away from this equipment.

The warning labels shown here have been placed on the Rear Base Frame, Rear Stabilizer, and Upper Frame. If the labels are missing or illegible, please call customer service at 1-800-888-8899 for replacements. Apply the labels in the location shown.

CAGE HARDWARE PACK

NOTE: The following parts are not drawn to scale. Please use your own ruler to measure the size.

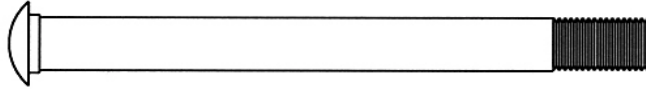

#40 M10 x 4 $\frac{1}{8}$ " Carriage Bolt (Qty 2)

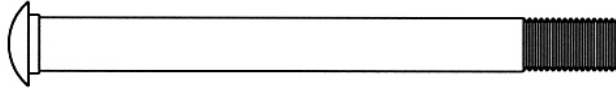

#41 M10 x 4" Carriage Bolt (Qty 1)

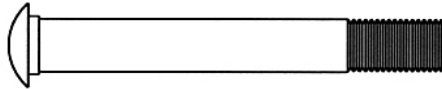

#42 M10 x 2 $\frac{3}{4}$ " Carriage Bolt (Qty 2)

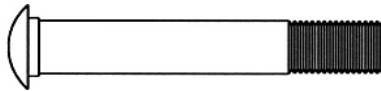

#43 M10 x 2 $\frac{3}{8}$ " Carriage Bolt (Qty 16)

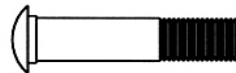

#44 M8 x 1 $\frac{3}{8}$ " Carriage Bolt (Qty 2)

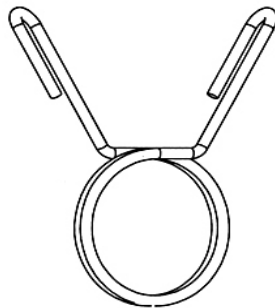

#59 Spring Clip
(Qty 2)

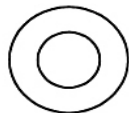

#52 \varnothing $\frac{3}{4}$ " Washer
(Qty 45)

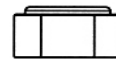

#54 M10 Aircraft Nut
(Qty 29)

mm

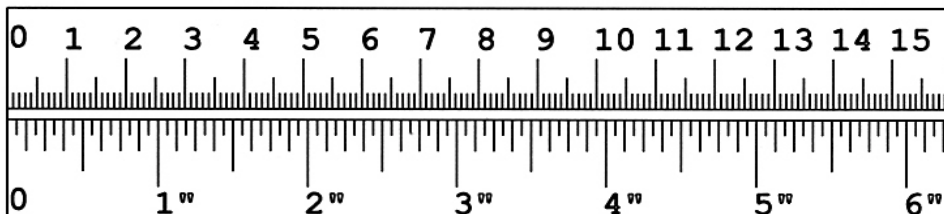

CAGE HARDWARE PACK

NOTE: The following parts are not drawn to scale. Please use your own ruler to measure the size.

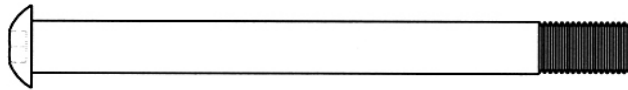

#45 M10 x 4 $\frac{1}{8}$ " Allen Bolt (Qty 2)

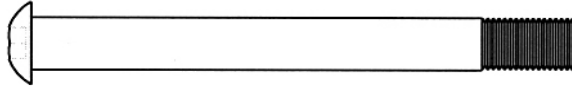

#46 M10 x 3 $\frac{3}{4}$ " Allen Bolt (Qty 3)

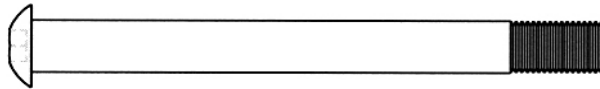

#47 M10 x 4" Allen Bolt (Qty 1)

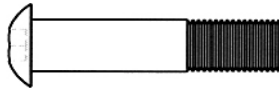

#48 M10 x 1 $\frac{3}{4}$ " Allen Bolt (Qty 3)



#50 M10 x $\frac{3}{4}$ " Allen Bolt (Qty 7)

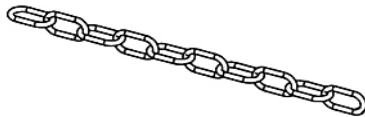

#57 10-link Chain (Qty 1)



#56 Hook (Qty 4)

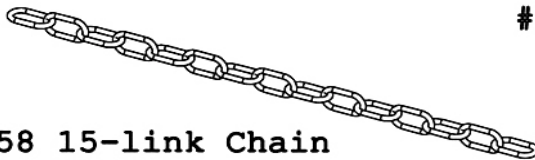

#58 15-link Chain (Qty 1)



#53 $\varnothing \frac{5}{8}$ " Washer (Qty 2)



#55 M8 Aircraft Nut (Qty 2)

mm

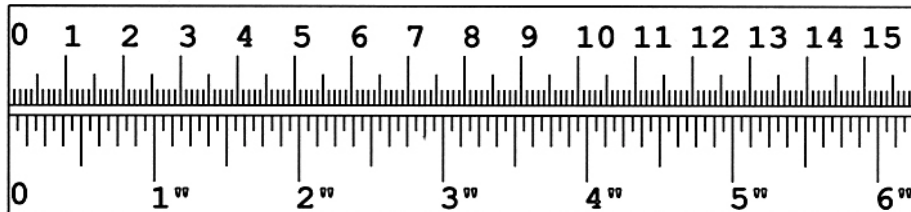

CAGE ASSEMBLY INSTRUCTION

Tools Required for Assembling the Machine: Two Adjustable Wrenches and Allen Wrenches.

NOTE: It is strongly recommended that two or more people assemble this machine to avoid possible injury.

STEP 1 (See Diagram 1)

- A.) Attach a \varnothing 2 1/2" Rubber Bumper (#29) and the Weight Storage Post (#14) to Right Stabilizer (#3). Secure it with one M10 x 3/4" Allen Bolt (#50) and \varnothing 3/4" Washer (#52).
- B.) **Note: Do not tighten the Nuts and Bolts in following steps until instructed to do so.**
- C.) Connect the Right and Left Stabilizer (#2 & #3) by the Rear Base Frame (#4). Secure each end of the Rear Base Frame to each Stabilizer with four M10 x 2 3/8" Carriage Bolts (#43), one 4 3/4" x 3 1/4" Bracket (#17), four \varnothing 3/4" Washers (#52), and four M10 Aircraft Nuts (#54).
- D.) Attach an Upright Beam (#1) onto the Right Stabilizer. Secure it with four M10 x 2 3/8" Carriage Bolts (#43), four \varnothing 3/4" Washers (#52), and four M10 Aircraft Nuts (#54). Repeat the same step to install the other Upright Beam to the Left Stabilizer.
- E.) Attach the Top Beam (#5) to the two Upright Beams. Secure each end of the Top Beam with one M10 x 4 1/8" Allen Bolt (#45) to the upper hole, one M10 x 4 1/8" Carriage Bolt (#40) to the lower hole, one 4" x 2 3/8" Curved Bracket (#16), two \varnothing 3/4" Washers (#52), and one M10 Aircraft Nut (#54).

DIAGRAM 1

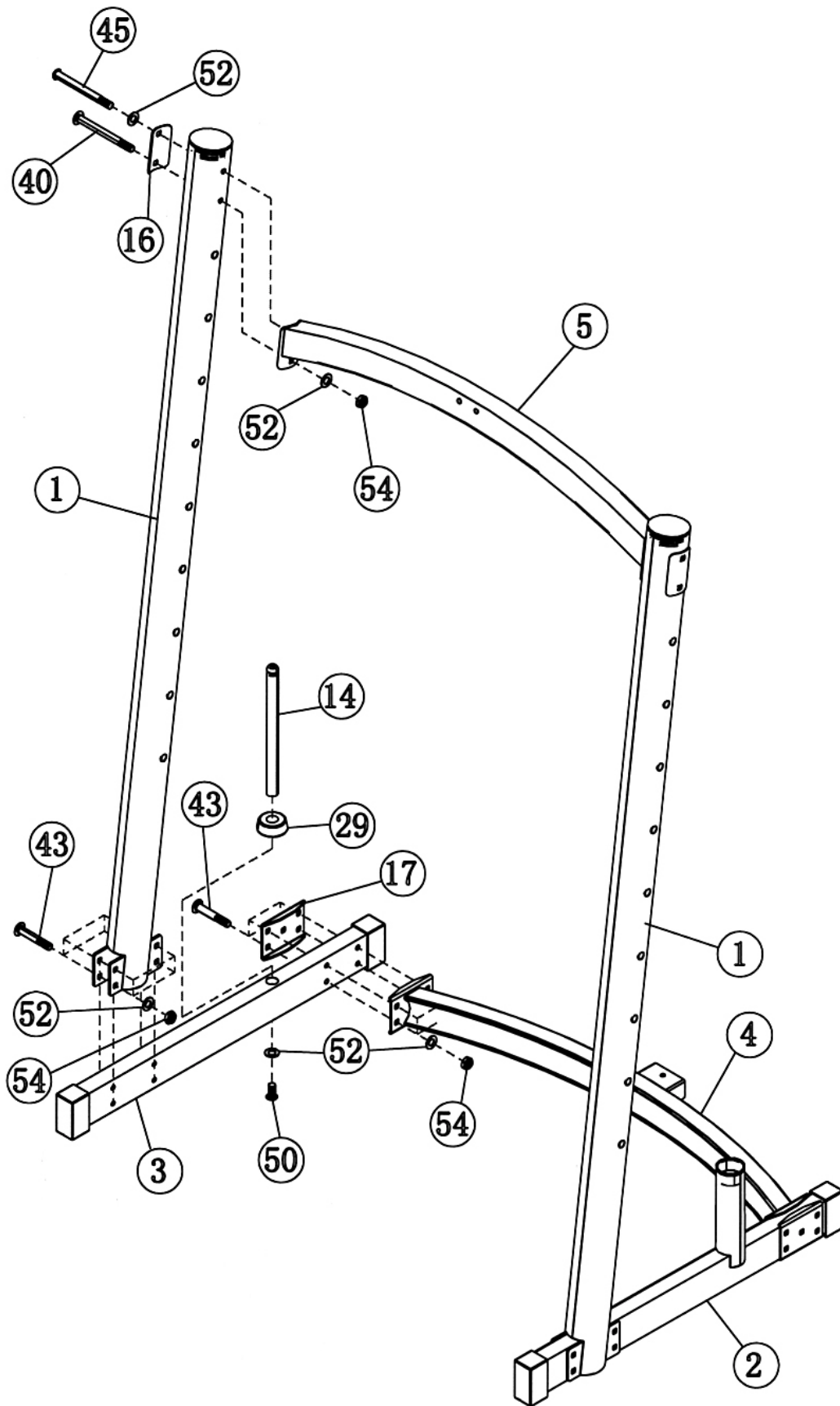

STEP 2 (See Diagram 2)

- A.) Insert two Guide Rods (#13) into the holes on the Weight Gliding Base (#7). Secure each Guide Rod with one M10 x $\frac{3}{4}$ " Allen Bolt (#50) and $\varnothing \frac{3}{4}$ " Washer (#52).
- B.) Slide two $\varnothing 2 \frac{1}{2}$ " Rubber Bumpers (#29) onto the two Guide Rods to the bottom. Slide the Sliding Frame (#8) onto the two Guide Rods.
- C.) Attach the Weight Gliding Base to the Rear Base Frame (#4). Secure the side hole with one M10 x 4" Carriage Bolt (#41), one $\varnothing \frac{3}{4}$ " Washer (#52), and one M10 Aircraft Nut (#54), secure the top hole with one M10 x $\frac{3}{4}$ " Allen Bolt (#50) and one $\varnothing \frac{3}{4}$ " Washer (#52).
- D.) Attach the Upper Frame (#6) to Top Beam (#5) and the two Guide Rods.
- E.) Secure the Upper Frame to the Top Beam with two M10 x 2 $\frac{3}{4}$ " Carriage Bolts (#42), two $\varnothing \frac{3}{4}$ " Washers (#52), and two M10 Aircraft Nuts (#54).
- F.) Secure the Top Beam to the two Guide Rods with two M10 x $\frac{3}{4}$ " Allen Bolts (#50) and two $\varnothing \frac{3}{4}$ " Washes (#52).
- G.) **Securely tighten all Nuts and Bolts installed in Step-1 and Step-2.**

DIAGRAM 2

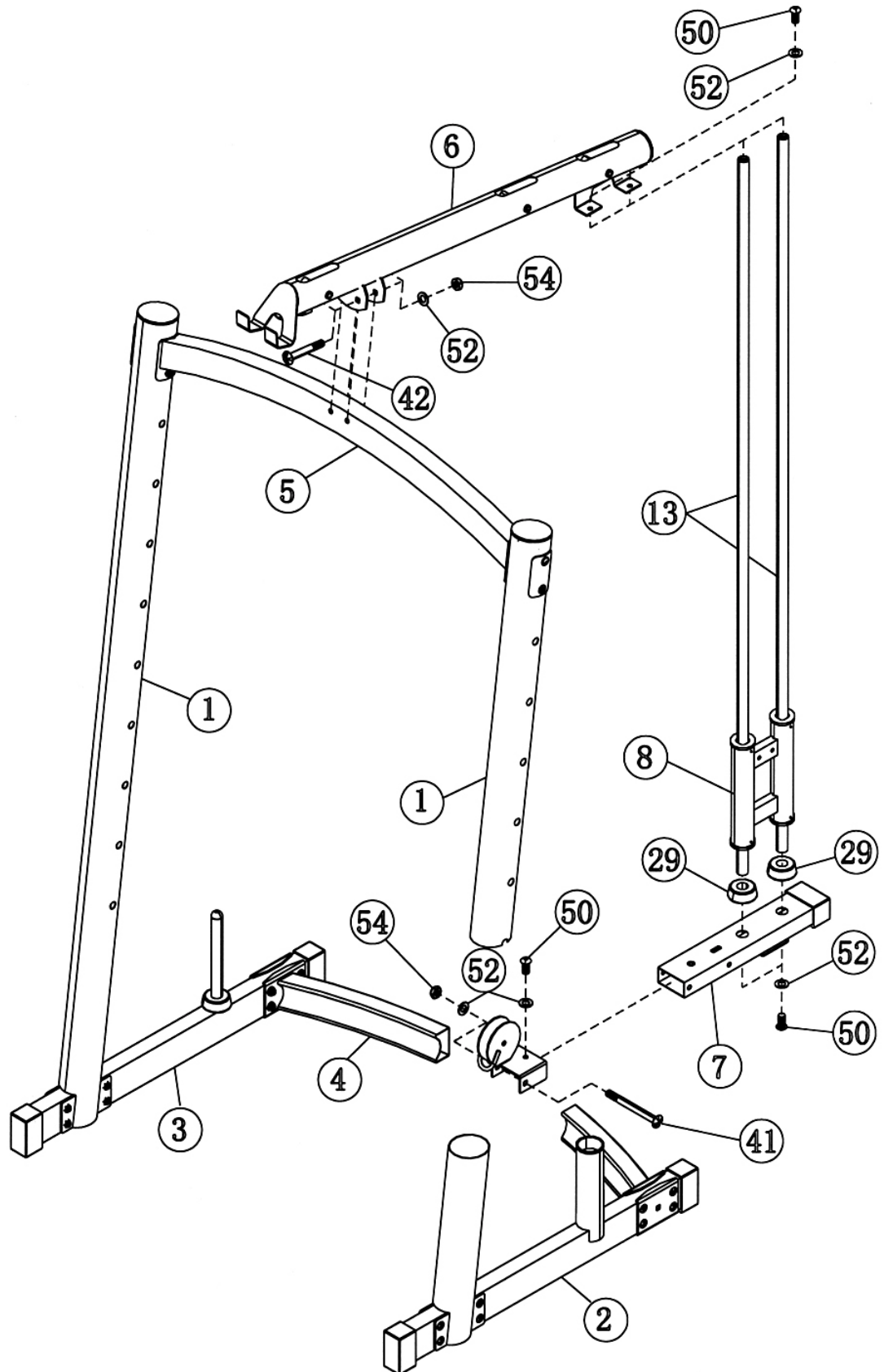

STEP 3 (See Diagram 3)

- A.) Attach the Sliding Weight Post (#15) to the Sliding Frame (#8). Secure it with two M8 x 1 3/8" Carriage Bolts (#44), two Ø 5/8" Washers (#53), and two M8 Aircraft Nut (#55). **Make sure the triangular cable connecting bracket faces up.**
- B.) Attach one 128" Cable (#24) to the front opening on Upper Frame (#6).
- C.) Attach a Pulley (#39) to the opening. Secure it with M10 x 3 3/4" Allen Bolt (#46), two Ø 3/4" Washer (#52), and one M10 Aircraft Nut (#54).
- D.) Draw the Cable over the Pulley toward the back of the machine. **Make Sure the ball stopper on Cable is underneath the Frame.**
- E.) Draw the Cable to the second opening on the Upper Frame. Repeat B to install a Pulley.
- F.) Draw the Cable around the Pulley and then downward. Attach a Pulley to the two Double Floating Pulley Brackets (#25). Secure the Pulley to the top hole on the Brackets with one M10 x 1 3/4" Allen Bolt (#48), two Ø 3/4" Washers (#52), and one M10 Aircraft Nut (#54).
- G.) Draw the Cable around the Pulley then upward to the opening on the rear of Upper Frame. Let the Brackets hanging for now.
- H.) Repeat B to install another Pulley. Draw the Cable around the Pulley then downward through the two Guide Rods (#13) to the triangular bracket on the Sliding Weight Post.
- I.) Secure the end of Cable to the bracket with one M10 X 3/4" Allen Bolt (#50), two Ø 3/4" Washers (#52), and one M10 Aircraft Nut (#54).
- J.) Connect the Lat Bar (#26) to the Cable with two Hooks (#56) and one 10-link Chain (#57).

DIAGRAM 3

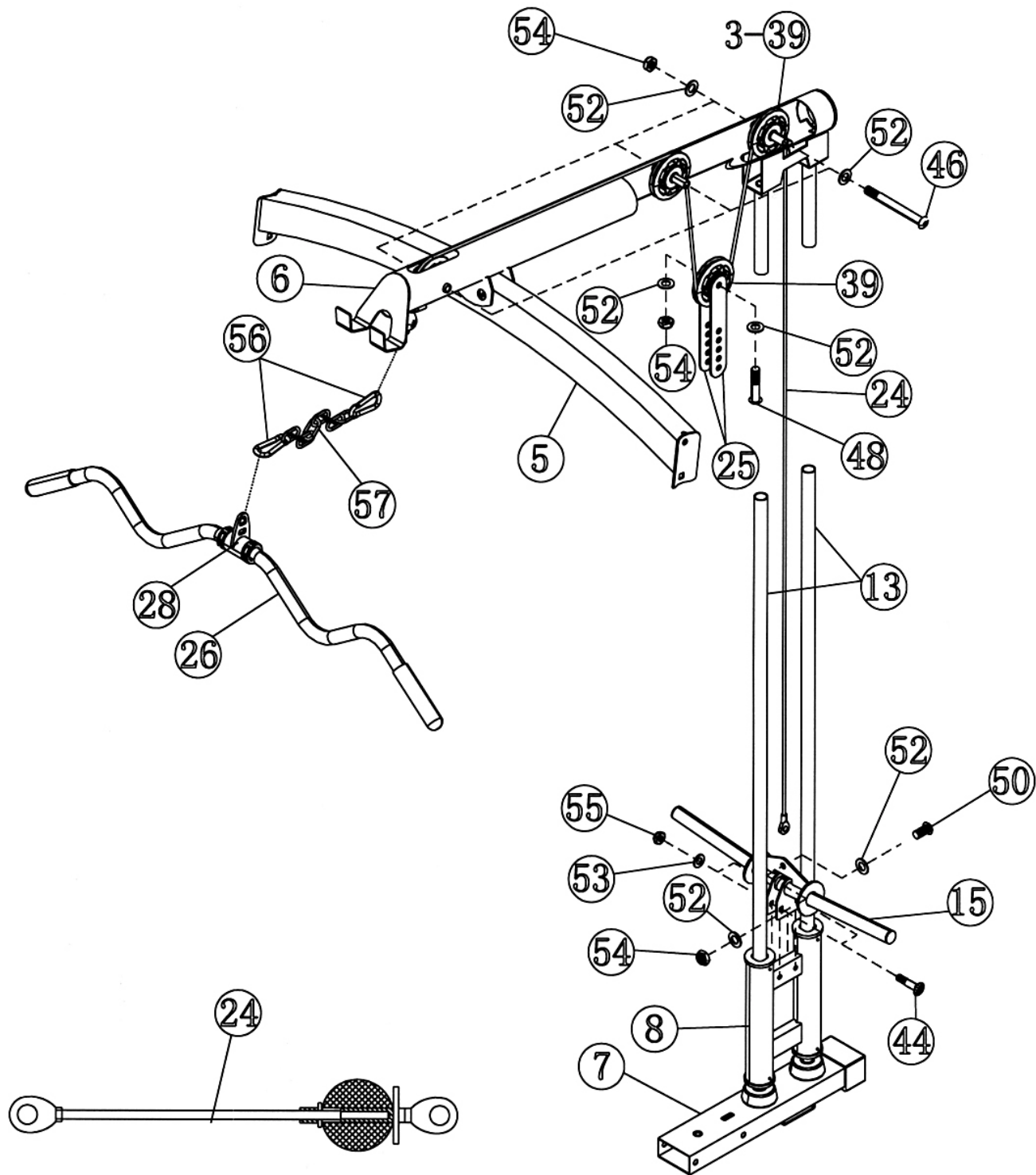

STEP 4 (See Diagram 4)

- A.) Attach the 128" Cable (#24) to the open Pulley bracket on Rear Base Frame (#4).
- B.) Attach a Pulley to the bracket. Secure it with one M10 x 1 3/4" Allen Bolt (#48), two Ø 3/4" Washers (#52), and one M10 Aircraft Nut (#54).
- C.) Draw the Cable around the Pulley then upward to the Double Floating Pulley Brackets (#25) installed in Step-3. Repeat B to install a Pulley.
- D.) Draw the Cable around the Pulley then downward to the open hole on the Weight Glide Base (#7). Secure the end of the Cable to the open hole with M10 x 4" Allen Bolt (#47), two Ø 3/4" Washers (#52), and one M10 Aircraft Nut (#54).
- E.) Adjust the tension of the Cable system by adjusting the Pulley position on the Double Floating Pulley Brackets. If the Cable is too loose, move up the Pulley one hole. If the cable is too tight, move down the Pulley one hole.
- F.) Connect the Shiver Bar (#27) to the Cable with two Hooks (#56) and one 15-link Chain (#58).

DIAGRAM 4

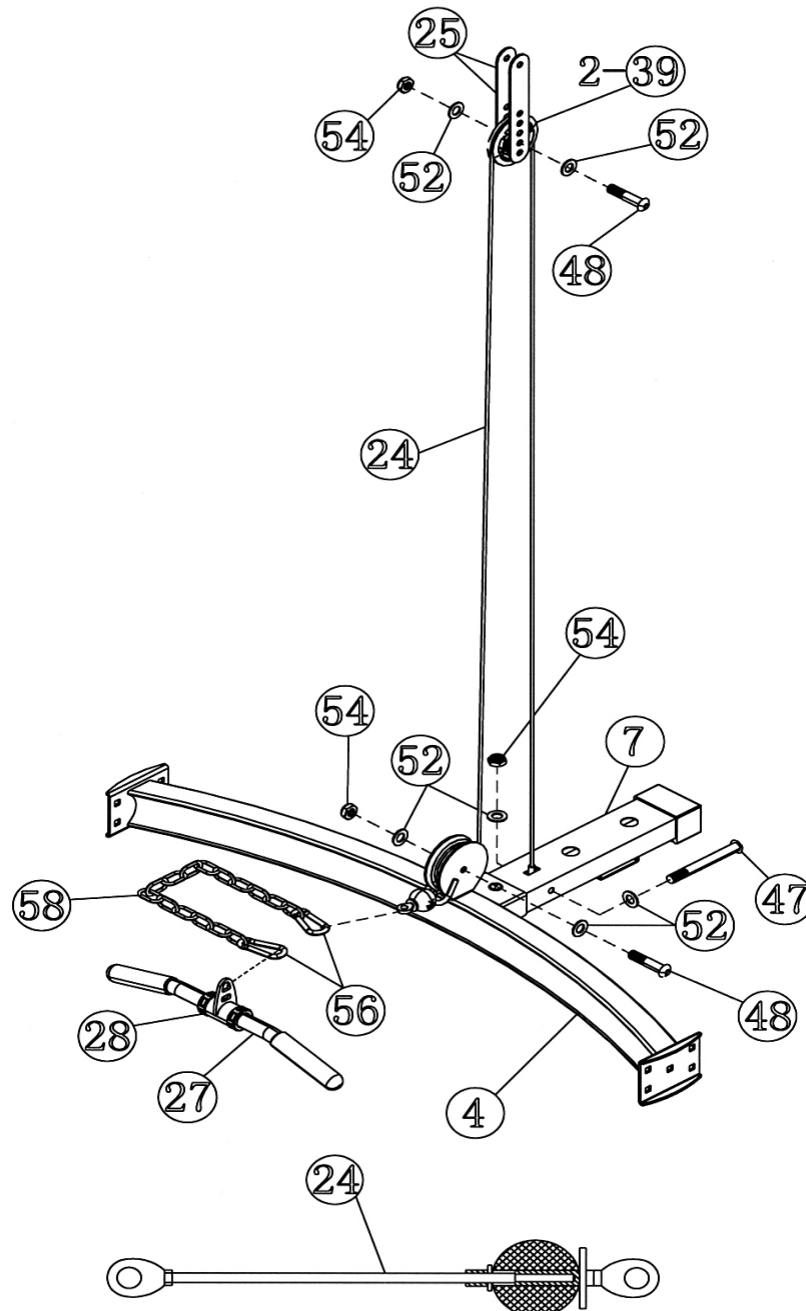

STEP 5 (See Diagram 5)

- A.) Slide two Olympic Sleeves (#35) to the Weight Sliding Post (#8). Attach two Spring Clips (#59) to the Sleeves.
- B.) Attach the Left and Right Bar Catches (#11 & #12), Left and Right Safety Catches (#9 & #10) to selected slot on the two Upright Beams (#1).

DIAGRAM 5

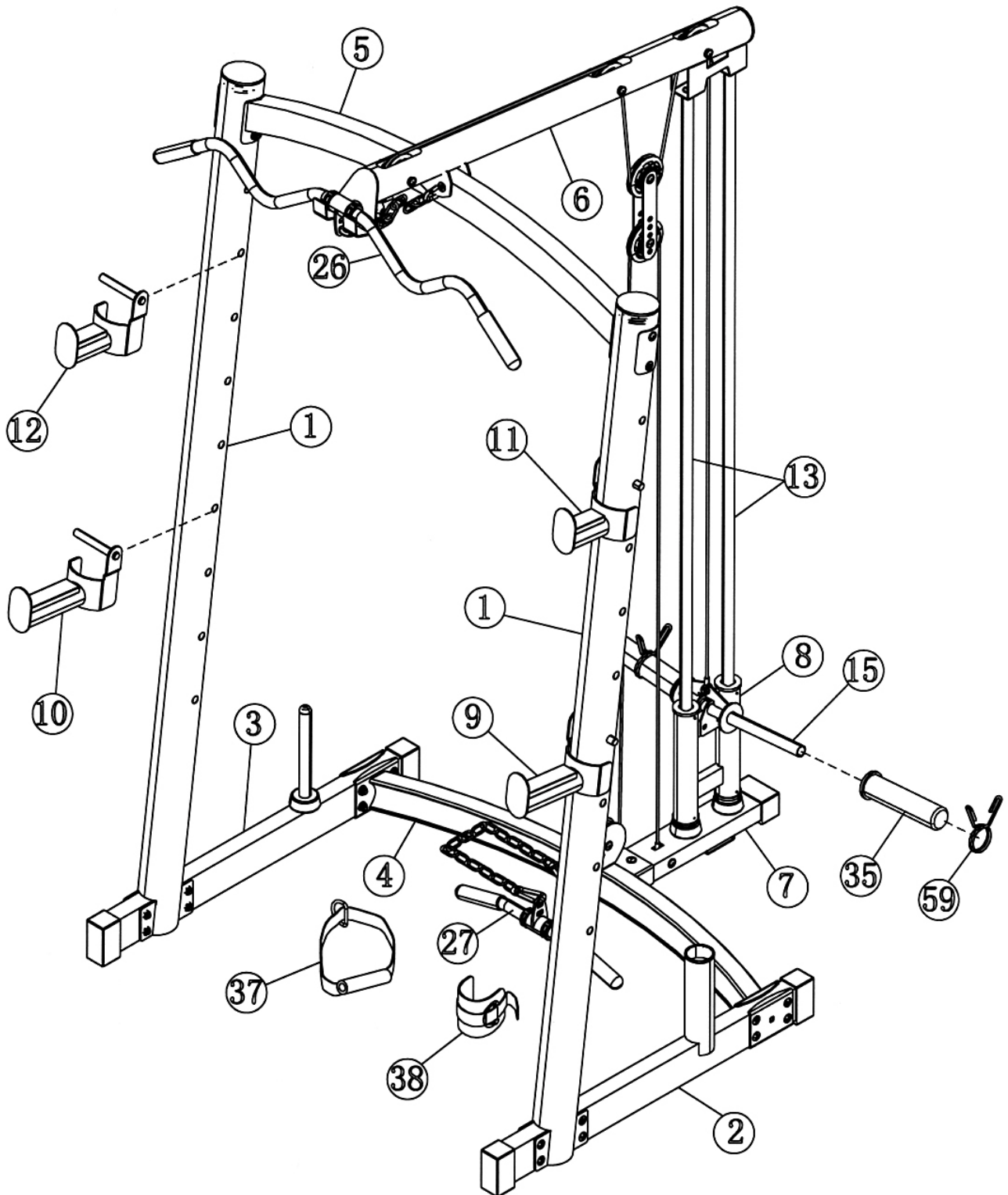

CAGE EXPLODED DIAGRAM

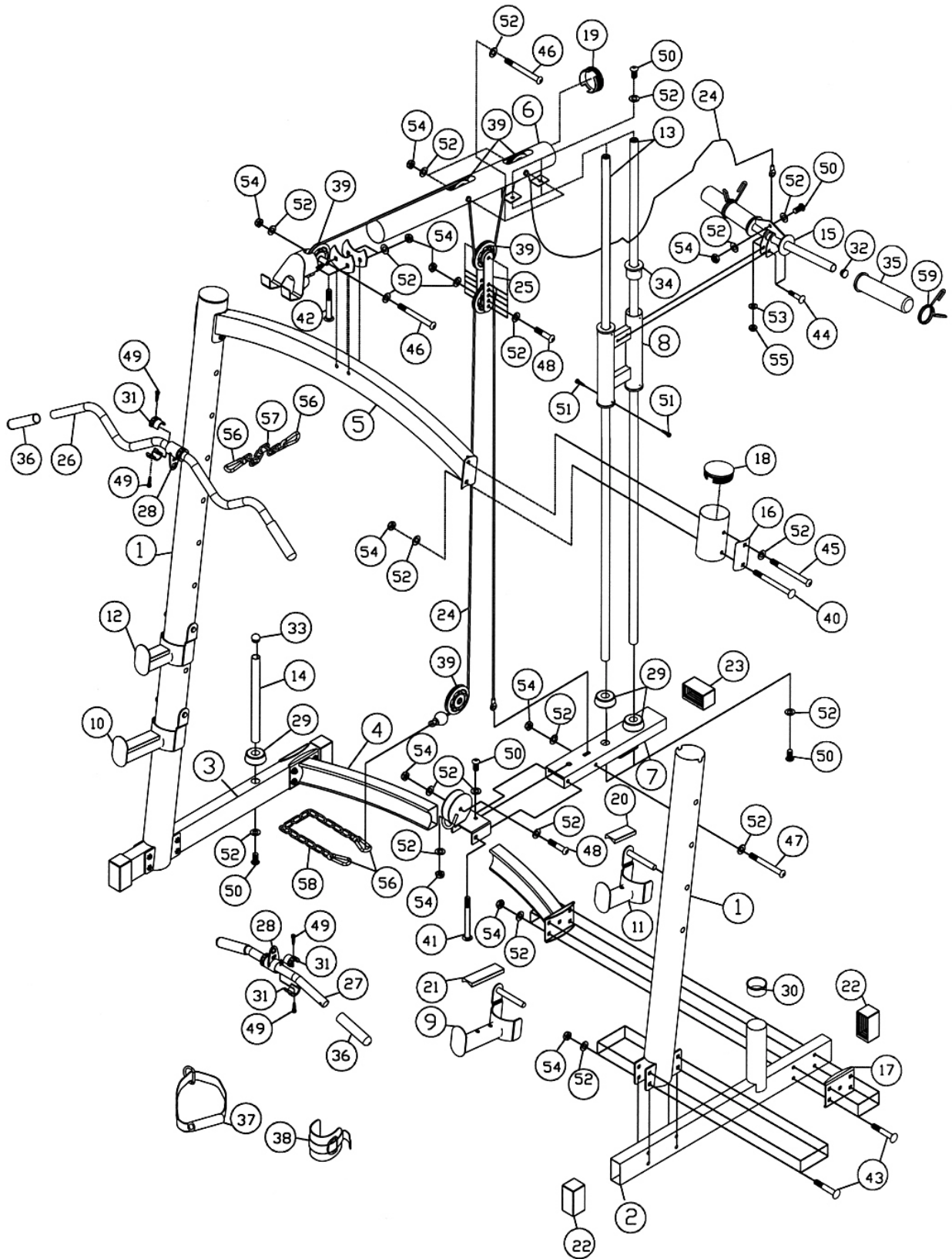

CAGE PART LIST

KEY NO.	DESCRIPTION	Q'ty			
1	Upright Beam	2	51	ST3.8 Philips Screw	8
2	Left Stabilizer	1	52	Ø 3/4" Washer	45
3	Right Stabilizer	1	53	Ø 5/8" Washer	2
4	Rear Base Frame	1	54	M10 Aircraft Nut	29
5	Top Beam	1	55	M8 Aircraft Nut	2
6	Upper Frame	1	56	Hook	4
7	Weight Glide Base	1	57	10-link Chain	1
8	Sliding Frame	1	58	15-link Chain	1
9	Left Safety Catch	1	59	Spring Clip	2
10	Right Safety Catch	1		#4 Allen Wrench (Tool)	1
11	Left Bar Catch	1		#6 Allen Wrench (Tool)	1
12	Right Bar Catch	1			
13	Guide Rod	2			
14	Weight Storage Post	1			
15	Sliding Weight Post	1			
16	4" x 2 3/8" Curved Bracket	2			
17	4 3/4" x 3 1/4" Bracket	2			
18	Ø 3 1/2" End Cap	2			
19	Ø 3" End Cap	1			
20	3 1/2" x 1 5/8" Rubber Bumper	2			
21	5 1/2" x 1 5/8" Rubber Bumper	2			
22	Stabilizer End Cap	4			
23	Weight Glide Base End Cap	1			
24	128" Cable	2			
25	Double Floating Pulley Bracket	2			
26	Lat Bar	1			
27	Shiver Bar	1			
28	Rotate Ring	2			
29	Ø 2 1/2" Rubber Bumper	3			
30	Sleeve	1			
31	Plastic Ring	8			
32	Ø 1" End Cap	2			
33	Ø 1" Cone-shaped End Cap	1			
34	Sliding Sleeve	4			
35	Olympic Sleeve	2			
36	6" Handle Grip	4			
37	Single Handle	1			
38	Ankle Strap	1			
39	Pulley	6			
40	M10 x 4 1/8" Carriage Bolt	2			
41	M10 x 4" Carriage Bolt	1			
42	M10 x 2 3/4" Carriage Bolt	2			
43	M10 x 2 3/8" Carriage Bolt	16			
44	M8 x 1 3/8" Carriage Bolt	2			
45	M10 x 4 1/8" Allen Bolt	2			
46	M10 x 3 3/4" Allen Bolt	3			
47	M10 x 4" Allen Bolt	1			
48	M10 x 1 3/4" Allen Bolt	3			
49	Rivet	8			
50	M10 x 3/4" Allen Bolt	7			

BENCH HARDWARE PACK

NOTE: The following parts are not drawn to scale. Please use your own ruler to measure the size.



#34 M8 x 1 $\frac{5}{8}$ " Allen Bolt (Qty 12)

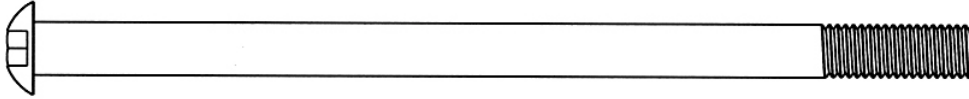

#35 M8 x 5 $\frac{1}{8}$ " Allen Bolt (Qty 1)

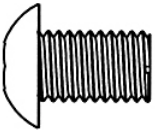

#36 M10 x $\frac{5}{8}$ " Allen Bolt (Qty 1)

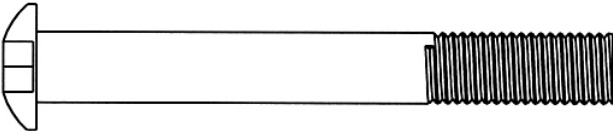

#38 M10 x 3 $\frac{1}{8}$ " Allen Bolt (Qty 1)

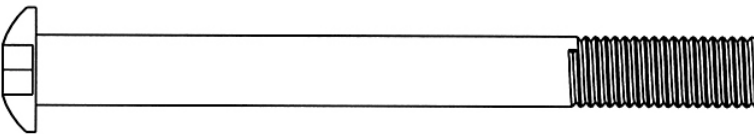

#40 M10 x 4" Allen Bolt (Qty 2)

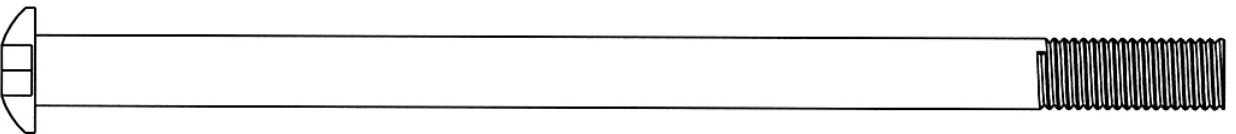

#39 M10 x 6 $\frac{1}{2}$ " Allen Bolt (Qty 1)

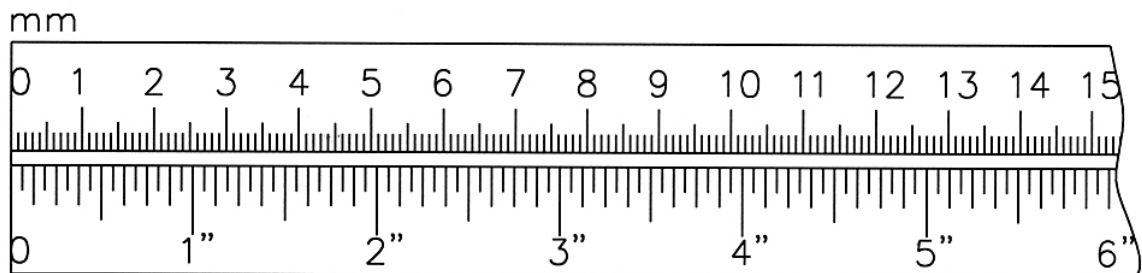

BENCH HARDWARE PACK

NOTE: The following parts are not drawn to scale. Please use your own ruler to measure the size.

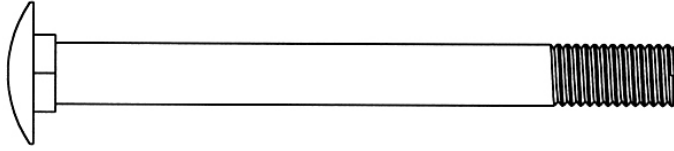

#41 M10 x 4" Carriage Bolt (Qty 5)

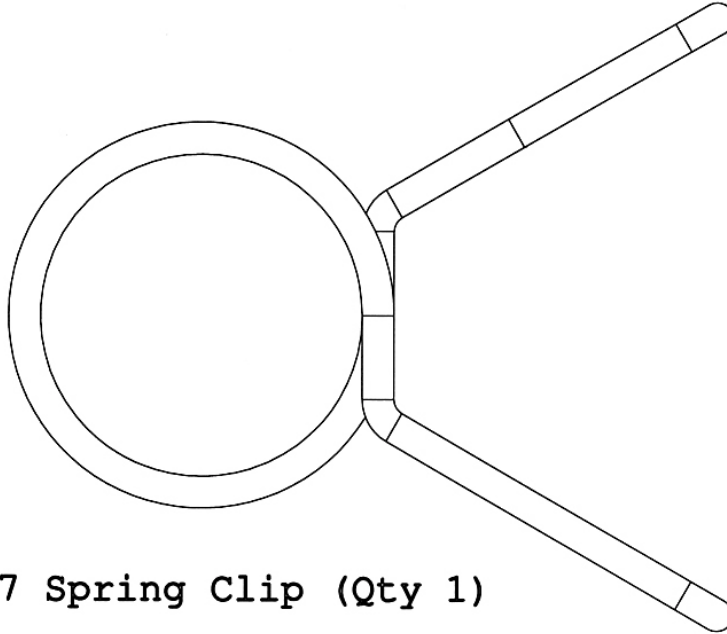

#27 Spring Clip (Qty 1)

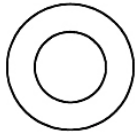

#31 $\text{Ø } \frac{3}{4}$ " Washer
(Qty 14)

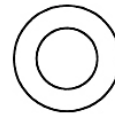

#30 $\text{Ø } \frac{5}{8}$ " Washer
(Qty 18)

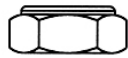

#33 M10 Aircraft Nut
(Qty 9)



#32 M8 Aircraft Nut
(Qty 5)

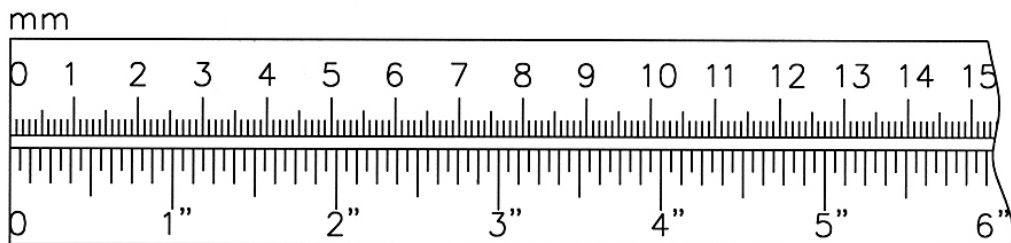

BENCH ASSEMBLY INSTRUCTION

STEP 1 (See Diagram 1)

- A.) Attach the Bench Base Frame (#6) to the Rear Stabilizer (#7). Secure the side-holes with two M10 x 4" Carriage Bolts (#41), two $\text{\O} \frac{3}{4}$ " Washers (#31), and two M10 Aircraft Nuts (#33). Secure the top hole with one M10 x $\frac{5}{8}$ " Allen Bolt (#36) and one $\text{\O} \frac{3}{4}$ " Washer (#31).
- B.) Attach the Wheel Set (#25) to the bracket on Rear Stabilizer. Secure it with one M8 x $5 \frac{1}{8}$ " Allen Bolt (#35), two $\text{\O} \frac{5}{8}$ " Washers (#30), and one M8 Aircraft Nut (#32).

DIAGRAM 1

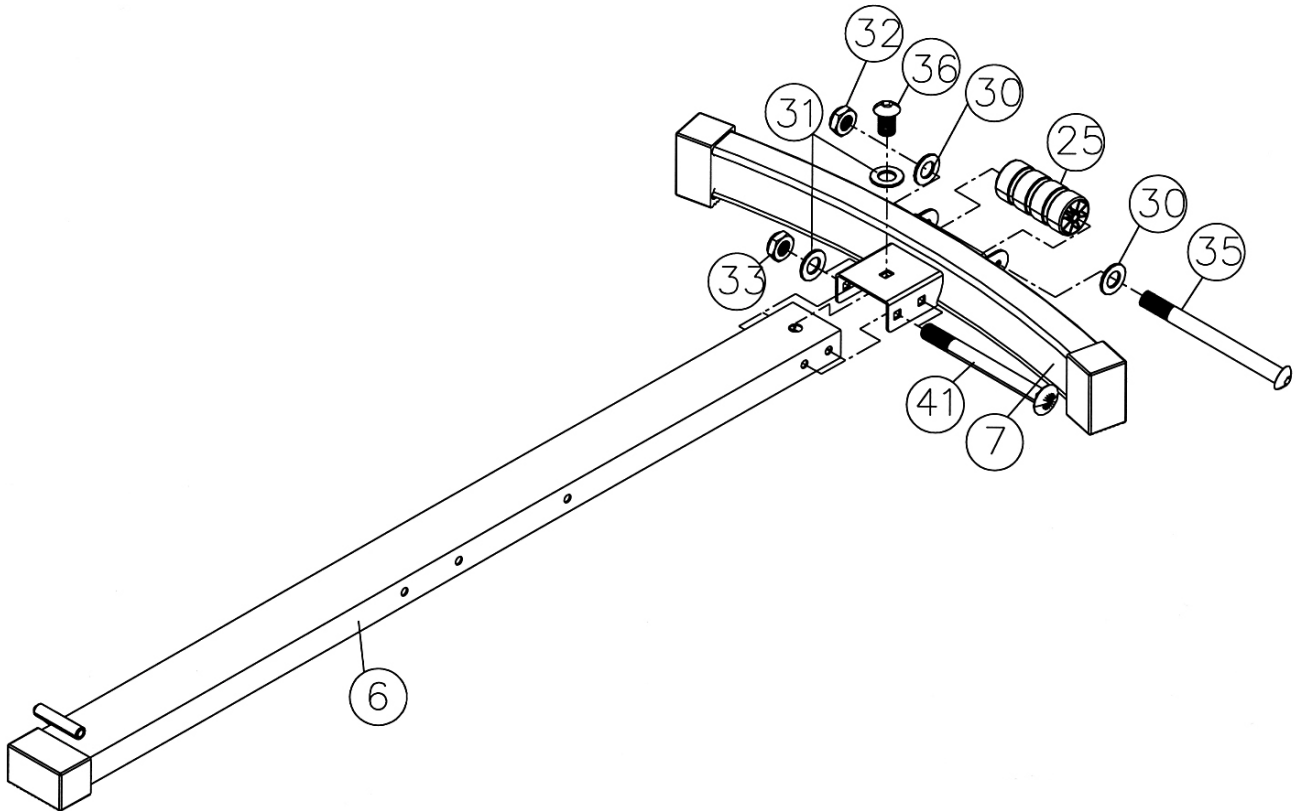

STEP 2 (See Diagram 2)

- A.) Attach the Main Seat Support (#1) to the Bench Base Frame (#6). Secure it with three M10 x 4" Carriage Bolts (#41), three $\text{\O} \frac{3}{4}$ " Washers (#31), and three M10 Aircraft Nuts (#33).
- B.) Attach the Front & Rear Seat Bracket (#4 & #5) to Main Seat Support. Secure each Bracket with one M10 x 4" Allen Bolt (#40), two $\text{\O} \frac{3}{4}$ " Washers (#31), and one M10 Aircraft Nut (#33).

DIAGRAM 2

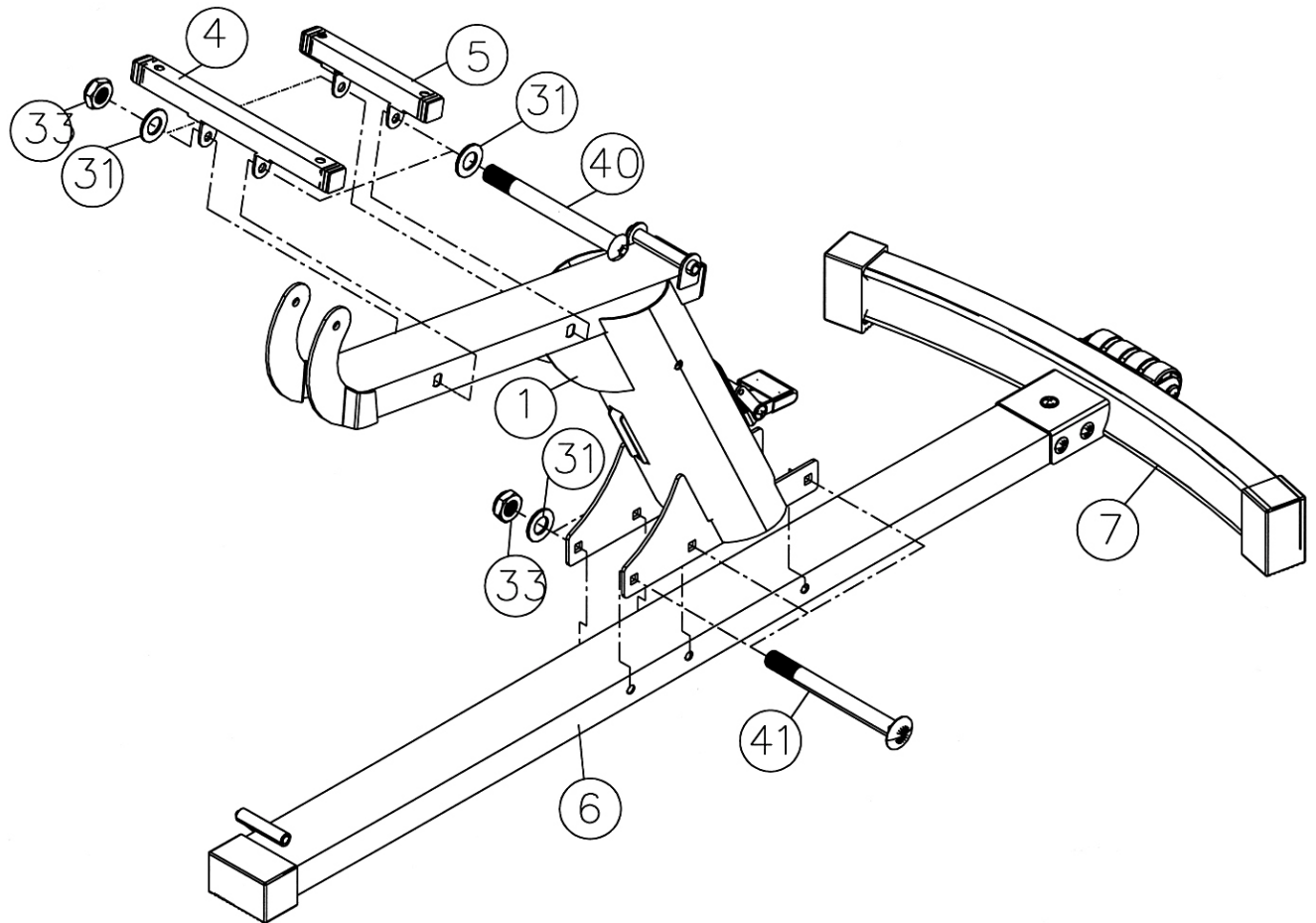

STEP 3 (See Diagram 3)

- A.) Align the bracket on the Backrest Adjustment Support (#8) in between the two Backrest Supports (#3). Secure it with four M8 x 1 5/8" Allen Bolts (#34), eight Ø 5/8" Washers (#30), and four M8 Aircraft Nuts (#32). **Do not tighten the Nuts and Bolts yet.**
- B.) Insert the Backrest Adjustment Support into the opening on the Main Seat Support (#1). Press or step down on the Backrest Adjustment Lever (#9) to allow the Support to go through.
- C.) Attach the bottom side-holes on the two Backrest Supports to the pivot on the Main Seat Support. Secure it with one M10 x 6 1/2" Allen Bolt (#39), two Ø 3/4" Washers (#31), and one M10 Aircraft Nut (#33).
- D.) **Securely tighten all Nuts and Bolts in B & C.**
- E.) **Do not over tighten the Nut and Bolt in C.**
- F.) **Make sure the Backrest Supports are able to swivel.**

DIAGRAM 3

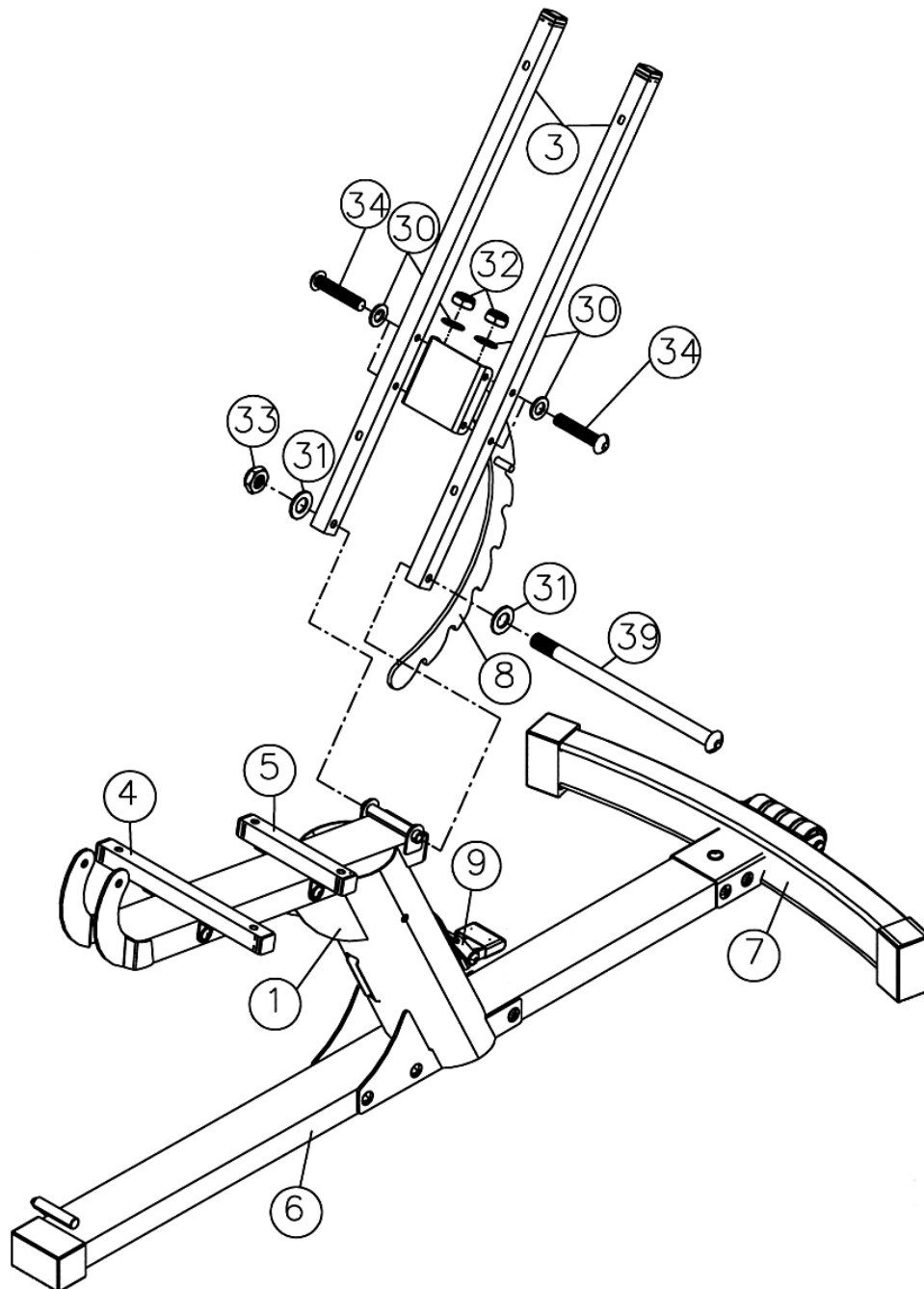

STEP 4 (See Diagram 4)

- A.) Attach the Backrest Board (#13) to the Backrest Supports (#3). Secure it with four M8 x 1 5/8" Allen Bolts (#34) and four Ø 5/8" Washers (#30).
- B.) Attach the Seat Pad (#12) to Front & Rear Seat Bracket (#4 & #5). Secure them with four M8 x 1 5/8" Allen Bolts (#34) and four Ø 5/8" Washers (#30).
- C.) Pull up the Backrest Adjustment Support (#8) or press down the Backrest Adjustment Lever (#9) to adjust the Backrest incline position.

DIAGRAM 4

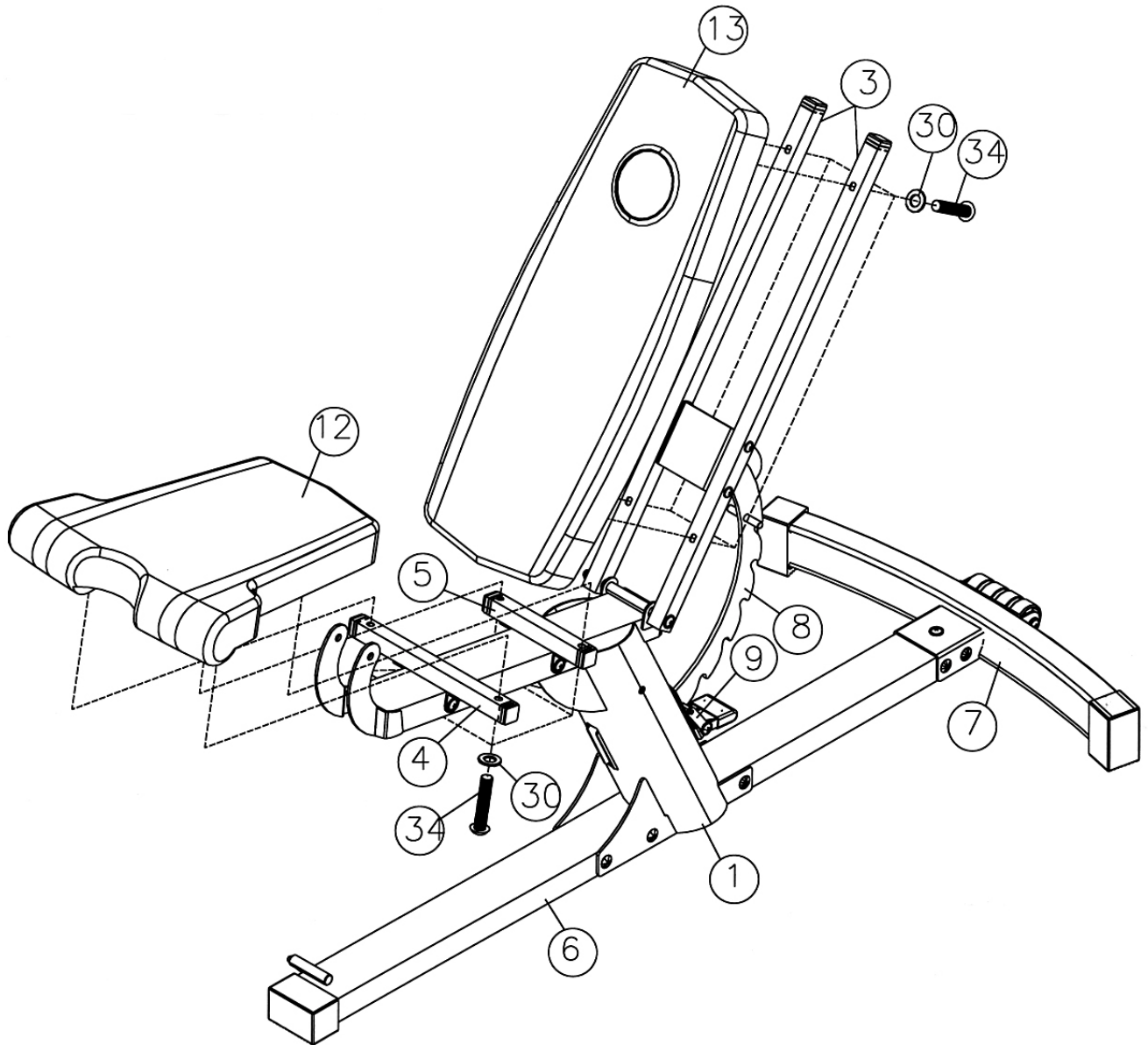

STEP 5 (See Diagram 5)

- A.) Attach the Leg Developer (#2) to Main Seat Support (#1). Secure it with one M10 x 3 1/8" Allen Bolt (#38), two Ø 3/4" Washers (#31), and one M10 Aircraft Nut (#33).
- B.) Insert two Foam Tubes (#10) halfway through the holes on Leg Developer. Push four Foam Roll Rolls (#16) onto the Tubes from both ends. Plug four Foam Roll End Caps (#17) into the ends.
- C.) Slide an Olympic Sleeve (#28) on the weight post on Leg Developer. Attach a Spring Clip (#27) to the Sleeve.

DIAGRAM 5

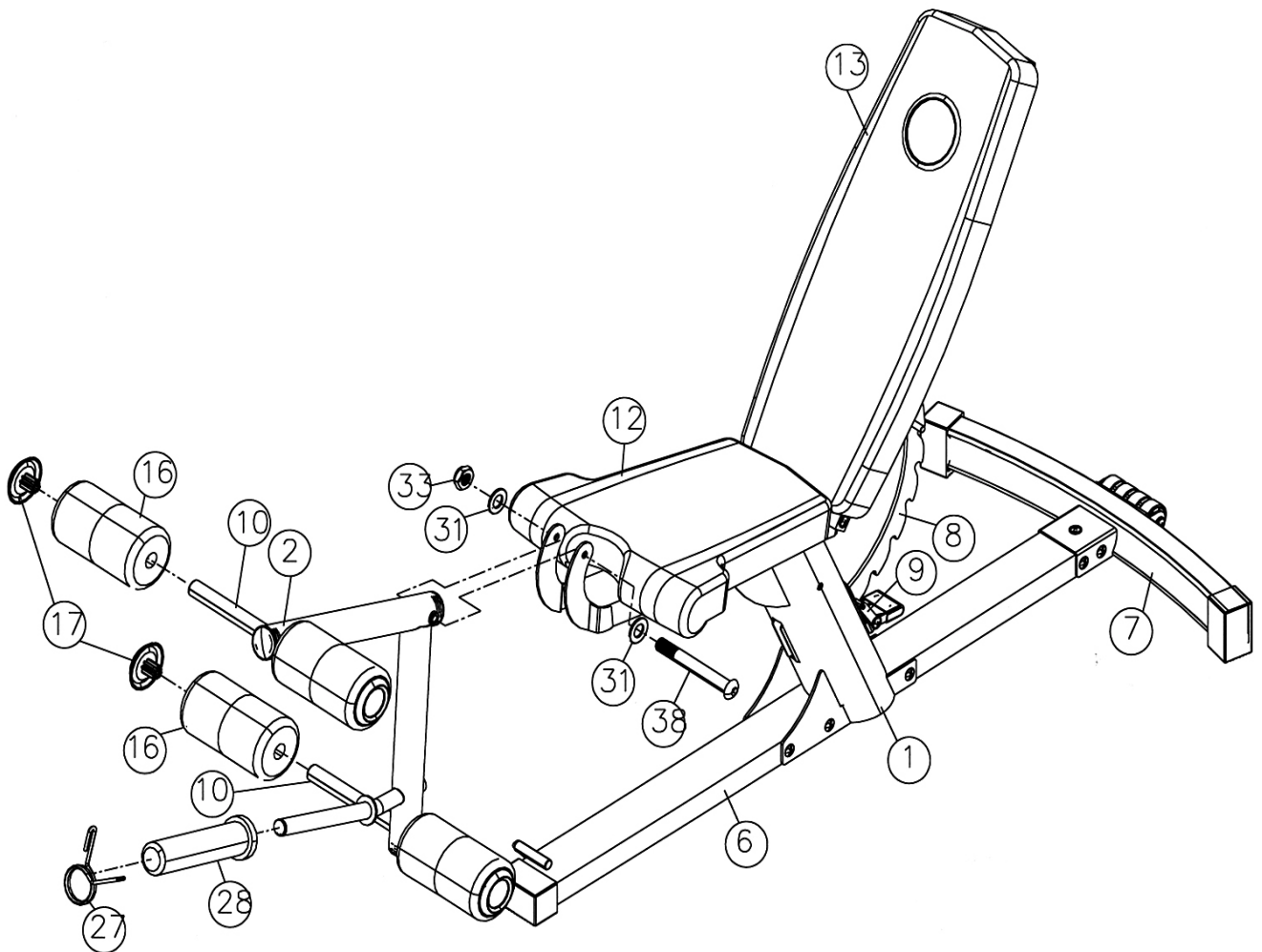

BENCH EXPLODED DIAGRAM

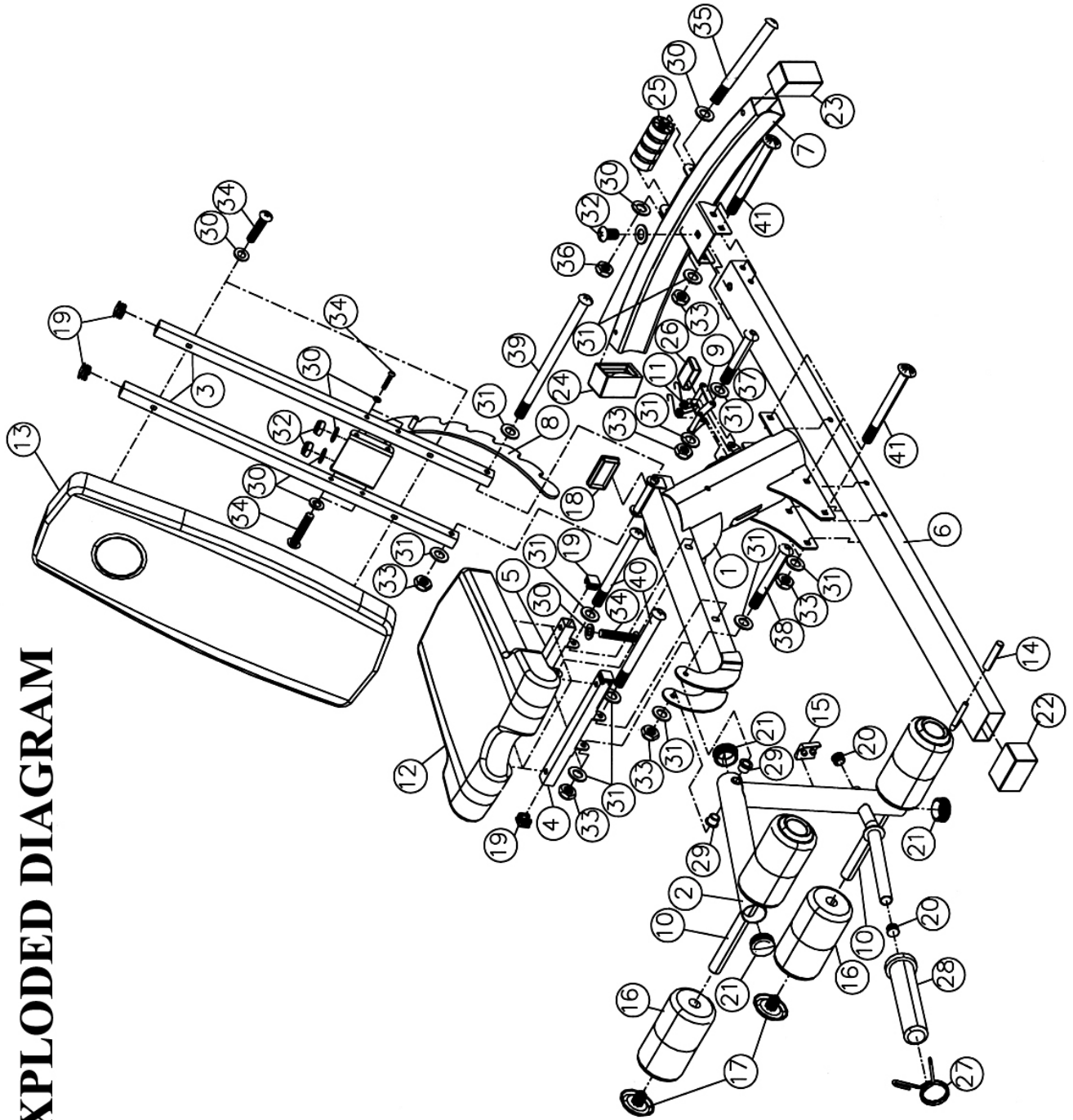

BENCH PARTS LIST

KEY NO.	DESCRIPTION	Q'ty
1	Main Seat Support	1
2	Leg Developer	1
3	Backrest Support	2
4	Front Seat Bracket	1
5	Rear Seat Bracket	1
6	Bench Base Frame	1
7	Rear Stabilizer	1
8	Backrest Adjustment Support	1
9	Backrest Adjustment Lever	1
10	Foam Tube	2
11	Spring	1
12	Seat Pad	1
13	Backrest Board	1
14	2 ¾" Grip	1
15	2" x 1 5/8" Rubber Bumper	1
16	Foam Roll	4
17	Foam Roll End Cap	4
18	1 5/8" x 3 1/8" End Cap	1
19	1" Square End Cap	6
20	Ø 1" End Cap	2
21	Ø 2" End Cap	3
22	Base Frame End Cap	1
23	Rear Stabilizer Left End Cap	1
24	Rear Stabilizer Right End Cap	1
25	Wheel Set	1
26	Lever Cover	1
27	Spring Clip	1
28	Olympic Sleeve	1
29	Ø ¾" Leg Developer Bushing	2
30	Ø 5/8" Washer	18
31	Ø ¾" Washer	16
32	M8 Aircraft Nut	5
33	M10 Aircraft Nut	10
34	M8 x 1 5/8" Allen Bolt	12
35	M8 x 5 1/8" Allen Bolt	1
36	M10 x 5/8" Allen Bolt	1
37	M10 x 2 ½" Allen Bolt	1
38	M10 x 3 1/8" Allen Bolt	1
39	M10 x 6 ½" Allen Bolt	1
40	M10 x 4" Allen Bolt	2
41	M10 x 4" Carriage Bolt	5

IMPEX[®] INC.

LIMITED WARRANTY

IMPEX Inc. ("IMPEX[®]") warrants this product to be free from defects in workmanship and material, under normal use and service conditions, for a period of two years on the Frame from the date of purchase. This warranty extends only to the original purchaser. IMPEX's obligation under this Warranty is limited to replacing or repairing, at IMPEX's option.

All returns must be pre-authorized by IMPEX. Pre-authorization may be obtained by calling IMPEX Customer Service Department at 1-800-999-8899. All freights on products returned to IMPEX must be prepaid by the customer. This warranty does not extend to any product or damage to a product caused by or attributable to freight damage, abuse, misuse, improper or abnormal usage or repairs not provided by an IMPEX authorized service center or for products used for commercial or rental purposes. No other warranty beyond that specifically set forth above is authorized by IMPEX.

IMPEX is not responsible or liable for indirect, special or consequential damages arising out of or in connection with the use or performance of the product or other damages with respect to any economic loss, loss of property, loss of revenues or profits, loss of enjoyments or use, costs of removal, installation or other consequential damages or whatsoever natures. Some states do not allow the exclusion or limitation of incidental or consequential damages. Accordingly, the above limitation may not apply to you.

The warranty extended hereunder is in lieu of any and all other warranties and any implied warranties of merchantability or fitness for a particular purpose is limited in its scope and duration to the terms set forth herein. Some states do not allow limitations on how long an implied warranty lasts. Accordingly, the above limitation may not apply to you.

This warranty gives you specific legal right. You may also have other rights which vary from state to state. Register on-line at www.impex-fitness.com

IMPEX[®] INC.
14777 Don Julian
City of Industry, CA 91746

ORDERING REPLACEMENT PARTS

Replacement parts can be ordered by calling our Customer Service Department toll-free at **1-800-999-8899** during our regular business hours: Monday through Friday, 9 am until 5 pm Pacific standard time.

info@impex-fitness.com

When ordering replacement parts, always give the following information.

1. Model
2. Description of Parts
3. Part Number
4. Date of Purchase