

NOTE:  
Please read all instructions  
carefully before using this  
product

Table of Contents

Safety Notice

Hardware Pack

Assembly Instruction

Parts List

Warranty

Ordering Parts

Model  
BF-1200

Retain This  
Manual for  
Reference

07-20-09

OWNER'S  
MANUAL



## Deluxe Elliptical Machine BF-1200

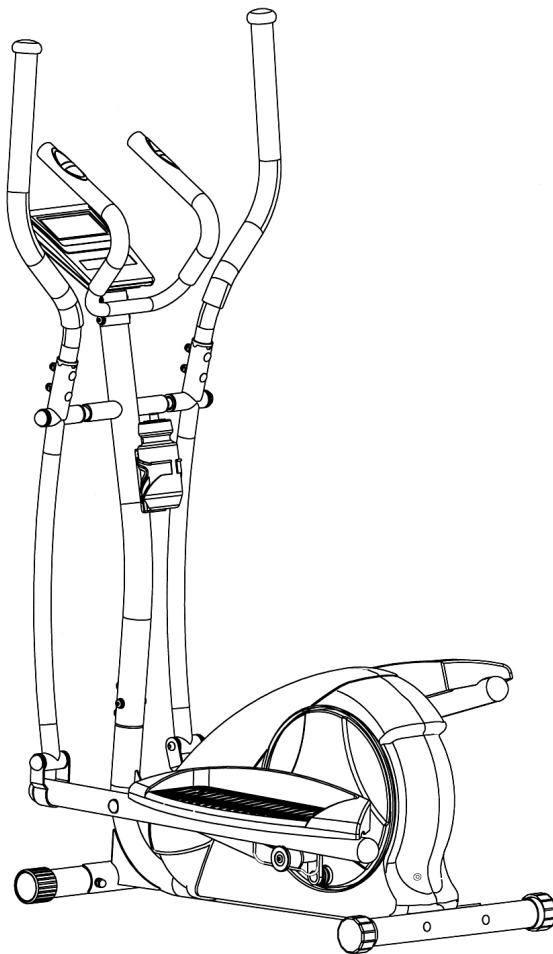

**IMPEX<sup>®</sup> INC.**

14777 DON JULIAN RD., CITY OF INDUSTRY, CA 91746

Tel: (800) 999-8899 Fax: (626) 961-9966

[www.impex-fitness.com](http://www.impex-fitness.com)

[info@impex-fitness.com](mailto:info@impex-fitness.com)

# TABLE OF CONTENTS

BEFORE YOU BEGIN.....	1
IMPORTANT SAFETY NOTICES.....	2
HARDWARE PACK.....	4
ASSEMBLY INSTRUCTIONS.....	5
EXPLODED DIAGRAM.....	15
PARTS LIST.....	17
WARRANTY.....	18
ORDERING PARTS.....	18

---

## BEFORE YOU BEGIN

Thank you for selecting the BODY FIT Deluxe Elliptical Machine BF-1200 by IMPEX® INC. For your safety and benefit, read this manual carefully before using the machine. As a manufacturer, we are committed to provide you complete customer satisfaction. If you have any questions, or find there are missing or damaged parts, we guarantee you complete satisfaction through direct assistance from our factory. To avoid unnecessary delays, *please call our TOLL-FREE customer service number.* Our Customer Service Agents will provide immediate assistance to you.

**Toll-Free Customer Service Number**  
**1-800-999-8899**  
**Mon. - Fri. 9 a.m. - 5 p.m. PST**  
**[www.impex-fitness.com](http://www.impex-fitness.com)**  
**[info@impex-fitness.com](mailto:info@impex-fitness.com)**

# **IMPORTANT SAFETY NOTICE**

## **PRECAUTIONS**

This exercise machine is built for optimum safety. However, certain precautions apply whenever you operate a piece of exercise equipment. Be sure to read the entire manual before you assemble or operate your machine. In particular, note the following safety precautions:

1. **Keep children and pets away from the machine at all times. DO NOT leave children unattended in the same room with the machine.**
2. Only one person at a time should use the machine.
3. If the user experiences dizziness, nausea, chest pain, or any other abnormal symptoms, STOP the workout at once. CONSULT A PHYSICIAN IMMEDIATELY.
4. Position the machine on a clear, leveled surface. DO NOT use the machine near water or outdoors.
5. Keep hands away from all moving parts.
6. Always wear appropriate workout clothing when exercising. DO NOT wear robes or other clothing that could become caught in the machine. Running or aerobic shoes are also required when using the machine.
7. Use the machine only for its intended use as described in this manual. DO NOT use attachments not recommended by the manufacturer.
8. Do not place any sharp object around the machine.
9. Disabled person should not use the machine without a qualified person or physician in attendance.
10. Before using the machine to exercise, always do stretching exercises to properly warm up.
11. Never operate the machine if the machine is not functioning properly.
12. The Maximum Weight Capacity is 300 lbs.
13. Read all warnings posted on the exercise bike.
14. Inspect the exercise bike for worn or loose component prior to use. Tighten/replace any loose or wore components prior to use.
15. Care should be taken in mounting or dismounting the machine.
16. This exercise bike is for consumer and home use only.

## **Maintenance and Storage**

1. Inspect and tighten all parts each time you use the machine. Replace any worn parts immediately.
2. The bike can be cleaned using a damp cloth and mild non-abrasive detergent. Do not use solvents.
3. Store the machine IN-DOOR. Excess moisture and water would cause rust on the frame.
4. The machine shall be placed at least 24 inches away from the wall or/and any other object such as furniture to provide safe access to and passage around the machine.
5. To avoid possible injury, the help of two or more people are needed when moving the machine around.
6. Periodically lubricate all moving parts with the Grease supplied by manufacturer, WD-40, or light oil.

**WARNING: BEFORE BEGINNING ANY EXERCISE PROGRAM, CONSULT YOUR PHYSICIAN. THIS IS ESPECIALLY IMPORTANT FOR INDIVIDUALS OVER THE AGE OF 35 OR PERSONS WITH PRE-EXISTING HEALTH PROBLEMS. READ ALL INSTRUCTIONS BEFORE USING ANY FITNESS EQUIPMENT. IMPEX INC. ASSUMES NO RESPONSIBILITY FOR PERSONAL INJURY OR PROPERTY DAMAGE SUSTAINED BY OR THROUGH THE USE OF THIS PRODUCT. SAVE THESE INSTRUCTIONS.**

# WARNING LABEL PLACEMENT

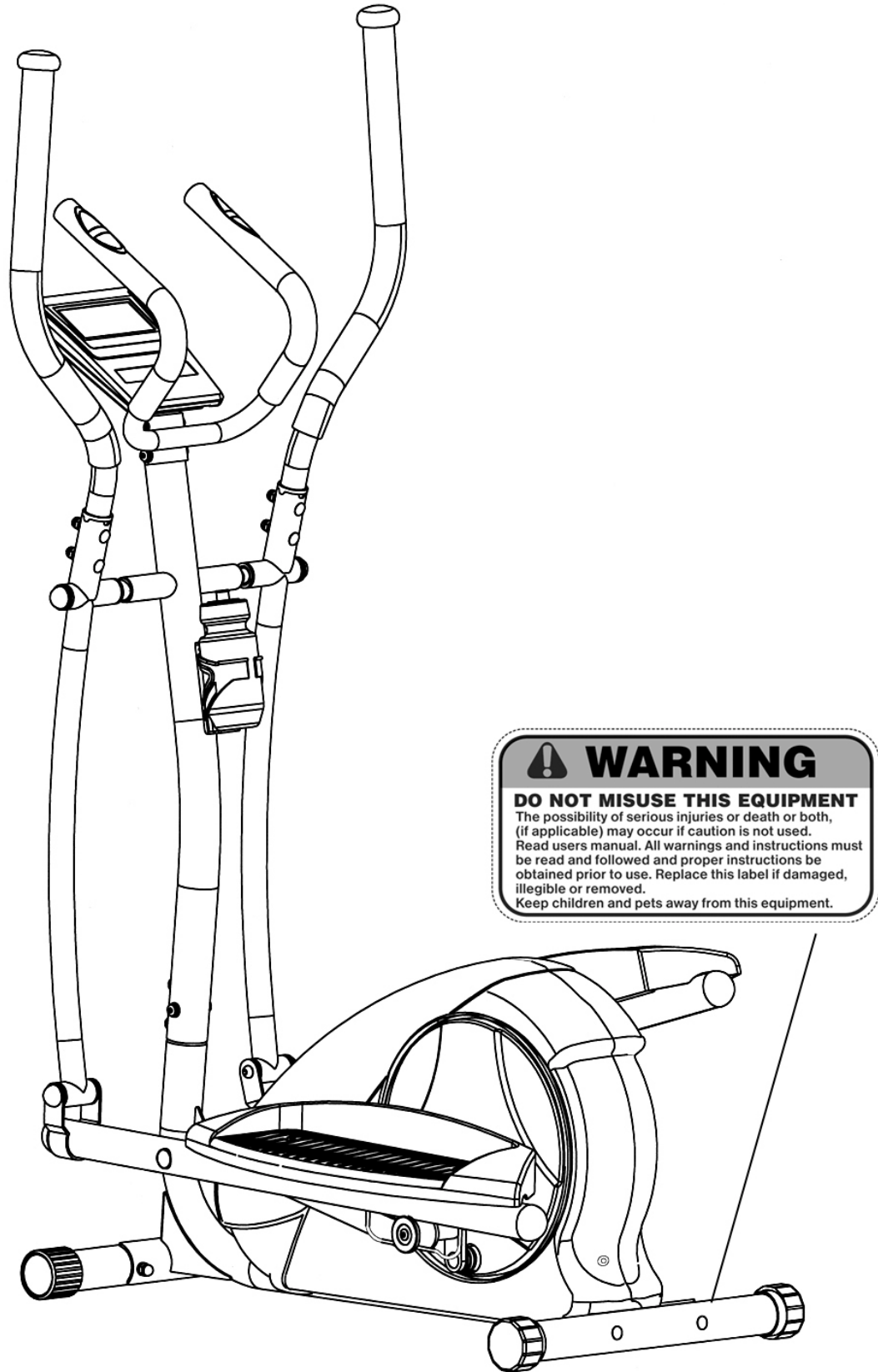

The Warning Label shown here has been placed on the Rear Stabilizer. If the label is missing or illegible, please call customer service at 1-800-999-8899 for replacement. Apply the label in location shown.

# HARDWARE PACK

NOTE: The following parts are not drawn to scale. Please use your own ruler to measure the size.



#5 M8 Nut Cap (Qty 4)

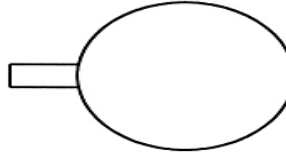

Grease (Qty 1)



#19 3  $\frac{1}{4}$ " Axle (Qty 2)



#35 M8 x 2  $\frac{1}{2}$ " Carriage Bolt (Qty 4)

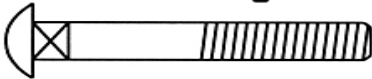

#11 M8 x 2" Carriage Bolt (Qty 4)



#28 M8 x 1" Allen Bolt (Qty 6)



#17 M5 x  $\frac{5}{8}$ " Philips Screw (Qty 2)



#21 M8 x  $\frac{3}{4}$ " Allen Bolt (Qty 10)

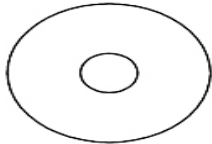

#31  $\varnothing$  1  $\frac{1}{4}$ " Large Black Washer (Qty 2)



#24  $\varnothing$   $\frac{5}{8}$ " Curved Washer (Qty 12)



#7  $\varnothing$   $\frac{5}{8}$ " Lock Washer (Qty 12)



#22  $\varnothing$   $\frac{5}{8}$ " Flat Washer (Qty 6)



#23 M8 Aircraft Nut (Qty 2)



#37 M8 Acorn Nut (Qty 8)

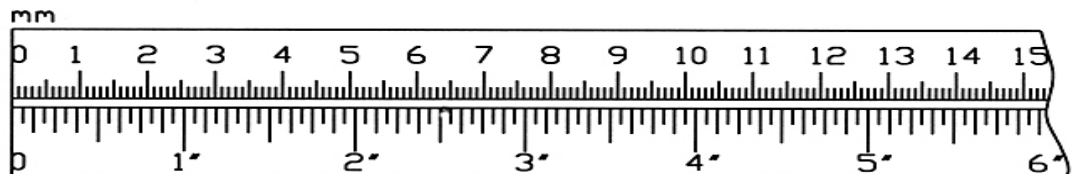

# ASSEMBLY INSTRUCTION

**NOTE:** It is strongly recommended that two or more people assemble this machine to avoid possible injury.

## STEP 1 (See Diagram1)

- A.) **Do not tighten the Nuts and Bolts until instructed to do so.**
- B.) Attach the Front Stabilizer (#39) to the Main Frame (#32). Secure it with two M8 x 2 ½" Carriage Bolts (#35), two Ø 5/8" Curved Washers (#24), and two M8 Acorn Nuts (#37).
- C.) Attach the Rear Stabilizer (#36) to the Main Frame. Secure it with two M8 x 2 ½" Carriage Bolts (#35), two Ø 5/8" Curved Washers (#24), and two M8 Acorn Nuts (#37).
- D.) **Securely tighten all Nuts and Bolts installed.**

**DIAGRAM 1**

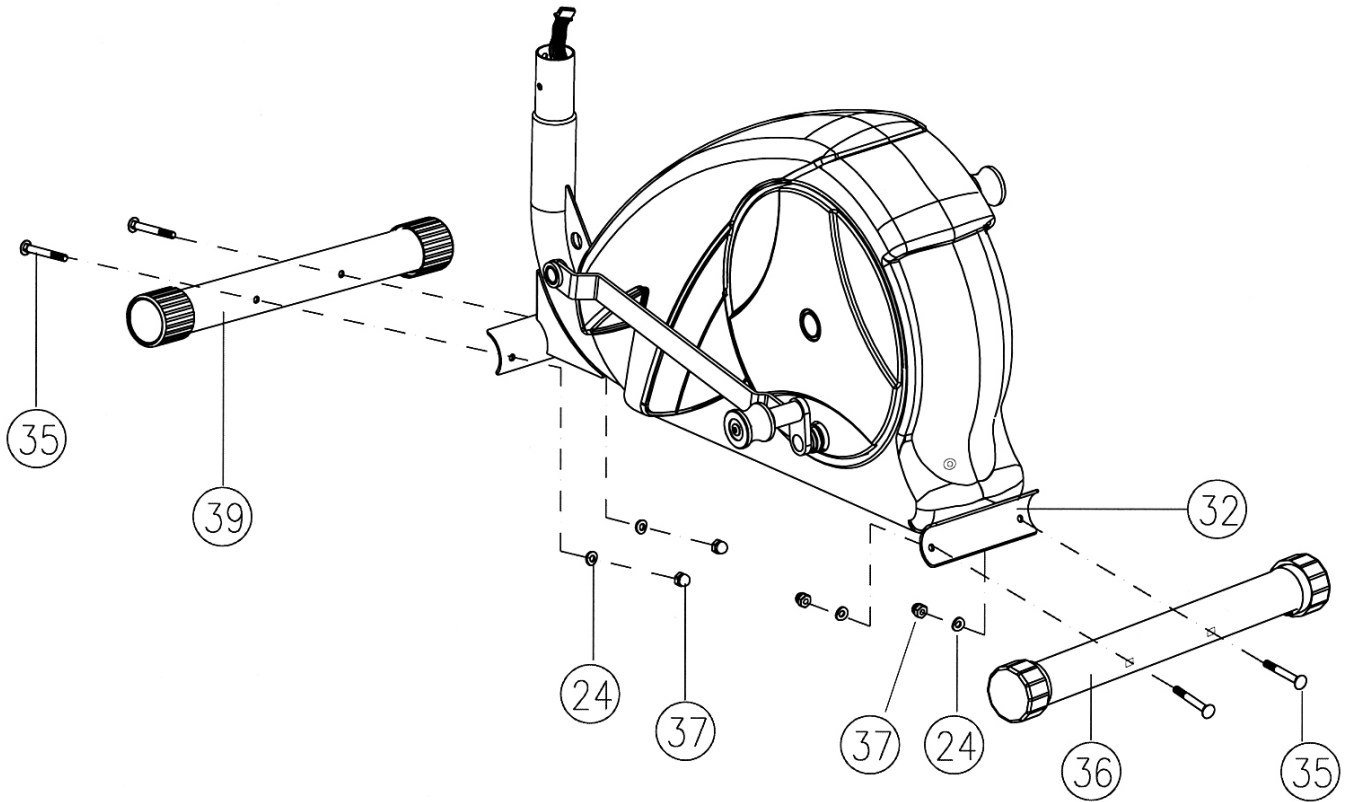

**STEP 2 (See Diagram 2)**

- A.) **Note: Extra help may be needed to hold the Front Post (#42) while connecting the computer wires.**
- B.) Connect the Upper Computer Wire (#91) from the bottom of Front Post to the Lower Computer Wire (#92) from the main Frame (#32).
- C.) Attach the Front Post to Main Frame. Secure them together with four M8 x 3/4" Allen Bolts (#21), four Ø 5/8" Lock Washers (#7), and four Ø 5/8" Curved Washers (#24).

**DIAGRAM 2**

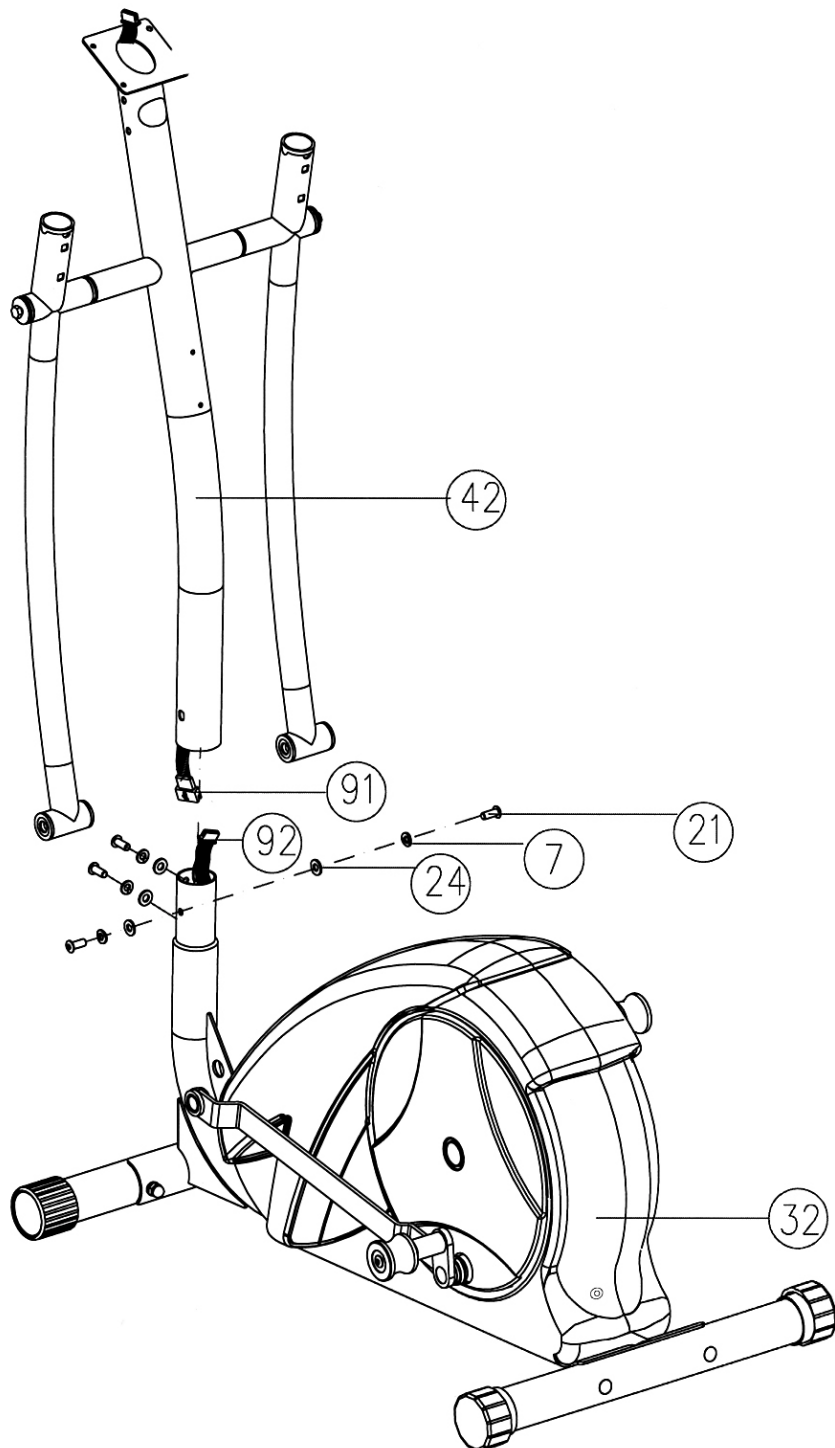

### STEP 3 (See Diagram 3)

- A.) **Note: In order to install the Pedal Supports (#30 & #38), extra help may be needed.**
- B.) **Do not tighten Nuts and Bolts until instructed to do so.**
- C.) Attach the Left Pedal Support (#38) onto the groove on left Roller Wheel (#49).
- D.) Insert the pivot on Left Pedal Support into the hole on the left Connecting Bracket (#54).  
Secure it with one M8 x ¾" Allen Bolt (#21) and one Ø 1 ¼" Large Black Washer (#31).
- E.) Attach the Left Connecting Rod (#41) onto the bracket on Left Pedal Support. Secure the Left Connecting Rod to the Left Pedal Support with one 3 ¼" Axle (#19), one Ø 5/8" Flat Washer (#22), and one M8 Aircraft Nut (#23).
- F.) Repeat C to E to install the Right Connecting Rod (#15) and Right Pedal Support (#30).
- G.) **Securely tighten all Nuts and Bolts installed.**

### DIAGRAM 3

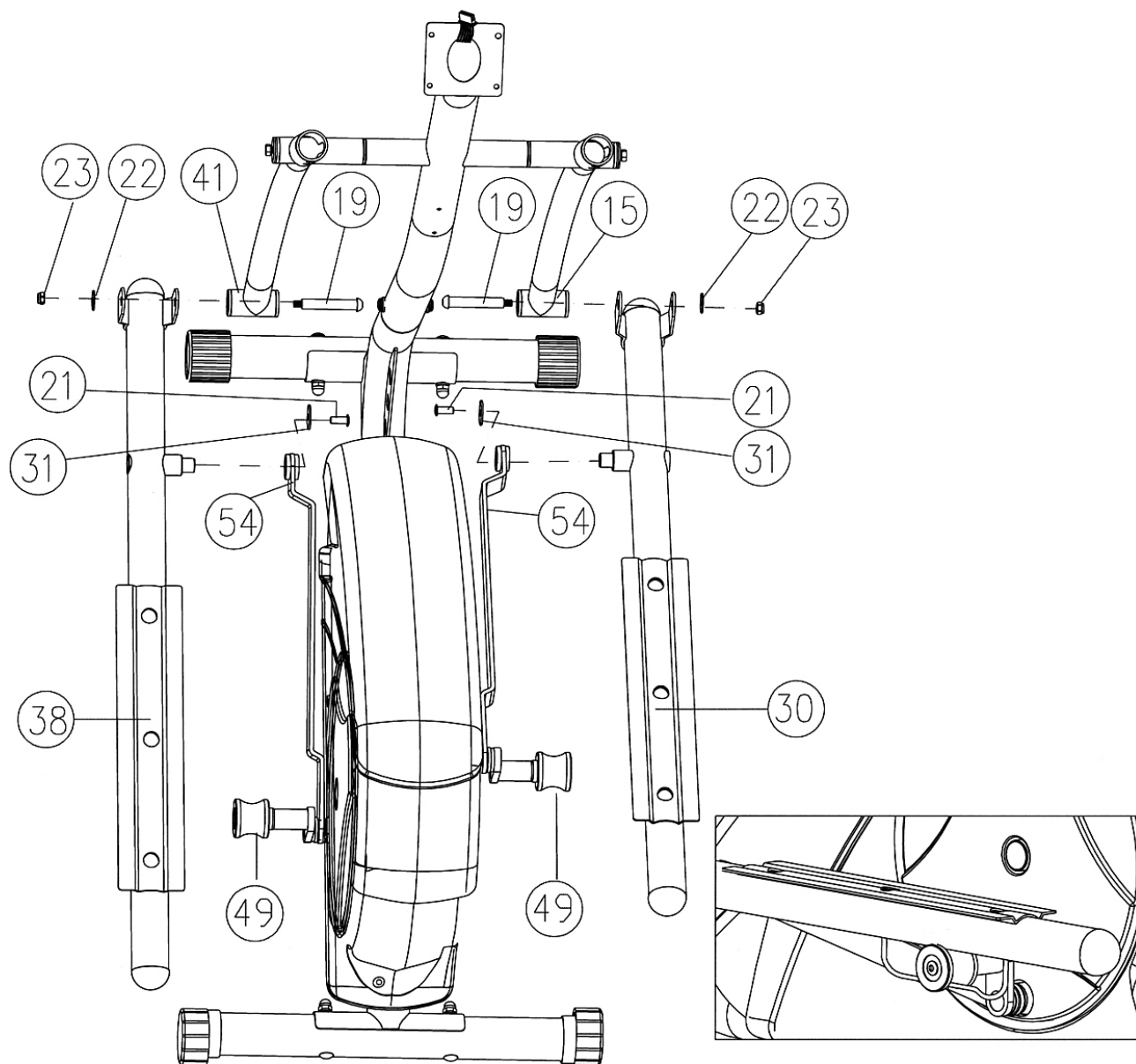



**STEP 4 (See Diagram 4)**

- A.) Cover the heads of the two M8 x 3/4" Hex Bolts (#6) pre-installed by factory with two M8 Nut Caps (#5).
- B.) Cover the two M8 Aircraft Nuts (#23) installed in Step-3 with two M8 Nut Caps (#5).

**DIAGRAM 4**

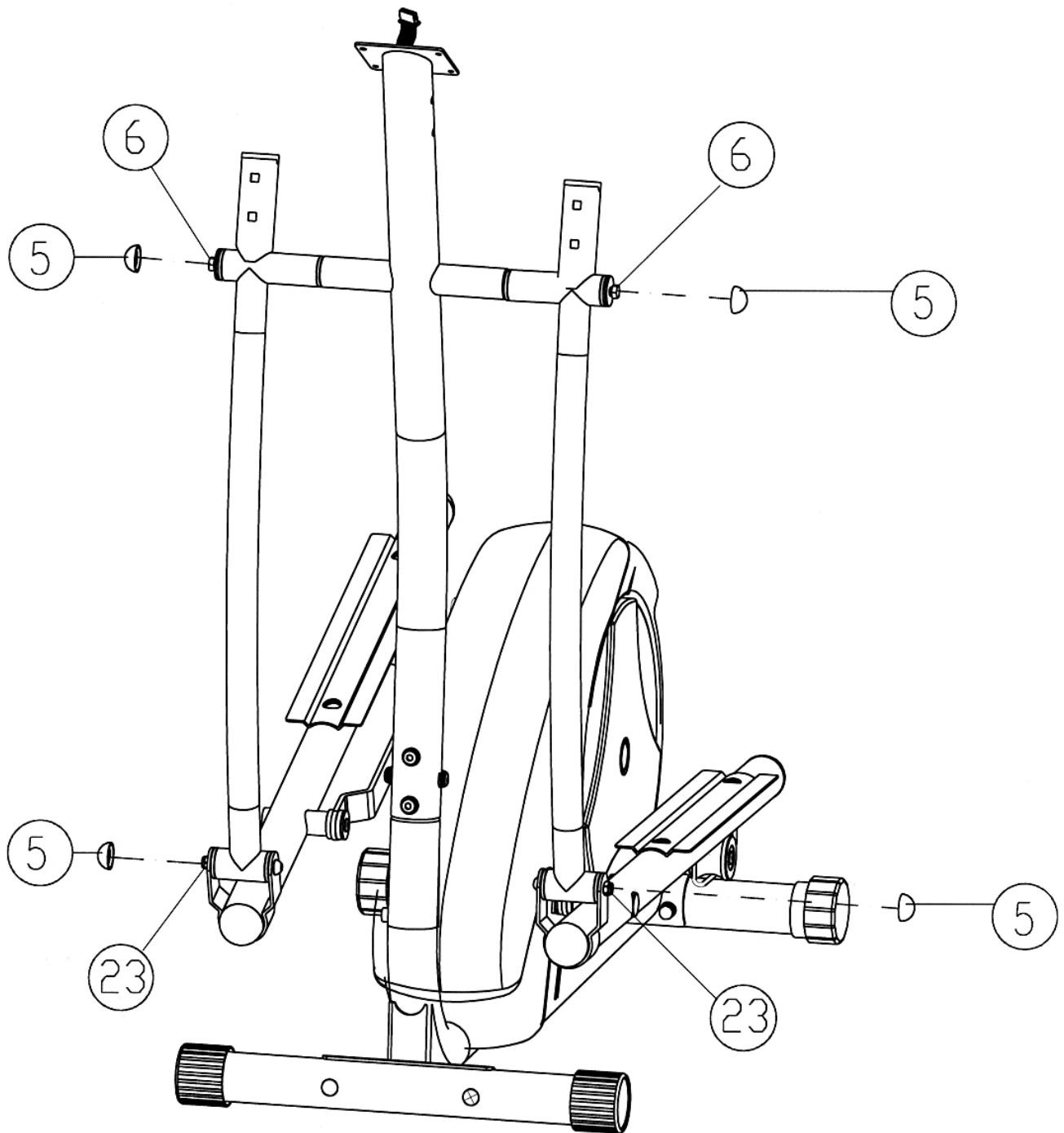

**STEP 5 (See Diagram 5)**

A.) Attach the two Pedals (#29) onto the Left & Right Pedal Support (#38 & #30). Secure each Pedal with three M8 x 1" Allen Bolts (#28).

**DIAGRAM 5**

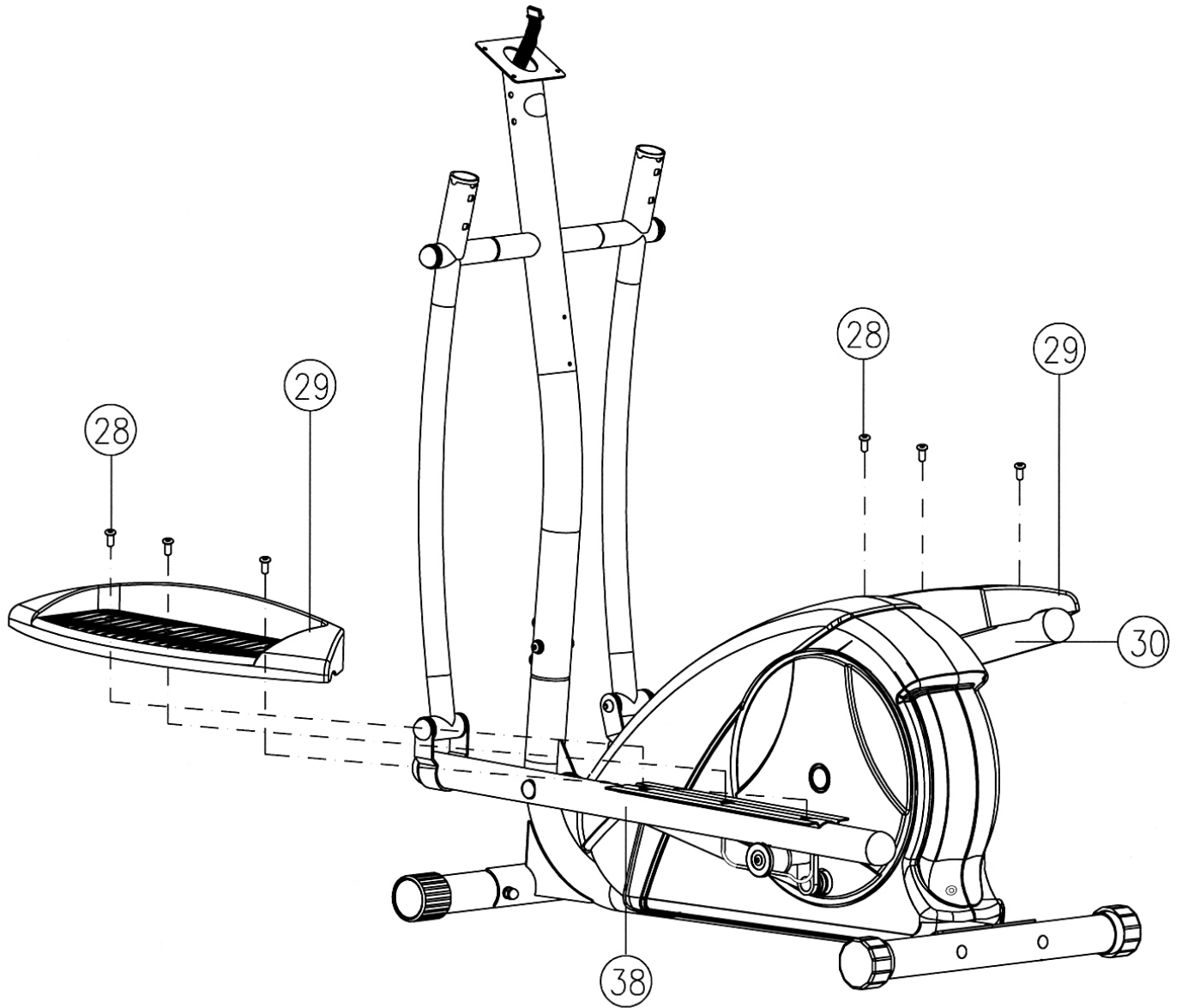

**STEP 6 (see Diagram 6)**

- A.) Insert the Right Stride Handle (#2) into the Right Connecting Rod (#15). Insert the Left Stride Handle (#44) into the Right Connecting Rod (#41).
- B.) Securely tighten each Handle with two M8 x 2" Carriage Bolts (#11), two Ø 5/8" Curved Washers (#24), two Ø 5/8" Lock Washers (#7), and two M8 Acorn Nuts (#37).

**DIAGRAM 6**

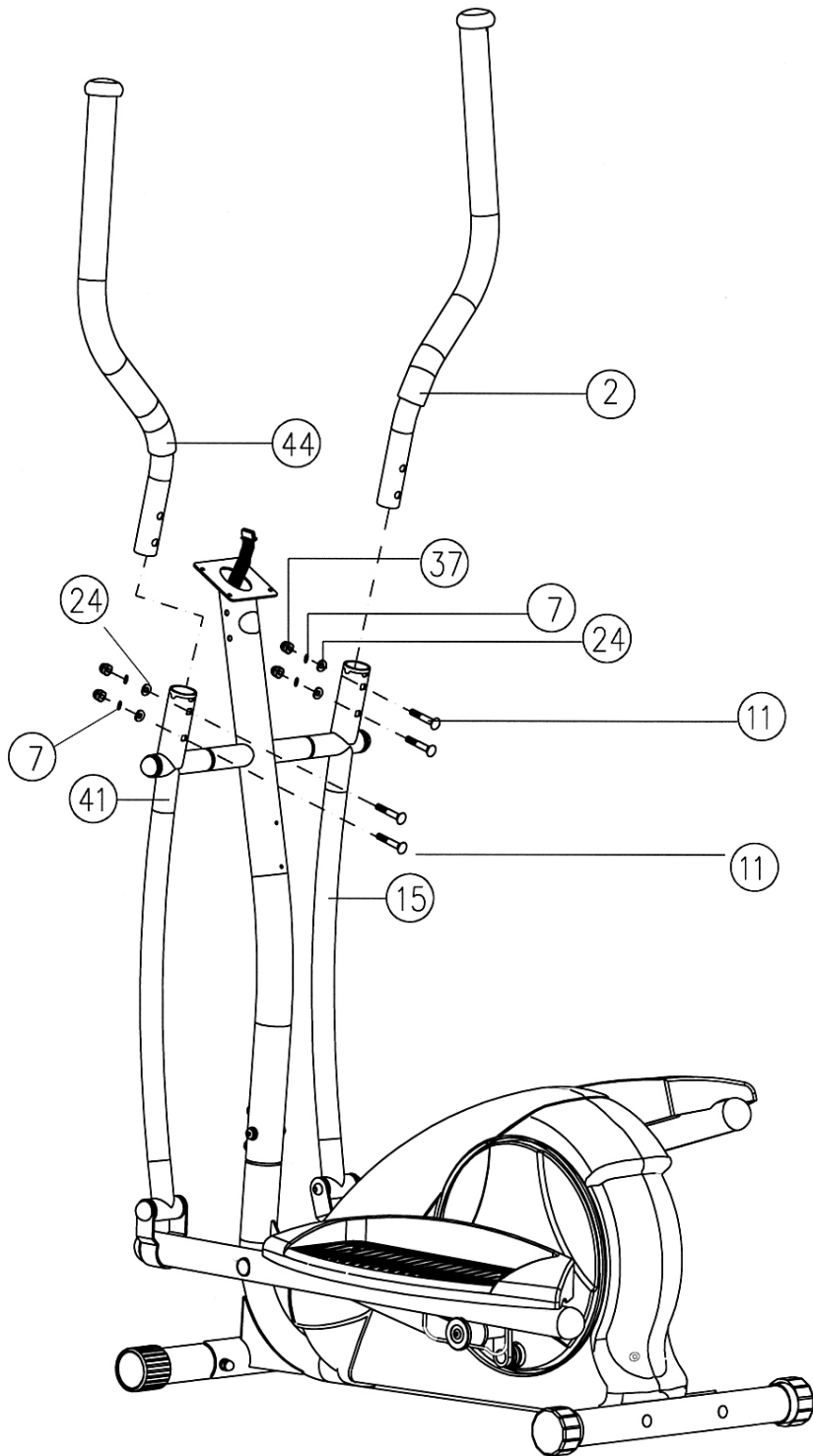

**STEP 7 (See Diagram 7)**

- A.) Attach the Water Bottle Rack (#18) to the Front Post (#42). Secure it with two M5 x 5/8" Philips Screws (#17).
- B.) Store the Water Bottle (#14) in the Rack.

**DIAGRAM 7**

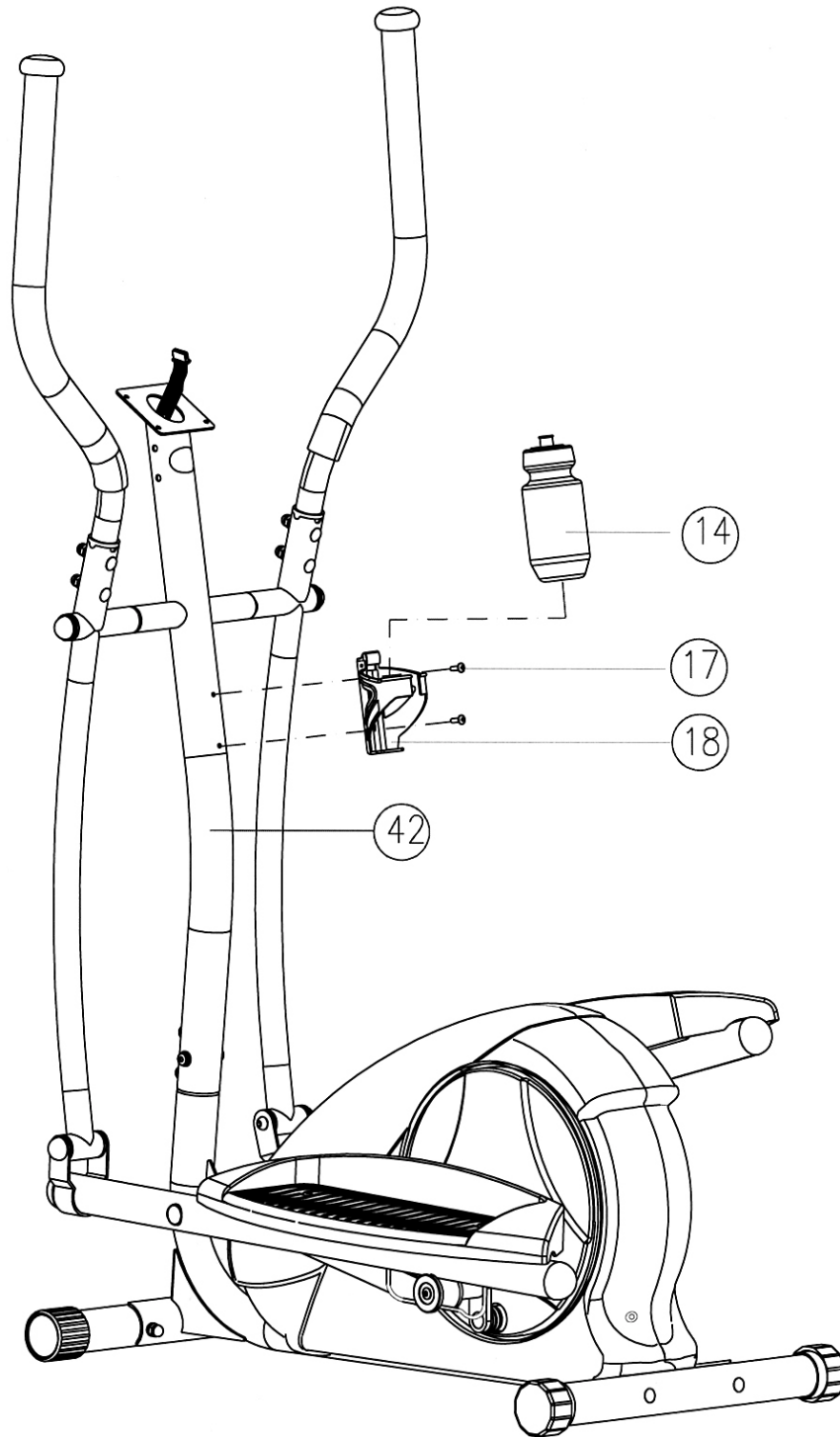

## STEP 8 (See Diagram 8)

A.) Attach the Stationary Handle (#27) to Front Post (#42). Secure it with four M8 x 3/4" Allen Bolts (#21), four Ø 5/8" Lock Washers (#7), and four Ø 5/8" Flat Washers (#22).

### DIAGRAM 8

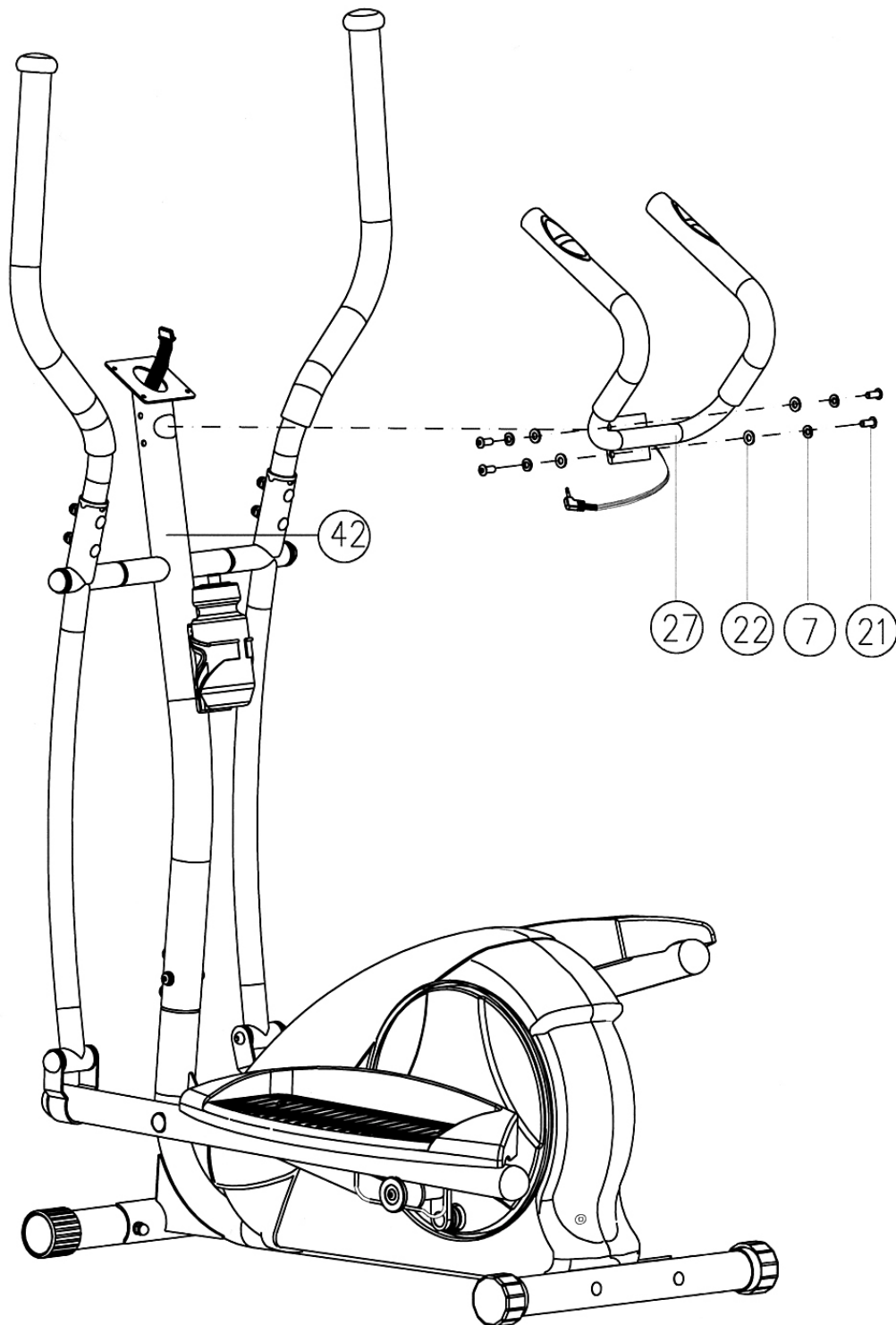

## STEP 9 (See Diagram 9)

- A.) Remove the four M5 x 5/8" Computer Philips Screws (#43) from the Computer (#45).
- B.) Connect the Upper Computer Wire (#91) to the wire on Computer.
- C.) Plug the sensor wire (#93) on the Front Post (#42) into the Computer.
- D.) Attach the Computer to the bracket on Front Post. Secure it with the four (removed previously) M5 x 5/8" Computer Philips Screws (#43).

### DIAGRAM 9

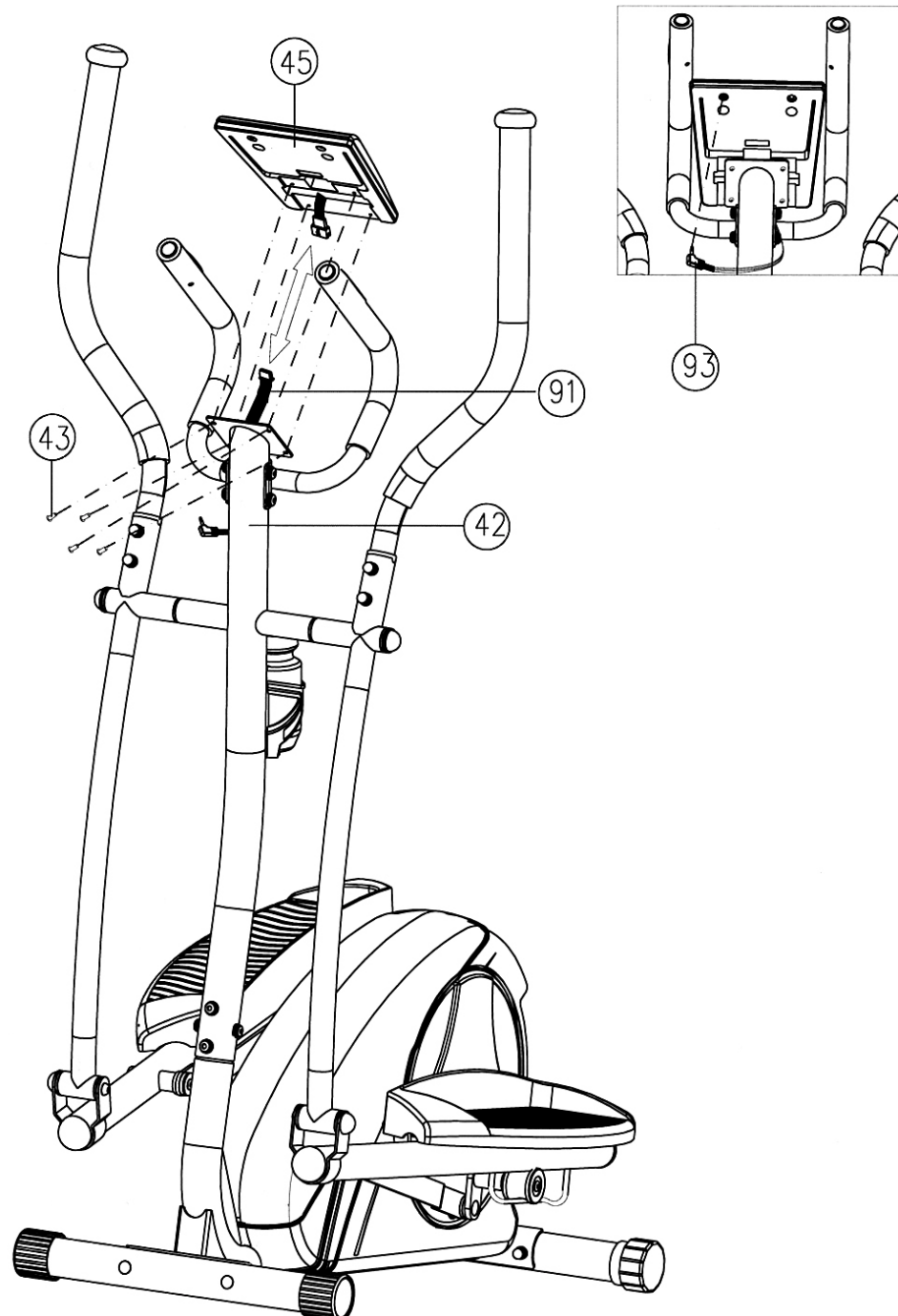

**STEP 10 (See Diagram 10)**

A.) Plug the AC Adapter (#34) to 110v outlet, and plug the power cord into the Main Frame (#32). **Note: Only use the original AC Adapter from manufacturer. Do not use any Adapter which is not from manufacturer.**

**DIAGRAM 10**

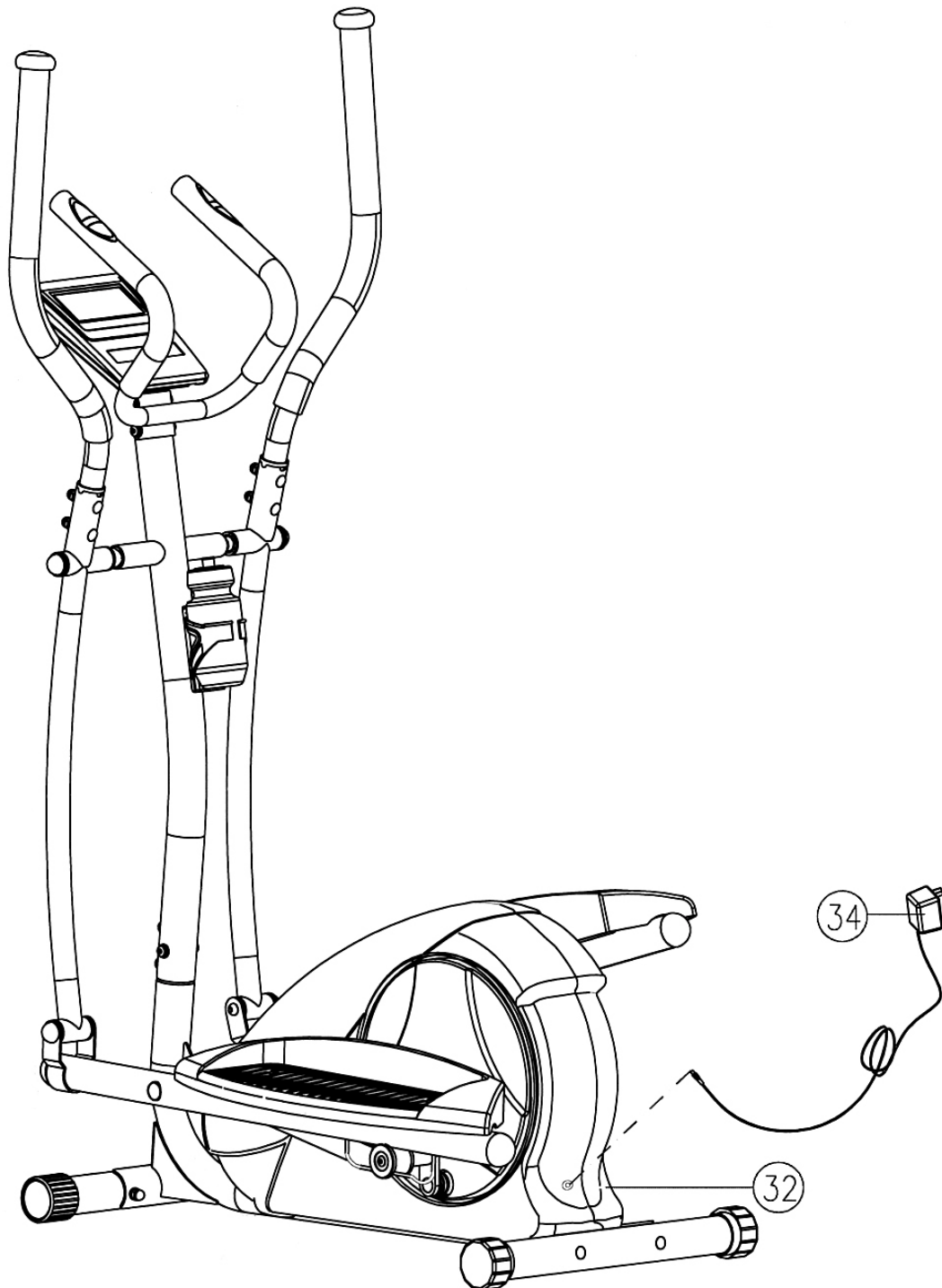

# EXPLDOED DIAGRAM

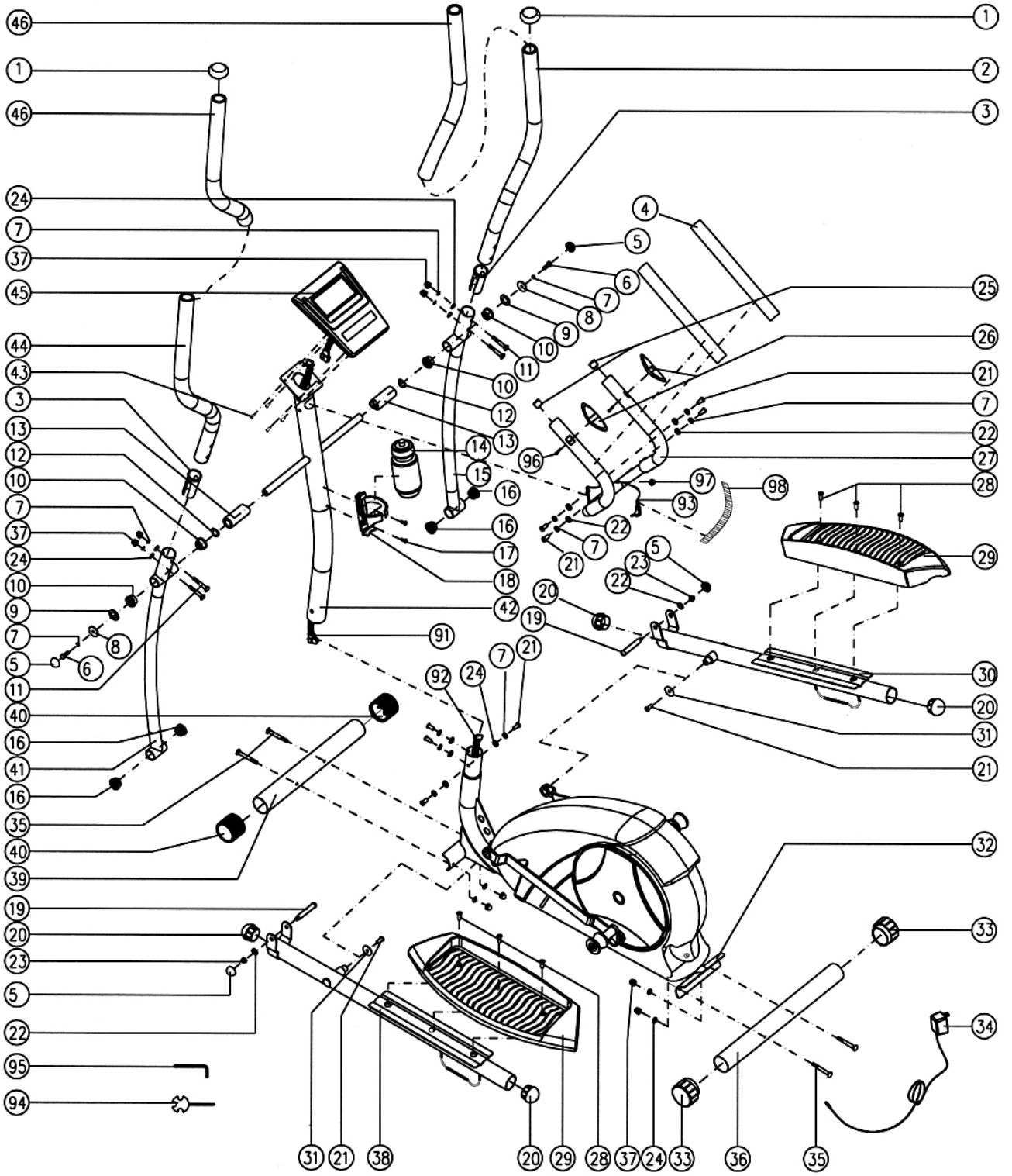



# EXPLODED DIAGRAM

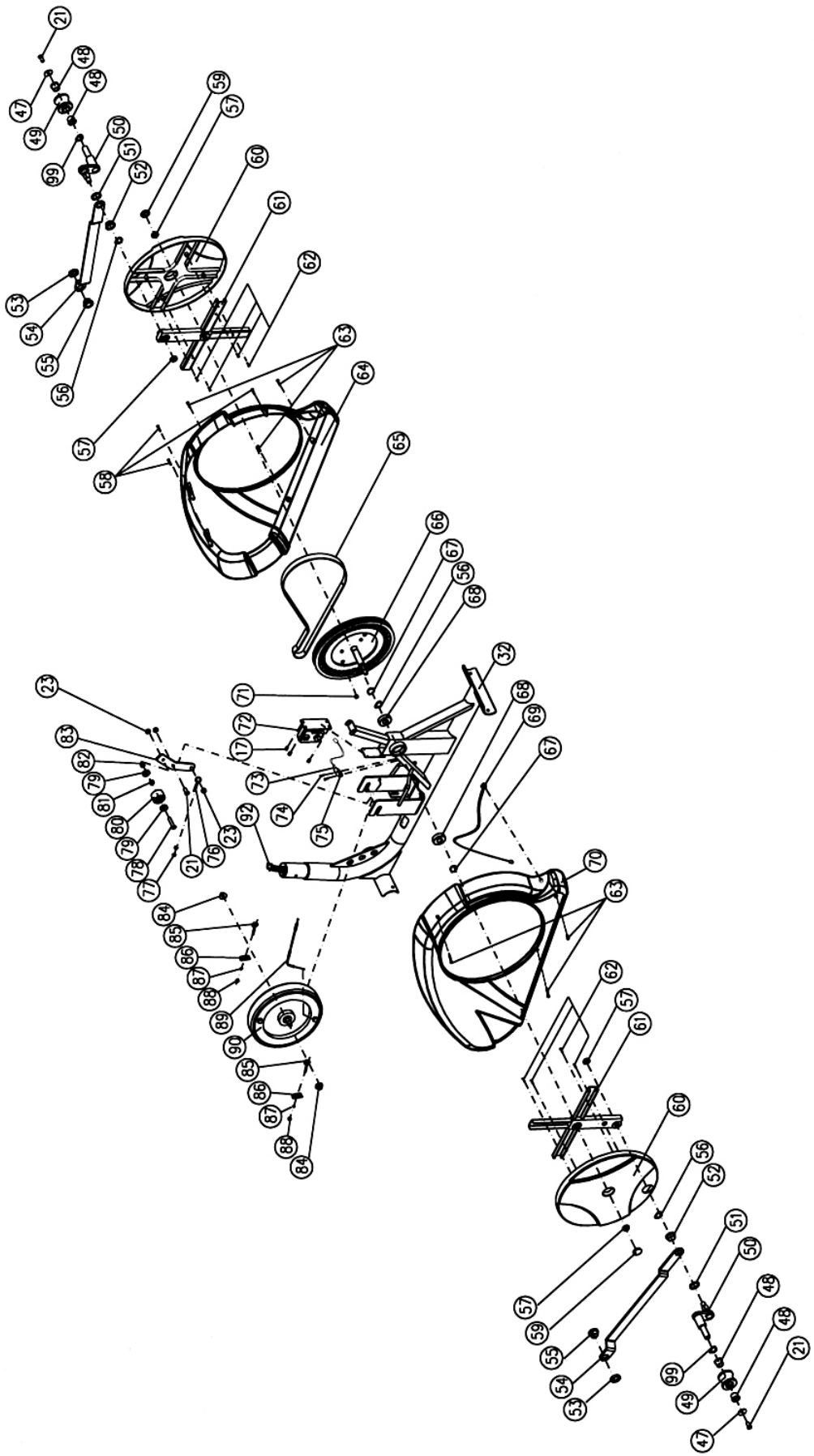

# PARTS LIST

KEY NO.	DESCRIPTION	Q'ty			
1	Stride Handle Cover Cap	2	51	Ø 1 1/8" x Ø 7/8" Spacer	2
2	Right Stride Handle	1	52	Ø 1 1/8" x 1/2" Bushing	2
3	Ø 1 1/2" Stride Handle Bushing	2	53	Ø 1 1/8" x 1/4" Spacer	2
4	Stationary Handle Grip	2	54	Connecting Bracket	2
5	M8 Nut Cap	4	55	Ø 1 1/8" x 5/8" Bushing	2
6	M8 x 3/4" Hex Bolt	2	56	Ø 3/4" Black Curved Washer	3
7	Ø 5/8" Lock Washer	14	57	M12 Hex Nut	4
8	Ø 1 1/4" Large Flat Zinc Washer	2	58	ST4.2 x 1" Philips Self-tapping Screw	3
9	Plastic Ring	2	59	M25 Nut Cap	2
10	Ø 1 1/4" x Ø 3/4" Bushing	1	60	Side Fly Wheel	2
11	M8 x 2" Carriage Bolt	4	61	Fly Wheel Mounting Frame	2
12	Ø 3/4" Curved Washer	2	62	ST4.2 x 5/8" Philips Screw	8
13	Ø 1 1/4" x 2 7/8" Upper Bushing	2	63	STE4.2 x 1" Philips Screw	6
14	Water Bottle	1	64	Right Shroud	1
15	Right Connecting Rod	1	65	Belt	1
16	Ø 1 1/4" x Ø 1/2" Bushing	4	66	Middle Fly Wheel	1
17	M5 x 5/8" Philips Screw	5	67	Ø 3/4" Black Lock Washer	2
18	Water Bottle Rack	1	68	600ZZ Ball Bearing	2
19	3 1/4" Axle	2	69	Power Cord	1
20	Ø 1 3/4" Con-shaped End Cap	4	70	Left Shroud	1
21	M8 x 3/4" Allen Bolt	13	71	Magnet	1
22	Ø 5/8" Flat Washer	6	72	Motor	1
23	M8 Aircraft Nut	5	73	Sensor Wire	1
24	Ø 5/8" Curved Washer	12	74	ST4.2 x 3/4" Self-tapping Screw	2
25	Ø 1" End Cap	2	75	Sensor Base	1
26	Pulse Sensor	2	76	M8 x 3 1/8" Bolt	1
27	Stationary Handle	1	77	M8 Hex Nut	2
28	M8 x 1" Allen Bolt	6	78	M8 x 1 5/8" Allen Bolt	1
29	Pedal	2	79	608ZZ Ball Bearing	2
30	Right Pedal Support	1	80	Ø 1 1/8" x 1/4" Sleeve	1
31	Ø 1 1/4" Large Black Washer	2	81	Ø 1/2" x 5/8" Spacer	1
32	Main Frame	1	82	Ø 1/2" x 1/8" Spacer	1
33	Rear Stabilizer	2	83	Wheel Bracket	1
34	AC Adapter	1	84	M10 Flange Nut	2
35	M8 x 2 1/2" Carriage Bolt	4	85	M6 Bolt	2
36	Rear Stabilizer	1	86	U-shaped Bracket	2
37	M8 Acorn Nut	8	87	Ø 1/2" Lock Washer	2
38	Left Pedal Support	1	88	M6 Hex Nut	2
39	Front Stabilizer	1	89	Tension Cable	1
40	Front Stabilizer Roller Cap	2	90	Magnetic Controlled Wheel	1
41	Left Connecting Rod	1	91	Upper Computer Wire	1
42	Front Post	1	92	Lower Computer Wire	1
43	M5 x 5/8" Computer Philips Screw	4	93	Pulse Sensor Wire	1
44	Left Stride Handle	1	94	Crossing Wrench (Tool)	1
45	Computer	1	95	#6 Allen Wrench (Tool)	1
46	Handle Foam Grip	2	96	M5 x 3/8" Philips Screw	2
47	Ø 7/8" Large Black Washer	2	97	Ø 3/8" End Cap	1
48	Ø 1" x 5/8" Wheel Bushing	4	98	Wire Sleeve	1
49	Roller Wheel	2	99	Ø 7/8" Curved Washer	2
50	Crank	2			

# IMPEX<sup>®</sup> INC.

## LIMITED WARRANTY

IMPEX Inc. ("IMPEX<sup>®</sup>") warrants this product to be free from defects in workmanship and material, under normal use and service conditions, for a period of two years on the Frame from the date of purchase. This warranty extends only to the original purchaser. IMPEX's obligation under this Warranty is limited to replacing or repairing, at IMPEX's option.

All returns must be pre-authorized by IMPEX. Pre-authorization may be obtained by calling IMPEX Customer Service Department at 1-800-999-8899. All freights for products return to IMPEX must be prepaid by the customer. This warranty does not extend to any product or damage to a product caused by or attributable to freight damage, abuse, misuse, improper or abnormal usage or repairs not provided by an IMPEX authorized service center or for products used for commercial or rental purposes. No other warranty beyond that specifically set forth above is authorized by IMPEX.

IMPEX is not responsible or liable for indirect, special or consequential damages arising out of or in connection with the use or performance of the product or other damages with respect to any economic loss, loss of property, loss of revenues or profits, loss of enjoyments or use, costs of removal, installation or other consequential damages or whatsoever natures. Some states do not allow the exclusion or limitation of incidental or consequential damages. Accordingly, the above limitation may not apply to you.

The warranty extended hereunder is in lieu of any and all other warranties and any implied warranties of merchantability or fitness for a particular purpose is limited in its scope and duration to the terms set forth herein. Some states do not allow limitations on how long an implied warranty lasts. Accordingly, the above limitation may not apply to you.

This warranty gives you specific legal right. You may also have other rights which vary from state to state. Register on-line [www.impex-fitness.com](http://www.impex-fitness.com)

**IMPEX<sup>®</sup> INC.**  
**14777 Don Julian**  
**City of Industry, CA 91746**

### **ORDERING REPLACEMENT PARTS**

Replacement parts can be ordered by calling our Customer Service Department toll-free at **1-800-999-8899** during our regular business hours: Monday through Friday, 9 am until 5 pm Pacific standard time.

**[info@impex-fitness.com](mailto:info@impex-fitness.com)**

When ordering replacement part, always give the following information.

1. Model
2. Description of Parts
3. Part Number
4. Date of Purchase