

IMPORTANT! In U.S. and Canada only: Have questions? ...don't go back to the store!

We appreciate your purchasing one of our many fine products. We are sure that you will be very satisfied with your selection. Although great care and effort have been taken, occasionally problems may occur. To ensure prompt and correct handling of any problems, or to answer any questions, please contact our Toll-Free Customer Service Number listed below. Service will be quicker if you have your Model Number (found on carton) and assembly instructions ready when calling. PLEASE WRITE YOUR MODEL NUMBER IN THE SPACE PROVIDED ABOVE.

SAFETY INSTRUCTIONS

FAILURE TO FOLLOW THESE SAFETY INSTRUCTIONS MAY RESULT IN SERIOUS INJURY, PROPERTY DAMAGE AND VOID WARRANTY.

Owner must ensure that all players know and follow these rules for safe operation of the system.

To ensure safety, do not attempt to assemble this system without following the instructions carefully. Proper and complete assembly, use and supervision is essential for proper operation and to reduce the risk of accident or injury. A high probability of serious injury exists if this system is not installed, maintained, and operated properly. Check entire box and inside all packing material for parts and/or additional instructional material. Before beginning assembly, read the instructions and identify parts using the hardware identifier and parts list in this document.

- If using a ladder during assembly, use extreme caution.
- Two (2) people are recommended for this operation.
- Check base regularly for leakage. Slow leaks could cause system to tip over unexpectedly.
- Seat the pole sections properly (if applicable). Failure to do so could allow the pole sections to separate during play and/or transport of the system.
- Climate, corrosion or misuse could result in system failure.
- Minimum operational height is 6' 6" (1.98 m) to the bottom of backboard.
- This equipment is intended for home recreational use only and NOT excessive competitive play.
- Read and understand the warning label affixed to pole. Label is shown on page 1.
- The life of your basketball pole depends on many conditions. The climate, placement of the pole, the location of the pole, exposure to corrosives such as pesticides, herbicides or salts are all important.
- If technical assistance is required, contact Huffy Sports.
- Adult supervision is recommended when adjusting height.

Most injuries are caused by misuse and/or not following instructions. Use caution when using this system.

For more information on assembly, placement, proper use and maintenance, visit The American Basketball Council website at <http://www.smarthoops.com>.

The NBA and individual NBA member team identifications reproduced on this product are trademarks and copyrighted designs, and/or other forms of intellectual property, that are the exclusive property of NBA Properties, Inc. and the respective NBA member teams and may not be used, in whole or in part, without the written consent of NBA Properties, Inc.

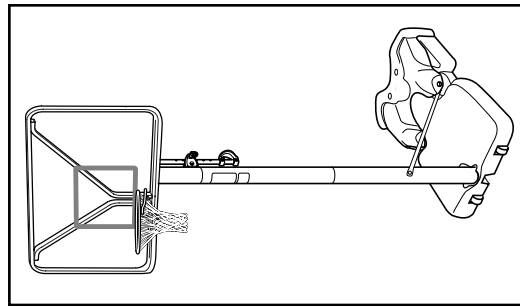

NOTICE TO ASSEMBLERS
All Huffy Sports basketball Systems, including those used for **DISPLAYS**, **MUST** be assembled and ballasted with sand or water according to instructions. Failure to follow instructions could result in **SERIOUS INJURY**. It is **NOT** acceptable to devise a makeshift weight system.

21

HEIGHT ADJUSTMENT

TO ADJUST BACKBOARD:

1. While holding handle, remove pin.
2. Move elevator up or down to desired height.
3. Replace pin full length to lock system at desired height.

MOVING SYSTEM

1. Adjust basketball backboard height to lowest position.
2. While holding pole, rotate basketball system forward until wheels engage with ground.
3. Move basketball system to desired location.
4. Carefully rotate basketball system upright.
5. Reattach ground restraint and check system for stability.

WARNING

FAILURE TO FOLLOW THESE WARNINGS MAY RESULT IN SERIOUS INJURY AND/OR PROPERTY DAMAGE.

Owner must ensure that all players know and follow these rules for safe operation of the system.

- DO NOT HANG on the rim or any part of the system including backboard, support braces or net.
- During play, especially when performing dunk type activities, keep player's face away from the backboard, rim and net. Serious injury could occur if teeth/faces come in contact with backboard, rim or net.
- Do not slide, climb, shake or play on base and/or pole.
- After assembly is complete, fill system completely with water or sand and stake to the ground. Never leave system in an upright position without filling base with weight, as system may tip over causing injuries.
- When adjusting height or moving system, keep hands and fingers away from moving parts.
- Do not allow children to move or adjust system.
- During play, do not wear jewelry (rings, watches, necklaces, etc.). Objects may entangle in net.
- Surface beneath the base must be smooth and free of gravel or other sharp objects. Punctures cause leakage and could cause system to tip over.
- Keep organic material away from pole base. Grass, litter, etc. could cause corrosion and/or deterioration.
- Check pole system for signs of corrosion (rust, pitting, chipping) and repaint with exterior enamel paint. If rust has penetrated through the steel anywhere, replace pole immediately.
- Check system before each use for proper ballast, loose hardware, excessive wear and signs corrosion and repair before use.
- Check system before each use for instability.
- Do not use system during windy and/or severe weather conditions: system may tip over. Place system in the storage position and/or in an area protected from the wind and free from personal property and/or overhead wires.
- Never play on damaged equipment.
- See instruction manual for proper installation and maintenance.
- When moving system, use caution to keep mechanism from shifting.
- Keep pole top covered with cap at all times.
- Do not allow water in tank to freeze. During sub-freezing weather add non-toxic antifreeze, sand or empty tank completely and store. (Do not use salt.)
- Use extreme caution if placing system on sloped surface. System may tip over more easily.

HUFFY SPORTS

In the U.S.: 1-800-558-5234 and Canada: 1-800-284-8339

201241 2/99

Toll-Free Customer Service Number for U.S.: 1-800-558-5234, For Canada: 1-800-284-8339, For Europe: 00 800 555 85234 (Sweden: 009 555 85234), For Australia: 1-800-333 061 - Internet Address: <http://www.huffysports.com>

HARDWARE IDENTIFIER



Item #2 (2)



Item #7 (1)

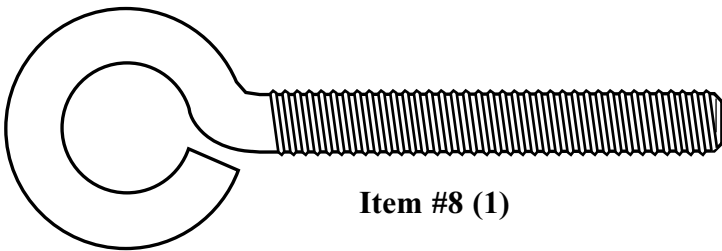

Item #8 (1)

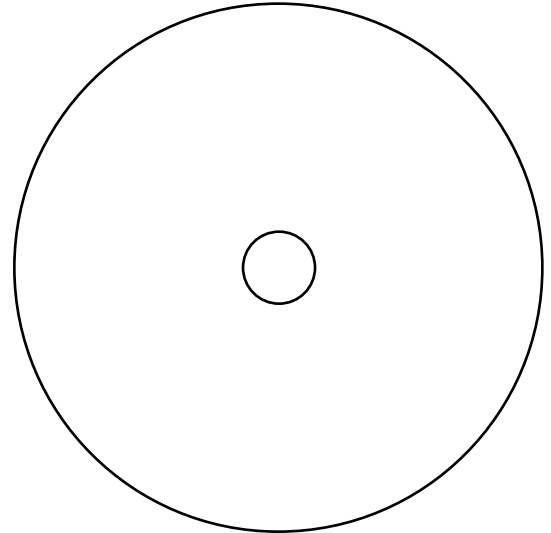

Item #9 (1)

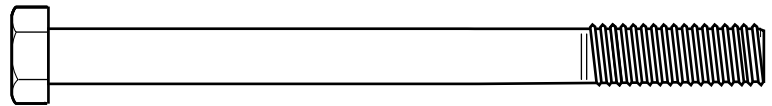

Item #10 (1)

Item #12 (1)

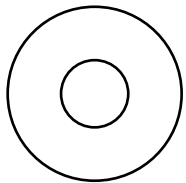

Item #13 (6)

Item #14 (1)



Item #15 (3)

Item #16 (7)*

* You may have extra parts with this model

HARDWARE IDENTIFIER (CONTINUED)

HARDWARE IDENTIFIER (CONTINUED)

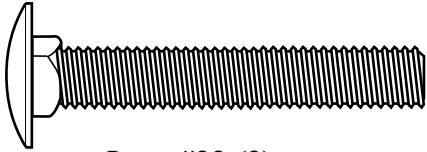

Item #22 (2)

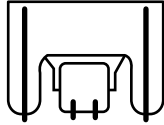

Item #23 (12)*

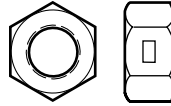

Item #24 (1)

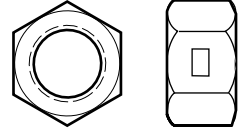

Item #25 (3)

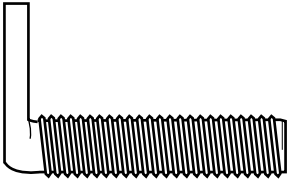

Item #28 (4)*

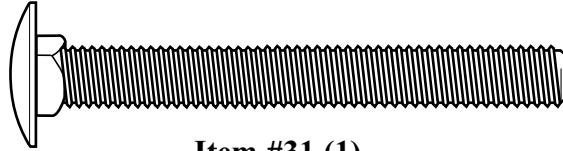

Item #31 (1)

Item #32 (2)

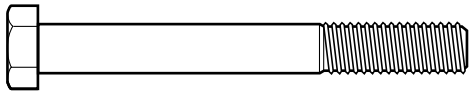

Item #33 (1)

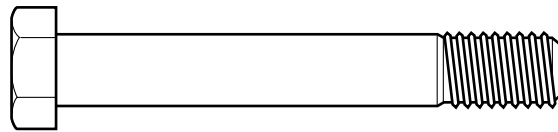

Item #34 (3)

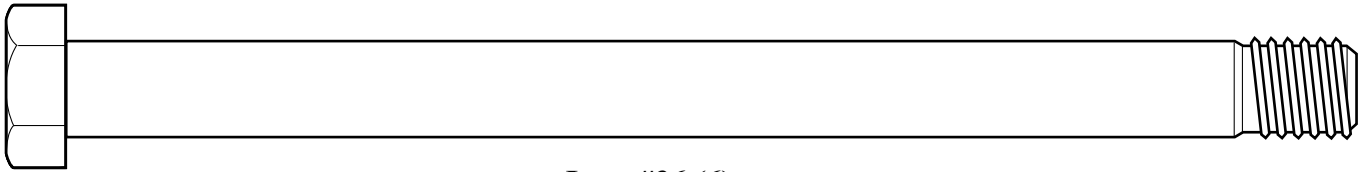

Item #36 (6)

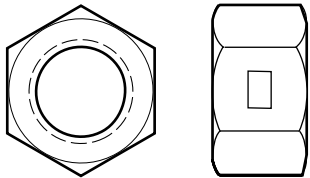

Item #37 (6)

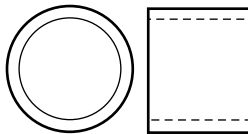

Item #38 (8)

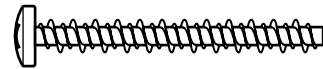

Item #42 (1)

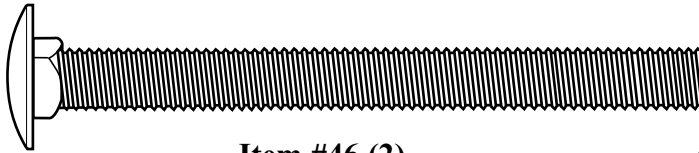

Item #46 (2)



Item #47 (2)

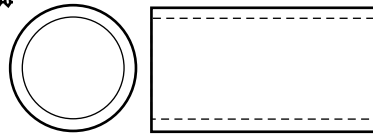

Item #56 (4)

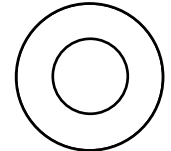

Item #49 (4)

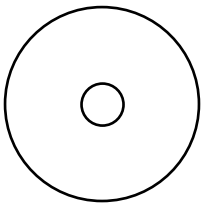

Item #58 (6)

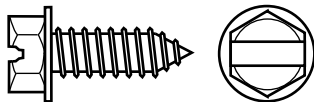

Item #59 (6)



Item #60 (2)



Item #61 (2)



Item #62 (4)

* You may have extra parts with this model.

ENGLISH INSTRUCTIONS

IMPORTANT! WRITE MODEL NUMBER FROM BOX ONTO PAGE 1 OF THIS OWNERS MANUAL

1. Remove all contents from tank (1).
2. Turn tank (1) bottom side up. Insert axle rod (2) through wheel (3), as shown. Secure wheel assembly to tank by tapping wheel assembly downward with hammer. It will snap into position. Repeat for opposite side, then carefully, turn tank over.
3. Correctly identify each pole section and mark indicated distance from ends with tape as shown.
4. **IMPORTANT! Center alignment slot of middle pole section (4) in a lower hole of top pole section (5) as shown.** While maintaining alignment, bounce pole top (5) and middle section (4) together as shown until they no longer move toward taped reference mark. Upright assembly. **NOTE:** Pole sections should have a 3-1/2" (9 cm) minimum overlap.
5. **IMPORTANT! Center alignment slot of lower pole section (6) in a lower hole of middle pole section (4) as in step 4.** While maintaining alignment, bounce assembly and lower section (6) together as shown until they no longer move toward taped reference mark. **NOTE:** Pole sections should have a 3-1/2" (9 cm) minimum overlap.
6. Install rod (7) through holes in bottom pole section (6) and eyebolt (8).
7. Insert pole assembly into tank assembly as shown.
8. Carefully place unit on its side, and secure pole bottom (6) to tank as shown, a deep socket is recommended. Upright unit. **NOTE:** Keep unnecessary pressure off of the pole assembly when in this position. Two people recommended for this procedure. **IMPORTANT! Do not over tighten.**
9. Secure tank struts (11) to pole. Rotate non-secured ends of tank struts (11) outward to cups in tank as shown.
▲ WARNING: TIGHTEN BOLT (12) IN LOCKNUT (14) UNTIL FLUSH (EVEN) WITH LOCKNUT'S OUTER EDGE.
10. Secure non-secured ends of tank struts (11) to tank as shown. Repeat for opposite side.
11. Install pole mount bracket (45), bracket reinforcement (54) with carriage bolts (46) as shown. Tighten flange nuts (16) completely.
12. Attach spacers (47, 48) to pole mount bracket (45) with bolts (34), washers (49), and nuts (25) as shown. **IMPORTANT! Tighten until washers (49) no longer move.**
13. Attach covers (50) onto pole mount bracket (45) with carriage bolt (31) and nut (14) as shown.
IMPORTANT: Loop end of pin lanyard (30) over carriage bolt (31) during this assembly. NOTE: Assemble lanyard (30) to locking pin (27) as shown.
14. Apply logo and height indicator labels (44) to adjustment rod (43) as shown. Attach handle parts (40, 41) to adjustment rod with screw (42), carriage bolt (22), and flange nut (14) as shown. **IMPORTANT: Indicator labels should be applied as close to holes as possible to prevent labels from being damaged during height adjustment.**
NOTE: Holes in adjustment rod allow for either rear access or side access.
15. Insert handle assembly through pole mount assembly as shown. Lock pole assembly in place at the 10' (3.05 m) mark with pin (27).
16. Install spacers (32) onto backboard brackets (18) with bolts (33, 34) and lock-nuts (24, 25) as shown. **NOTE:** Test fit bolts into holes of brackets (18) and carefully rock them in a circular motion to ream out paint from holes if necessary.
17. Install net clips (23) to rim (26).
The Quick Clip™ rapid release net system lets the net pull away from the rim. This reduces the risk of player injury or property damage. However, improper installation or a ball making contact at an odd angle may disengage the net clip from the goal rim. Usually, the clip is reinstalled with little or no problem. We hope that you agree this inconvenience is minor when compared to the safety of the players. Quick Clip: US Patent No. 5,792,010/5,795,253
The two outer hooks on net clip must face towards inside of goal rim. Insert larger hole in net clip onto rim stud, push down on net clip, then slide net clip right, locking or snapping securely into position (clips must "snap" into place to insure a secure fit). **NOTE:** Net clips should not slide with ease. It is very important that the net clips are in the locked position before going on to next step.
- ▲ WARNING: USE OF THIS PRODUCT WITHOUT PROPER INSTALLATION OF NET CLIPS, OR WHEN ALL NET CLIPS ARE NOT PRESENT COULD RESULT IN BODILY HARM. BE SURE TO FOLLOW DIRECTIONS CAREFULLY.**
18. Assemble lower elevator tubes (35) and springs (51) as shown. Tighten completely.
IMPORTANT! It is necessary for all parts to be installed for this mechanism to work safely and properly.
19. Bend bracket (18) to line up with holes in backboard.
20. Starting with nuts (16) flush against bracket (18), secure rim (26) and bracket to backboard. **IMPORTANT! For spring loaded rim assembly, refer to instructions included with rim hardware. NOTE A:** Do not use washers here on spring return style rim. **NOTE B:** Mounting nuts and bolts supplied with rim hardware.
21. Assemble upper elevator tubes (39) to backboard brackets (18).
22. Support pole on sawhorse. Attach backboard assembly to top pole section (5). Then install pole cap (29). **NOTE:** Two people are recommended for this step. Use caution; elevator assembly is heavy.
23. Install handle assembly to lower elevator tubes (35) using bolt (36), spacers (38), and nut (37) as shown. **NOTE:** Before going on to next step, set adjustment system assembly to the 10' (3.05 m) setting.
24. Insert bolt (36) through left side upper elevator tube (39), then stretch spring (51) onto bolt (36). Insert bolt (36) through right side upper elevator tube (39) and secure with nut (37).
▲ WARNING: USE EYE PROTECTION WHEN INSTALLING SPRINGS.
25. Install net (52) as shown. **IMPORTANT! Make sure net is held by all three hooks on the net clip.**
NOTE: Stretching net up then pulling side to side will help snap net under center hook.
26. Loosely install hardware (58 and 59) into holes as shown in Figure B. Attach board pads (55, 56, 57) onto hardware and tighten completely. **NOTE: Do NOT overtighten.**
27. **NOTE:** Two people recommended for this procedure. Carefully upright assembly. Place assembled unit in desired location. Bend Wide Body (54) tank up and fill lower tank with water (30 gal., 114 liters or sand, 250 lbs., 113 kgs.) and snap tank cap (17) into place.
▲ WARNING: DO NOT LEAVE ASSEMBLY UNATTENDED WHEN EMPTY. SYSTEM MAY TIP OVER.
IMPORTANT! Add two gallons (7.6 liters) of NON-TOXIC ANTIFREEZE in sub-freezing climates.
28. Fill upper tank with water (10 gal., 38 liters or sand 100 lbs., 45 kgs.). Snap tank caps (17) into place. **IMPORTANT! Add one gallon (3.8 liters) of NON-TOXIC ANTIFREEZE in sub-freezing climates.**
29. Secure assembly to ground using rope (20), ground stake (19), bolt (15) and nut (16) as shown.
30. While holding handle, remove pin (27).
▲ WARNING: DO NOT ALLOW CHILDREN TO ADJUST HEIGHT.
31. Move elevator up or down to desired height.
32. Replace pin (27) full length to lock system at desired height.
33. Apply height and transport label (21) to front of pole as shown. Regulation rim height is 10 feet (3.05m).

PARTS LIST
(See Hardware Identifier)

<u>Item</u>	<u>Qty.</u>	<u>Part No.</u>	<u>Description</u>
1	1	206667	Tank
2	2	206327	Axle
3	2	226401	Wheel
4	1	908482	Middle Pole Section
5	1	904847	Top Pole Section
6	1	908003	Bottom Pole Section
7	1	202820	Rod, 3/8-16 x 4-3/4 Long
8	1	202822	Eyebolt, 3/8-16 x 3-3/4
9	1	202821	Disk, 2-3/4 O.D.
10	1	203063	Locknut, Nylon Insert, 3/8-16
11	2	906206	Strut, Tank
12	1	202541	Bolt, Hex, 5/16-18 x 3-3/4
13	6	203218	Washer, 5/16, 3/8 ID - 7/8 OD
14	1	203220	Locknut, 5/16-18 Nylon Insert
15	3	203156	Bolt, Hex Flange, 5/16-18 x 1
16	13	203100	Nut, Hex Flange, 5/16-18
17	3	203617	Cap, Plug 1-3/4 Diameter
18	2	900846	Board Bracket
19	1	203124	Ground Stake
20	1	202438	Nylon Rope
21	1	201252	Label, Adjustment & Moving
22	2	203103	Bolt, Carriage, 5/16-18 x 2
23	12*		Net Clip
24	1	203493	Nut, Hex 1/4-20, Center Lock
25	3	201124	Locknut, Hex, 3/8-16
26	1		Rim
27	1	204850	Pin, Locking
28	4*	203160	Weld Stud, Right Angle, 5/16-18 x 1-1/2
29	1	202814	Pole Cap, Top
30	1	204853	Lanyard, Black Plastic Coil
31	1	203038	Bolt, Carriage, 5/16-18 x 2-3/4
32	2	201129	Spacer, 1.8 Long
33	1	240017	Bolt, Hex, 1/4-20 x 2-1/4
34	3	206360	Bolt, Hex 3/8-16 x 2.625 Long
35	2	904820	Elevator Tube, Lower - Long
36	6	250010	Bolt, Hex, 1/2-13 x 7.50 Long
37	6	201646	Locknut, Hex, 1/2-13
38	8	206311	Spacer, 1/2 Long
39	2	904808	Elevator Tube, Upper - Short
40	1	204855	Handle, Left
41	1	204856	Handle, Right
42	1	204803	Screw, 1-1/2 Long
43	1	904833	Adjustment Rod
44	1	204872	Label, Height Indicator
45	1	204832	Pole Bracket
46	2	203231	Bolt, Carriage, 5/16-18 x 3-1/2
47	2	204857	Spacer, 1.44 Long
48	2	204858	Spacer, Biscuit
49	4	203232	Washer, 3/4 OD
50	2	204859	Pole Bracket Cover
51	2	204837	Spring
52	1		Net
53	1	206990	Bracket Reinforcement
54	1	204860	Wide Body
55	1	905212	Steel Backboard Frame
56	4	202862	Spacer, 1.190 Long x .563 I.D.

* You may have extra parts with this model.

WARRANTY CARD:
Please remember to complete your product registration form either on-line at: www.huffysports.com/warrantycard or mail-in the enclosed postcard.

1.

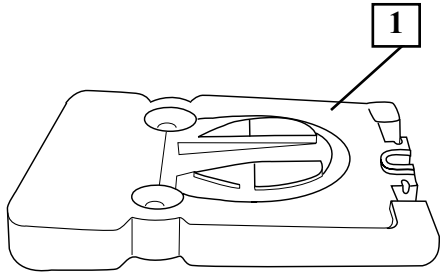

2.

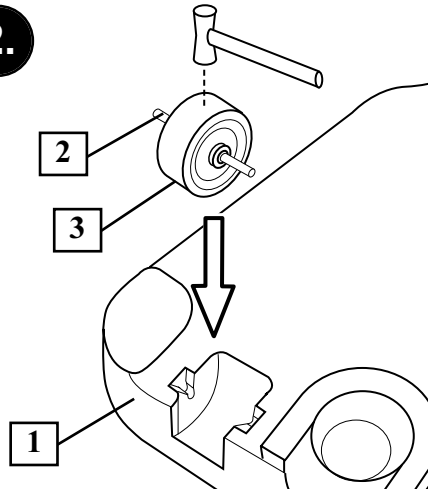

3.

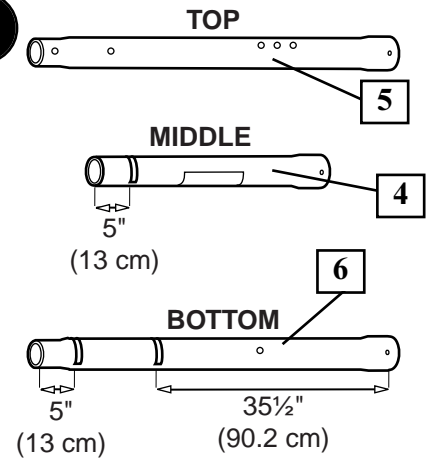

4.

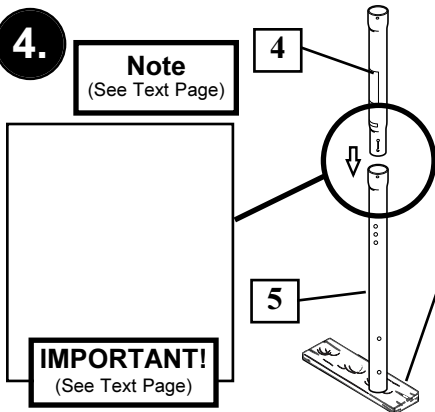

5.

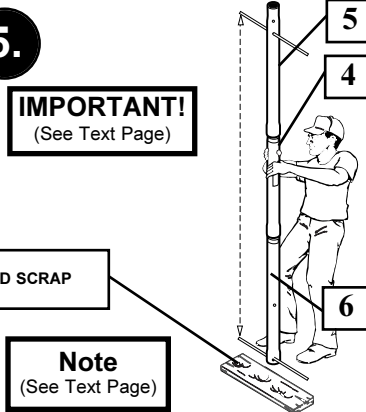

6.

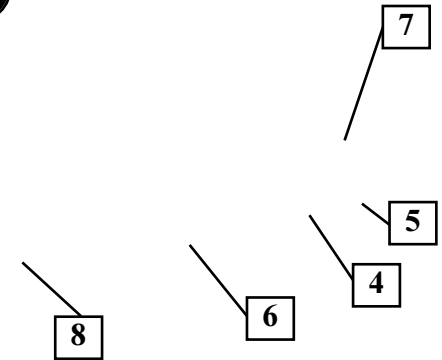

7.

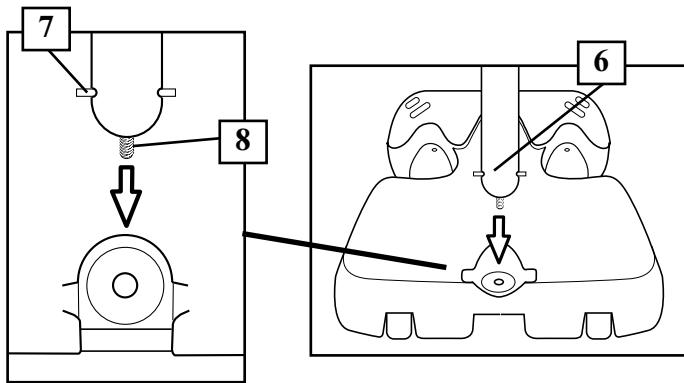

8.

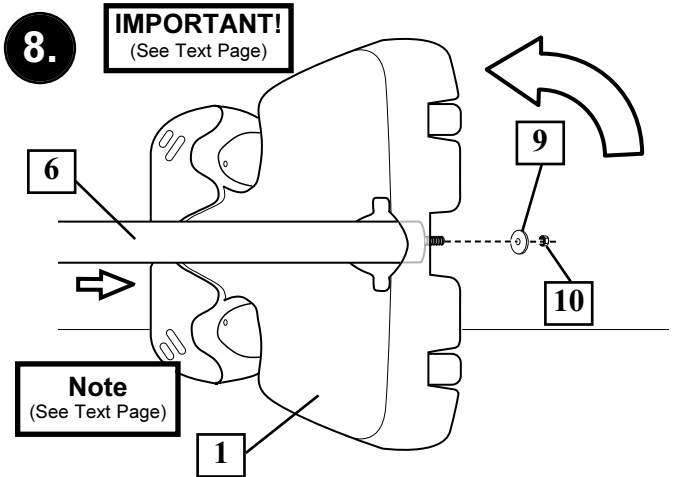

9.

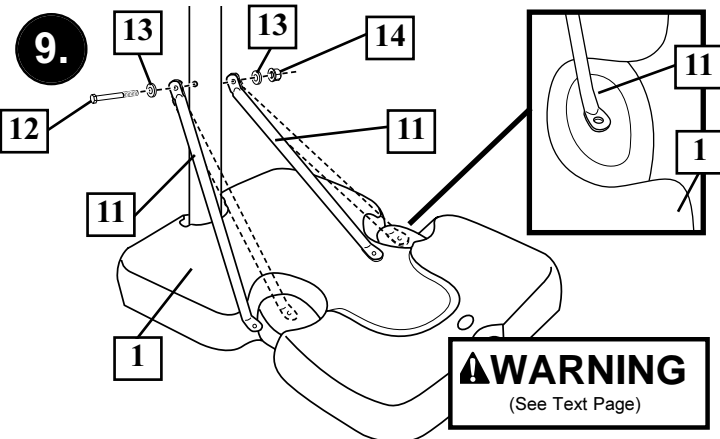

10.

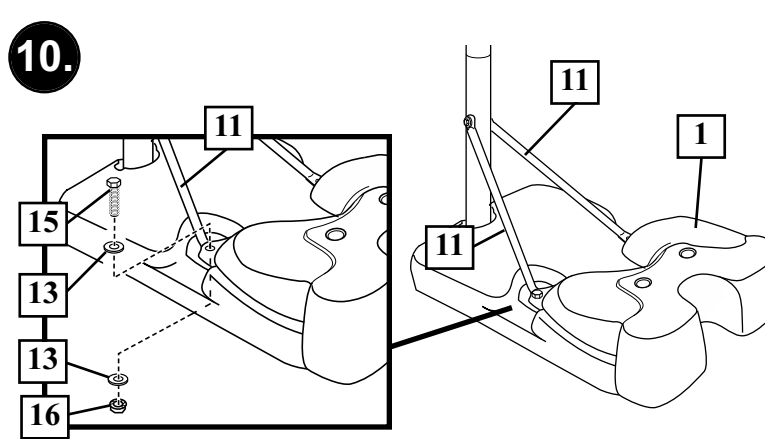

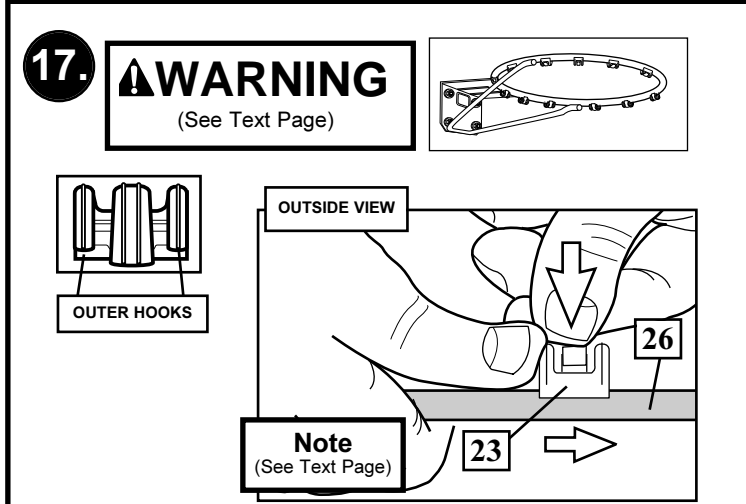
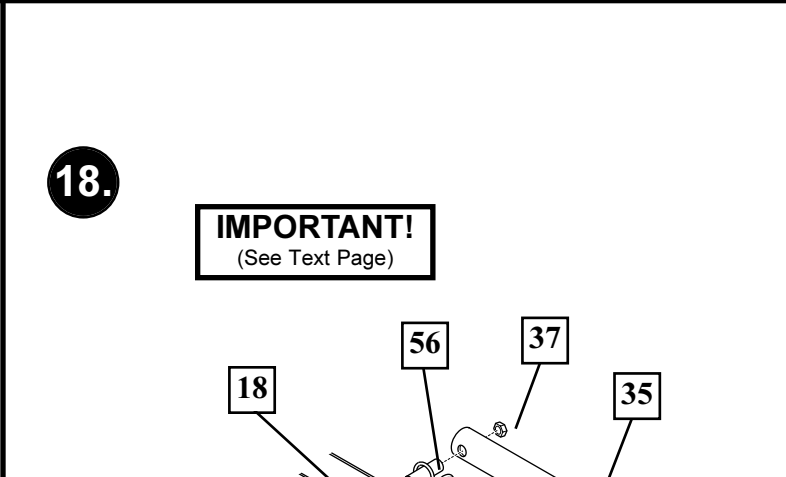
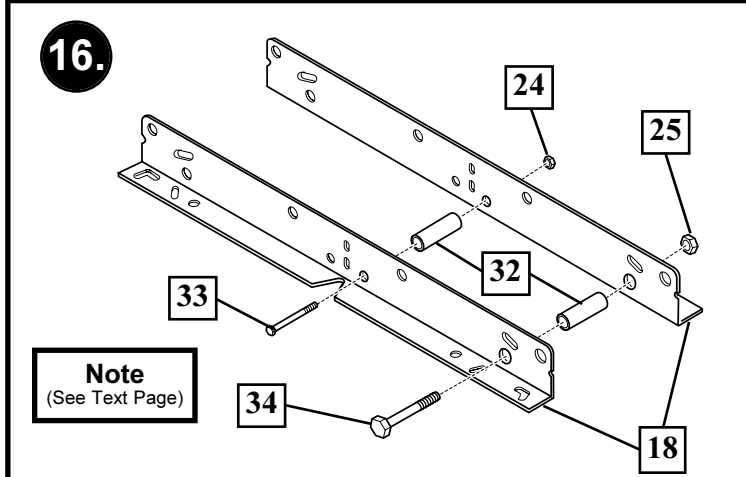
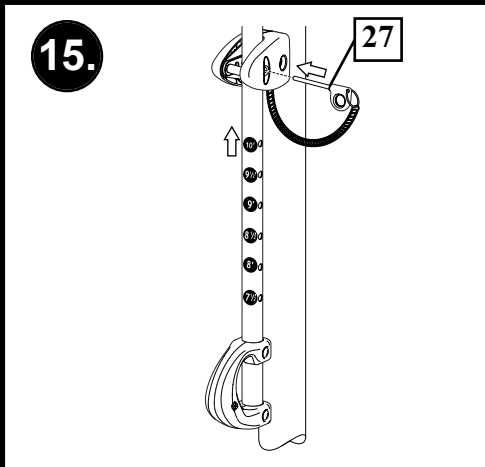
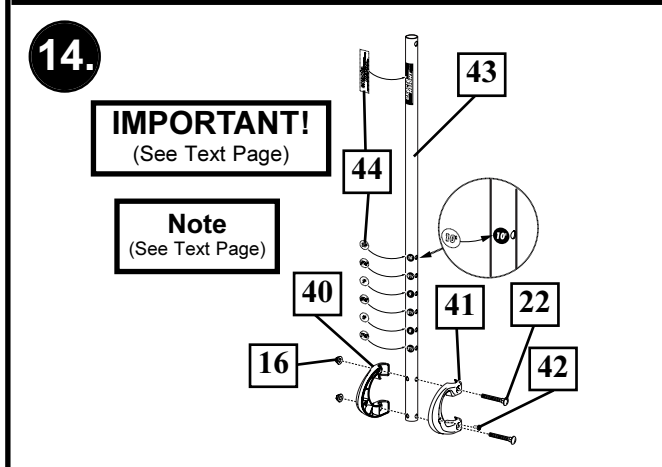
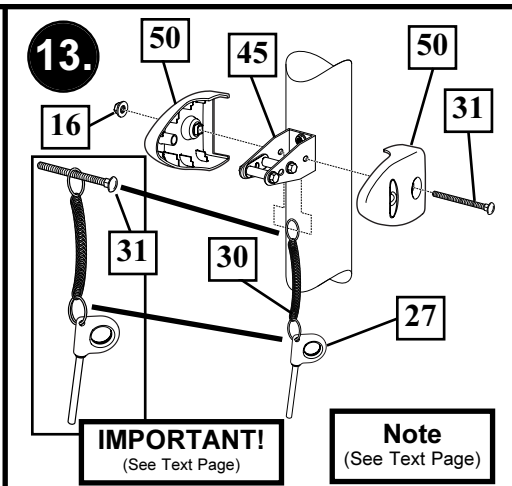
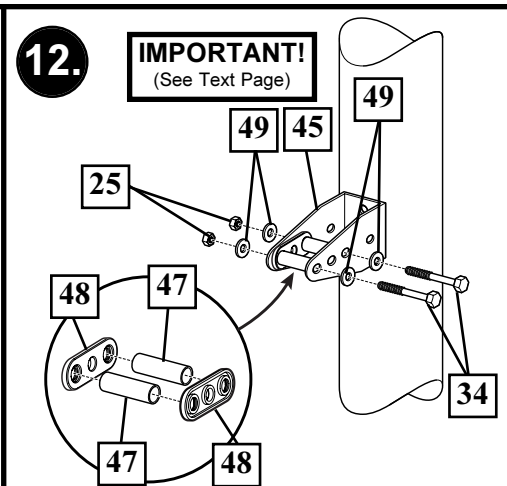
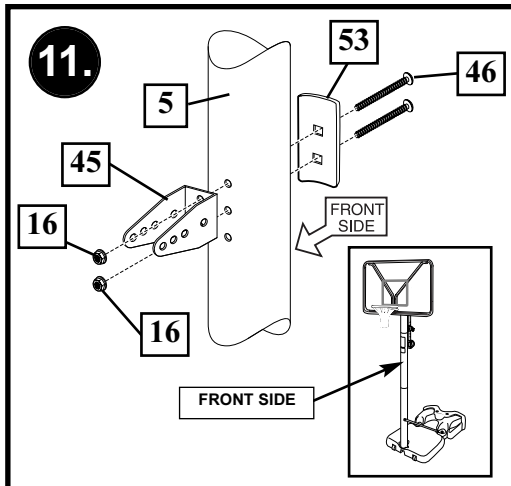

19.

20.

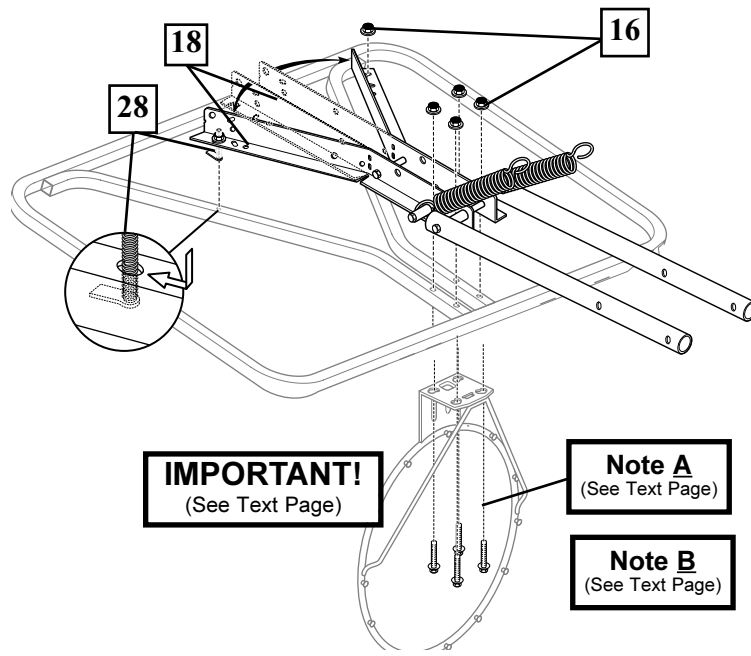

IMPORTANT!
(See Text Page)

Note A
(See Text Page)

Note B
(See Text Page)

21.

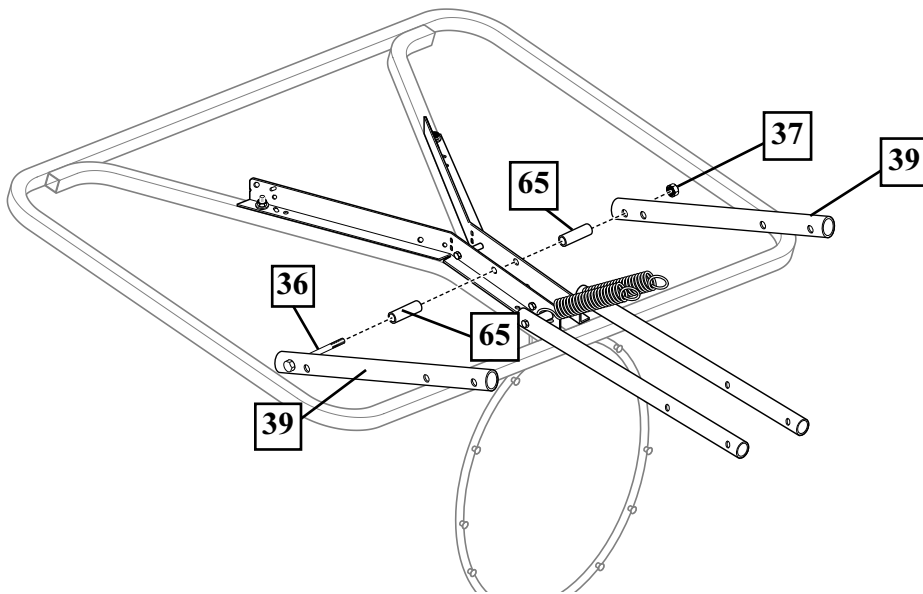

22.

Note
(See Text Page)

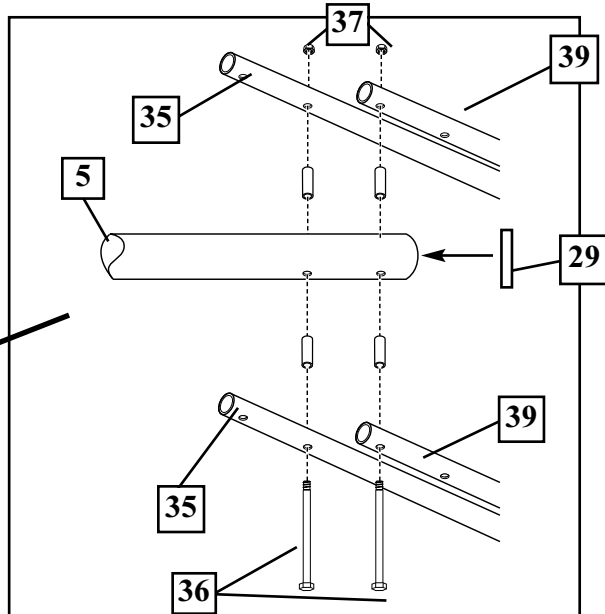
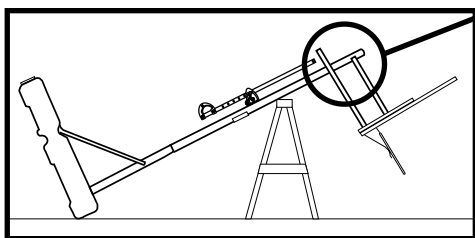

23.

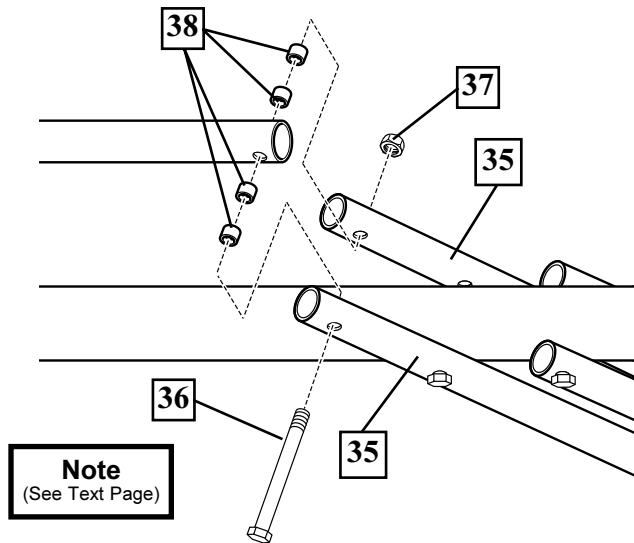

24.

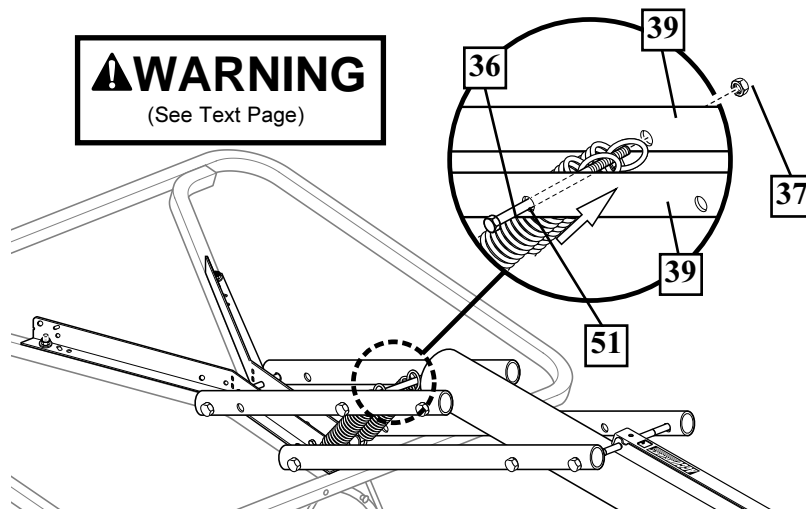

25.

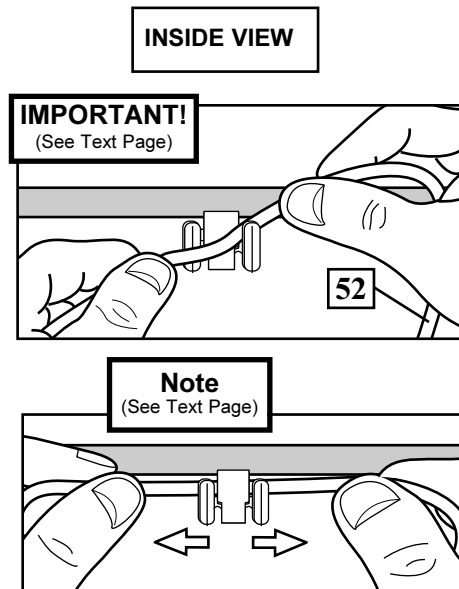

26.

⚠ WARNING
(See Text Page)

IMPORTANT!
(See Text Page)

Note
(See Text Page)

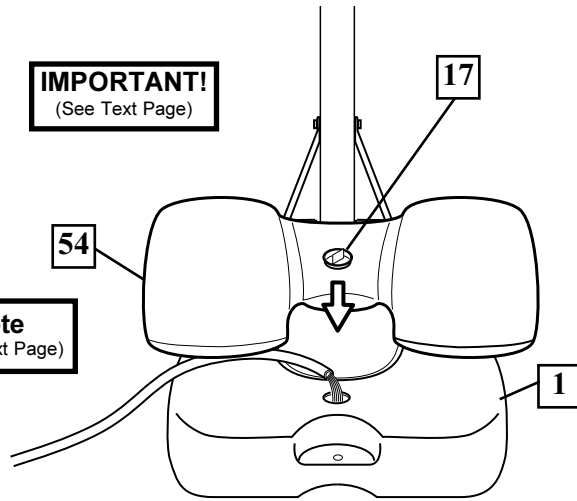

27.

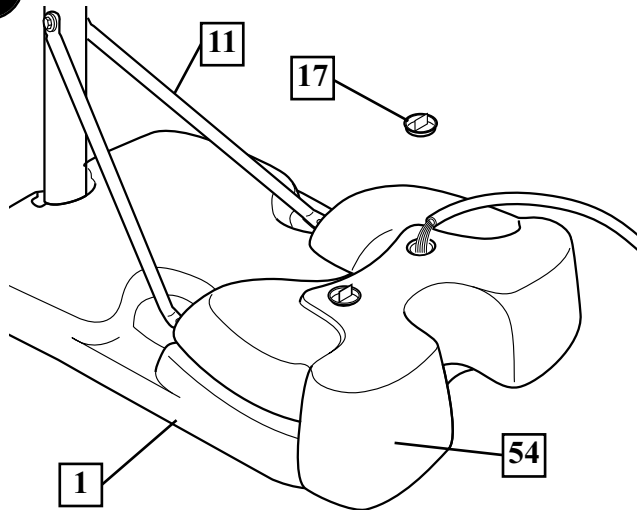

IMPORTANT!
(See Text Page)

28.

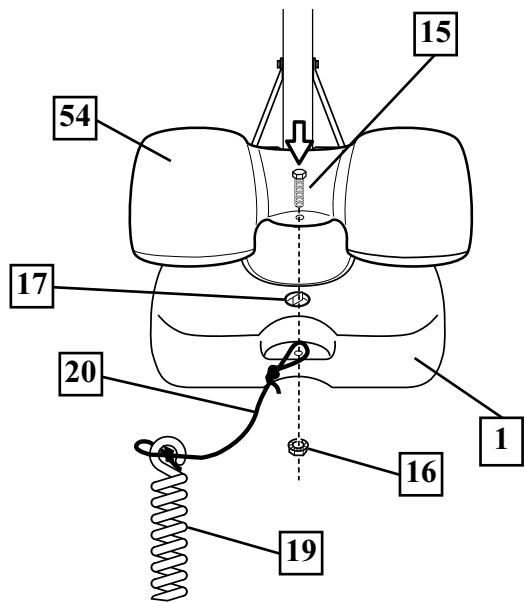

29.

30.

31.

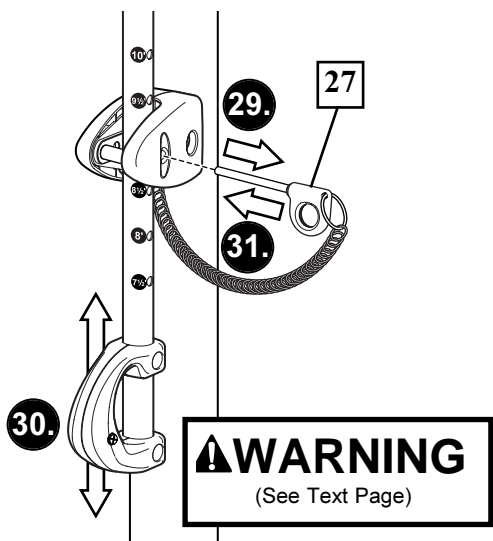

⚠ WARNING
(See Text Page)

32.

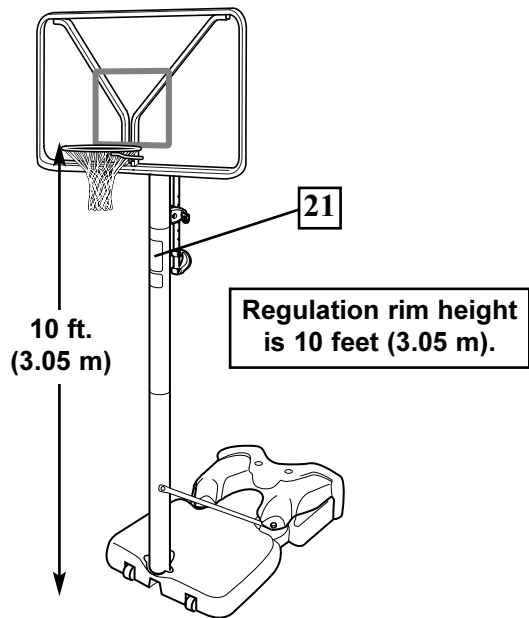

Regulation rim height
is 10 feet (3.05 m).