

WRITE IN YOUR MODEL NUMBER:

Customer Service Center • N53 W24700 South Corporate Circle • Sussex, WI 53089 • U.S.A.

IMPORTANT! In U.S. and Canada only:
Have questions? ...don't go back to the store!

We appreciate your purchasing one of our many fine products. We are sure that you will be very satisfied with your selection. Although great care and effort have been taken, occasionally problems may occur. To ensure prompt and correct handling of any problems, or to answer any questions, please contact our Toll-Free Customer Service Number listed below. Service will be quicker if you have your Model Number (found on carton) and assembly instructions ready when calling. PLEASE WRITE YOUR MODEL NUMBER IN THE SPACE PROVIDED ABOVE.

SAFETY INSTRUCTIONS

FAILURE TO FOLLOW THESE SAFETY INSTRUCTIONS MAY RESULT IN SERIOUS INJURY, PROPERTY DAMAGE AND VOID WARRANTY.

Owner must ensure that all players know and follow these rules for safe operation of the system.

To ensure safety, do not attempt to assemble this system without following the instructions carefully. Proper and complete assembly, use and supervision is essential for proper operation and to reduce the risk of accident or injury. A high probability of serious injury exists if this system is not installed, maintained, and operated properly. Check entire box and inside all packing material for parts and/or additional instructional material. Before beginning assembly, read the instructions and identify parts using the hardware identifier and parts list in this document.

- If using a ladder during assembly, use extreme caution.
- Two (2) people are recommended for this operation.
- Check base regularly for leakage. Slow leaks could cause system to tip over unexpectedly.
- Seat the pole sections properly (if applicable). Failure to do so could allow the pole sections to separate during play and/or transport of the system.
- Climate, corrosion or misuse could result in system failure.
- Minimum operational height is 6' 6" (1.98 m) to the bottom of backboard.
- This equipment is intended for home recreational use only and NOT excessive competitive play.
- Read and understand the warning label affixed to pole. Label is shown on page 1.
- The life of your basketball pole depends on many conditions. The climate, placement of the pole, the location of the pole, exposure to corrosives such as pesticides, herbicides or salts are all important.
- If technical assistance is required, contact Huffy Sports.
- Adult supervision is recommended when adjusting height.

Most injuries are caused by misuse and/or not following instructions. Use caution when using this system.

For more information on assembly, placement, proper use and maintenance, visit The American Basketball Council website at <http://www.smarthoops.com>.

The NBA and individual NBA member team identifications reproduced on this product are trademarks and copyrighted designs, and/or other forms of intellectual property, that are the exclusive property of NBA Properties, Inc. and the respective NBA member teams and may not be used, in whole or in part, without the written consent of NBA Properties, Inc.

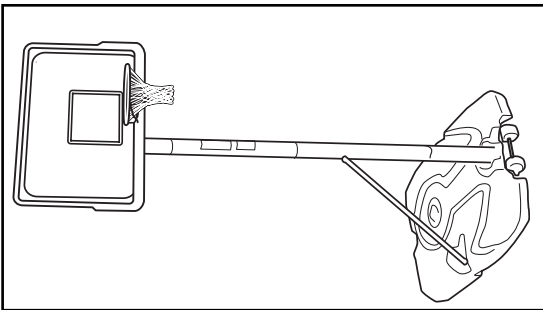

REQUIRED TOOLS AND MATERIALS:

- Two People
- Tape Measure
- Wood Board (Two of Scrap)
- Wrenches: (Two of Each) 7/16", 1/2", 9/16", 3/4" or Large and Small Adjustable Wrenches
- Sawhorse or Support Table
- Garden Hose or Sand (300 lb. (136 kg))
- Hammer
- Phillips Screwdriver
- 1/2" & 9/16" Extended Deep Socket w/ Extension Recommended

NOTICE TO ASSEMBLERS
ALL Huffy Sports basketball systems, including those used for displays, MUST be assembled and ballasted with sand or water according to instructions. Failure to follow instructions could result in **SERIOUS INJURY**. It is **NOT** acceptable to devise a makeshift weight system.

25

HEIGHT ADJUSTMENT

TO ADJUST BACKBOARD:

1. TO RAISE BACKBOARD: Slowly push up on the rim with broom handle or wooden dowel, diameter as shown. To engage locking mechanism at desired height.

2. TO LOWER BACKBOARD: Push up on broom handle and carefully lower backboard to lowest position.

MOVING SYSTEM

1. Adjust basketball backboard height to lowest position.
2. With holding pole, rotate basketball until wheels engage with ground.
3. Move basketball system to desired location.
4. Carefully rotate basketball system upright.
5. Reattach ground restraint and check system for stability.

WARNING

FAILURE TO FOLLOW THESE WARNINGS MAY RESULT IN SERIOUS INJURY AND/OR PROPERTY DAMAGE.

Owner must ensure that all players know and follow these rules for safe operation of the system.

- DO NOT HANG on the rim or any part of the system including backboard, support braces or net.
- During play, especially when performing dunk type activities, keep player's face away from the backboard, rim and net. Serious injury could occur if feet/hands come in contact with backboard, rim or net.
- Do not slide, climb, shake or play on base and/or pole.
- After assembly is complete, fill system completely with water or sand and stake to the ground. Never leave system in an upright position without filling base with weight, as system may tip over causing injuries.
- When adjusting height or moving system, keep hands and fingers away from moving parts.
- Do not allow children to move or adjust system.
- During play, do not wear jewelry (rings, watches, necklaces, etc.). Objects may entangle in net.
- Surface beneath the base must be smooth and free of gravel or other sharp objects. Punctures cause leakage and could cause system to tip over.
- Keep organic material away from pole bases. Grass, litter, etc. could cause corrosion and/or deterioration.
- Check pole system for signs of corrosion (rust, pitting, chipping) and repaint with exterior enamel paint. If rust has penetrated through the steel anywhere, replace pole immediately.
- Check system before each use for proper ballast, loose hardware, excessive wear and signs corrosion and repair before use.
- Check system before each use for instability.
- Do not use system during windy and/or severe weather conditions: system may tip over. Place system in the storage position and/or in an area protected from the wind and free from personal property and/or overhead wires.
- Never play on damaged equipment.
- See instruction manual for proper installation and maintenance.
- When moving system, use caution to keep mechanism from shifting.
- Keep pole top covered with cap at all times.
- Do not allow water in tank to freeze. During sub-freezing weather add non-toxic antifreeze, sand or empty tank completely and store. (Do not use salt.)
- Use extreme caution if placing system on sloped surface. System may tip over more easily.

HUFFY SPORTS

In the U.S.: 1-800-558-5234 and Canada: 1-800-284-8339

201241 299

Toll-Free Customer Service Number for U.S.: 1-800-558-5234, For Canada: 1-800-284-8339, For Europe: 00 800 555 85234 (Sweden: 009 555 85234), For Australia: 1-800-333 061 - Internet Address: <http://www.huffysports.com>

BEFORE YOU START!

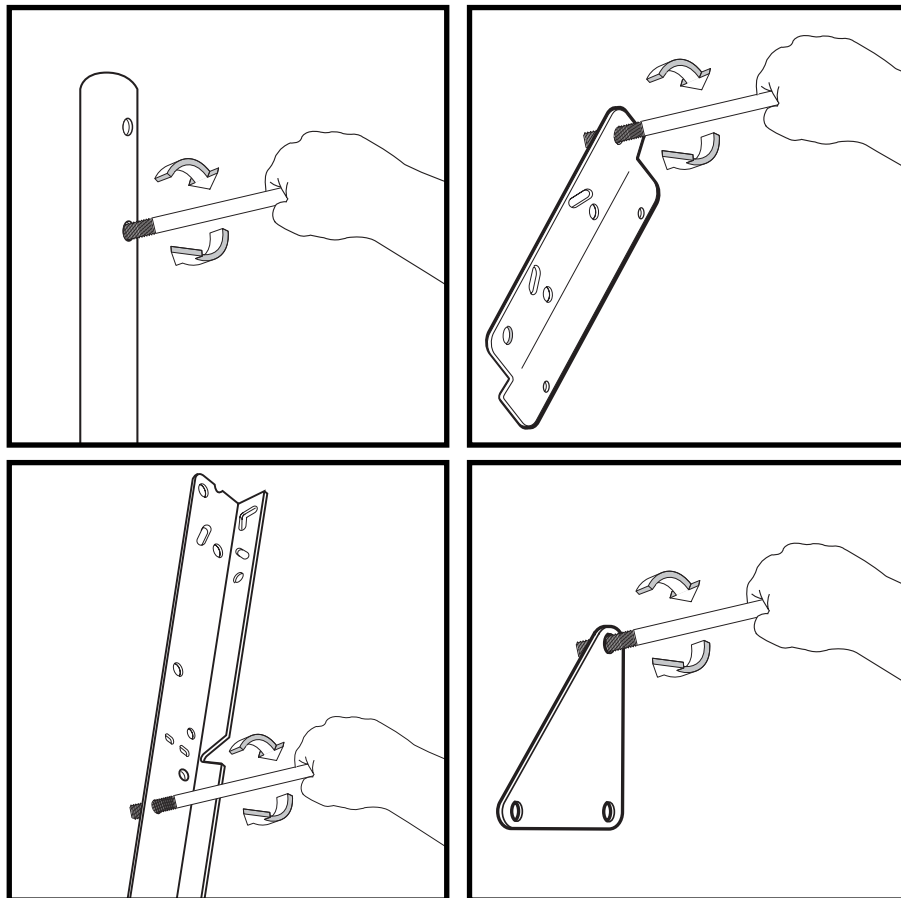

To ensure optimal playability of backboard system, a close tolerance fit between the elevator components and hardware is required. Test fit large bolts into large holes of elevator tubes, backboard brackets and triangle plates. Carefully rock them in a circular motion to ream out any excess paint from holes if necessary.

AVANT DE COMMENCER !

Pour garantir l'utilisation optimale du panneau, les composants du système élévateur et la visserie doivent être bien ajustés (serrés). À titre d'essai, insérez les gros boulons dans les gros trous des tubes du système élévateur, des supports du panneau et des plaques triangulaires. Basculez-les avec précaution en imprimant un mouvement circulaire pour éliminer l'excédent de peinture, si nécessaire.

¡ANTES DE COMENZAR!

Para asegurar el óptimo rendimiento del sistema del respaldo en el juego, se requiere un ajuste de tolerancia estrecha entre los componentes del elevador y el herraje. Pruebe el ajuste de los pernos grandes en los orificios grandes de los tubos elevadores, soportes del respaldo y placas triangulares. Cuidadosamente muévalos en círculos para eliminar cualquier exceso de pintura, si es necesario.

VORBEREITENDE MASSNAHMEN

Um sicherzustellen, dass das Korbwandsystem optimal für den Spielbetrieb geeignet ist, müssen die Komponenten der Verlängerungsvorrichtung und die verschiedenen Befestigungsteile fest miteinander verschraubt werden. Große Schrauben zur Probe in die großen Löcher der Verlängerungsröhre, Korbwandklammern und Dreiecksplatte stecken und diese vorsichtig in einer Kreisbewegung hin- und herbewegen, um eventuelle Farbrückstände aus den Bohrungen zu entfernen.

HARDWARE IDENTIFIER (BOLTS & PINS)

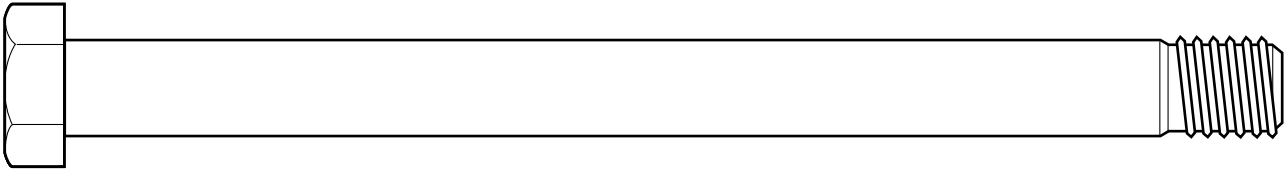

Item #43 (5)

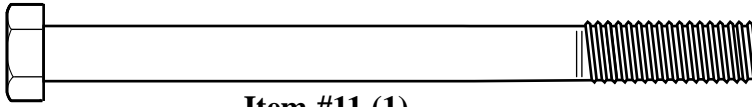

Item #11 (1)

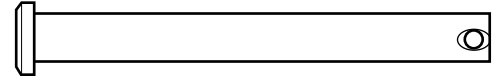

Item #34 (1)

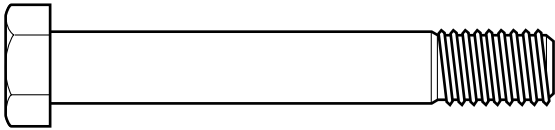

Item #35 (3)

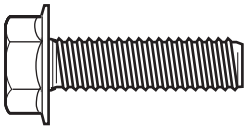

Item #15 (6)

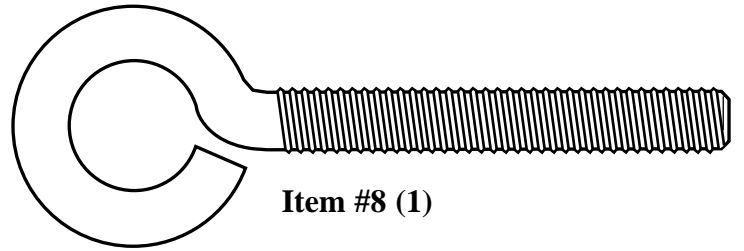

Item #8 (1)

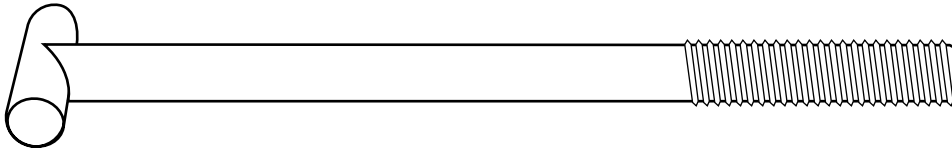

Item #36 (1)

HARDWARE IDENTIFIER (NUTS & WASHERS)

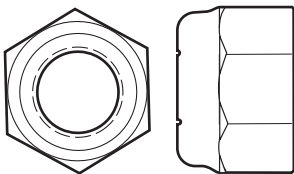

Item #39 (5)

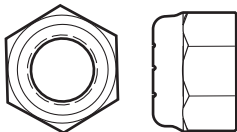

Item #9 (4)

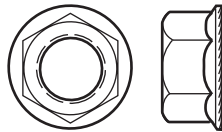

Item #16 (6)

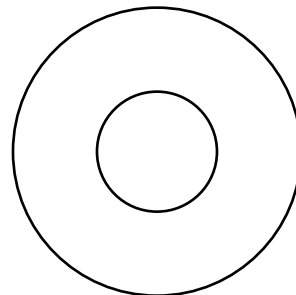

Item #38 (1)

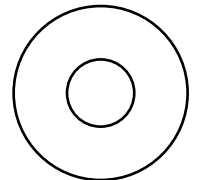

Item #12 (6)

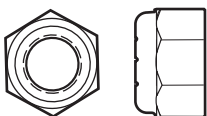

Item #13 (1)

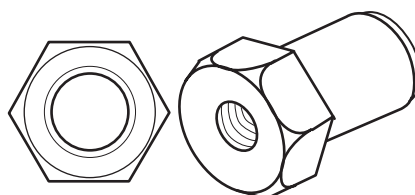

Item #40 (1)

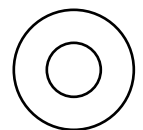

Item #18 (2)

* You may have extra parts with this model.

HARDWARE IDENTIFIER (STEEL SPACERS & RODS)

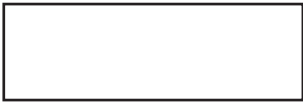

Item #33 (2)

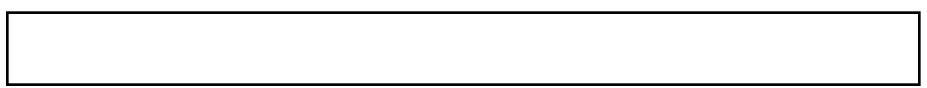

Item #7 (1)

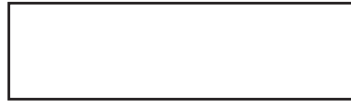

Item #45 (1)

HARDWARE IDENTIFIER (PLASTIC SPACERS & CLIPS)

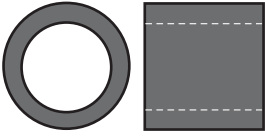

Item #42 (4)

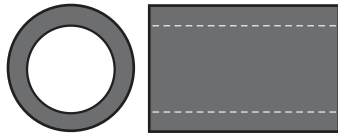

Item #37 (1)

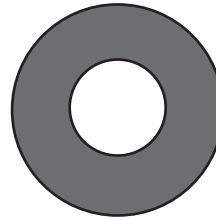

Item #17 (4)



Item #20 (12)

HARDWARE IDENTIFIER (OTHER)

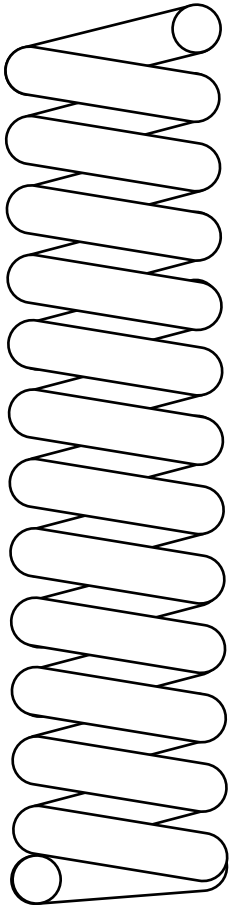

Item #30 (1)

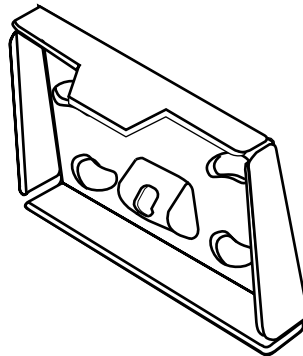

Item #32 (1)

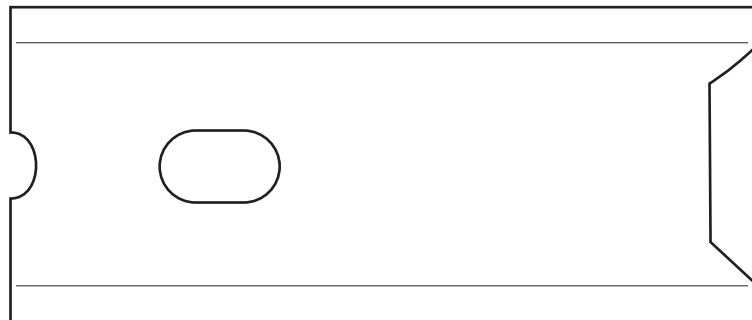

Item #31 (1)



Questions or Missing Parts?

STOP!

DON'T go back to store!

Call TOLL-FREE Customer Service
Number listed on the front page!

1. Remove contents from tank (1).
 2. Correctly identify each pole section and mark indicated distance from ends with tape as shown.
 3. **IMPORTANT! Center alignment slot of middle pole section (5) in a lower hole of top pole section (4) as shown.** While maintaining alignment, bounce pole top (4) and middle section (5) together as shown until they no longer move toward taped reference mark. Upright assembly. **NOTE:** Pole sections should have a 3-1/2" (9 cm) minimum overlap.
 4. **IMPORTANT! Center alignment slot of lower pole section (6) in a lower hole of middle pole section (5) as in step 3.** While maintaining alignment, bounce assembly and lower pole section (6) together as shown until they no longer moved toward taped reference mark. **NOTE:** Pole sections should have a 3-1/2" (9 cm) minimum overlap.
 5. Install rod (7) through holes in bottom pole section (6) and eyebolt (8).
 6. Install wheel axle (2) through wheel carriage (19) and install wheels (3) onto wheel axle (2) with spacers (17) as shown. Insert pole assembly into tank assembly as shown. Secure bottom pole (6) section to tank and wheel carriage as shown. A deep socket is recommended. **NOTE:** Two people recommended for this step. **IMPORTANT! DO NOT OVER TIGHTEN.**
 7. Secure base struts (10) to pole using bolt (11), washers (12), and nut (13), as shown. Rotate the non-secured ends of base struts (10) as shown. **NOTE:** Strut orientation
- ▲ WARNING: TIGHTEN BOLT (11) IN LOCKNUT (13) UNTIL FLUSH (EVEN) WITH LOCKNUT'S OUTER EDGE.**
8. Secure base struts (10) to base using bolt (15), washers (12), and nut (16).
 9. Assemble backboard brackets (29) using spacers (33) bolts (35) and nuts (9) as shown.
 10. Fit spacer (45) into pawl (27). Then continue to assemble as shown.
 11. **IMPORTANT! Test fit bolts into holes of backboard brackets (29) and carefully rock them in a circular motion to ream out paint from holes if necessary.** Attach lower elevator tubes (44) to backboard brackets (29) using spacers (17, 42 & 37), bolts (43) ratchet (28), and nuts (39) as shown.
 12. Secure pawl (27) in place with clevis pin (34) and washers (18).
 13. **▲ WARNING: USE EYE PROTECTION WHEN INSTALLING SPRINGS.** Stretch spring (41) into position with pliers.
 14. **▲ WARNING: TWO PERSON MINIMUM REQUIRED FOR THIS PROCEDURE. NOT FOLLOWING RECOMMENDATION MAY RESULT IN BODILY INJURY.**
Insert "T" bolt (36) through Slam Jam bracket (32) as shown. Secure Slam Jam bracket (32) and backboard bracket (29) assemblies to backboard. Using bolt (15) and nut (16) as shown.
 15. Attach upper elevator tubes (44) to backboard brackets (29) using spacers (42) bolt (43) and nut (39) as shown.

16. **▲ WARNING: TWO PERSON MINIMUM REQUIRED FOR THIS PROCEDURE. NOT FOLLOWING RECOMMENDATION MAY RESULT IN BODILY INJURY.**

Support pole on sawhorse. Attach upper and lower elevator tubes (44) to upper pole section (4) using bolts (43) and nuts (39) as shown. Attach pole cap (22) as shown.

17. Fit rim (21) securely into bracket (32) as shown. Install reinforcement bracket (31) onto "T" bolt (36) as shown. Install spring (30) onto "T" bolt (36) as shown. Install special nut (40) and washer (38) onto "T" bolt (36). Tighten nut (40) until flush with end of "T" bolt (36).

▲ WARNING: USE OF THIS PRODUCT WITHOUT PROPER INSTALLATION OF SMART CLIPS, OR WHEN ALL SMART CLIPS ARE NOT PRESENT COULD RESULT IN BODILY HARM. BE SURE TO FOLLOW DIRECTIONS CAREFULLY.

18. Install net clips as shown. (See illustration)

19. Install net as shown. (See illustration)

20. **▲ WARNING: DO NOT LEAVE ASSEMBLY UNATTENDED WHEN EMPTY, MAY TIP OVER.**

▲ WARNING: TWO PERSON MINIMUM REQUIRED FOR THIS PROCEDURE. NOT FOLLOWING RECOMMENDATION MAY RESULT IN BODILY INJURY.

Roll the completed assembly to the desired playing area. Insert the T-strap (14) through the slot on the back of the base as shown. Secure the unit to ground by twisting the tie down stake (23) into the ground and hooking the T-strap (14) onto the tie down stake (23). Fill tank with 33 gallons of water. Secure base caps (24) into base as shown. **IMPORTANT! Add two gallons (7.6 Liters) of non-toxic antifreeze in sub-freezing climates.**

21. Apply the height adjustment and moving label (25) to the front of the pole as shown.

▲ WARNING: DO NOT ALLOW CHILDREN TO ADJUST HEIGHT.

WARRANTY CARD:

Please remember to complete your product registration form either on-line at: www.huffysports.com/warrantycard or mail-in the enclosed postcard.

PARTS LIST - See Hardware Identifier

<u>Item</u>	<u>Qty.</u>	<u>Part No.</u>	<u>Description</u>	<u>Item</u>	<u>Qty.</u>	<u>Part No.</u>	<u>Description</u>
1	1	206657	Tank, (Black)	30	1	203472	Spring, Black, Slam Jam
2	1	200628	Wheel Axle	31	1	200318	Bracket, Reinforcement, Slam Jam
3	2	226401	Wheel, 4" (Black)	32	1	900033	Bracket Slam Jam
4	1	90021701	Top Pole Section	33	2	200874	Spacer .402 I.D. x.500 O.D. x 1.5 Long
5	1	904840	Middle Pole Section	34	1	206305	Clevis Pin 1/4 x 2-9/32 Large
6	1	900136	Bottom Pole Section	35	3	206360	Bolt, Hex 3/8-16 x 2.65 Long
7	1	202820	Rod, 3/8 O.D. x 4-3/4 Long	36	1	203796	T-Bolt, 3/8-16 x 5" Large
8	1	202822	Eyebolt, 3/8-16 x 2-1/2 Long	37	1	202587	Spacer .Plastic, 1" Long
9	4	203063	Nylon Insert Lock Nut, 3/8-16	38	1	203470	Washer Flat, Slam Jam
10	2	906206	Tank Strut	39	5	206340	Nut 1/2-13
11	1	201625	Bolt, Yellow Dichromate, 5/16-18 X 3.60" Long	40	1	203795	Nut, Special, Slam Jam
12	6	203218	Washer, Flat, 3/8 I.D.	41	1	201125	Return Ratchet Spring
13	1	203099	Nylon Insert Lock Nut, 5/16-18	42	4	201642	Spacer .530 I.D. x.5 O.D. x .63 Long
14	1	201568	Anchor, T-Strap	43	5	206304	Bolt 1/2-13 x 6-5/16 Long
15	6	205528	Bolt, Hex Flange, 5/16-18 x 1 Long	44	4	900184	Elevator Tubes
16	6	203100	Nut, Hex Flange, 5/16-18	45	1	201129	Spacer .402 I.D. x .500 O.D. x 1.75 Large
17	4	201651	Spacer .500 I.D. x .25 Long				
18	2	206303	Washer 1/4 Flat				
19	1	200627	Wheel Bracket				
20	12	201219	Clip, Net Holder				
21	1		Rim				
22	1	206219	Cap, Pole Top 3"				
23	1	203124	Stake, Tie Down				
24	2	203617	Plug Cap				
25	1	201257	Label, Height Adjustment and Moving				
26	1		Net				
27	1	201160	Pawl Lever				
28	1	201159	Ratchet				
29	2	900964	Backboard Bracket				

NOTE: Hardware kit is designed for more than one style of basketball system.
Not all hardware will be used.



Questions or Missing Parts?

DON'T go back to store!

Call TOLL-FREE Customer Service Number listed on the front page!

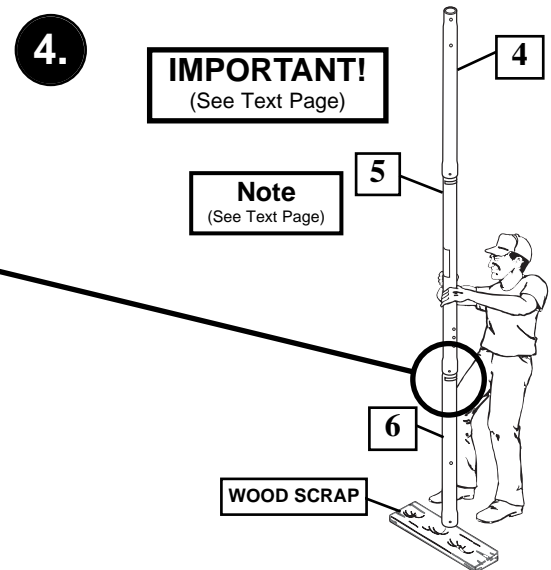
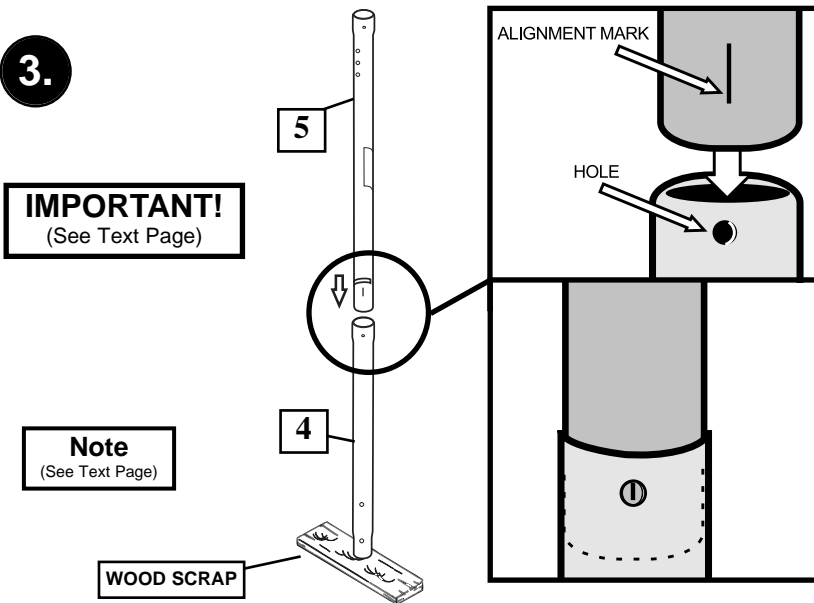
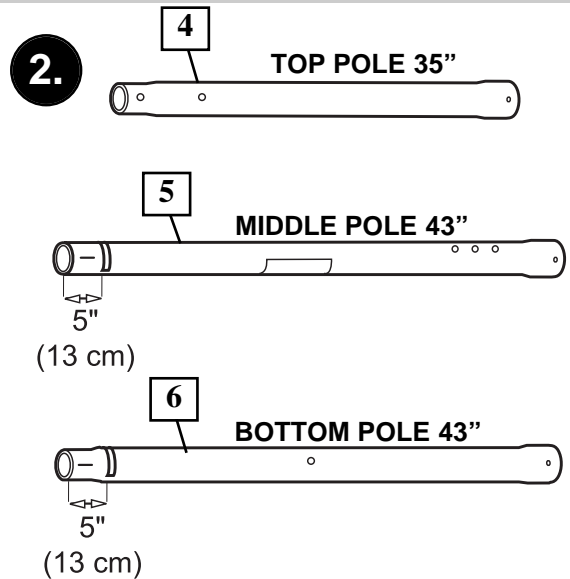
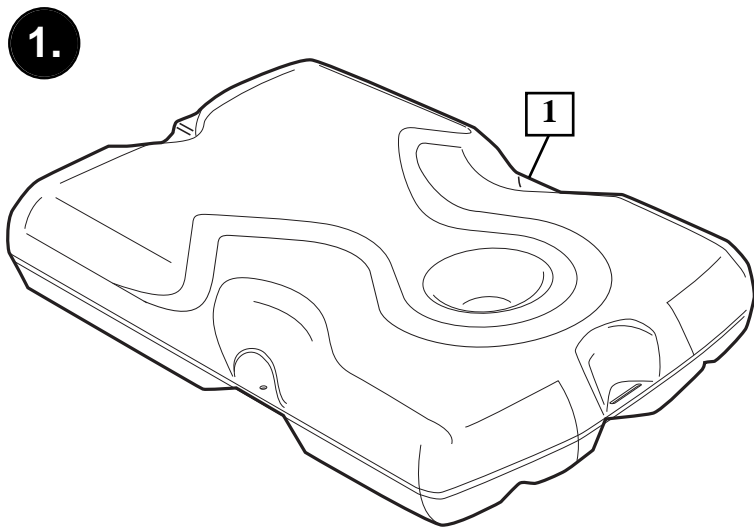

5.

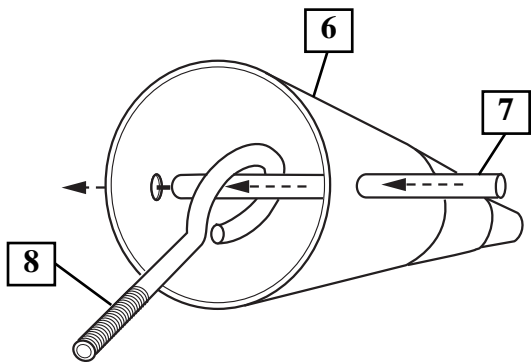

6.

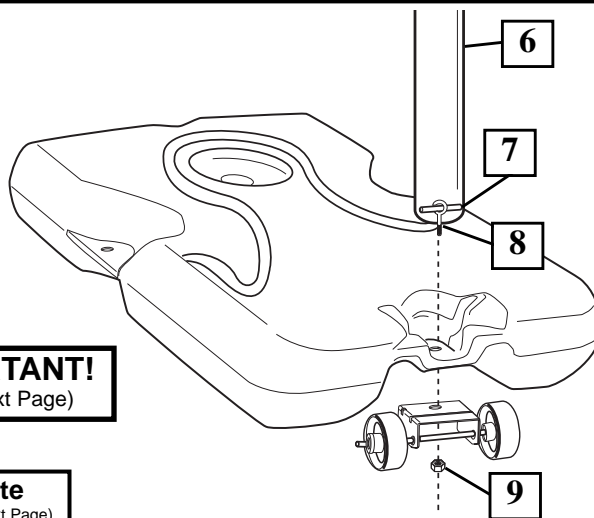

IMPORTANT!

(See Text Page)

Note

(See Text Page)

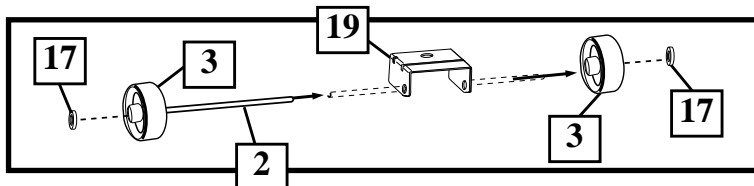

7.

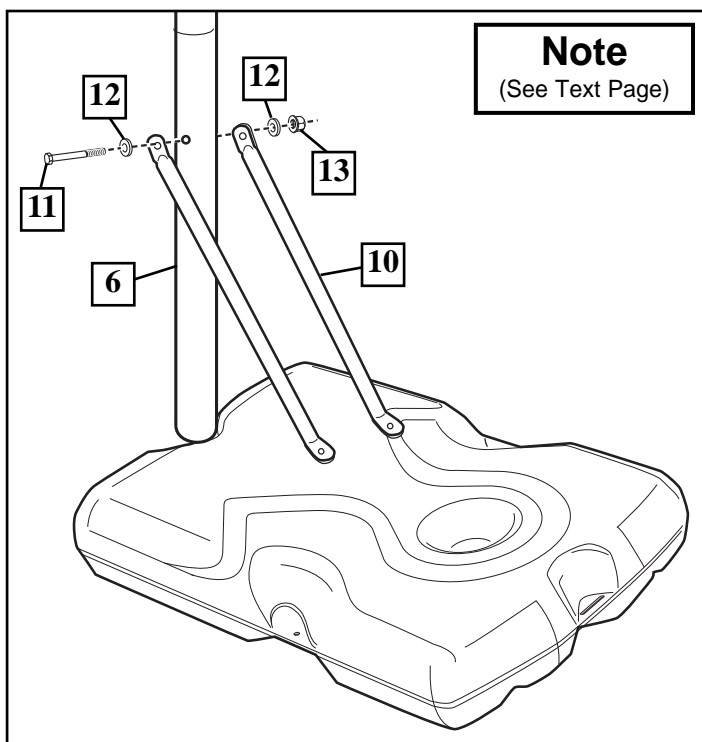

Note

(See Text Page)

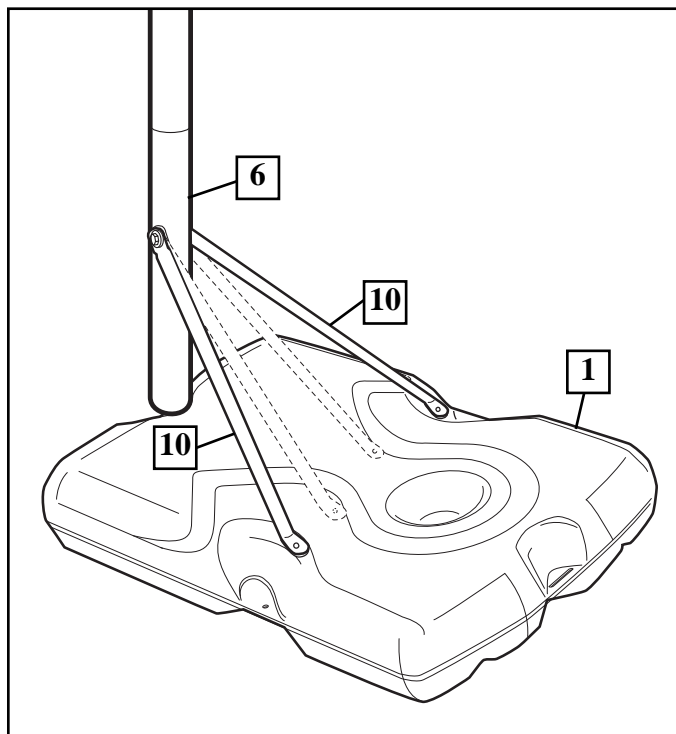

8.

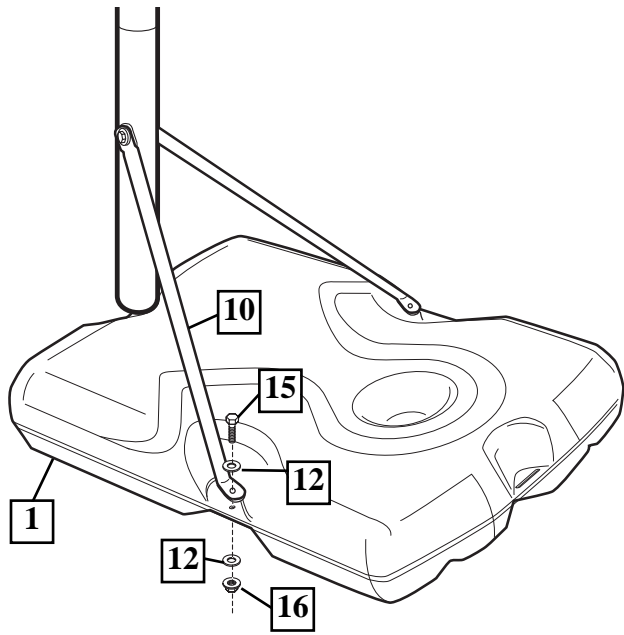

9.

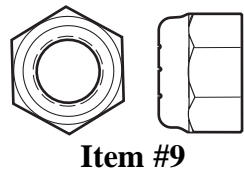

Item #9

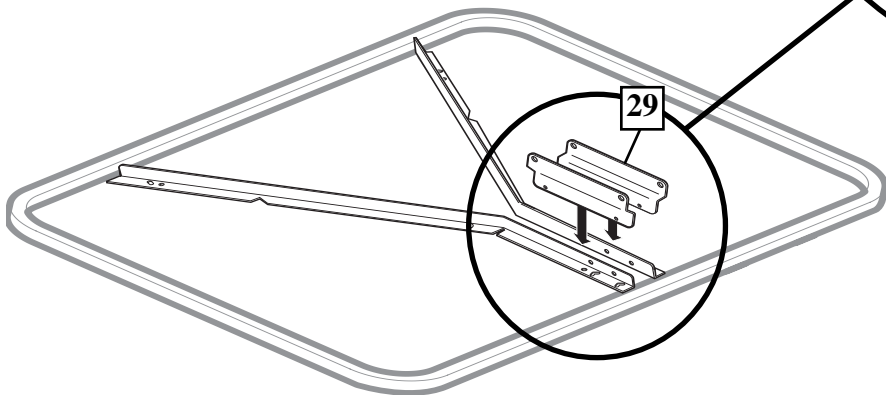
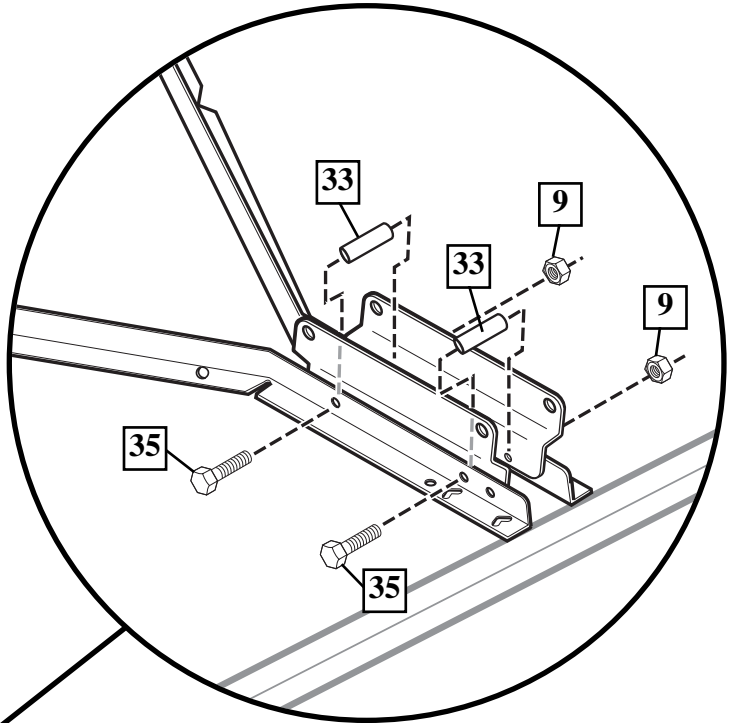

10.

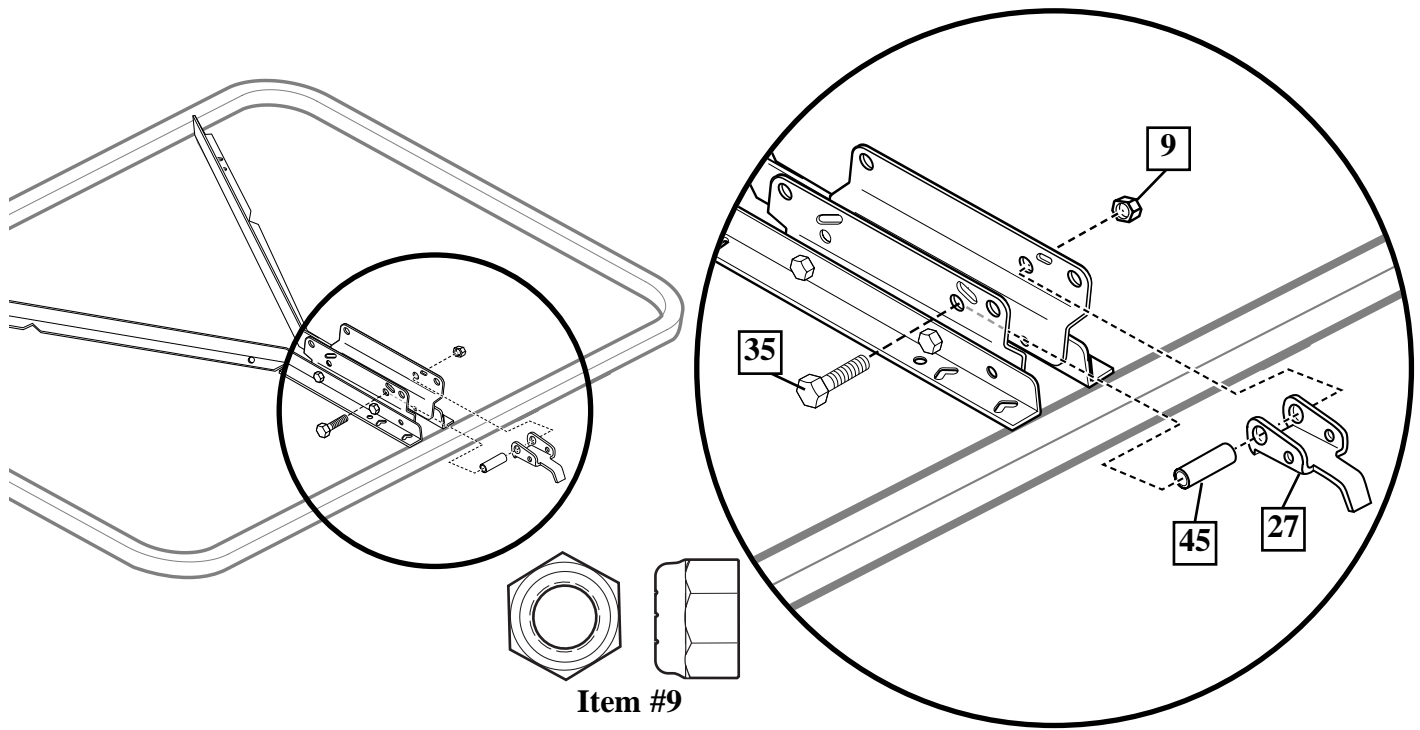

Item #9

11.

TOWARD BOARD

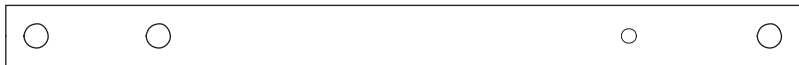

TOWARD POLE

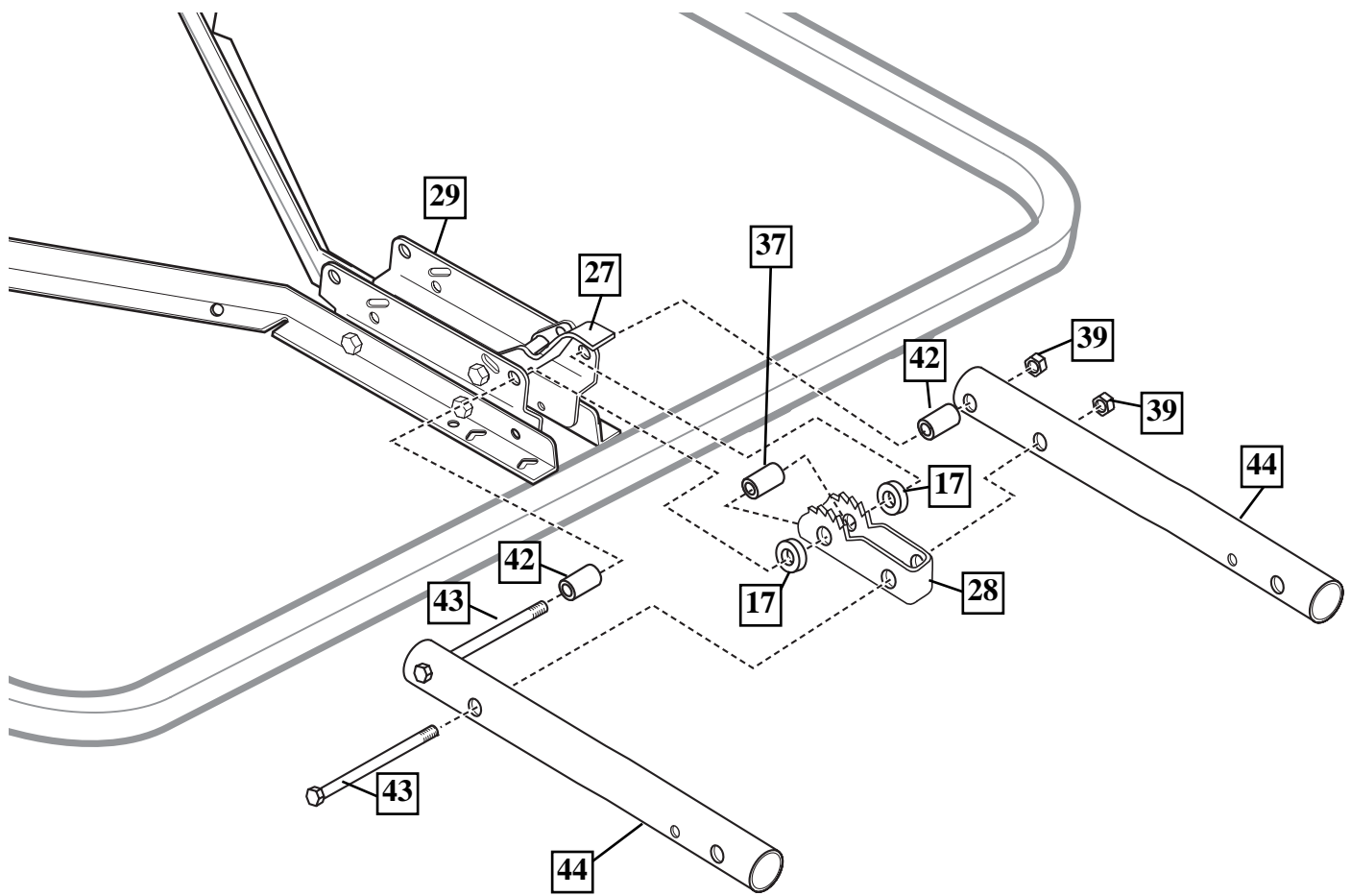

12.

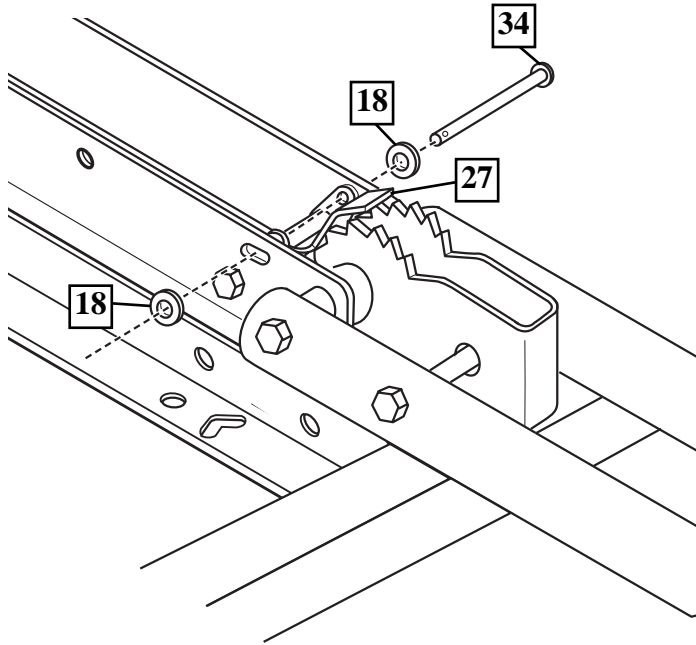

13.

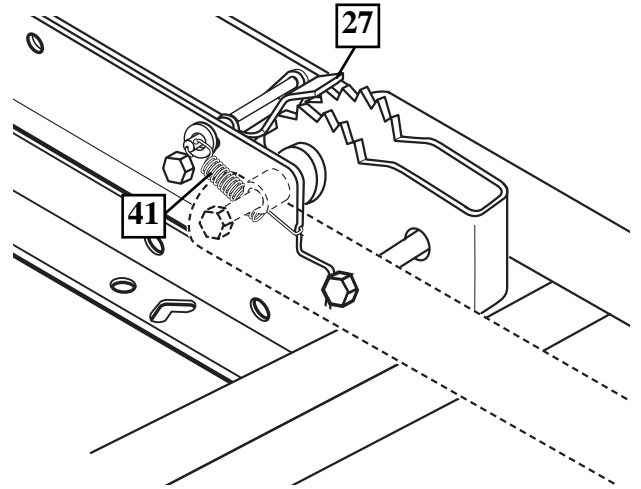

14.

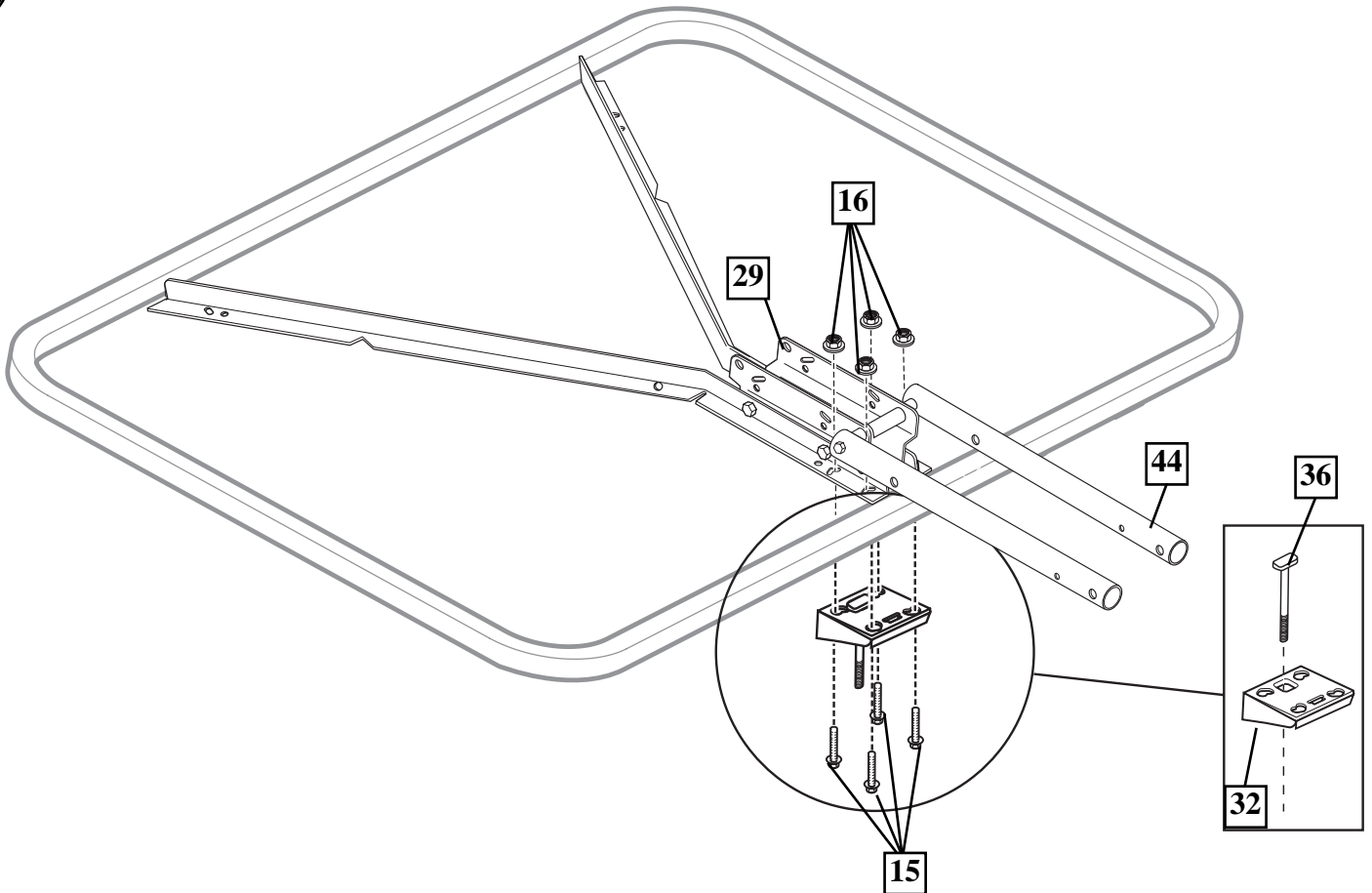

15.

TOWARD BOARD



TOWARD POLE

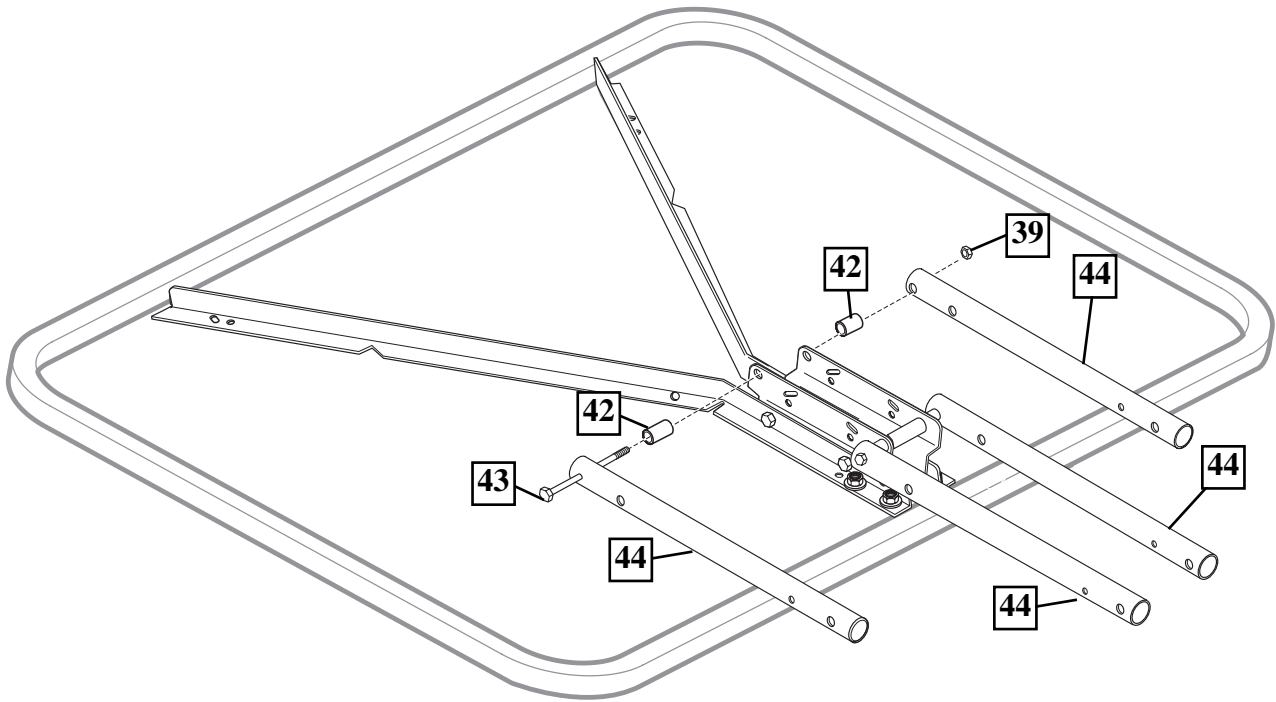

16.

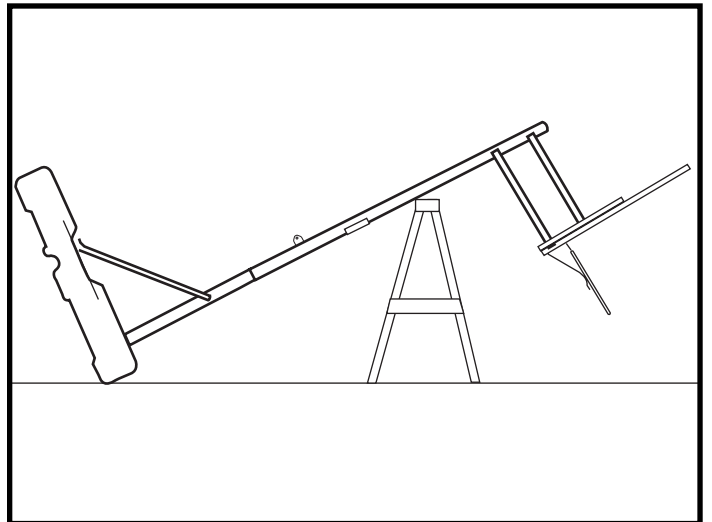
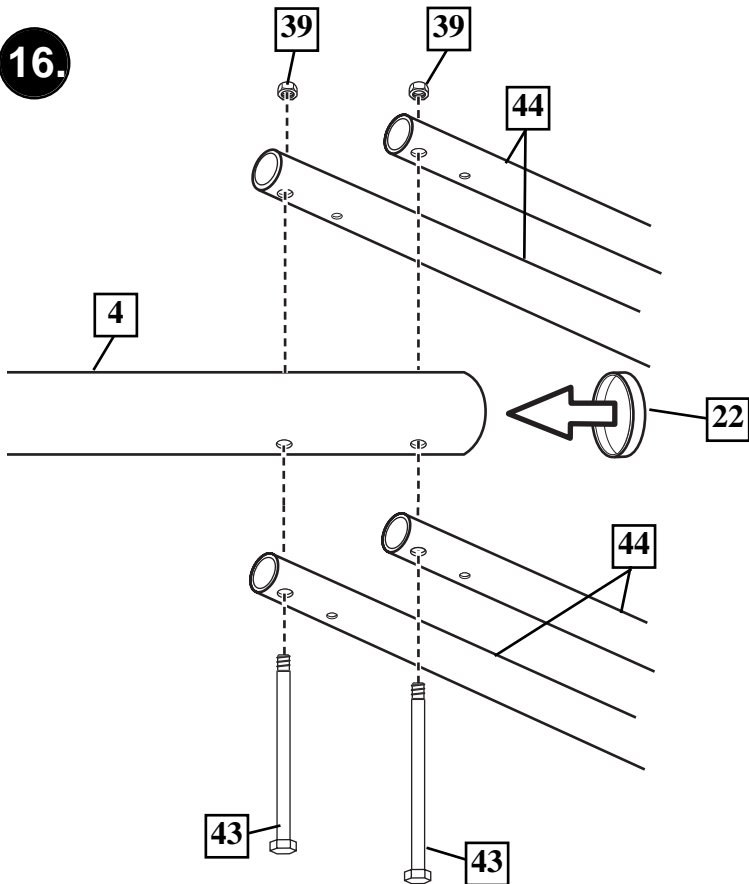

17.

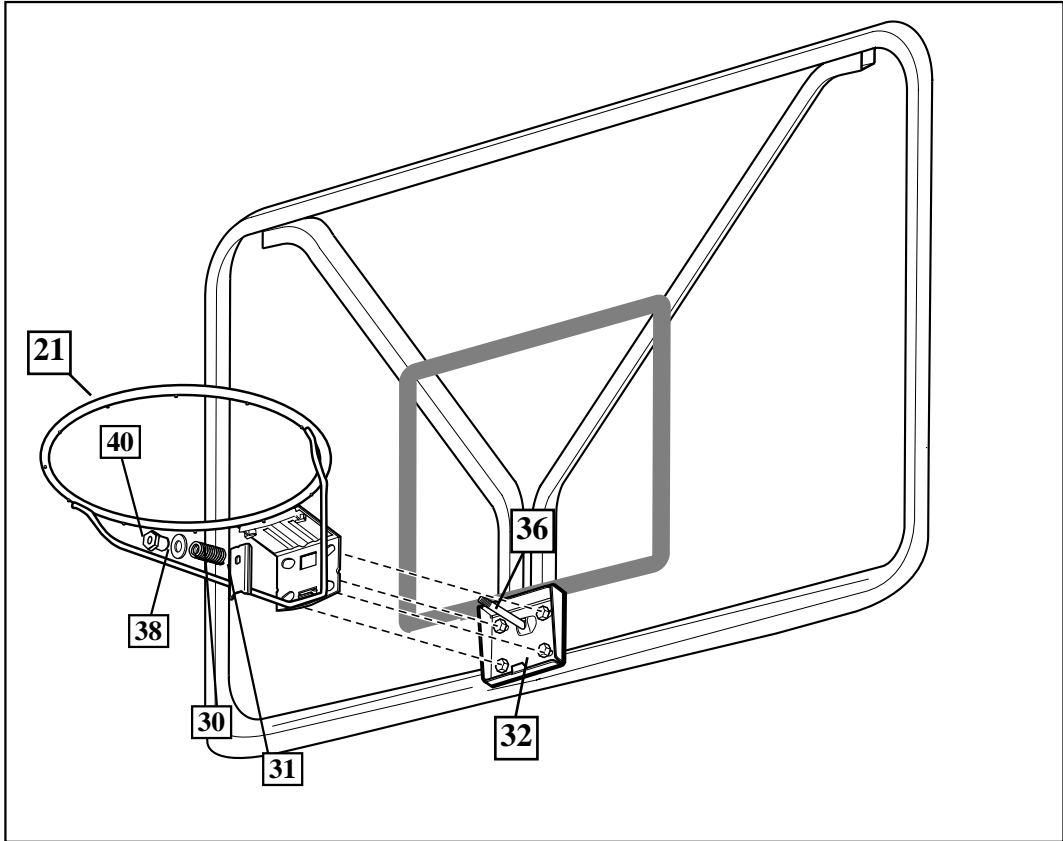

18. Install net clips. Installez les pinces du filet. Netzhalteklammern anbringen. Instale los sujetadores de la red.

! WARNING: Use of this product without proper installation of net clips, or when all net clips are not present could result in bodily harm. Be sure to follow directions carefully.

AVERTISSEMENT : L'utilisation de ce produit sans installer correctement ou toutes les pinces du filet risque de causer des blessures. Veuillez à suivre scrupuleusement les instructions.

WARNUNG: Ein Gebrauch dieses Produkts ohne ordnungsgemäß angebrachte Netzhalteklammern bzw. ohne den Gebrauch der Netzhalteklammern kann Verletzungen nach sich ziehen. Die Anleitung genau befolgen.

ADVERTENCIA: Si este producto se usa con los sujetadores de la red incorrectamente instalados, o si no están todos presentes, se pueden ocasionar lesiones corporales. Asegúrese de seguir cuidadosamente las instrucciones.

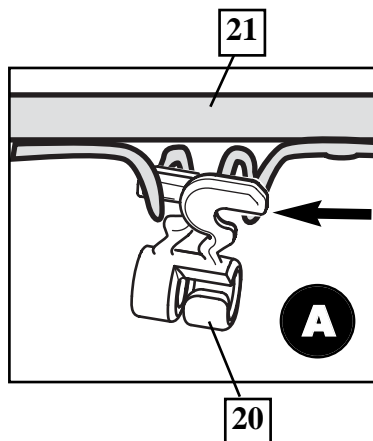
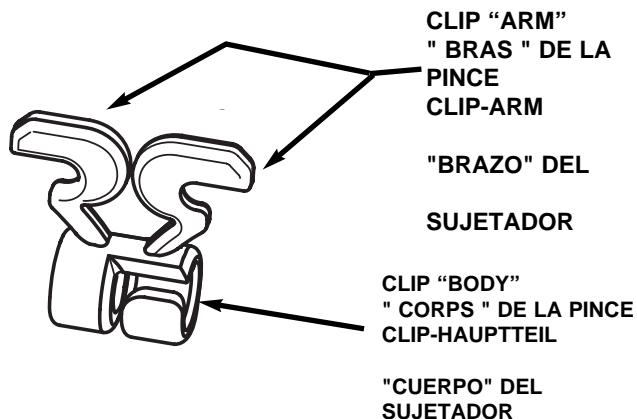

Insert one "arm" of clip (21) into ram (20) as shown. Twist "body" of clip slightly so that second "arm" slides over the top of the first "arm" as shown. Push in direction indicated by arrows.

Insérez un " bras " de la pince (21) dans l'éperon (20), comme illustré. Tournez légèrement le corps de la pince de sorte que le second bras glisse par-dessus le premier, comme illustré.

Einen Arm des Clips (21) wie gezeigt in die Spirale (20) einsetzen. Den Hauptteil des Clips etwas drehen, sodass der zweite Arm wie gezeigt oben über den ersten Arm geschoben werden kann.

Introduzca un "brazo" del sujetador (21) en el accionador (20) como se muestra. Tuerza ligeramente el "cuerpo" del sujetador de manera que el segundo "brazo" se deslice sobre el primer "brazo" como se muestra.

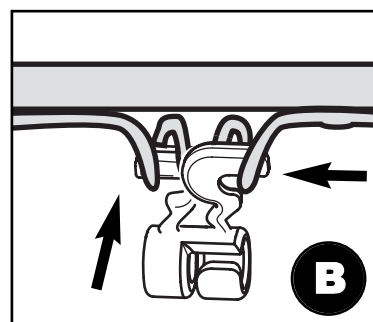

Push second "arm" back and into ram as shown.

Poussez dans le sens des flèches.

In die durch die Pfeile angezeigte Richtung schieben.

Empuje hacia la dirección que indican las flechas.

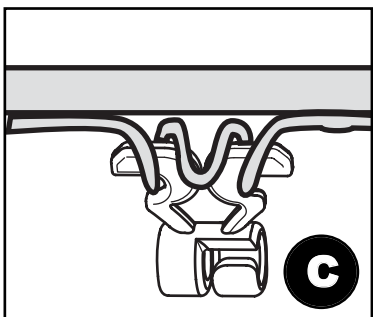

Twist "body" of clip slightly again to spread "arms" of clip. Clip "arms" must be flat and touching edge to edge as shown, not overlapping.

Tournez légèrement le corps de la pince une nouvelle fois pour en étaler les bras.

Den Hauptteil des Clips noch einmal leicht drehen, um die Arme des Clips zu spreizen.

Otra vez tuerza ligeramente el "cuerpo" del sujetador para abrir los "brazos" del sujetador.

19.

Install net.

Installez le filet.

Das Netz anbringen

Instale la red.

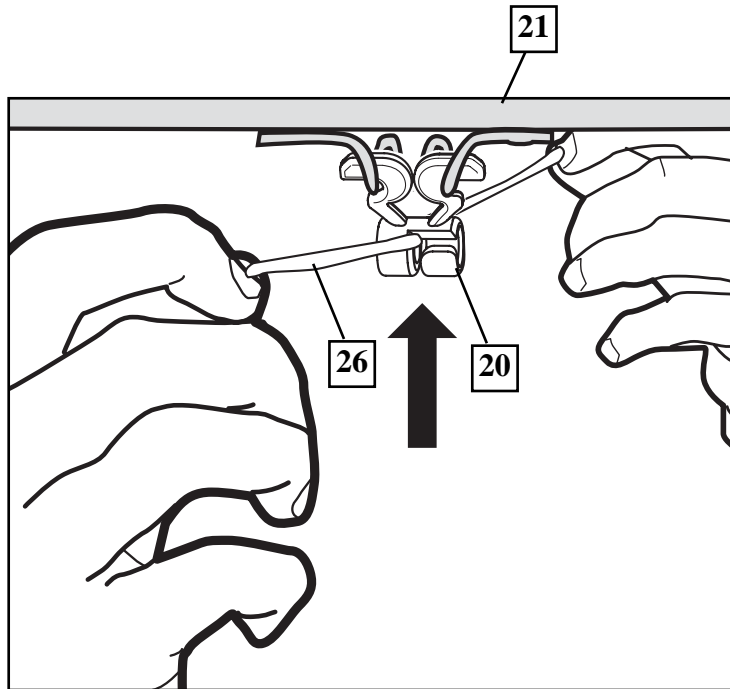

SIDE VIEW
 VUE DE CÔTÉ
 SEITENANSICHT
 VISTA LATERAL

NETCLIP
 PINCE DE FILET
 NETZHALTEKLAMMER
 SUJETADOR DE LA RED

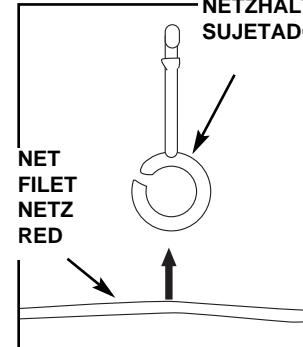

Insert net into bottom of clip as shown.

Insérez le filet dans la base de la pince, comme illustré.

Das Netz wie gezeigt unten in den Clip stecken.

Introduzca la red en la parte inferior del sujetador como se muestra.

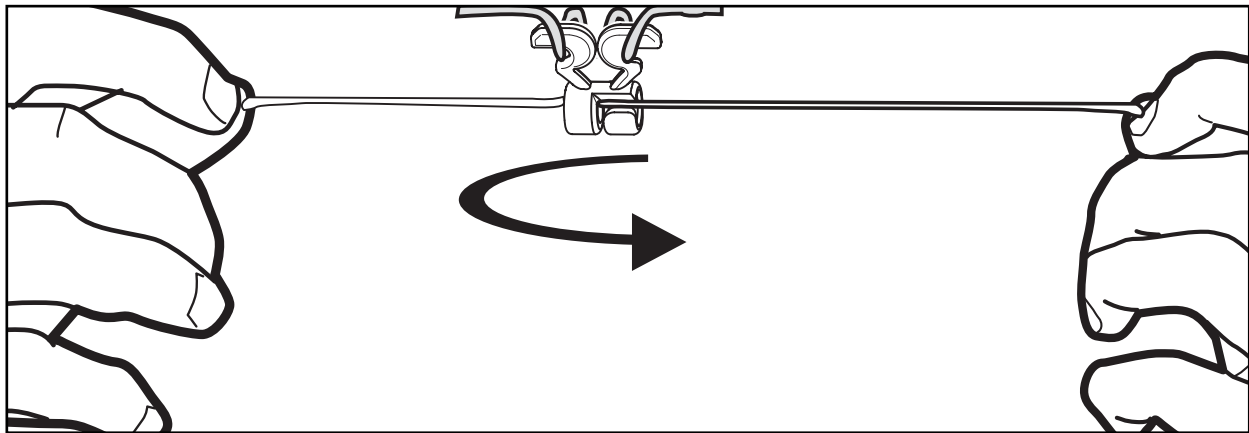

Twist net until it snaps into position.
Net must be centered through clip.

Tournez le filet jusqu'à ce qu'il s'enclenche en position.

Das Netz drehen, bis es einschnappt.

Tuerza la red hasta que quede conectada en su posición.

Le filet doit être centré dans la pince.

Das Netz muss im Clip zentriert werden.

La red debe quedar centrada a través del sujetador.

SIDE VIEW
 VUE DE CÔTÉ
 SEITENANSICHT
 VISTA LATERAL

NETCLIP
 PINCE DE FILET
 NETZHALTEKLAMMER
 SUJETADOR DE LA RED

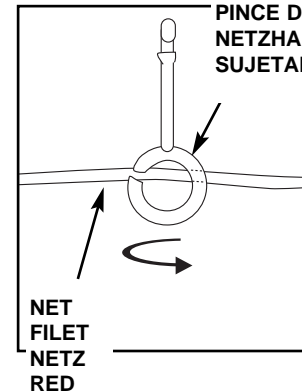

20.

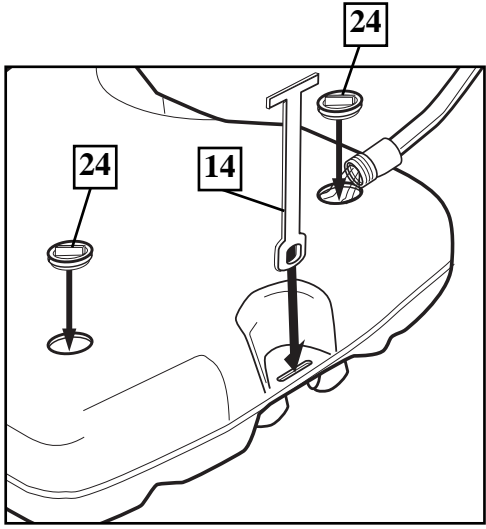

WARNING
SEE TEXT PAGE

IMPORTANT!
(See Text Page)

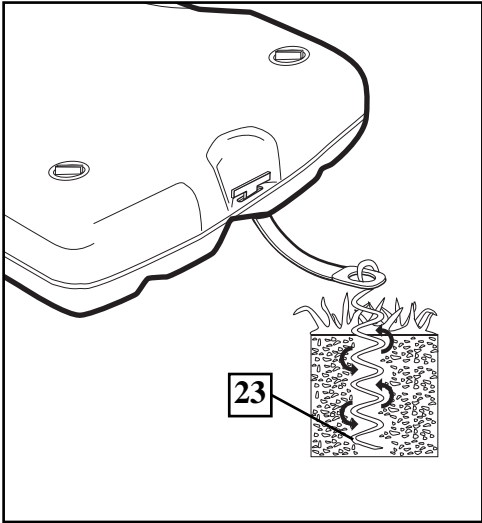

21.

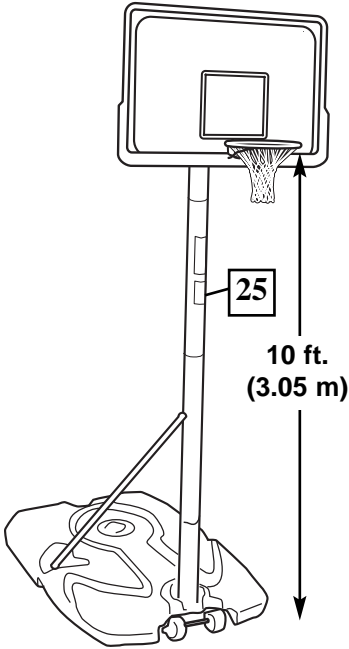

25

HEIGHT ADJUSTMENT

TO ADJUST BACKBOARD:

- TO RAISE BACKBOARD:**
Slowly push up on the rim with broom handle or wooden dowel, 3/4 - 7/8 (19mm - 22mm) diameter as shown to engage locking mechanism at desired height.
- TO LOWER BACKBOARD:**
Push lever up to unlock and carefully lower backboard to lowest position.

MOVING SYSTEM

- Adjust basketball backboard height to lowest position.
- While holding pole, rotate basketball system forward until wheels engage with ground.
- Move basketball system to desired location.
- Carefully rotate basketball system upright.
- Reattach ground restraint and check system for stability.

201257 3/99