

Portable Basketball System Owners Manual

⚠ SAFETY INSTRUCTIONS ⚠

**FAILURE TO FOLLOW THESE SAFETY INSTRUCTIONS MAY
RESULT IN SERIOUS INJURY,
PROPERTY DAMAGE AND WILL VOID WARRANTY.**

***Owner must ensure that all players know and follow these
rules for safe operation of the system.***

To ensure safety, do not attempt to assemble this system without following the instructions carefully. Check entire box and inside all packing material for parts and/or additional instruction material. Before beginning assembly, read the instructions and identify parts using the hardware identifier and parts list in this document. Proper and complete assembly, use and supervision are essential for proper operation and to reduce the risk of accident or injury. A high probability of serious injury exists if this system is not installed, maintained, and operated properly.

- This equipment is intended for home recreational use only and NOT excessive competitive play.
- DO NOT position system near trampolines, diving boards, slides, or any play area equipment. System misuse could cause serious bodily injury.
- Two pole assembly is for in-ground pool side use only.
- Read and understand the warning label affixed to pole.
- The life of your basketball pole depends on many conditions. The climate, placement of the pole, the location of the pole, exposure to corrosives such as chlorine, pesticides, herbicides or salts are all important.
- During assembly, if using a ladder use extreme caution. Two people are recommended for this operation.
- Seat the pole sections properly. Failure to do so could allow the pole sections to separate during play and/or transport of the system.
- Climate, corrosion and excessive use or misuse could result in pole failure.
- Check tank regularly for leakage. Slow leaks could cause system to tip over unexpectedly.
- If technical assistance is required, contact Huff Company Customer Service Center.
- Adult supervision is recommended when adjusting system.

*Most injuries are caused by misuse and/or not following instructions.
Use caution when using this system.*

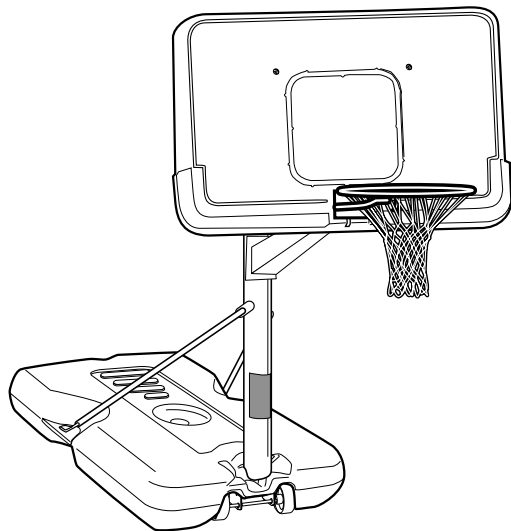

REQUIRED TOOLS AND MATERIALS:

- Two People
- Garden Hose or Sand 360 lb. (163 kg)
- Wrenches: (Two) 1/2" (One) 9/16" or Two Small Adjustable Wrenches
- 9/16" Deep Socket w/Ext. Recommended

IMPORTANT! Have questions?...Don't go back to the store!

We appreciate your purchasing one of our many fine products. We are sure that you will be very satisfied with your selection. Although great care and effort have been taken, occasionally problems may occur. To ensure prompt and correct handling of any problems, or to answer any questions, please contact our Toll-Free Customer Service Number listed below. **Service will be quicker if you have your Model Number (found on carton) and assembly instructions ready when calling. PLEASE WRITE YOUR MODEL NUMBER IN THE SPACE PROVIDED ABOVE.**

Toll-Free Customer Service Number for U.S: **1-800-558-5234** and Canada Only: **1-800-284-8339**
Internet Address: <http://www.huffysports.com>

HARDWARE IDENTIFIER

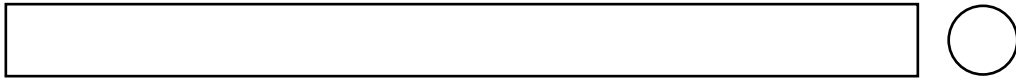

Item #5 (1)

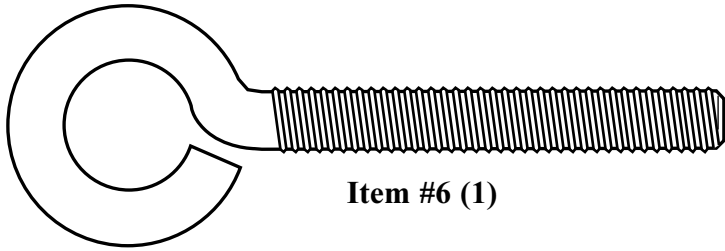

Item #6 (1)

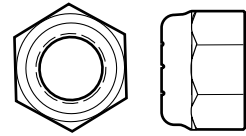

Item #8 (5)

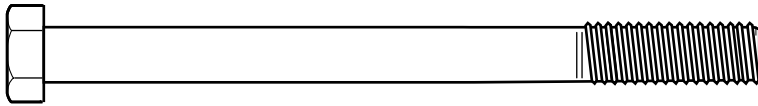

Item #9 (1)

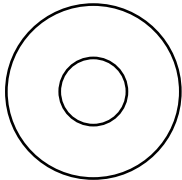

Item #10 (6)

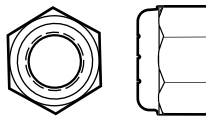

Item #12 (1)



Item #14 (2)

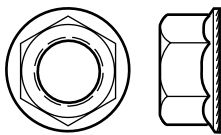

Item #15 (10)



Item #17 (12)

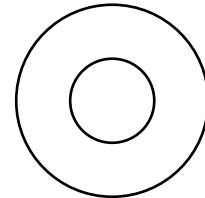

Item #19 (8)

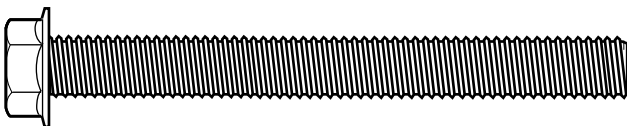

Item #20 (4)

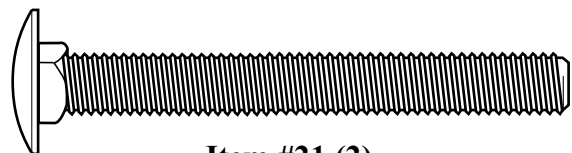

Item #21 (2)

* You may have extra parts with this model.

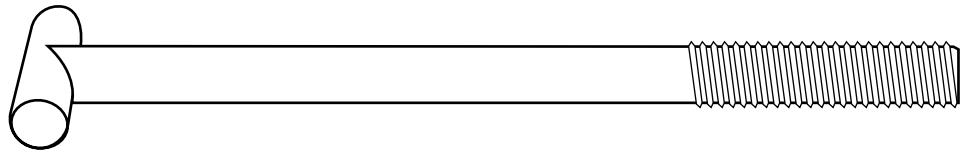

Item #32 (1)

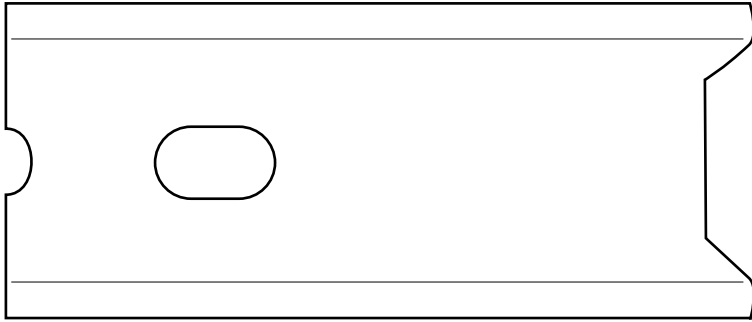

Item #33 (1)

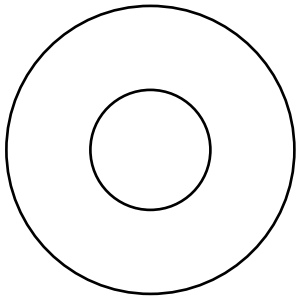

Item #35 (1)

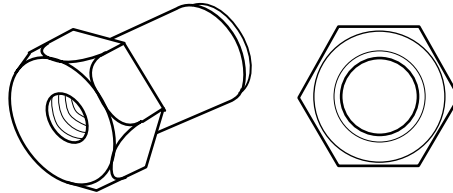

Item #36 (1)

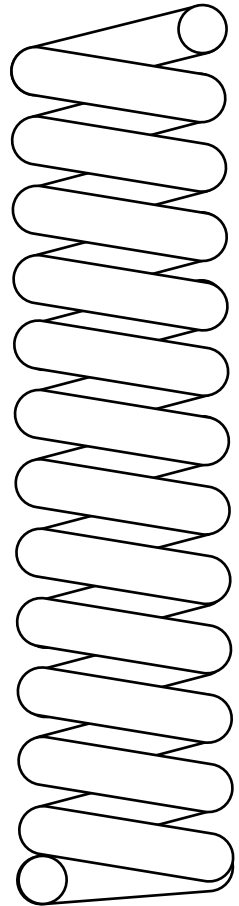

Item #34 (1)

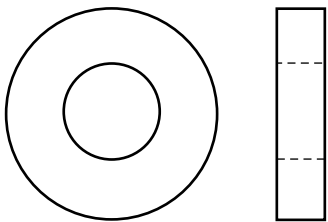

Item #26 (2)



Item #41 (2)



Item #38 (4)

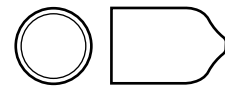

Item #43 (6)*

* You may have extra parts with this model.

ENGLISH INSTRUCTIONS
IMPORTANT! WRITE DOWN MODEL NUMBER FROM BOX ON
PAGE 1 OF THIS OWNERS MANUAL



Questions or Missing Parts?

DON'T go back to store!

Call TOLL-FREE Customer Service
Number listed on the front page!

1. Remove contents from tank (1).
2. Install rod (5) through holes in bottom pole section (4) and eyebolt (6).
3. Install wheel axle (2) through wheel carriage (7) and install wheels (3) onto wheel axle (2) with spacers (26) as shown. Insert pole assembly into tank assembly as shown. Secure bottom pole (4) to tank and wheel bracket as shown, a deep socket is recommended. **NOTE:** Two people recommended for this step. **IMPORTANT! DO NOT OVER TIGHTEN.**
4. Secure tank struts (11) to pole. Rotate non-secured ends of tank struts (11) outward to mounting holes in tank as shown.
▲ WARNING: TIGHTEN BOLT (11) IN LOCK NUT (14) UNTIL FLUSH (EVEN) WITH LOCK NUT'S OUTER EDGE.
5. Secure non-secured ends of tank struts (11) to tank as shown. Repeat for opposite side.
6. Attach extension arm (18) to pole using U-bolt (22), washers (19), nuts (8), as shown. Install pole cap (24) as shown.
▲ WARNING: DO NOT LEAVE ASSEMBLED UNIT UNATTENDED, IT MAY TIP OVER.
7. Attach board struts (29) to extension arm using U-bolts (30), strap (42), and nuts (15) and bolt covers (43) as shown. Tighten completely.
8. Attach backboard to struts (29) with bolts (21) and nuts (15) as shown.
Insert T-bolt (32) through back bracket (31) and attach this assembly to backboard by inserting bolts (20) through back bracket (31), backboard, backboard extension arm (18), washers (19), and nuts (15) as shown.
IMPORTANT! Prevent backboard lighting wires from being damaged by keeping them in the small channel on backboard.
9. **A.** Fit rim (16) securely into bracket (31) as shown.
B. Install reinforcement bracket (33) onto "T" bolt (32) as shown. Tuck wires from rim behind reinforcement bracket (33).
C. Install spring (34) onto "T" bolt (32) as shown.
D. Install special nut (36) and washer (35) onto "T" bolt (32).
Tighten nut (36) until flush with end of "T" bolt (32).
10. Connect red and black wires from rim (16) to red and black wires from rim cover (37). Repeat with blue and white wires.
11. Fit rim cover (37) into rim bracket (31) and secure to rim with screws (38) as shown.
12. Remove paper backing from battery cover gasket (39) and

adhere gasket (39) to inside of battery cover (40) as shown. Install 2 "AA" batteries (not included) into rim cover (37). Be sure to install batteries in direction shown on inside of battery compartment. Attach battery cover (40) with screws (38) and washers (41) as shown. Turn unit on to verify correct battery installation. **NOTE:** The lighted feature of this product is designed for night time use in order to extend playing time after dark, and may not be readily visible during day light.

▲ WARNING: USE OF THIS PRODUCT WITHOUT PROPER INSTALLATION OF SMART CLIPS, OR WHEN ALL SMART CLIPS ARE NOT PRESENT COULD RESULT IN BODILY HARM. BE SURE TO FOLLOW DIRECTIONS CAREFULLY.

13. Install net clips as shown. (See illustration)

14. Install net as shown. (See illustration)

15. Carefully upright assembly. Apply moving system label (13) to front of pole as shown.

▲ WARNING: DO NOT LEAVE ASSEMBLED UNIT UNATTENDED WHEN EMPTY, MAY TIP OVER.

16. Place assembled unit to desired location. Fill tank with water (30 gallons (114 liters)) or sand (360 lb. (163 kg)) and snap tank cap (28) in place.

Insert T-strap (27) through slot on back of base as shown. Secure unit to ground by twisting tie down stake (25) into ground and hooking T-strap (27) onto tie down stake (25).

IMPORTANT! Add two gallons (7.6 liters) of non-toxic antifreeze in sub-freezing climates.

WARRANTY CARD:

Please remember to complete your product registration form either on-line at:
www.huffysports.com/warrantycard or mail-in the enclosed postcard.

PARTS LIST - See Hardware Identifier

| <u>Item</u> | <u>Qty.</u> | <u>Part No.</u> | <u>Description</u> |
|--------------------|--------------------|------------------------|--|
| 1 | 1 | 206740 | Tank (White) |
| 2 | 1 | 200628 | Wheel Axle |
| 3 | 2 | 226401 | Wheel |
| 4 | 1 | 986102 | Bottom Pole Section |
| 5 | 1 | 202820 | Rod, 3/8 O.D. x 4-3/4 Long |
| 6 | 1 | 202822 | Eye Bolt, 3/8-16 x 3-3/4 Long |
| 7 | 1 | 200627 | Wheel Bracket |
| 8 | 5 | 203063 | Lock Nut, Nylon Insert, 3/8-16 |
| 9 | 1 | 202541 | Bolt, Hex Head, 5/16-18 x 3-3/4 |
| 10 | 6 | 203218 | Washer, 5/16 Flat |
| 11 | 2 | 986206 | Tank Strut |
| 12 | 1 | 203220 | Lock Nut, 5/16-18 |
| 13 | 1 | 201261 | Label, Moving System |
| 14 | 2 | 203156 | Bolt, Hex Head, 5/16-18 x 1 Long |
| 15 | 10 | 203100 | Nut, Hex Flange 5/16-18 |
| 16 | 1 | | Rim |
| 17 | 12 | 201219 | Smart Clip |
| 18 | 1 | 902006 | Extension Arm, White |
| 19 | 8 | 203309 | Washer, 1 O.D. |
| 20 | 4 | 203113 | Bolt, Hex Flange, 5/16-18 x 2-1/2 Long |
| 21 | 2 | 203038 | Bolt, Carriage 5/16-18 x 2-3/4 |
| 22 | 2 | 201562 | U-bolt, Round, 3/8-16 x 2-3/4 Long |
| 23 | 1 | | Net |
| 24 | 1 | 201190 | Cap |
| 25 | 1 | 203124 | Tie Down Stake |
| 26 | 2 | 201651 | Spacer, Wheel Axle |
| 27 | 1 | 201568 | T-Strap |
| 28 | 1 | 201189 | Tank Cap |
| 29 | 2 | 906706 | Strut, Backboard |
| 30 | 1 | 201546 | U-bolt, Square, 5/16-18 x 3-3/4 Long |
| 31 | 1 | 900033 | Back Bracket |
| 32 | 1 | 203796 | T-Bolt, 3/8-16 |
| 33 | 1 | 200318 | Reinforcement Bracket, Slam Jam Rim |
| 34 | 1 | 203472 | Spring |
| 35 | 1 | 203470 | Washer, 1.5 O.D. |
| 36 | 1 | 203795 | Nut, Special 3/8-16 |
| 37 | 1 | 200822 | Rim Cover |
| 38 | 4 | 200720 | Phillips Washer Head Screw, #8 x 1/2" |
| 39 | 1 | 200713 | Gasket, Battery Cover |
| 40 | 1 | 200712 | Battery Cover |
| 41 | 2 | 200825 | Washer, Plastic |
| 42 | 1 | 203297 | Strap, U-bolt |
| 43 | 6 | 200516 | Bolt Covers, Black Vinyl |

* You may have extra parts with this model.



Questions or Missing Parts?

DON'T go back to store!

Call TOLL-FREE Customer Service
Number listed on the front page!

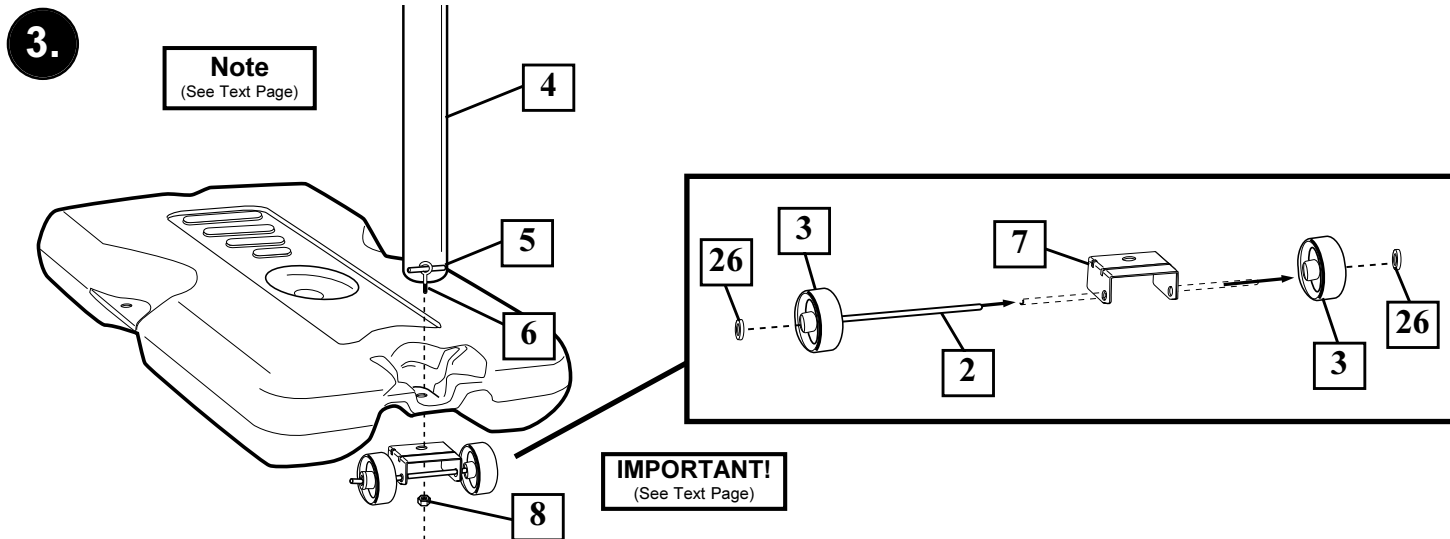
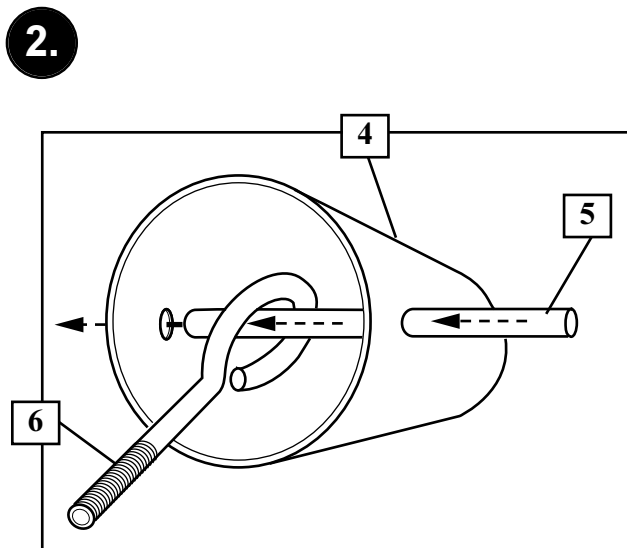
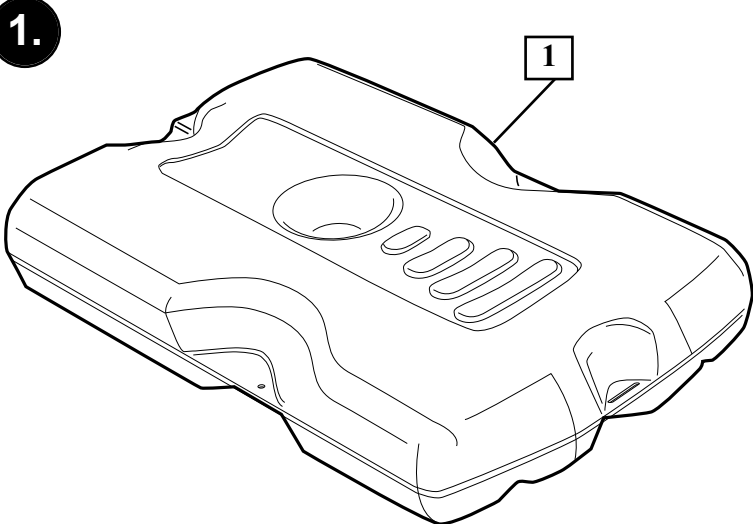

IMPORTANT!
(See Text Page)

4.

⚠WARNING
(See Text Page)

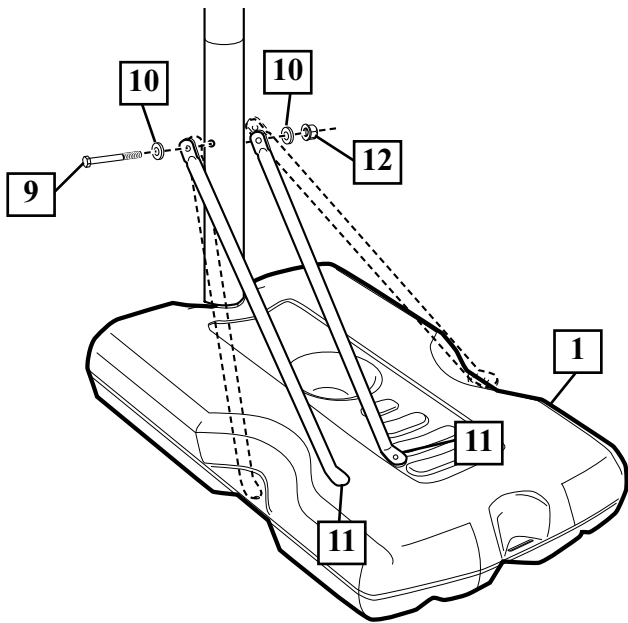

5.

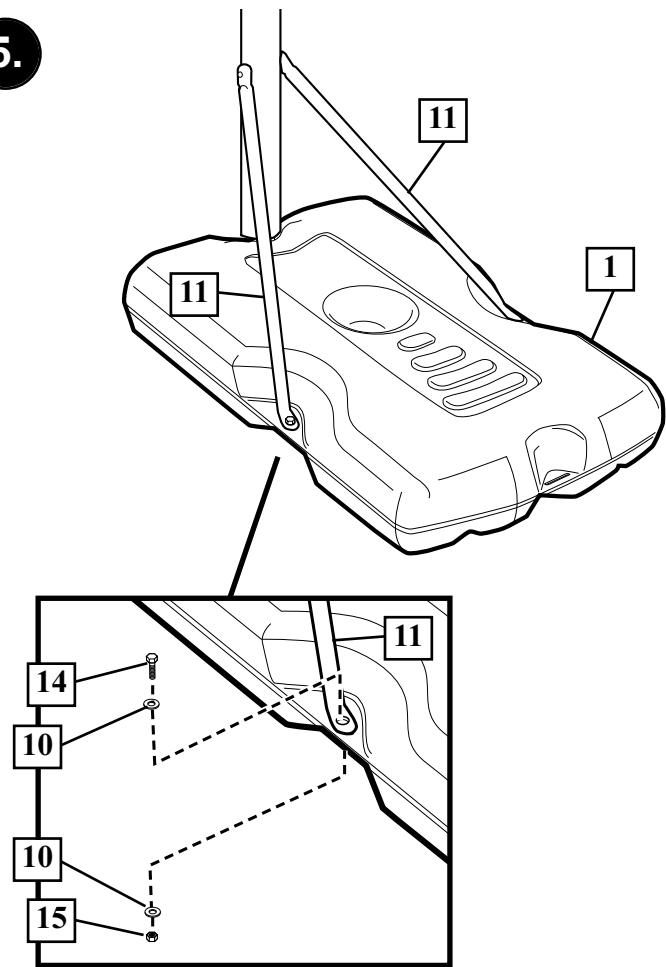

6.

⚠WARNING
(See Text Page)

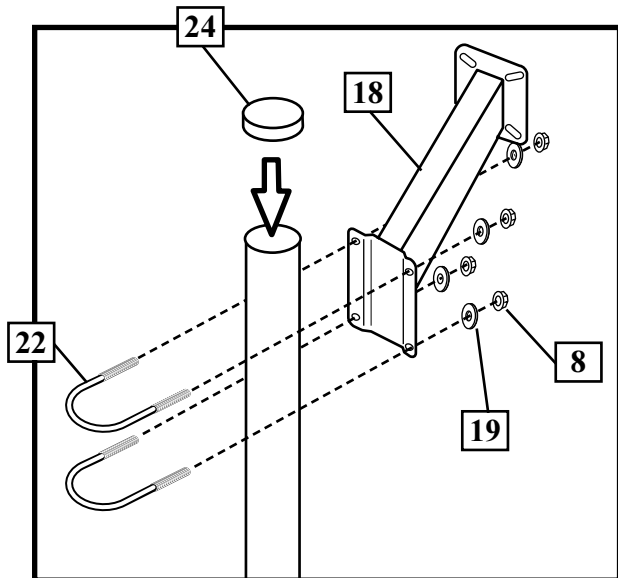

7.

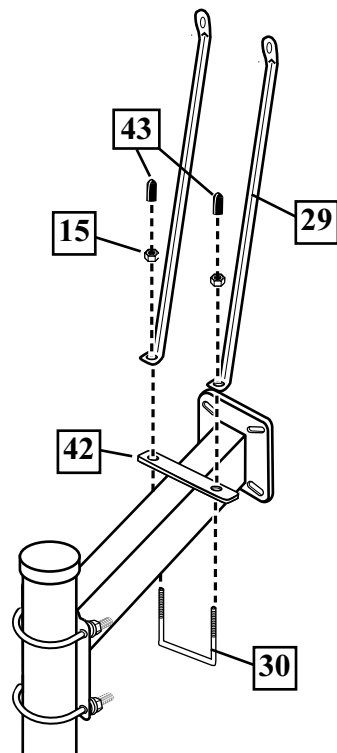

BOARD MOUNTING

8.

IMPORTANT!
(See Text Page)

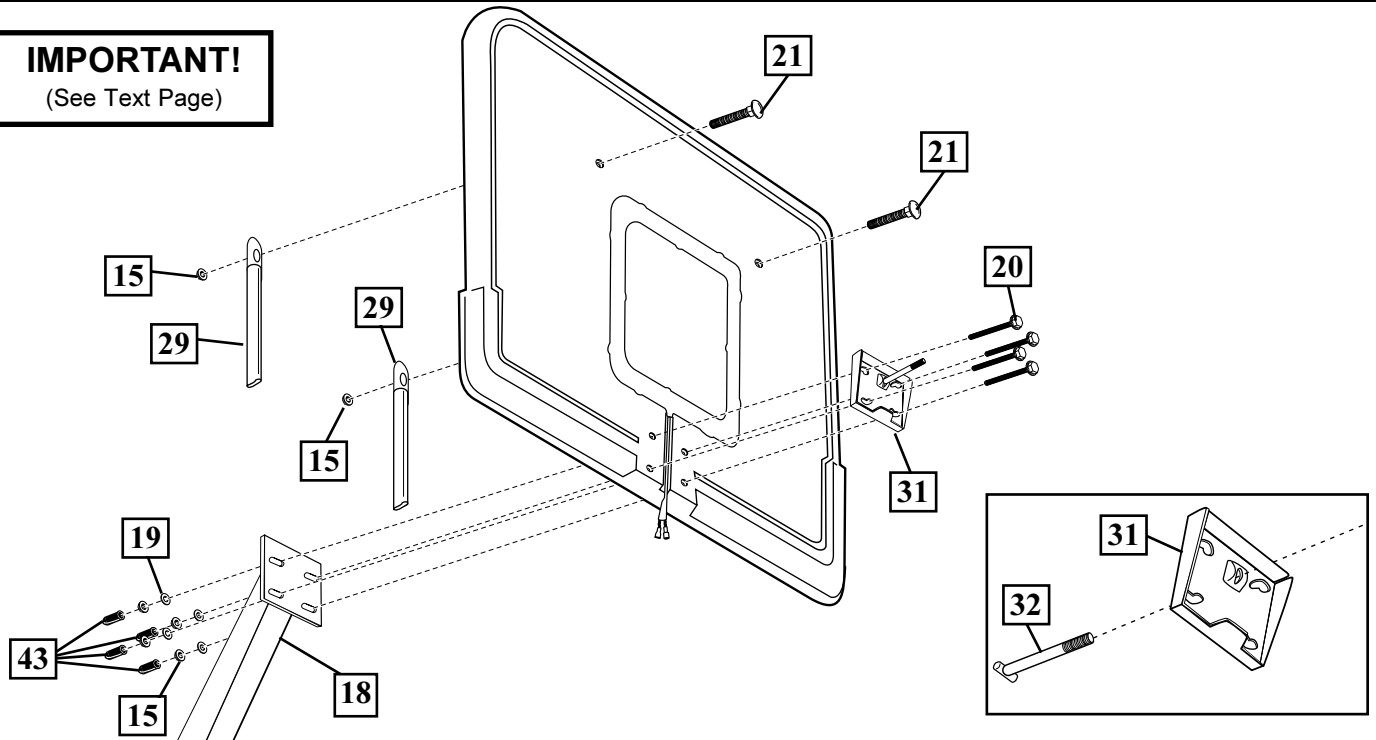

9.

A

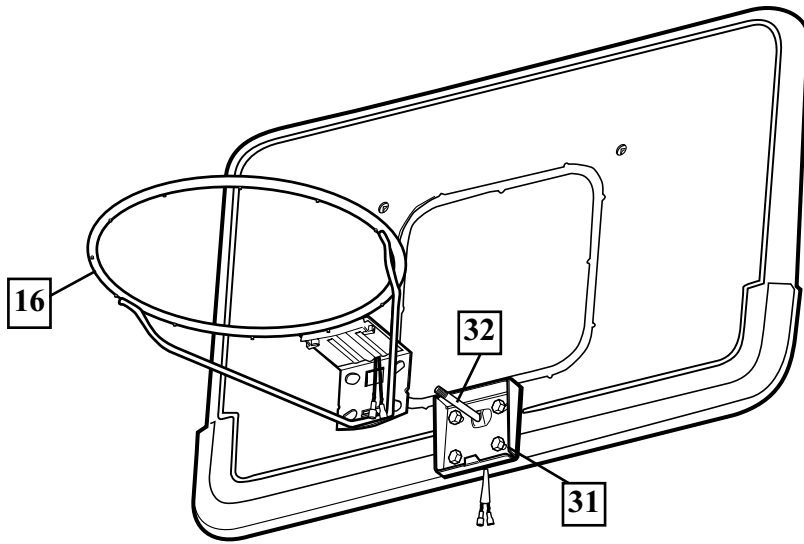

9.

B

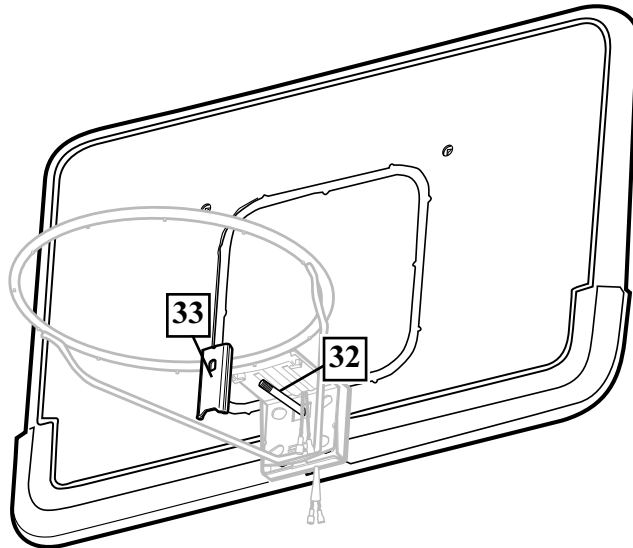

9.

C

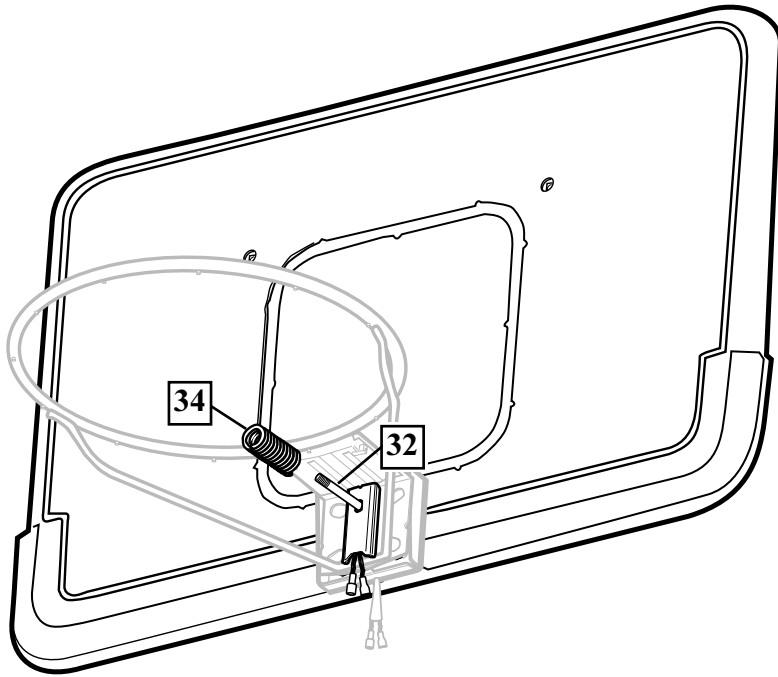

9.

D

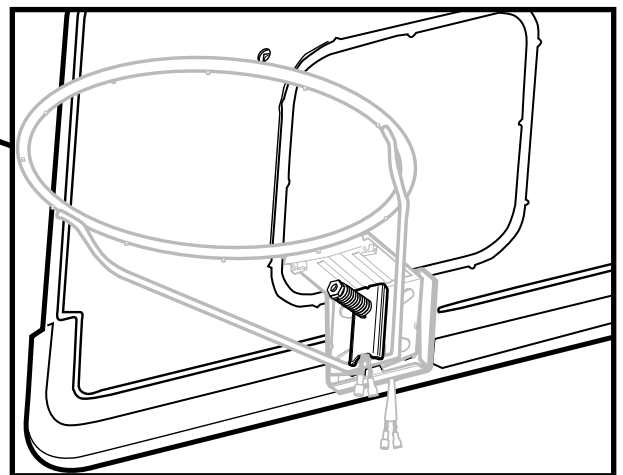
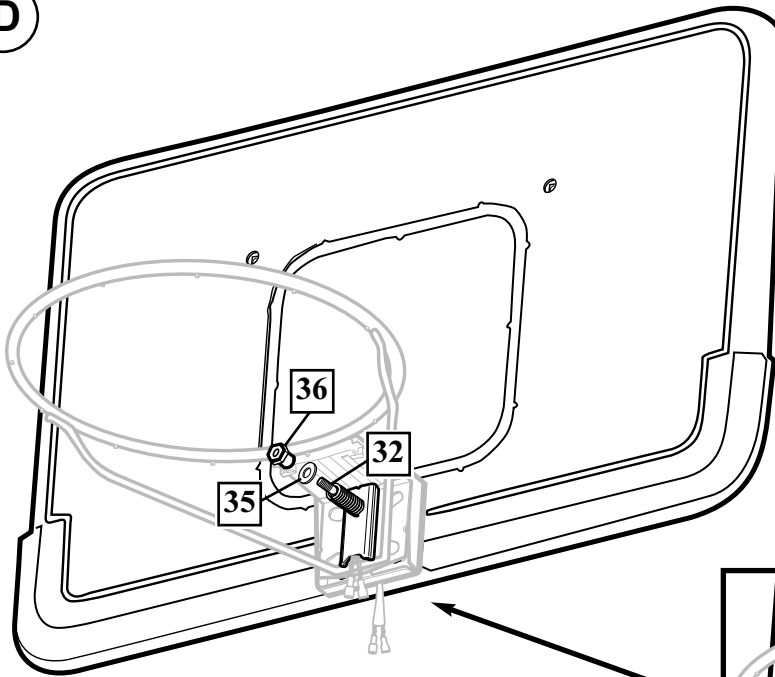

10.

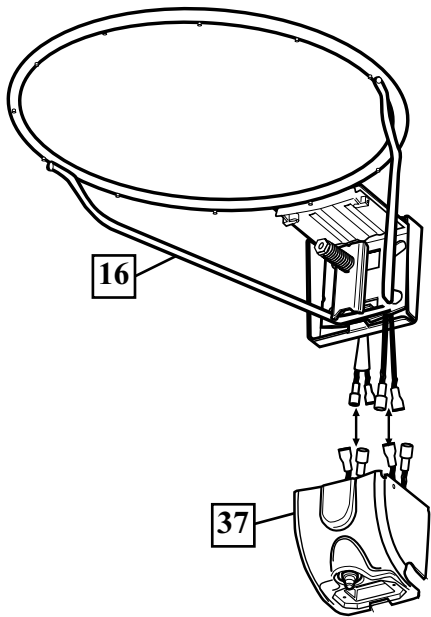

11.

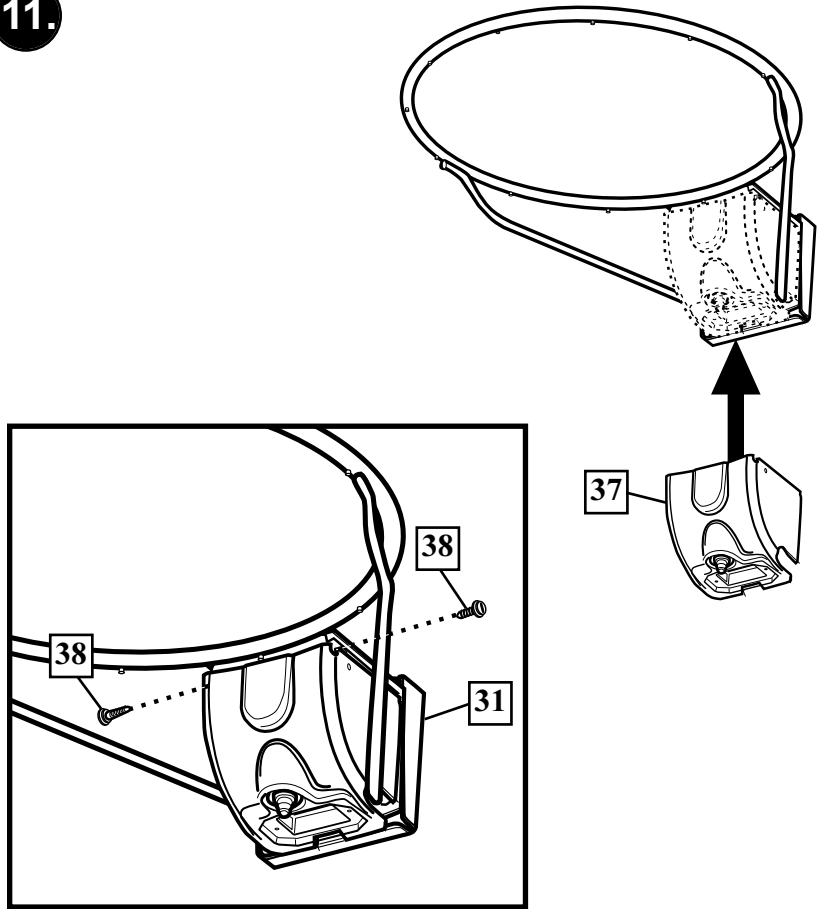

12.

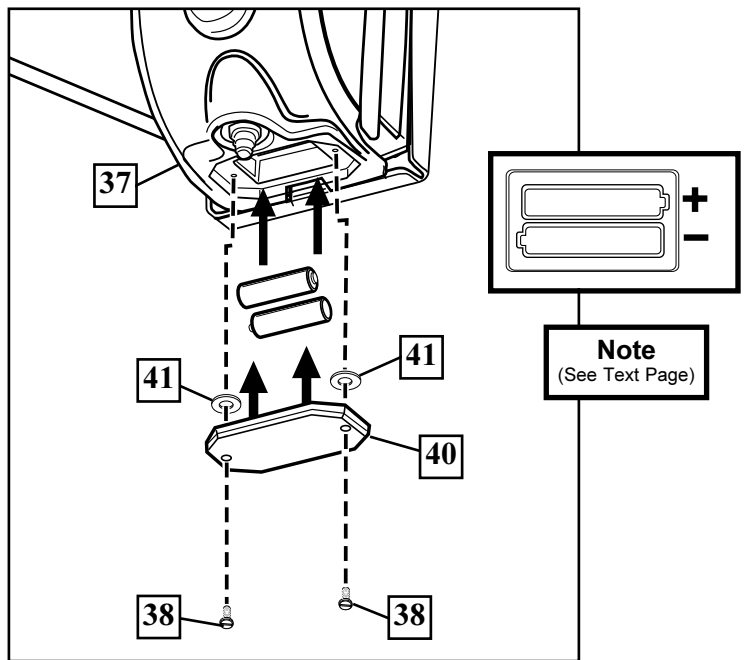
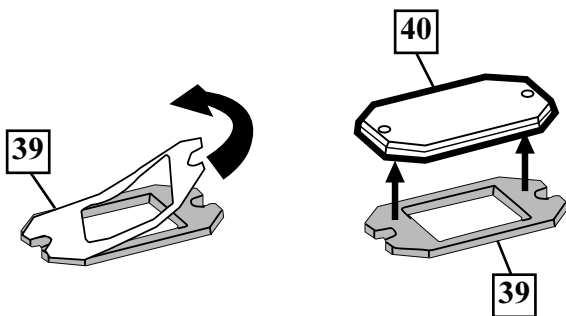

NOTE: The lighted feature of this product is designed for night time use in order to extend playing time after dark, and may not be readily visible during day light.

IMPORTANT!
SEE TEXT PAGE

13 Install net clips.

! WARNING: Use of this product without proper installation of net clips, or when all net clips are not present could result in bodily harm. Be sure to follow directions carefully.

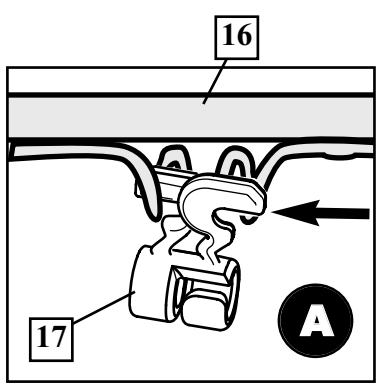
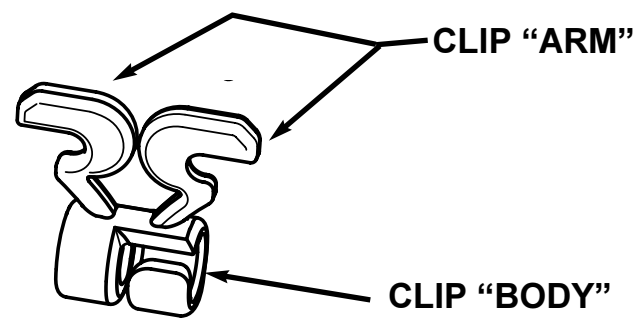

Insert one "arm" of clip into ram as shown. Twist "body" of clip slightly so that second "arm" slides over the top of the first "arm" as shown. Push in direction indicated by arrows.

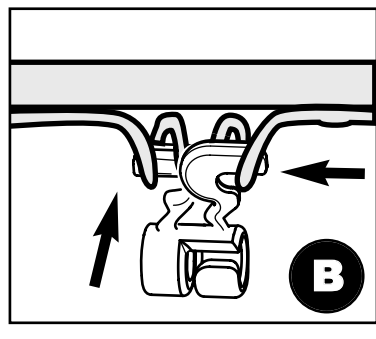

Push second "arm" back and into ram as shown.

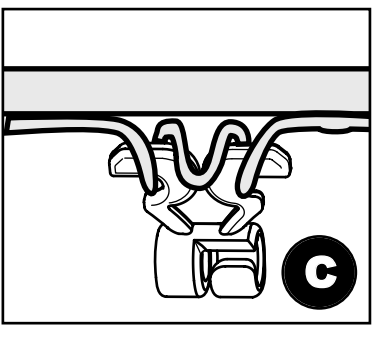

Twist "body" of clip slightly again to spread "arms" of clip. Clip "arms" must be flat and touching edge to edge as shown, not overlapping.

NET INSTALLATION

14.

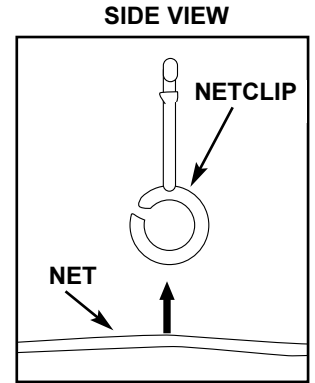
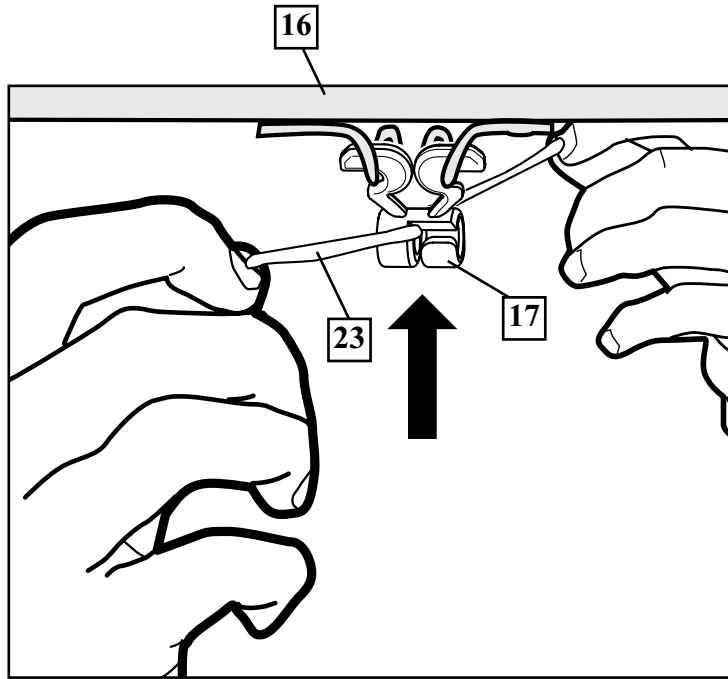

Insert net into bottom of clip as shown.

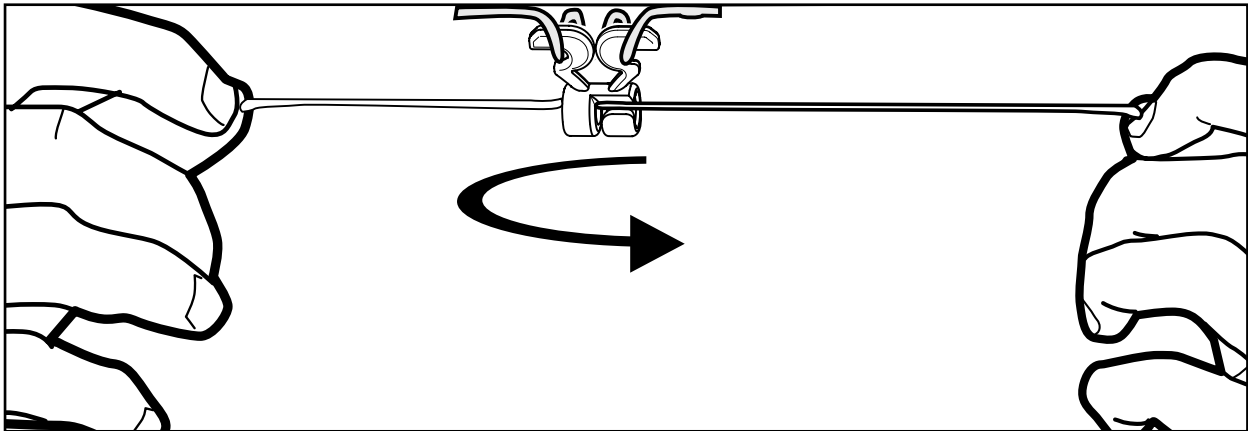

Twist net until it snaps into position.
Net must be centered through clip.

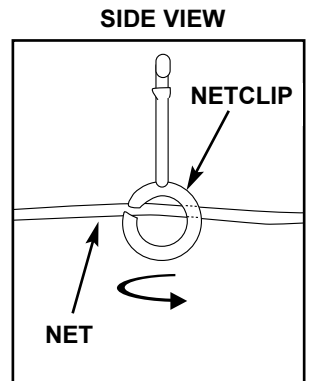

15.

⚠ WARNING
(See Text Page)

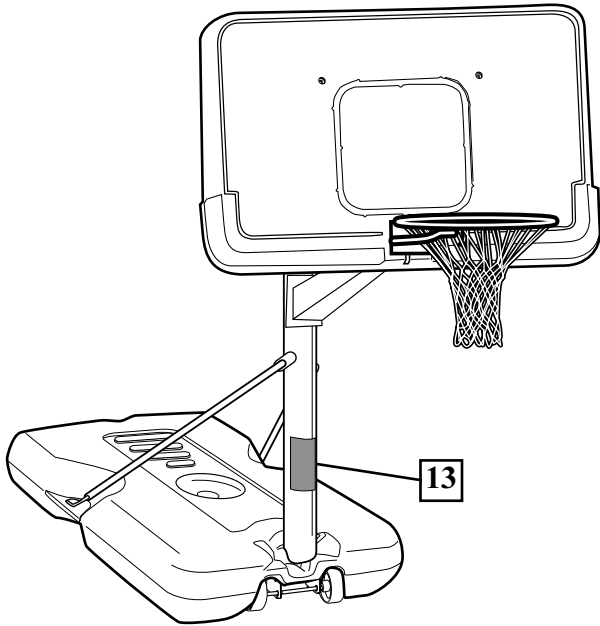

16.

IMPORTANT!
(See Text Page)

