

# HUFFY<sup>®</sup>SPORTS

## Display System Owners Manual

Customer Service Center

• N53 W24700 South Corporate Circle • Sussex, WI 53089 • U.S.A.

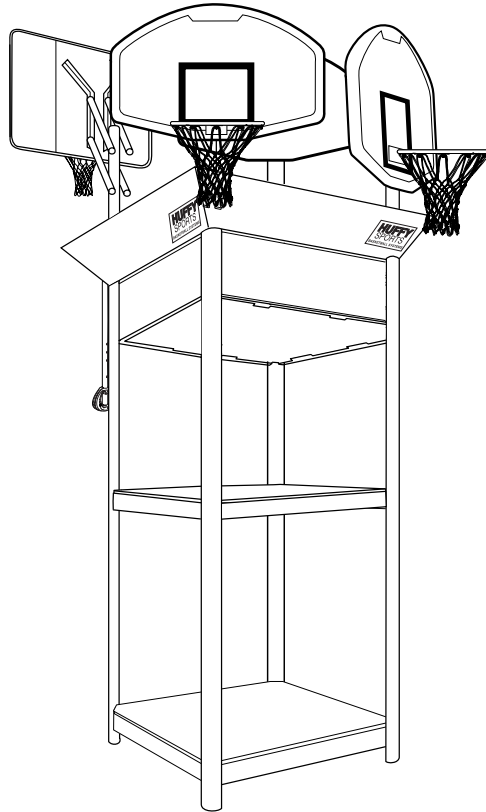

**Models  
89225  
&  
89226**



### **! WARNING!**

**READ AND UNDERSTAND  
OPERATOR'S MANUAL  
BEFORE USING THIS UNIT.**

**FAILURE TO FOLLOW  
OPERATING INSTRUCTIONS  
COULD RESULT IN INJURY  
OR DAMAGE TO PROPERTY.**

### **REQUIRED TOOLS AND MATERIALS:**

- 2 People
- Wrenches: (Two each) 7/16", 1/2", 9/16", and 3/4" or Pliers
- Phillips Screwdriver
- 2 Step Ladders, 8 ft. (2.4 m)

### **IMPORTANT!**

To ensure prompt and correct handling of any problems, or to answer any questions, please contact the Sample and Display Technician at 1-800-558-5234.

# BEFORE YOU START!

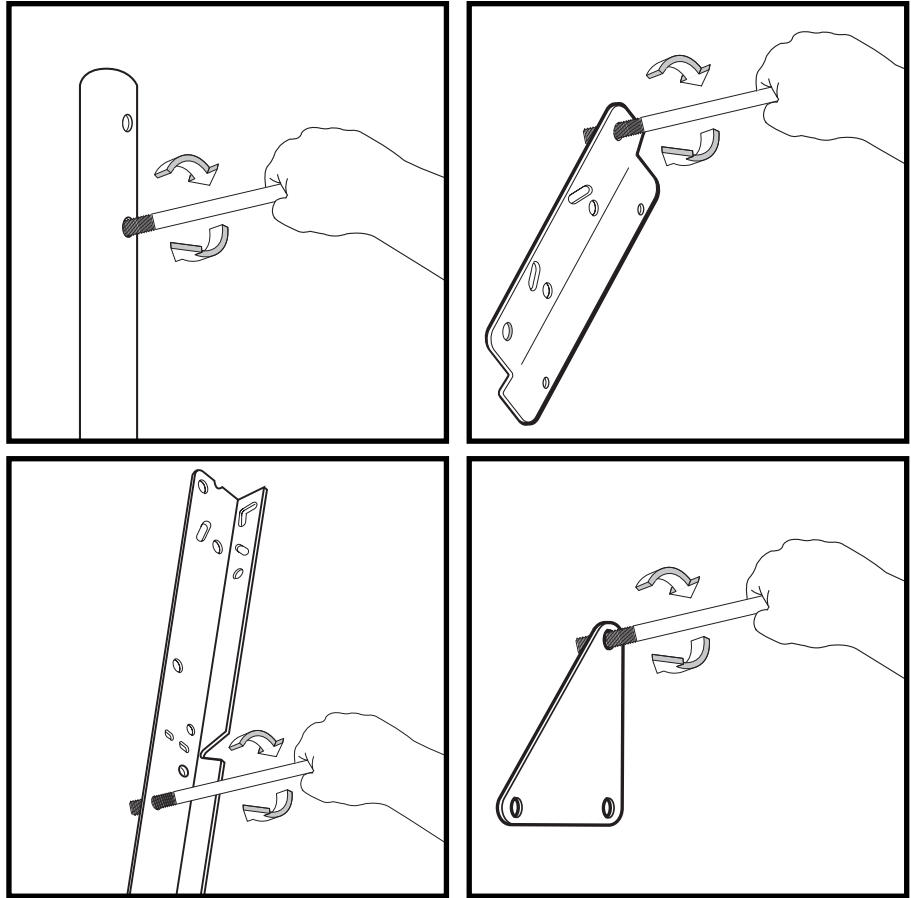

**To ensure optimal playability of backboard system, a close tolerance fit between the elevator components and hardware is required. Test fit large bolts into large holes of elevator tubes, backboard brackets and triangle plates. Carefully rock them in a circular motion to ream out any excess paint from holes if necessary.**

## **AVANT DE COMMENCER !**

Pour garantir l'utilisation optimale du panneau, les composants du système élévateur et la visserie doivent être bien ajustés (serrés). À titre d'essai, insérez les gros boulons dans les gros trous des tubes du système élévateur, des supports du panneau et des plaques triangulaires. Basculez-les avec précaution en imprimant un mouvement circulaire pour éliminer l'excédent de peinture, si nécessaire.

## **¡ANTES DE COMENZAR!**

Para asegurar el óptimo rendimiento del sistema del respaldo en el juego, se requiere un ajuste de tolerancia estrecha entre los componentes del elevador y el herraje. Pruebe el ajuste de los pernos grandes en los orificios grandes de los tubos elevadores, soportes del respaldo y placas triangulares. Cuidadosamente muévalos en círculos para eliminar cualquier exceso de pintura, si es necesario.

## **VORBEREITENDE MASSNAHMEN**

Um sicherzustellen, dass das Korbwandssystem optimal für den Spielbetrieb geeignet ist, müssen die Komponenten der Verlängerungsvorrichtung und die verschiedenen Befestigungsteile fest miteinander verschraubt werden. Große Schrauben zur Probe in die großen Löcher der Verlängerungsröhre, Korbwandklammern und Dreiecksplatte stecken und diese vorsichtig in einer Kreisbewegung hin- und herbewegen, um eventuelle Farbrückstände aus den Bohrungen zu entfernen.

## NOTICE TO ASSEMBLERS

ALL Huffy Sports Basketball Systems, including those used for DISPLAYS, MUST be assembled and ballasted with sand or water according to the instructions. Failure to follow instructions could result in **SERIOUS INJURY**. It is **NOT** acceptable to devise a makeshift weight system.

### IMPORTANT!

Remove all contents from boxes.  
Be sure to check inside pole sections;  
hardware and additional parts are packed inside.

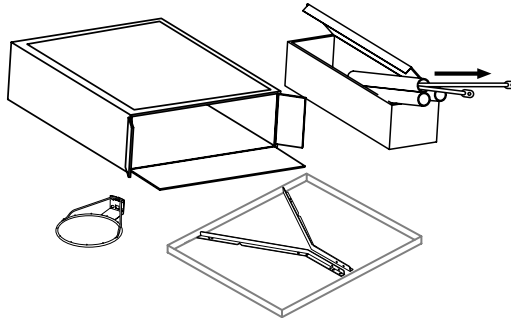

## ! SAFETY INSTRUCTIONS !

**FAILURE TO FOLLOW THESE SAFETY INSTRUCTIONS MAY  
RESULT IN SERIOUS INJURY,  
PROPERTY DAMAGE AND WILL VOID WARRANTY.**

***This unit is intended for display purposes only and  
should not be used for play.***

To ensure safety, do not attempt to assemble this system without following the instructions carefully. Check entire box and inside all packing material for parts. Before beginning assembly, read the instructions and identify parts in this document. Proper and complete assembly, use and supervision is essential for proper operation and to reduce the risk of accident or injury. A high probability of serious injury exists if this system is not installed, maintained, and operated properly.

- During assembly, if using a ladder use extreme caution. Two people are recommended for this operation.
- If technical assistance is required, contact Huffy Sports' Sample and Display Technician.
- Serious injury could occur if teeth/face come in contact with backboard, net or rim.
- Display recommended for 3" (7.6 cm) or 3-1/2" (9 cm) Round or 4" (10 cm) Square poles only.
- All instructions and warnings **MUST** accompany any display item that is sold.

*Most injuries are caused by misuse and/or not following  
instructions.*

*Use caution when installing this unit.*

# PARTS LIST (See Hardware Identifier)

<u>Item</u>	<u>Qty.</u>	<u>Part No.</u>	<u>Description</u>	<u>Item</u>	<u>Qty.</u>	<u>Part No.</u>	<u>Description</u>
1	2	900033	Back Bracket	35	2	203795	Nut, Slam Jam
2	2	203796	T-Bolt, 3/8-16 x 5	36	1	201125	Spring, Rathet return
3	2	200318	Bracket	37	2	900103	Bracket, Backboard Support
4	2	203472	Spring	38	2	200874	Spacer, Steel .402 I.D.x.50 O.D.x1.5 Long
5	2	201651	Spacer, .50 I.D. x .25 Long	39	6*	205528	Bolt, Hex Flange, 5/16-18 x 1 Long
6	2	206303	Washer, 1/4" Flat	40	4	201642	Spacer .530 I.D. x.63 O.D. x .875 Long
7	8*	203113	Bolt, Hex-Flange 5/16-18 x 2.5	41	2	206219	Pole Cap
8	21	203100	Nut, Hex-Flange 5/16-18 whiz Lock	42	10	206340	Lock Nut, Hex Head, 1/2-13
9	48	201219	Clip, Smart Clips	43	1	202814	Cap, Pole Top
10	1	990062	Pole, 3-1/2"	44	3	203038	Bolt, Carriage 5/16-18 X 2-3/4
11	1	904847	Pole, Display, 3" O.D. x 43" Long	45	1	204855	Handle, Left
12	3	206987	Wedge	46	1	204856	Handle, Right
13	2	203798	Bolt, Hex 5/16-18 x 1.5" Long	47	1	904833	Height Adjustment Rod
14	1	900217	Pole, Display	48	1	204872	Label, Height Indicator
15	2	201129	Spacer, 1-3/4" Long	49	1	204832	Bracket, Pole Mount
16	2	203231	Bolt, Carriage, 5/16-18 x 3.5" Long	50	1	900060	Pole, Display
17	5	201124	Lock Nut, Hex Head, 3/8-16	51	2	204857	Spacer, Metal 1/2" O.D.x1.44 Long
18	1	240017	Bolt, Hex Head 1/4-20 x 2 1/4	52	2	204858	Spacer, Biscuit, Plastic
19	1	201160	Pawl Lever	53	1	900253	Backboard Mounting Bracket
20	5	206304	Bolt, Hex Head 1/2-13 x 6 5/16	54	2	204859	Cover, Pin Slide
21	6	904808	Elevator Tube, Black	55	1	204850	Pin, Locking
22	2	203470	Washer, Flat, Slam Jam	56	4	204290	Net
23	2	900846	Board Bracket, Black	57	1	204853	Lanyard, Black
24	5	206360	Bolt, Hex Head 3/8-16 x 2 5/8	58	4	900235	Rim
25	2	203103	Carriage Bolt	59	6	201683	Spacer, 1.5" Long
26	1	204803	Screw Phillips Head	60	1	203084	Bolt, Carriage, 5/16-18 x 1.75"
27	5	206244	Bolt, Hex Head 1/2-13 x 8" Long	61	1	902319	Rim Bracket
28	1	201159	Ratchet	62	3	201344	Plastic Knob
29	2	904820	Elevator Tube, Black, Long	63	2	203231	Bolt, Carriage, 5/16-18 x 3.5" Long
30	4	203232	Washer, Flat	64	1	203493	Lockut,Hex,1/4-20
31	1	206305	PIN,CLEVIS	65	4	201611	Nut, Hex-Flange 5/16 x 3" Long
32	1	901097	Extension Arm	66	1	207103	Pole Cap, 3-1/2"
33	12	203309	Washer 1" O.D.	67	2	201682	Spacer, Plastic, 1.88" Long
34	4	200516	Cover, Bolt End				

## HARDWARE IDENTIFIER (NUTS & SCREWS)

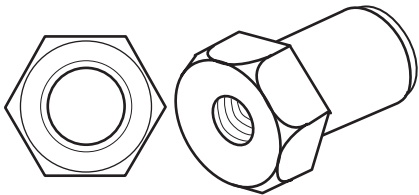

**Item #35 (2)**

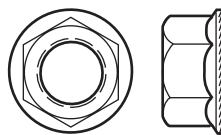

**Item #8 (21)**

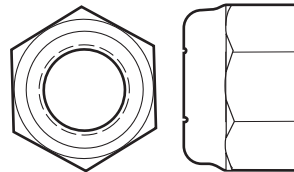

**Item #42 (10)**

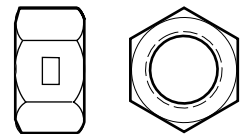

**Item #17 (5)**

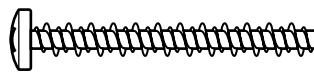

**Item #26 (1)**

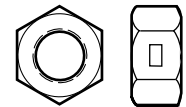

**Item #64 (1)**

## HARDWARE IDENTIFIER (STEEL SPACERS)



**Item #15 (2)**



**Item #38 (2)**

## HARDWARE IDENTIFIER (BOLTS & SCREWS)

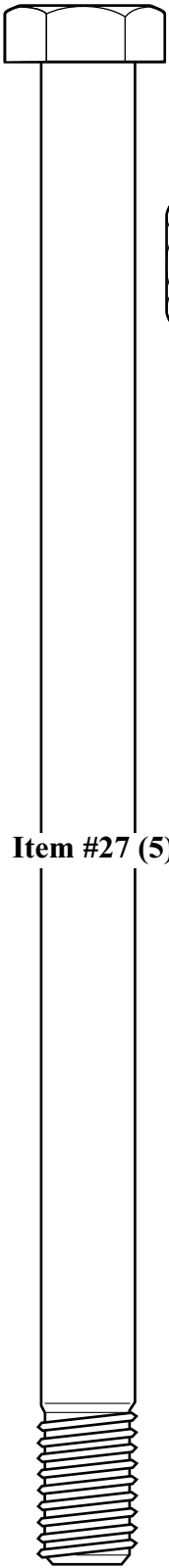

Item #27 (5)

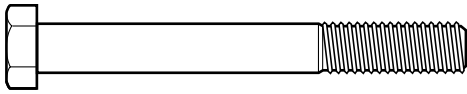

Item #18 (1)

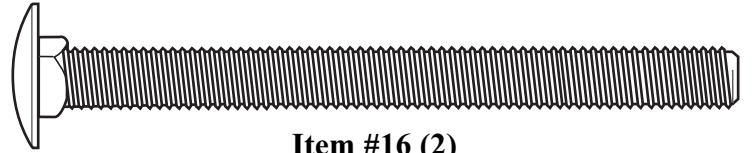

Item #16 (2)

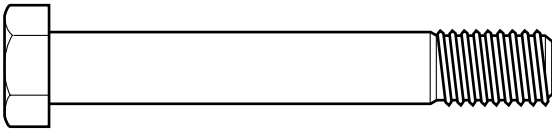

Item #24 (5)

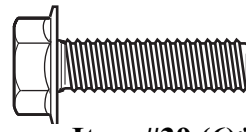

Item #39 (6)\*

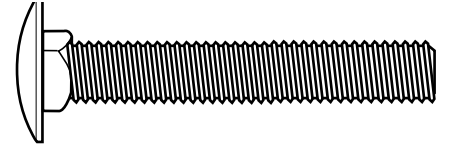

Item #25 (2)

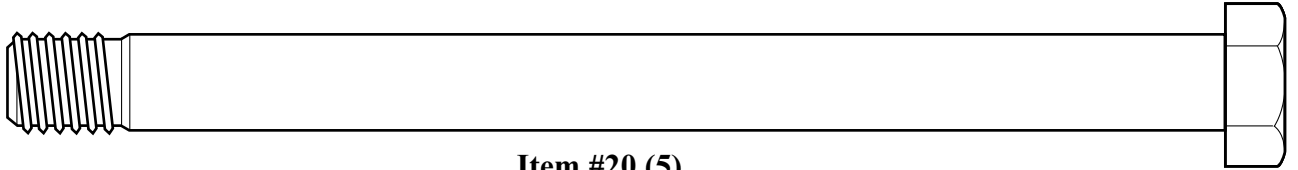

Item #20 (5)

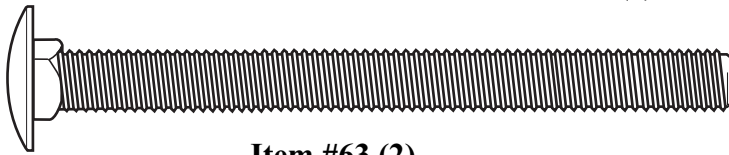

Item #63 (2)

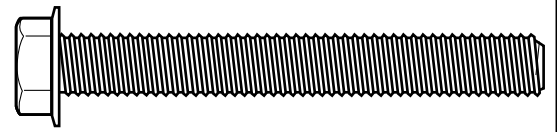

Item #7 (10)

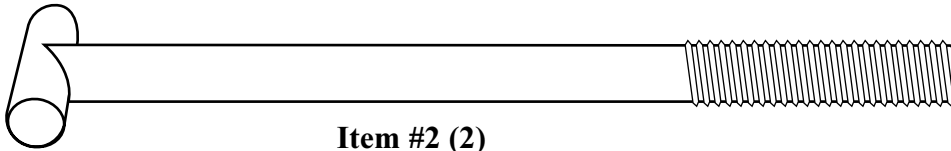

Item #2 (2)



Item #65 (4)

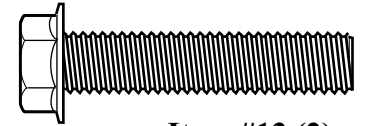

Item #13 (2)

## HARDWARE IDENTIFIER (SPRINGS & WASHERS)

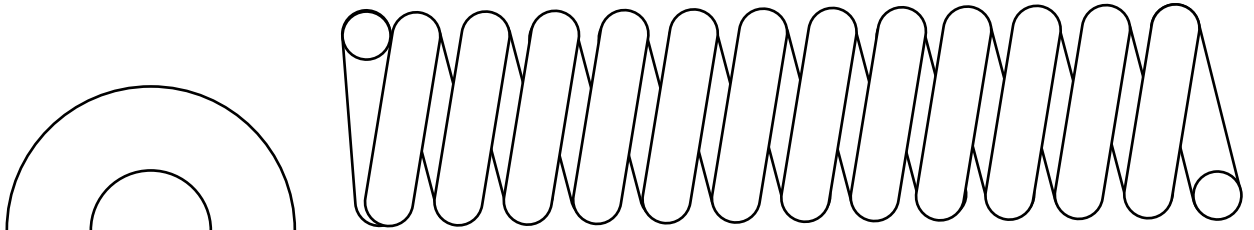

Item #4 (2)

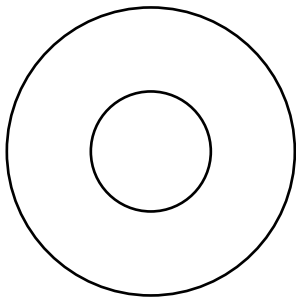

Item #22 (2)

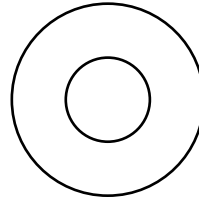

Item #33 (12)

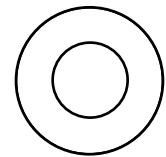

Item #30 (4)

## PLASTIC SPACERS

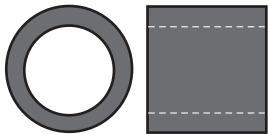

Item #40 (4)



Item #59 (6)



Item #67 (2)

Install display boards in the marked locations. Each mounting location consists of a mounting pole stub with the following dimensions: Height = 8", O.D. = 3 3/8", I.D. = 3 1/8" (arrows indicate direction the board is facing).

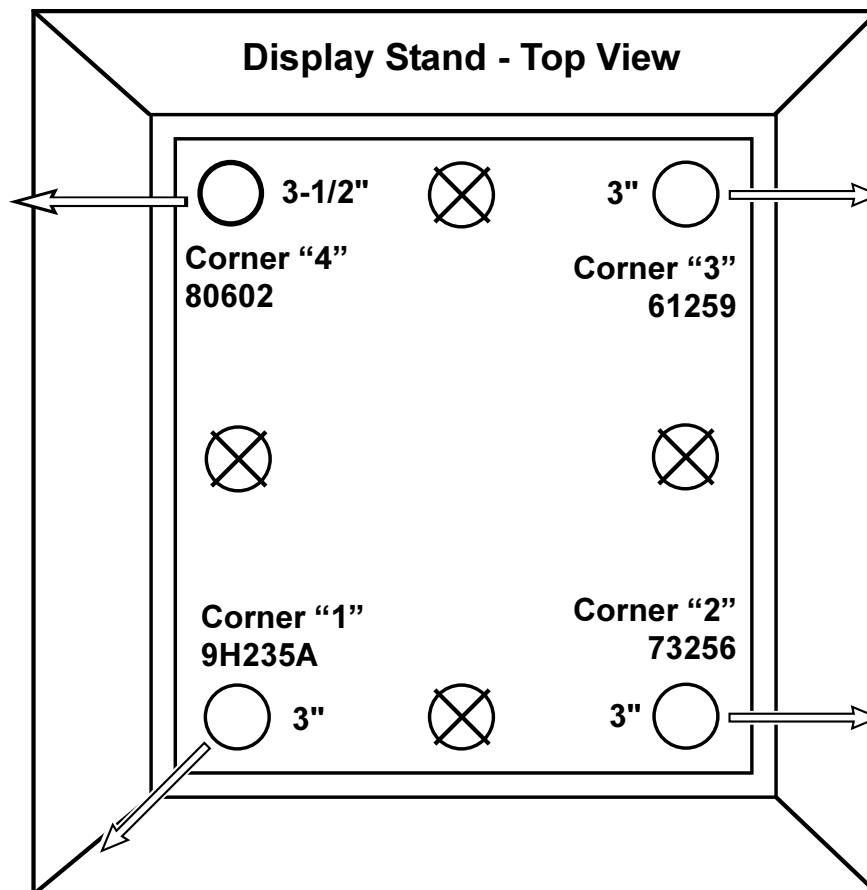

Display boards will be mounted as follows:

**Corner Location 1: 9H235A**

- 48" SFA Board
- Titanium II Logo
- Black Slam Jam Goal with Cover
- Exacta- Height Elevator System (use existing elevator system)

**Corner Location 2: 73256**

- 48" Fan Recycled Board
- Viper Logo
- Black Slam Jam Goal
- Ratchet Elevator System

**Corner Location 3: 61259**

- 44" Fan Recycled Board
- Evolution Logo
- Black Standard Goal
- No Tools, E3 Elevator System

**Corner Location 4: 80602**

- 44" Fan Recycled Board
- Zone Attack Logo
- Black Standard Goal
- Extension Arm (use existing extension arm assembly)

- 1.** At corner locations 1, 2, and 3 install the display pole to the mounting pole stub. If required, secure the display pole by sliding the display wedge (12) into position as shown. To lock the display pole in place, tighten the set screw (13 or 39).

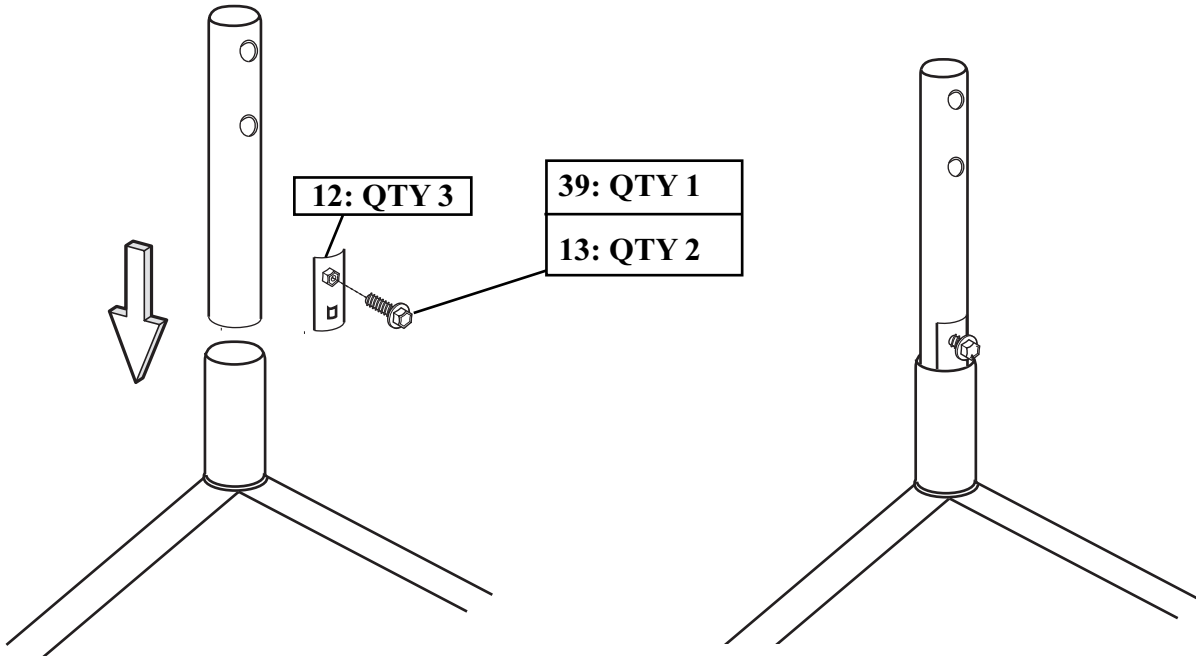

- 2.** At corner location 4 slide the display pole (14) (3 1/2" diameter) over the mounting pole stubs.

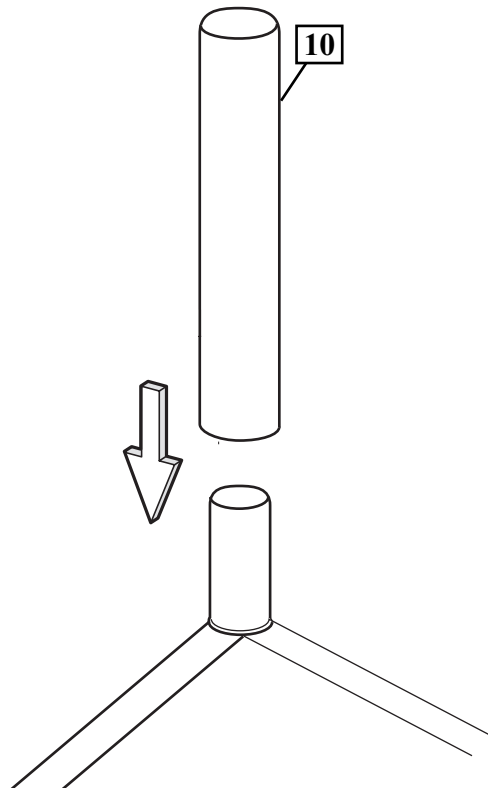

## ELEVATOR ASSEMBLY - Corner Location 1

- 1.** Install pole mount bracket (49) with carriage bolts (16) as shown. Tighten flange nuts (8) completely.

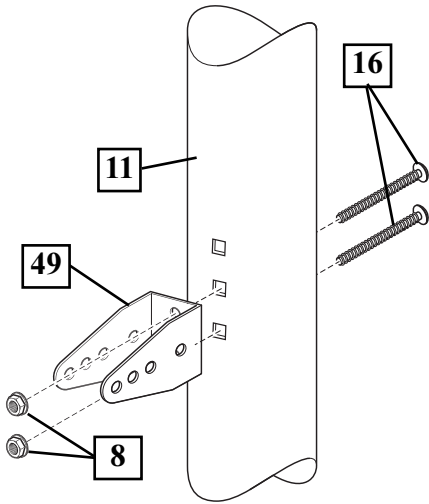

- 2.** Attach spacers (51, 52) to pole mount bracket (49) with bolts (24), washers (30), and nuts (17) as shown. **IMPORTANT! Tighten until washers (30) no longer move.**

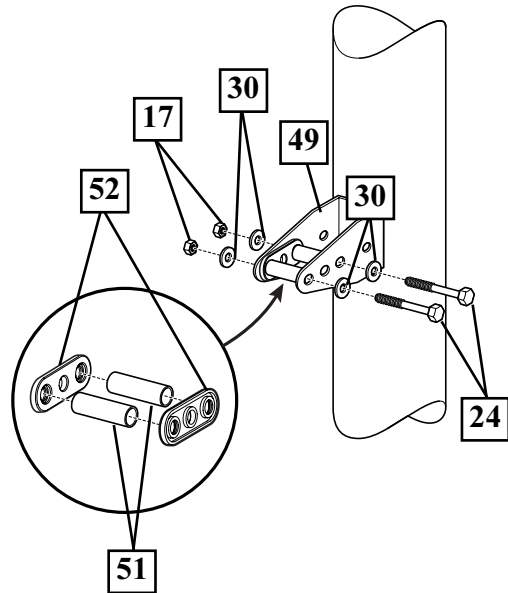

- 3.** Attach covers (54) onto pole mount bracket (49) with carriage bolt (44) and nut (8) as shown. **IMPORTANT! Loop end of pin lanyard (57) over carriage bolt (44) during this assembly. NOTE: Assemble lanyard (57) to locking pin (55) as shown.**

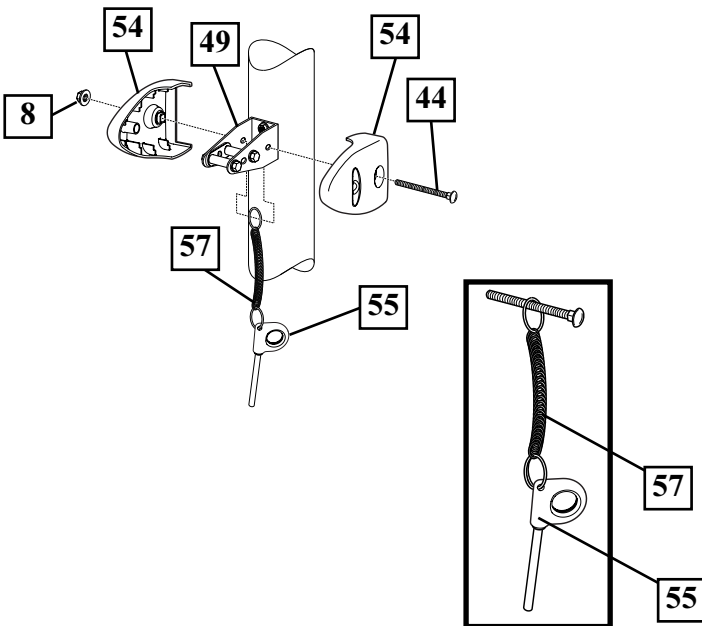

- 4.** Apply logo and height indicator labels (48) to adjustment rod (47) as shown. Attach handle parts (45, 46) to adjustment rod (47) with screw (26), carriage bolts (25), and flange nuts (8) as shown. **NOTE: Holes in adjustment rod allow for either rear access or side access.**

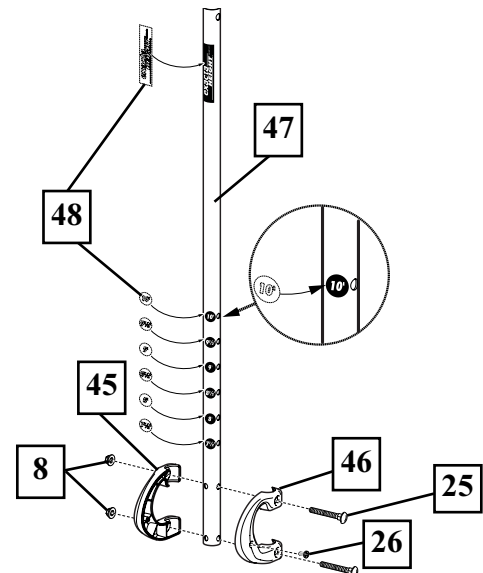



# STEEL FRAME ACRYLIC BACKBOARD ASSEMBLY - Corner Location 1

5.

Attach backboard support brackets (37) to the backboard frame using bolts (24), spacers (38), and nuts (17) as shown.

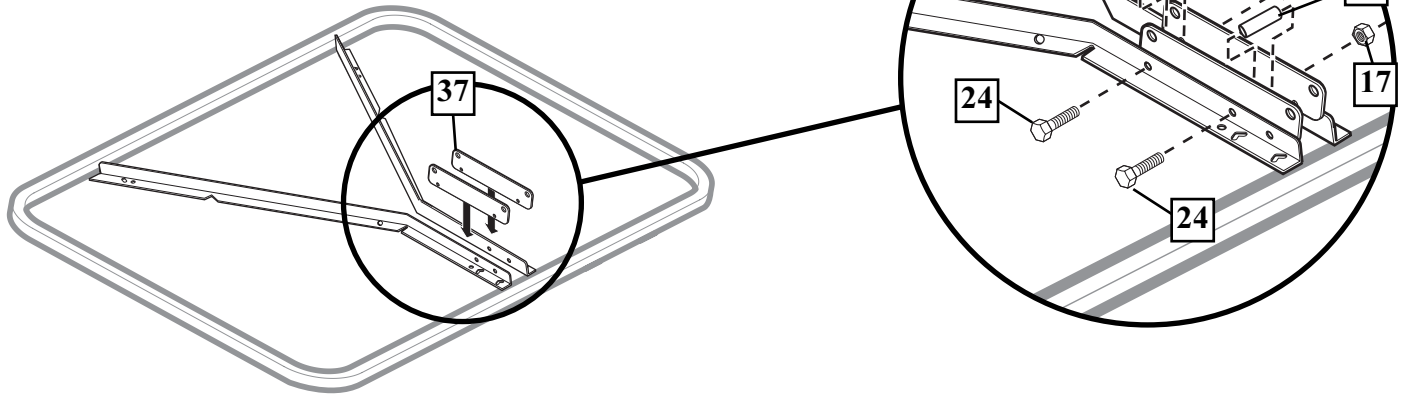

6.

Attach lower elevator tubes (29) to backboard support brackets (37) using spacers (59), bolt (27), and nut (42) as shown. **NOTE:** Rim mounting nuts (8) and bolts (39) supplied with rim hardware.

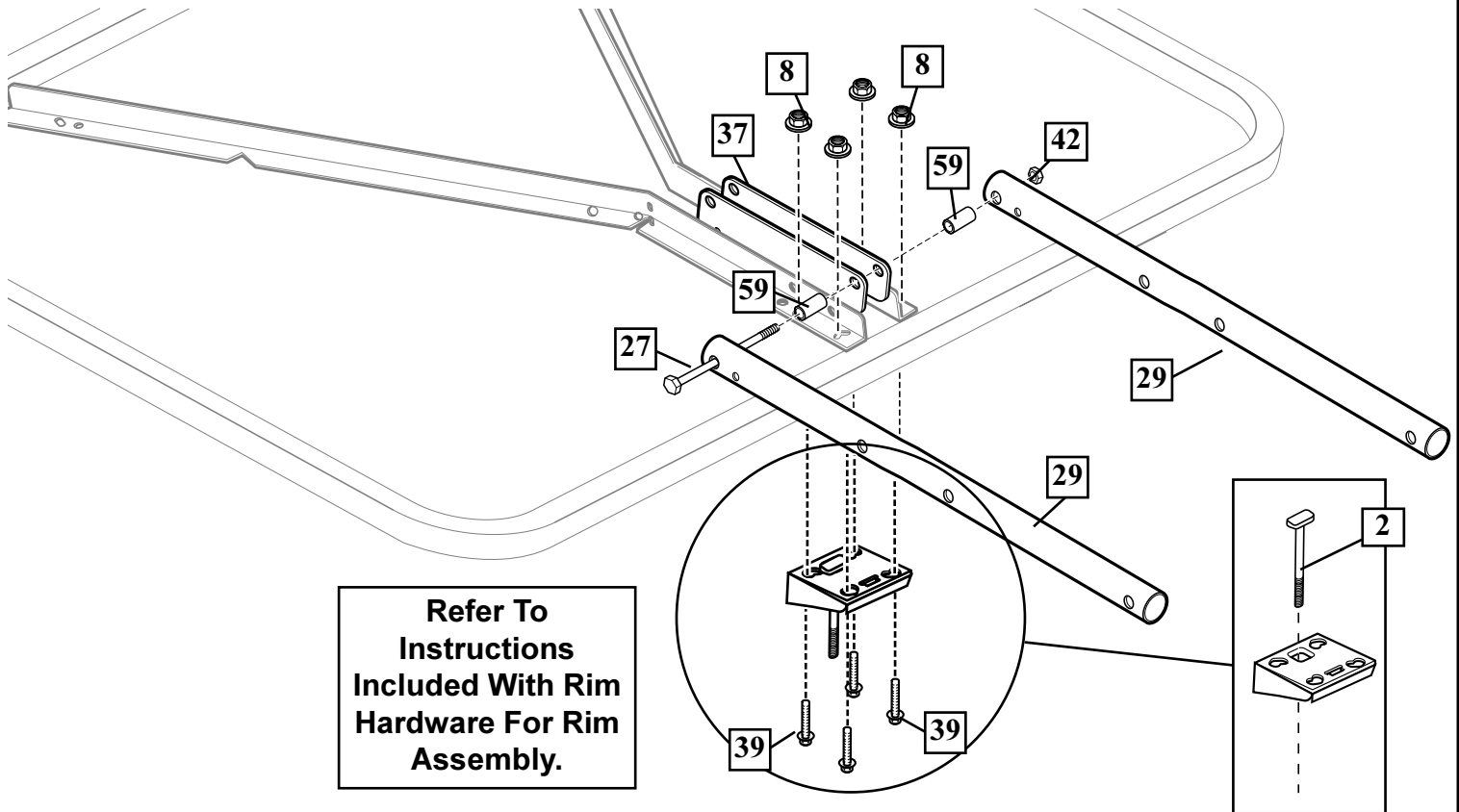

- 7.** Attach upper elevator tubes (21) to backboard support brackets (37) using spacers (59), bolt (27), and nut (42) as shown.

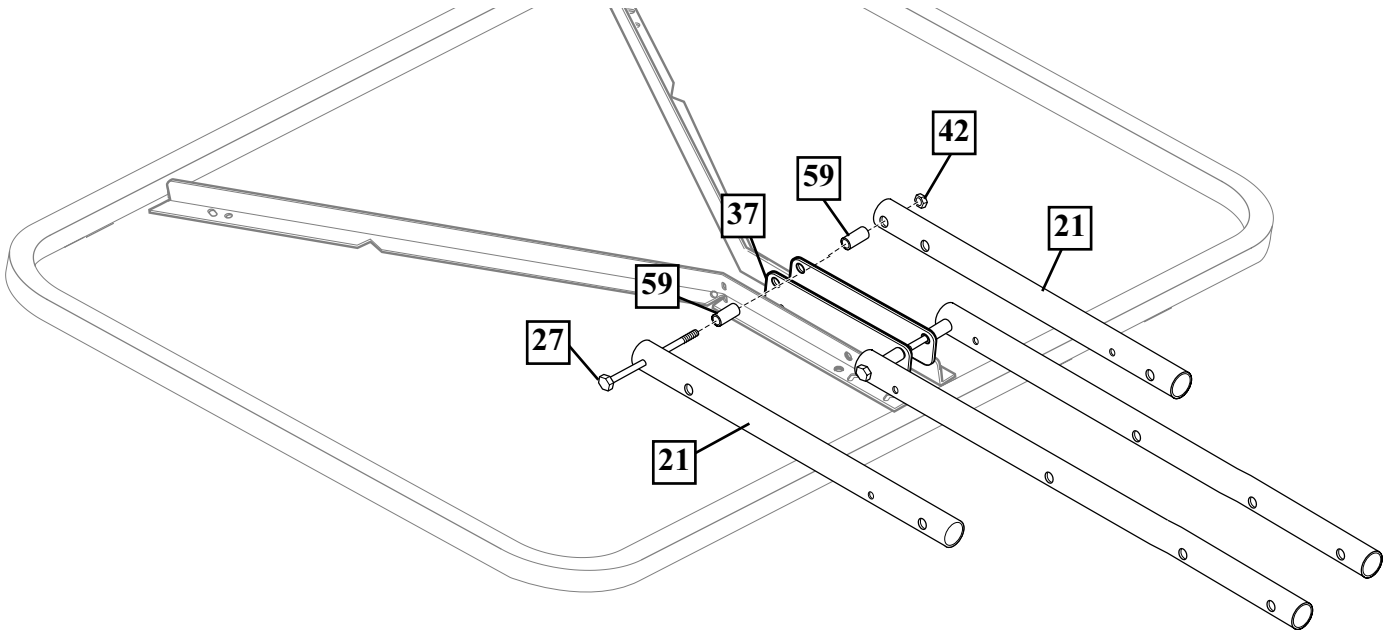

- 8.** Attach backboard assembly to pole section (11). Install pole cap (43).

	<b>! WARNING!</b>
	USE CAUTION; ELEVATOR ASSEMBLY IS HEAVY.  TWO PEOPLE REQUIRED FOR THIS PROCEDURE. FAILURE TO FOLLOW THIS WARNING COULD RESULT IN SERIOUS INJURY AND/OR PROPERTY DAMAGE.

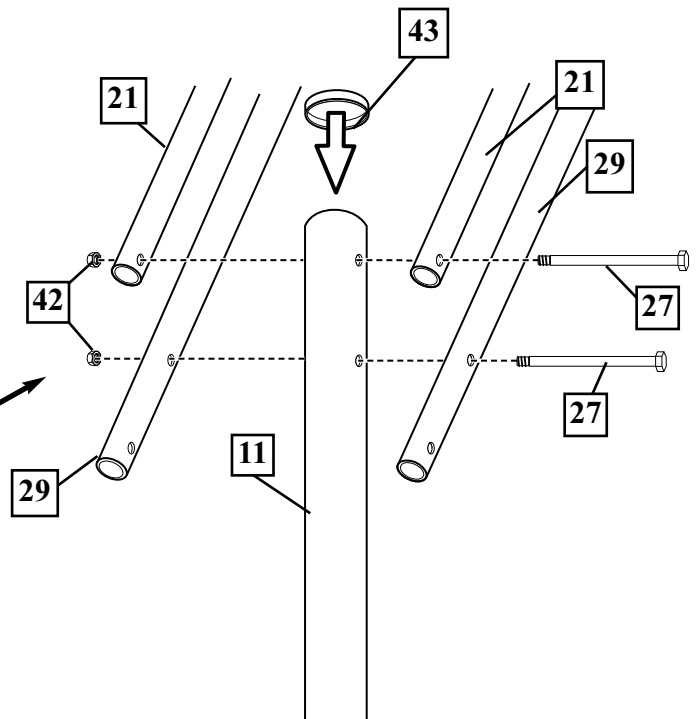
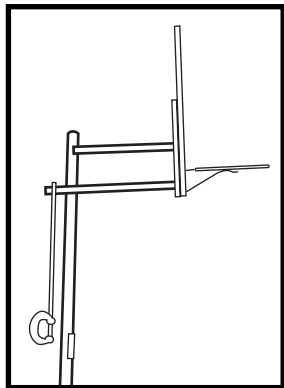

- 9.** Insert handle assembly through pole mount assembly as shown. Lock pole assembly in place at the 10' (3.05m) mark with pin (55).

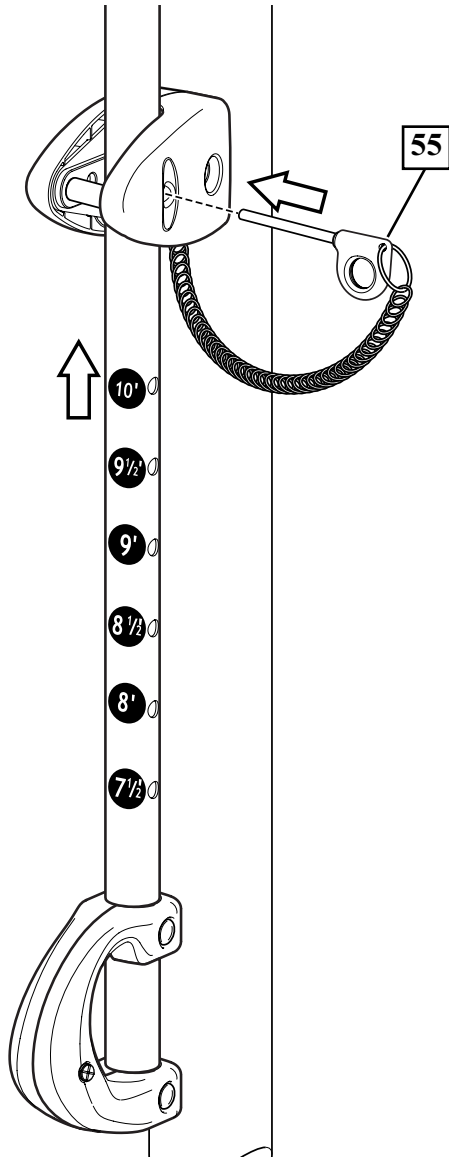

- 10.** Attach adjustment rod (47) to lower elevator tubes (29) using bolt (27) spacer (59) and nut (42) as shown.

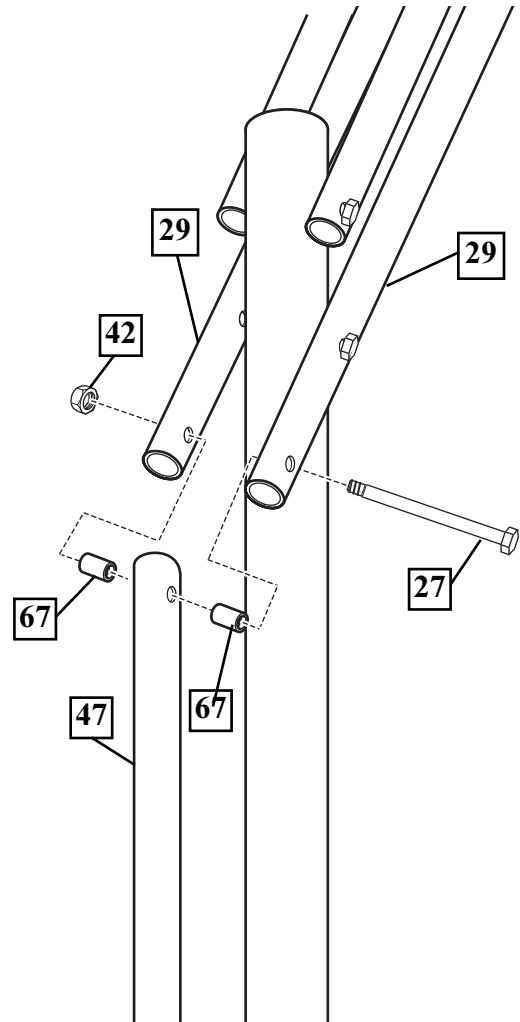

# 12.

- Fit rim (58) securely into bracket (1) as shown.
- Install reinforcement bracket (3) onto "T" bolt (2) as shown.
- Install spring (4) onto "T" bolt (2) as shown.
- Install special nut (35) and washer (22) onto "T" bolt (2).

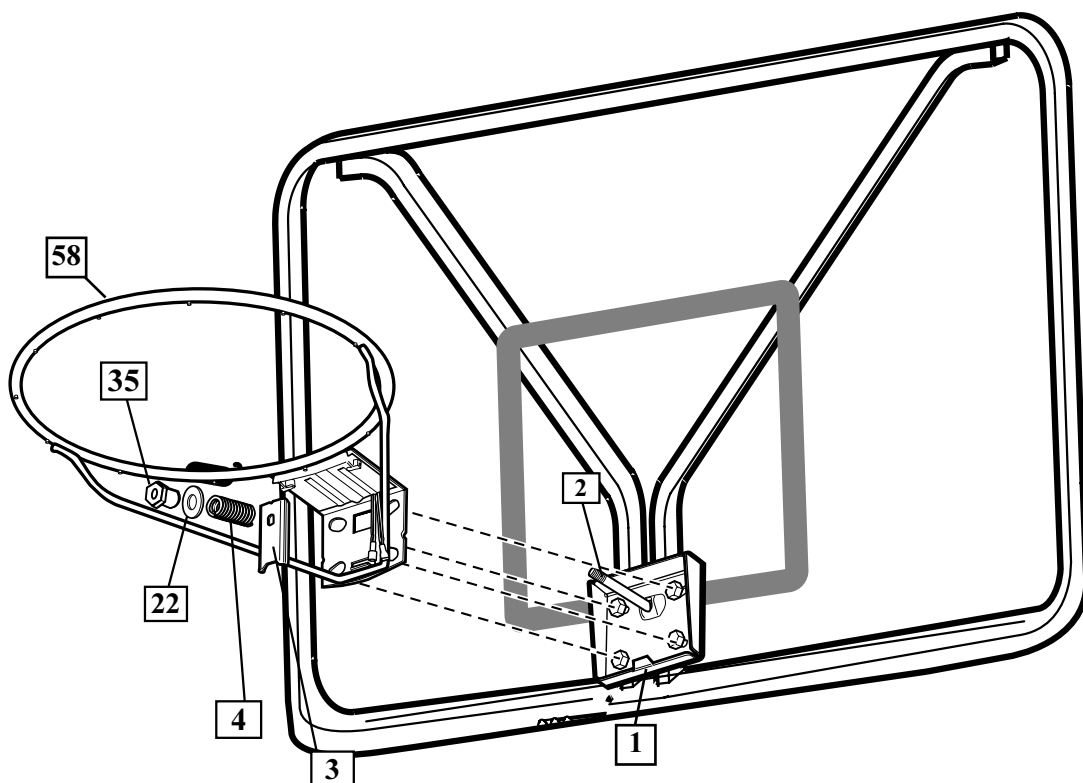

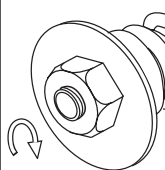
	<p><b>NOTE:</b></p> <p>Tighten nut (35) until flush with end of "T" bolt (2) as shown here.</p>
--	---

# 44" FAN MOLDED PLASTIC BOARD ASSEMBLY - Corner Location 2

- 1.** Correctly identify each pole section.  
**ONLY THE TOP POLE SECTION (14) IS USED IN THIS ASSEMBLY.**

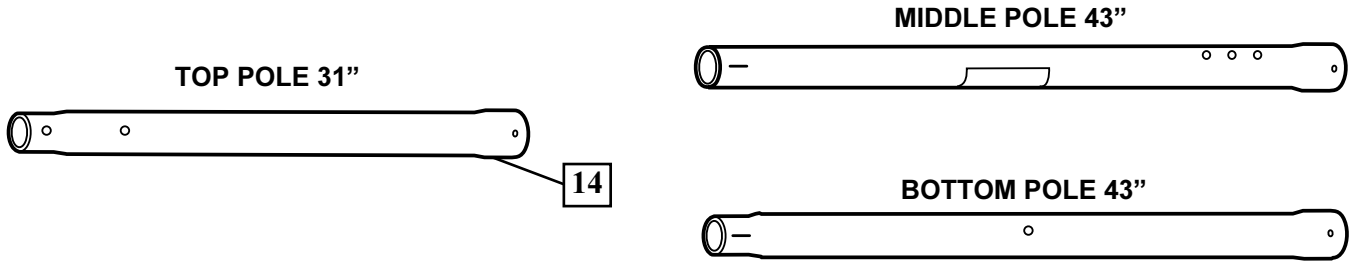

- 2.** Fit spacer (15) into pawl (19). Then continue to assemble as shown. Tighten completely.

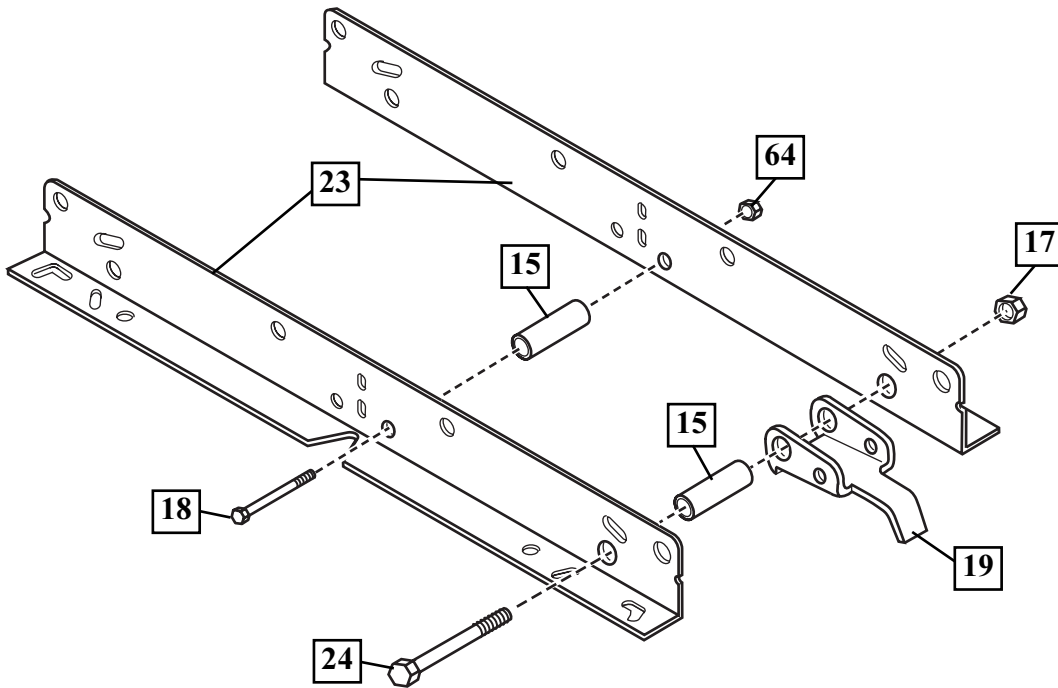

- 3.** Identify elevator tubes (21).

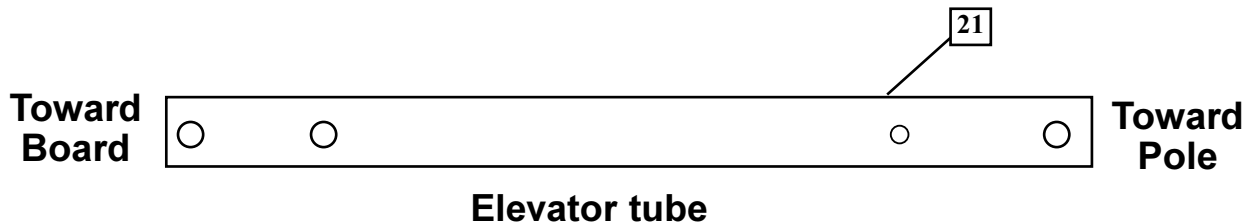

- 4.** Assemble elevator tubes (21) to ratchet (28) and backboard brackets (23) using bolts (20), spacers (5, & 40), and nuts (42) as shown. Tighten completely.

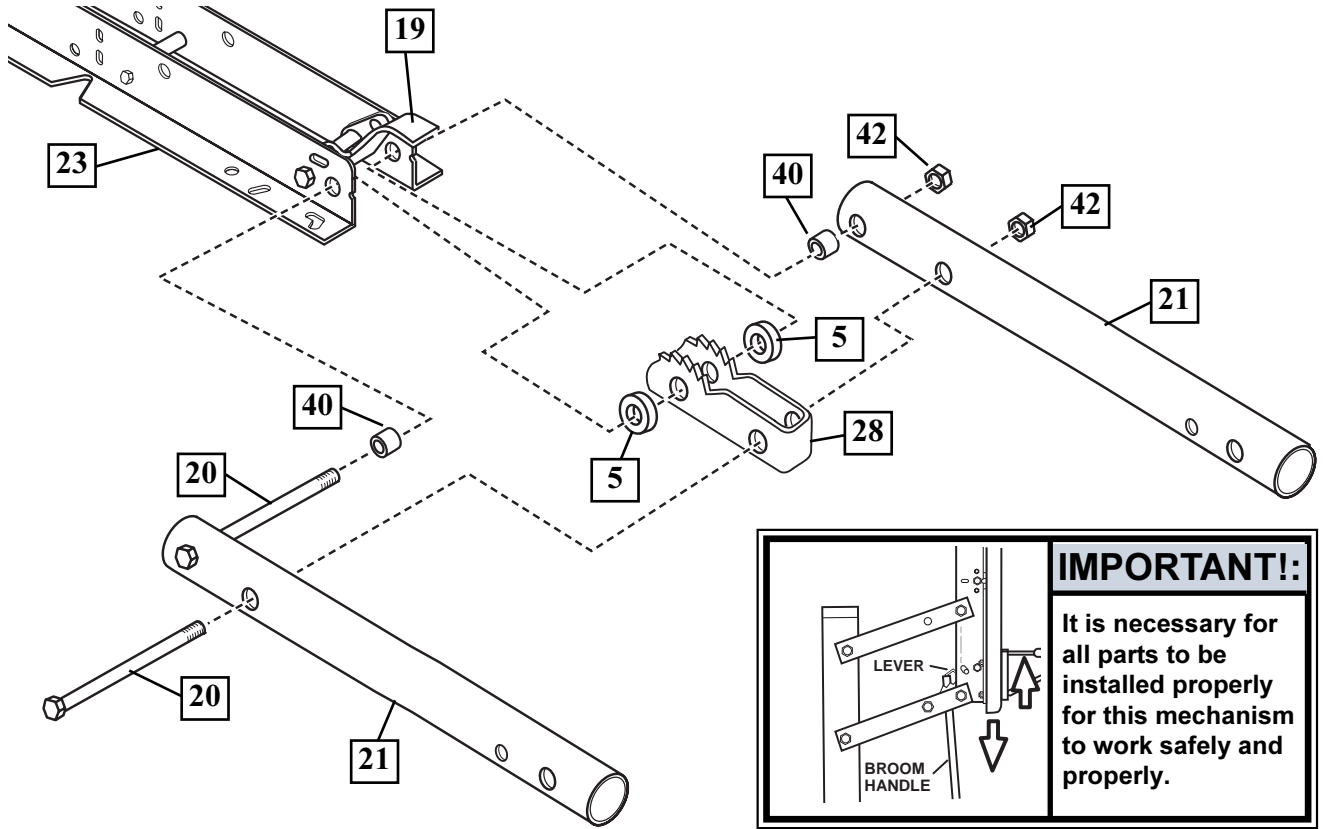

- 5.** Secure pawl (19) in place with clevis pin (31) and washers (6) as shown.

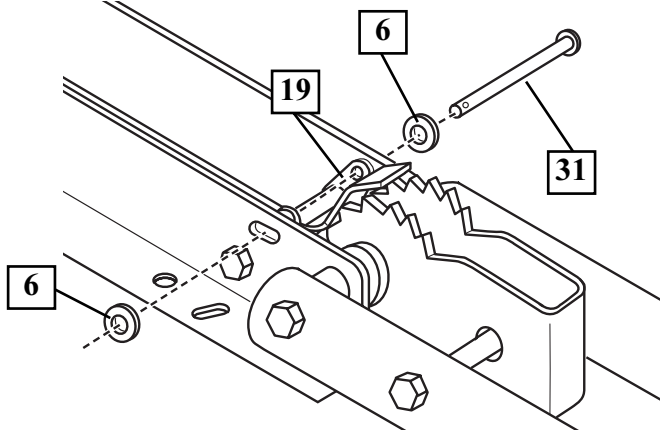

- 6.** Hook one end of the spring (36) into hole of clevis pin (31). Stretch spring (36) and hook it into the [notch of the bracket](#) with pliers.

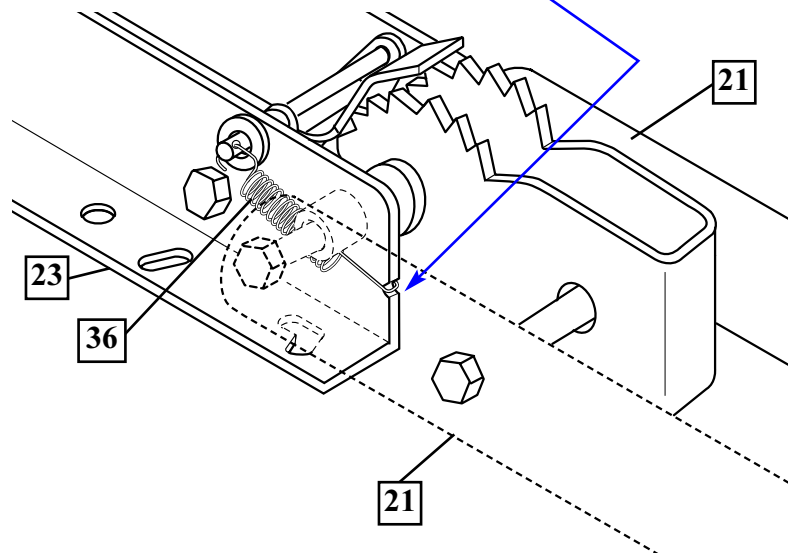

- 7.** Insert "T" bolt (2) through Slam Jam bracket (1) as shown. Secure Slam Jam bracket (1) and backboard bracket (23) assemblies to backboard. Bend upper halves of backboard brackets (23) to line up with holes in backboard and secure with bolts (44 & 7) and nuts (8).

Tighten completely.

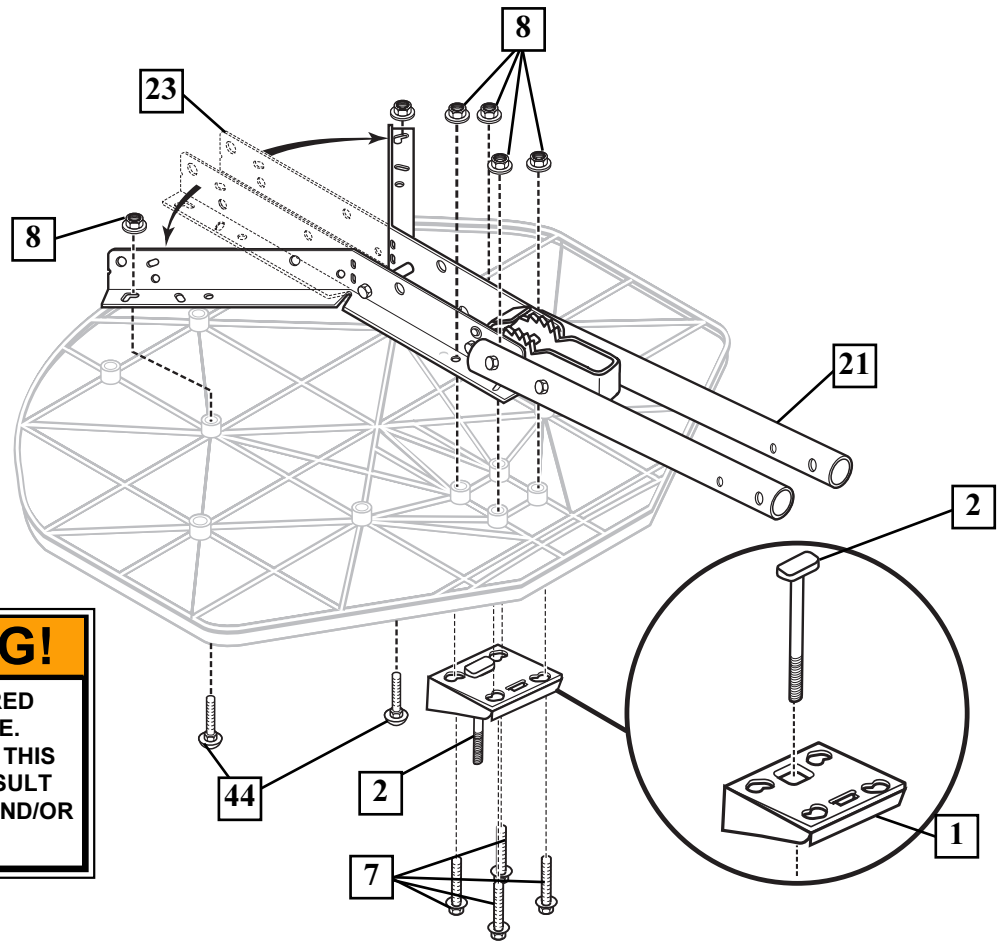

	<b>WARNING!</b>
	TWO PEOPLE REQUIRED FOR THIS PROCEDURE. FAILURE TO FOLLOW THIS WARNING COULD RESULT IN SERIOUS INJURY AND/OR PROPERTY DAMAGE.

- 8.** Attach upper elevator tubes (21) to backboard brackets (23) using spacers (40) bolt (20) and nut (42) as shown.

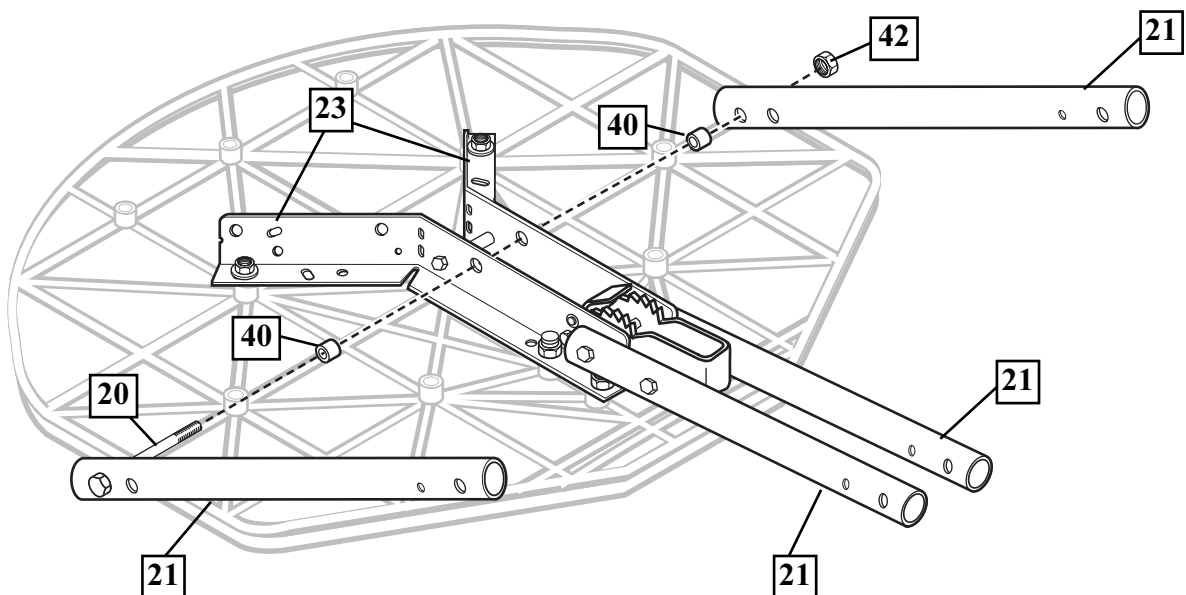

**9.** Attach upper and lower elevator tubes (21) to top pole section (14) using bolts (20) and nuts (42) as shown. Attach pole cap (41) as shown.

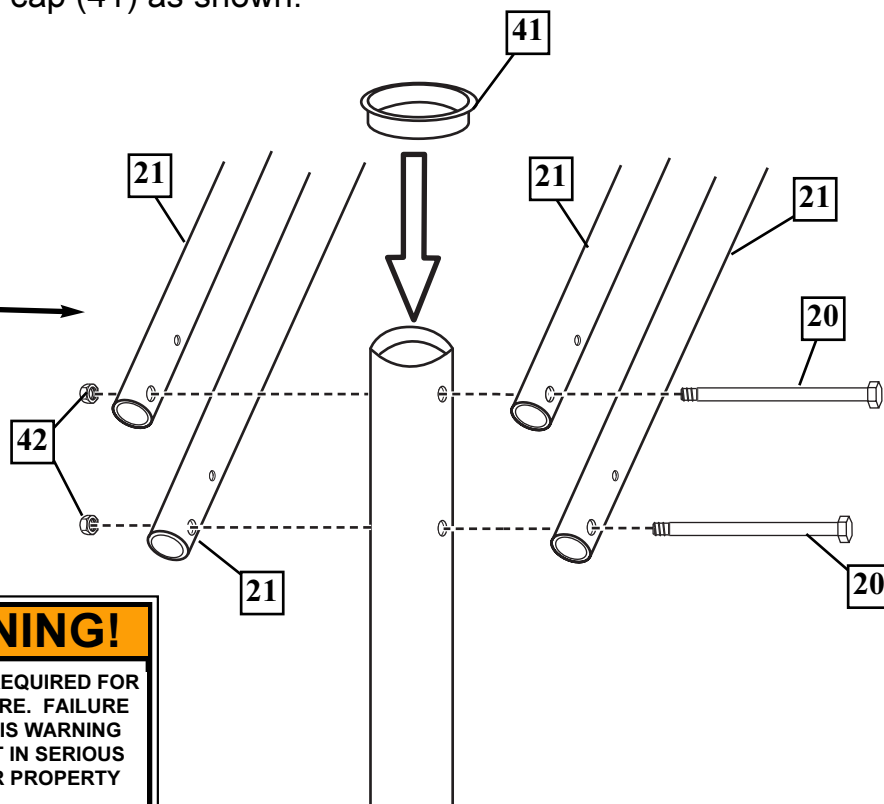
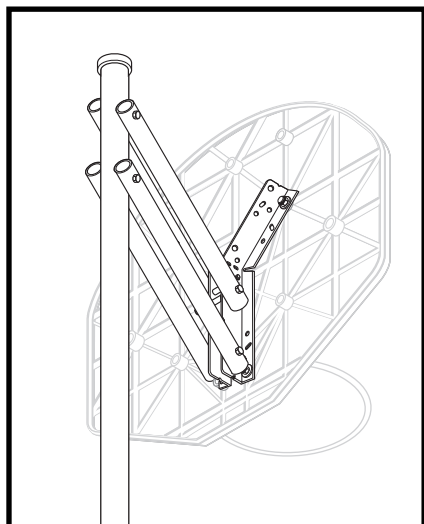

	<b>WARNING!</b> TWO PEOPLE REQUIRED FOR THIS PROCEDURE. FAILURE TO FOLLOW THIS WARNING COULD RESULT IN SERIOUS INJURY AND/OR PROPERTY DAMAGE.
--	--

**10.**

- Fit rim (58) securely into bracket (1) as shown.
- Install reinforcement bracket (3) onto "T" bolt (2) as shown.
- Install spring (4) onto "T" bolt (2) as shown.
- Install special nut (35) and washer (22) onto "T" bolt (2).

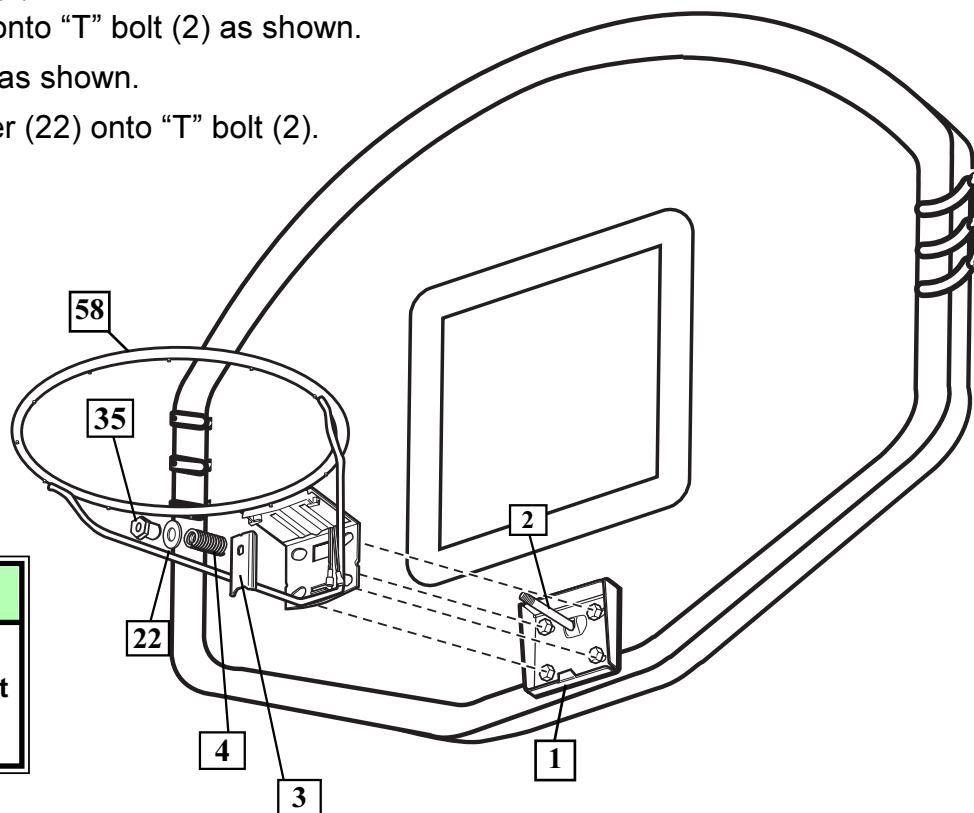

	<b>NOTE:</b> Tighten nut (35) until flush with end of "T" bolt (2) as shown here.
--	--



# FAN MOLDED PLASTIC BOARD ASSEMBLY - Corner Location 3.

**1.** Correctly identify each pole section. Poles have an identification sticker that will be used as a reference point in the next step.

**ONLY THE TOP POLE SECTION (50) IS USED IN THIS ASSEMBLY.**

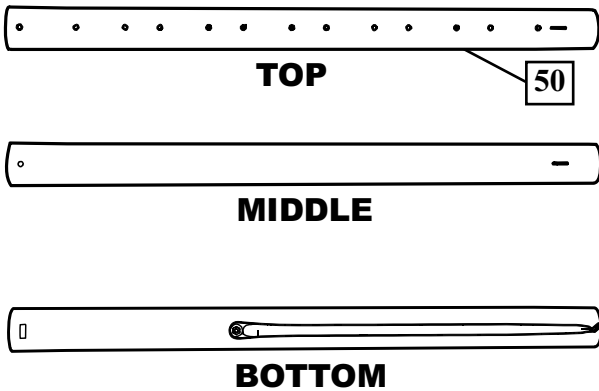

**2.** Pole bracket will need to be lightly pressed into backboard ribbing. Be sure to press completely into place. Attach rim (58) to backboard and pole bracket (53) with knob (62), reinforcement bracket (61), and carriage bolt (60) as shown. Tighten knob completely.

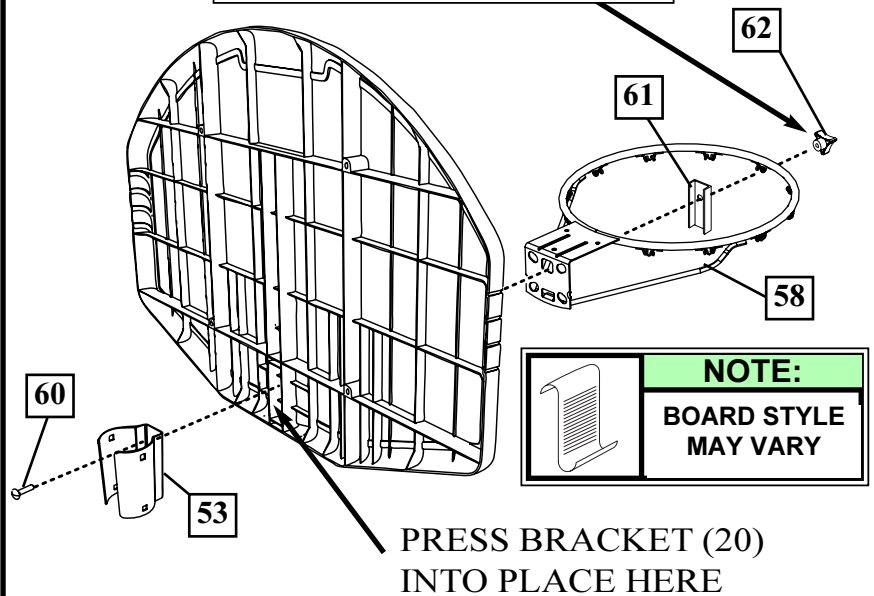

**3.** Attach board assembly to pole with carriage bolts (63) and knobs (62) as shown. Install pole cap (41) as shown.

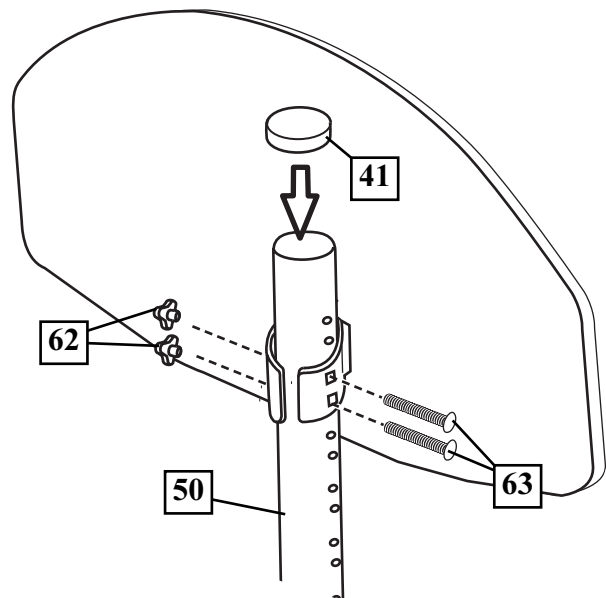

# FAN BACKBOARD ASSEMBLY - Corner Location 4.

**1.** Assemble fan backboard as shown below with a standard rim as shown.

## **⚠ WARNING**

**TWO PERSON MINIMUM  
REQUIRED FOR THIS  
PROCEDURE.  
NOT FOLLOWING  
RECOMMENDATION MAY  
RESULT IN BODILY INJURY.**

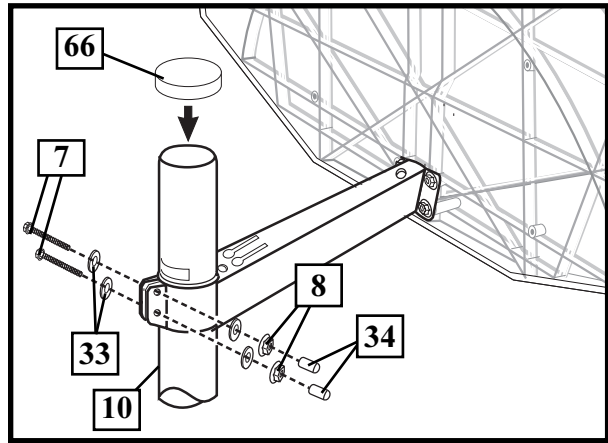
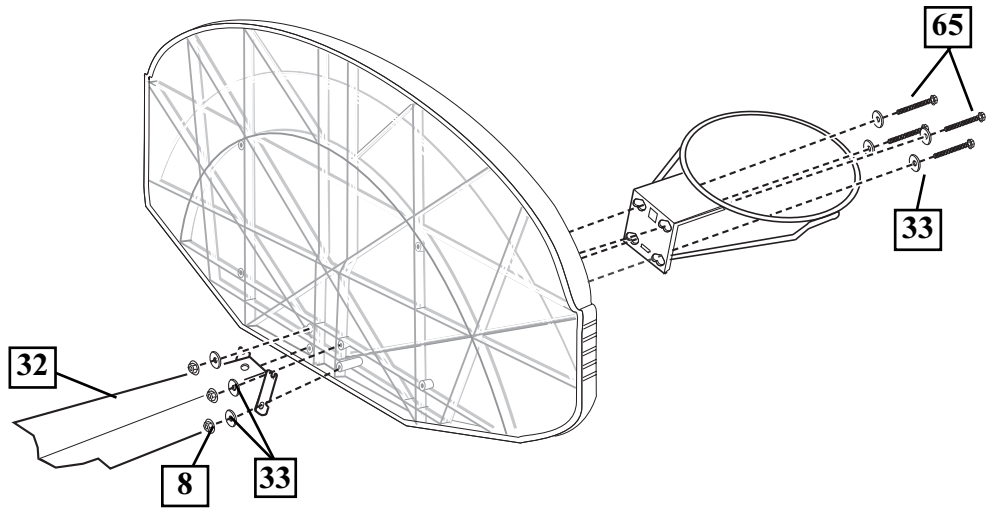

**11.** Install net clips.

	<p><b>! WARNING!</b></p> <p>USE OF THIS PRODUCT WITHOUT PROPER INSTALLATION OF SMART CLIPS®, OR WHEN ALL SMART CLIPS® ARE NOT PRESENT COULD RESULT IN BODILY HARM. BE SURE TO FOLLOW DIRECTIONS CAREFULLY.</p>
--	--

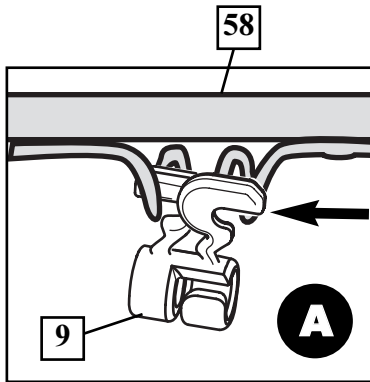
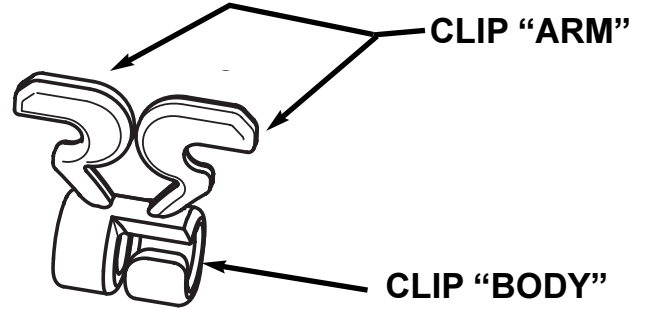

Insert one "arm" of clip into ram as shown. Twist "body" of clip slightly so that second "arm" slides over the top of the first "arm" as shown.  
Push in direction indicated by arrows.

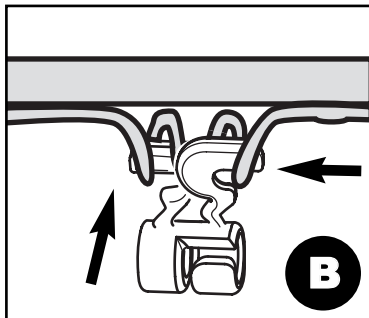

Push second "arm" back and into ram as shown.

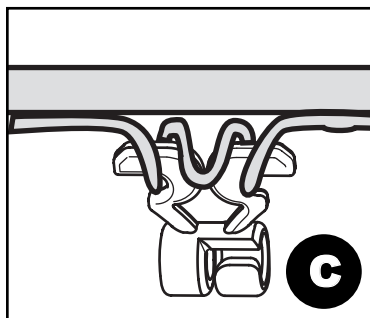

Twist "body" of clip slightly again to spread "arms" of clip. Clip "arms" must be flat and touching edge to edge as shown, not overlapping.

**12.** Install net.

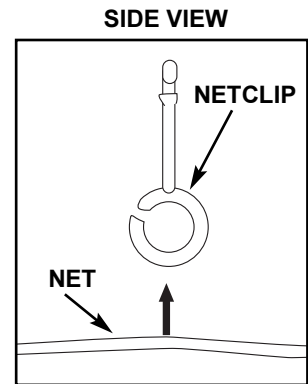
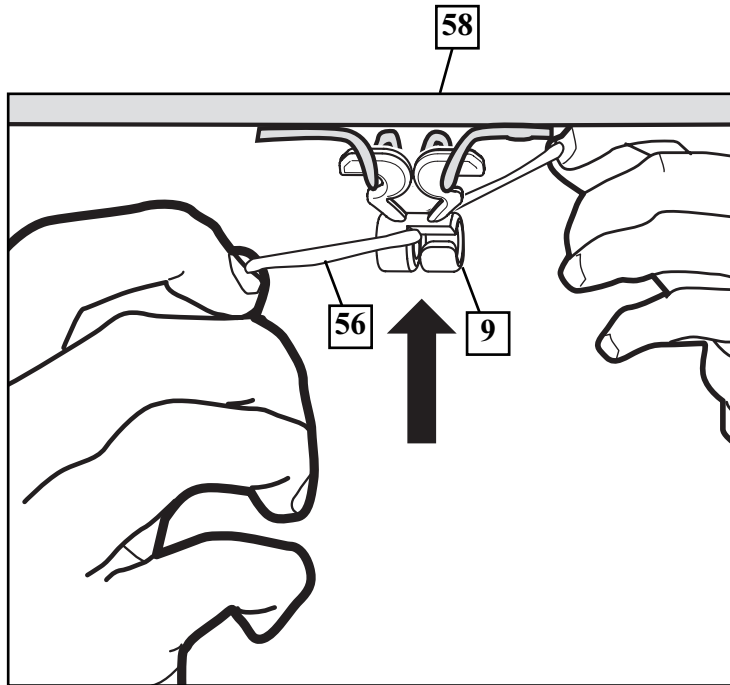

Insert net into bottom of clip as shown.

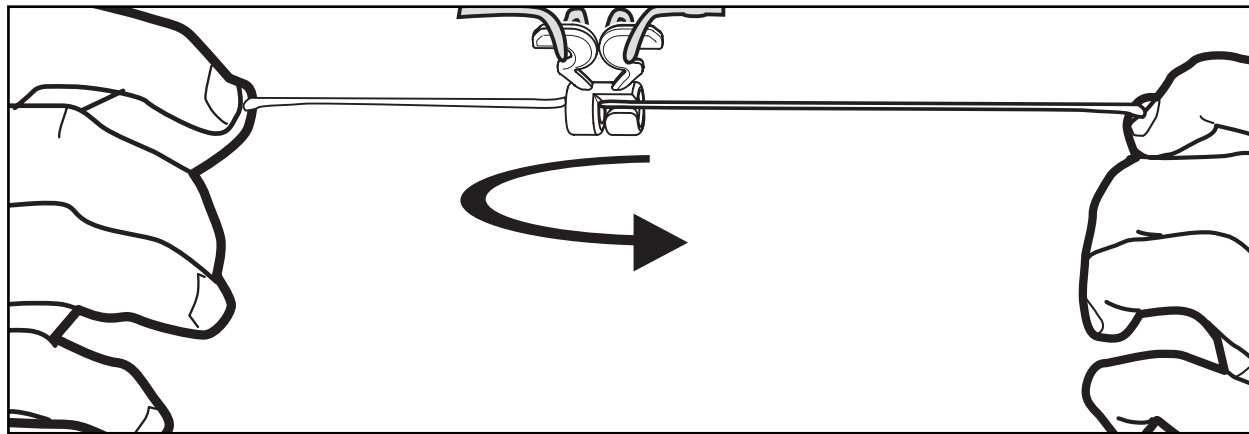

Twist net until it snaps into position.  
Net must be centered through clip.

