

verilux[®]
The Healthy Lighting Company™

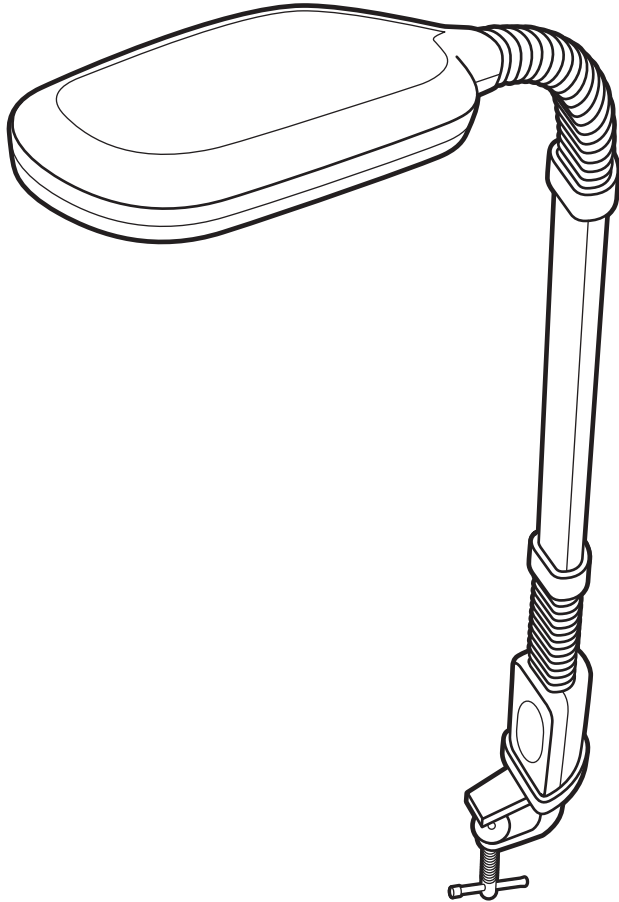

Original | Deluxe

Natural Spectrum® Clamp Lamp

VC01



Dear Customer,

Thank you for purchasing the Verilux® Original Natural Spectrum® Deluxe Clamp Lamp. You have received an innovative and quality manufactured product, backed by a three-year limited warranty. As a Verilux® customer, your satisfaction means everything to us. We look forward to serving you now and in the future.

Many other healthy lighting products are available through our catalog and online. To request a free copy of our catalog, call our toll-free number 1-888-544-4865. You may also visit us on the web at www.Verilux.com to learn more about all our quality Verilux® products.

Have a Bright Day!

A handwritten signature in black ink that reads "Nicholas Harmon". The signature is written in a cursive, flowing style.

Nicholas Harmon
President and CEO

IMPORTANT SAFETY INSTRUCTIONS

CAUTION:

- TO REDUCE THE RISK OF ELECTRIC SHOCK, DO NOT DISMANTLE. THERE ARE NO SERVICEABLE PARTS INSIDE.
- TO REDUCE THE RISK OF FIRE OR ELECTRIC SHOCK, DO NOT EXPOSE THIS UNIT TO RAIN OR MOISTURE.

WARNING: TO REDUCE THE RISK OF FIRE, ELECTRIC SHOCK OR PERSONAL INJURY:

- Turn off/unplug and allow to cool before replacing bulb or cleaning.
- Light bulbs get HOT quickly! Do not touch the bulb while the lamp is on.
- Do not operate the lamp in close proximity to flammable or combustible vapors, such as aerosol (spray) products or where oxygen is being administered.
- Use only the type of bulb and maximum wattage indicated by the manufacturer.
- Never cover the lamp when it is in operation.
- **Read these instructions** – before using this lamp.
- **Keep these instructions** – for future reference.
- Do not use this lamp in damp/humid or wet locations.
- For indoor use only.
- Clean only with dry cloth.
- Do not defeat the safety purpose of the polarized plug. A polarized plug has two blades with one wider than the other. If the provided plug does not fit in your outlet, consult an electrician for replacement of the obsolete outlet.
- Protect the power cord from being walked on or pinched particularly at plugs, convenience receptacles, and the point where it exits from the lamp.
- Unplug this lamp during lightning storms or when unused for long periods of time.
- If the lamp has been damaged in any way, such as power-supply cord or plug is damaged, liquid has been spilled or objects have fallen onto the lamp, the lamp has been exposed to rain or moisture, does not operate normally, or has been dropped, it should not be operated. There are no user serviceable parts within this lamp.

SAVE THESE INSTRUCTIONS

ASSEMBLY & SET-UP

Main Parts & Controls

- A. Lamp Head
- B. Clamp Assembly
- C. Metal Clamp Swivel
- D. Lamp Tightening Knob
- E. Power Cord
- F. Polarized Plug
- G. Parabolic Grid Diffuser
- H. Bulb
- I. High/Off/Low Switch

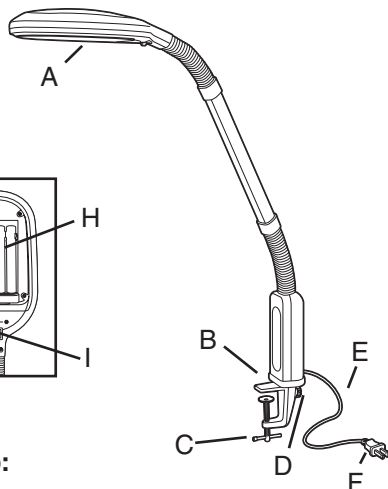
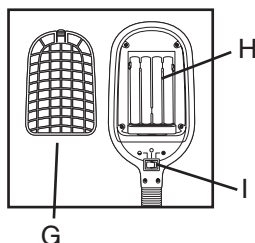

Read Instructions Carefully Before Set-up:

1. Remove lamp and packaging from box. **Note:** Please save original packaging for repacking should you need to return the product.
2. Remove clamp and turn the clamp screw counterclockwise until it is open slightly wider than the work surface to which you are attaching it. Clamp fits flat surfaces up to 2.25" thick. Surface must be a minimum of 1.5" deep for clamp to hold securely.
3. Slide the clamp onto work surface, and turn metal clamp swivel clockwise to tighten securely.
4. Place lamp shaft into clamp assembly and turn tightening knob (D) clockwise to secure.
5. Adjust upper and lower goosenecks as needed to illuminate work surface.

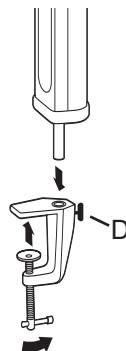

6. Attaching the Parabolic Grid Diffuser
 - Remove grid diffuser from protective plastic bag and remove all styrofoam packing around bulb.
 - Bulb may have loosened in socket during transit, please press down to ensure it is fully seated.
 - Insert plastic pegs at bottom of grid diffuser into openings near bulb socket
 - Snap tab into place

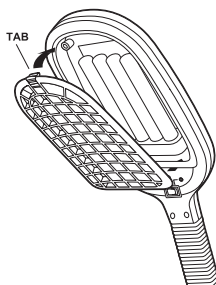

7. Plug lamp into outlet and turn on; if bulb does not illuminate instantly, please refer to the troubleshooting section of this manual.

ASSEMBLY & SET-UP cont.

Moving the Clamp Lamp to a New Location:

1. Unplug lamp from power source.
2. Turn the tightening knob counterclockwise 1/4 turn to loosen the lamp shaft and pull lamp out of clamp socket.
3. Move clamp assembly, secure it to surface and replace lamp into clamp socket.
4. Turn tightening knob clockwise to secure and plug lamp into outlet.

BULB REPLACEMENT

Removal

1. Unplug lamp from power source.
2. To access the bulb, remove grid diffuser by depressing the tab and lifting it out. (See page 4)
3. Firmly hold bulb base (B) and pull bulb (C) from the socket (A) in an outward motion.

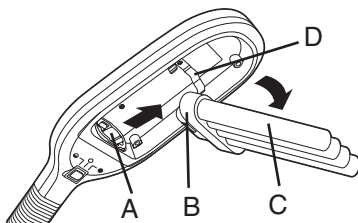

Installation

1. Unplug lamp from power source.
2. Firmly hold base (B) and push bulb (C) into the socket (A).
3. Be sure bulb is firmly seated in the socket (see below) and snapped into the metal bulb clip (D).
4. Replace grid diffuser.

Correctly seated bulb

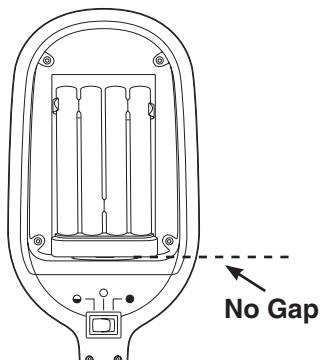

Incorrectly seated bulb

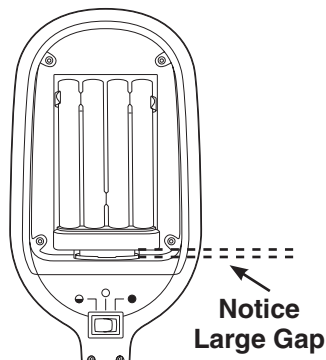

GENERAL PRECAUTIONS

- Do not use with power supply voltage other than 120V AC
- Avoid placing the lamp in areas that are dusty, humid/moist, lack ventilation, or are subject to constant vibration.
- Not for use with light dimmers, timers, motion detectors, voltage transformers, or extension cords.
- Do NOT use lubricating agent in bulb assembly.
- The light bulb may become loose during transit. To reinstall the light bulb, see the bulb installation instructions on page 4.
- Close supervision is recommended when this lamp is used by or near children, or others who may not understand the need for these precautions. Do not leave the lamp unattended during use.

This product may cause interference with radios, cordless telephones, or devices that use a wireless remote control, such as televisions.

This lamp has been tested and found to comply with Part 18 of the FCC Rules. These limits are designed to provide reasonable protection against harmful interference in a residential installation. This lamp generates, uses, and can radiate radio frequency energy and, if not used in accordance with the instructions, may cause harmful interference to radio communications. If interference occurs try to correct the interference by one or more of the following measures:

- Reorient or relocate the receiving antenna.
- Increase the separation between the lamp and receiver.
- Connect the lamp into an outlet on a circuit different from that to which the receiver is connected.
- Move the lamp out of the line of sight of the remote control receiver.
- Consult the dealer or an experienced radio/TV technician for help.

Note: *This product may cause interference to radio equipment and should not be installed near maritime safety communications equipment or other critical navigation or communication equipment operating between 0.45-30 MHz.*

TROUBLESHOOTING

Before requesting service on your Verilux® lamp please read the following:

- Make sure all power connectors, cords, and plugs are inserted fully and securely.
- Make sure there is power to the wall outlet or try another outlet – not connected to a dimmer.

PROBLEM	CHECK	SOLUTION
Light won't come on	Has the plug come loose?	Insert plug securely into wall outlet.
	Is the bulb old?	Check the bulb for blackening/darkening at the ends (an indicator of bulb life) and replace bulb. See www.VeriluxStore.com .
	Is the bulb connected securely to the socket?	Be sure the bulb is securely seated into the socket, repeat the bulb installation process.
Blackening/darkening at ends of bulb	Is the bulb new?	Sometimes when a new bulb is turned on for the first time the ends will darken, but this will fade after a few minutes.
	Is the bulb old?	With older bulbs darkening of the ends indicates end of bulb life. (This doesn't affect operation except to reduce the amount of light available since the phosphor in that area has become inactive). Bulb replacement is recommended.
Light flickers	Has the plug come loose?	Insert plug securely into wall outlet.
	Is the bulb connected securely to the socket?	Be sure the bulb is securely seated into the socket, repeat the bulb installation process.
	Is the lamp connected to a dimmer switch?	Connect lamp plug only to wall outlet without a dimmer switch.

CARE & CLEANING

Your Verilux® lamp is made from high quality materials that will last for many years with a minimum of care.

Clean only with a soft dry cloth – **DO NOT USE SOLVENTS OR CLEANERS CONTAINING ABRASIVES OR AMMONIA**



WARNING: To prevent risk of shock or personal injury when cleaning lamp, make sure you have turned off and unplugged the lamp, and allow sufficient time for the bulb to cool.

Three-Year Limited Warranty

ATTENTION! ONCE OPENED, PLEASE *DO NOT* RETURN THIS PRODUCT TO THE STORE WHERE IT WAS PURCHASED FOR REPAIR OR REPLACEMENT!

Many questions may be answered by visiting www.Verilux.com, or you may call our customer service department at 1-888-544-4865

This limited warranty is provided by:

Verilux, Inc., 340 Mad River Park, Waitsfield, VT 05673

Verilux® warrants this product to be free from defects in material and workmanship for a period of three years from the date of the original retail purchase. During the limited warranty period, Verilux, Inc. will, at its option, repair or replace defective parts of this product, at no charge to the customer, subject to the following limitations. This limited warranty does not include any postage, freight, insurance or delivery fees. This warranty does not cover damage, defect or failure caused by or resulting from accident, external destruction, alteration, modification, abuse, misuse, or misapplication of this product.

If, during the first three years of ownership, this product fails to operate properly, it should be returned as specified below:

Please pack the defective product in its original protective packing and box, with a copy of your sales receipt, along with \$6.95 (check or money order to cover shipping and handling), and send to:

**For U.S. Postal Service Only:
Verilux Warranty**

Service Center, c/o WTB

P.O. Box 119, West Redding, CT 06896

**For Fed Ex & UPS Only:
Verilux Warranty**

Service Center, c/o WTB

32 Henry Street, Bldg 17A, Bethel, CT 06801

Please allow 4-6 weeks before you receive the repaired or replaced product.

ATTENTION: When returning a product, be aware that damage during shipping is the responsibility of the purchaser and will void any warranty claim. We recommend that you insure the shipment by shipper when returning this product or any parts. Be sure to return product in original packaging.

Note: Verilux® recommends using a quality surge suppressor on all electronics equipment. Voltage variations and spikes can damage electronic components in any system. A quality suppressor can eliminate the vast majority of failures attributed to surges and may be purchased at electronics stores.

Due to ongoing improvements, actual product may have slight variations from the product described in this manual.

Please visit our web site at: www.Verilux.com



340 Mad River Park, Waitsfield, VT 05673