



303 MESSNER DR. • WHEELING, IL • 60090
847-459-1460 • FAX 847-459-1569
WWW.LUND-INDUSTRIES.COM

AT-1100 Headlight Flasher - DRL Compatible

ALTERNATING ELECTRONIC FLASHER COMPATIBLE WITH DAYTIME RUNNING LIGHTS

ROAD RUNNER/Compatible (ETRR00C) - POWER PULSE/Compatible (ETPP00C)
Q SWITCH/Compatible (ETQS00C)

Congratulations! You are now the proud owner of the most technically advanced DRL Compatible Alternating Headlight Flasher System in the market today. Add to it our never ending commitment to quality, this new Flasher System will provide you with years of dependable trouble free service.

NOTE

Please refer to the Non-Compatible Vehicle List before attempting installation. This Flasher WILL NOT work on any ground side switched system. If you have any questions regarding what type of system your vehicle has, contact Sound Off, Inc.'s Technical Support Department at 1-800-338-7337.

A properly installed Alternating Electronic Flasher will alternate the vehicle's headlights at 1.9 flashes per second for the Road Runner, 3.0 f.p.s. for the Power Pulse and will continuously cycle through three flash patterns for the Q-Switch: a double flash wig wag (alternating) at 1.9 f.p.s., a simultaneous (modulating) flash at 3.0 f.p.s., and a fast wig wag (alternating) flash at 3.0 f.p.s.

When used at night, the low beam headlights remain ON for proper illumination, while the high beam lights flash to gain attention and increase the vehicle's visibility. When the dimmer switch is activated to high beam, the Flasher System's "High Beam Override" interrupts the Flasher sequence to allow for normal high beam function. Flashing automatically resumes when the dimmer switch is deactivated. The Flasher will automatically turn OFF the vehicle's DRL System when the Flasher is activated.

NOTE

Flashing Headlight and Taillight Systems are intended for use on approved vehicles ONLY. It is the responsibility of the user of these systems to insure compliance to any Federal, State or Municipal regulations which may apply.

INSTALLATION

MOUNTING: Mount the Flasher so that the maximum amount of air will flow across it, typically in the front passenger side of the engine compartment.

GREEN WIRE: Connect to a convenient, reliable ground.

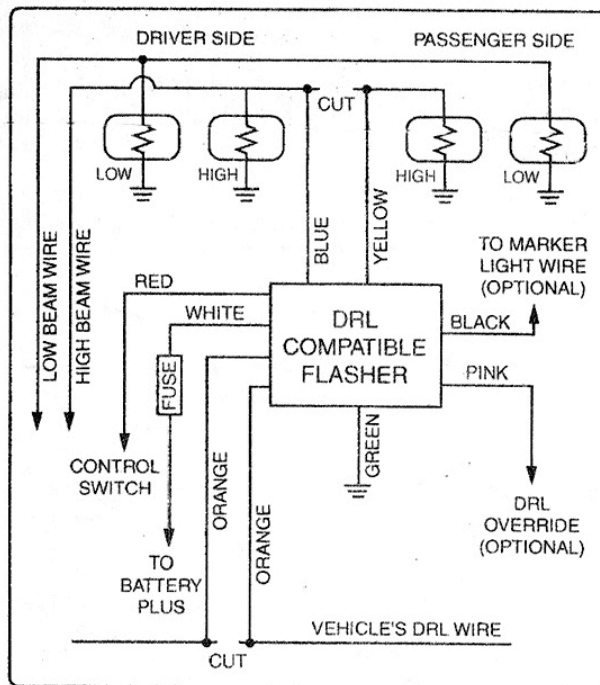

WIRING SCHEMATIC

NOTE

Always connect the green wire FIRST when installing and disconnect LAST when removing.

BLUE & YELLOW WIRE: Locate the wire that supplies power to the passenger side high beam headlight. Cut this wire approximately 10" to 12" from the back of the headlight. Connect the Flasher's yellow wire to the wire that returns to the passenger side high beam. Connect the blue wire to the wire that returns to the driver side high beam.

RED WIRE: Connect to a user supplied single pole, single throw switch. Connect the other side of the switch to a 12Vdc source. This switch will only require a 1/4 amp to activate the Flasher.

WHITE WIRE: Connect through an ATO type fuse (20 amp) to the positive post of the battery. DO NOT USE A CIRCUIT BREAKER, FUSIBLE LINK OR SLOW BLOW TYPE FUSE.

NOTE

Older 4 bulb Sealed Beam Headlight Systems may require a 30 amp fuse. Call Sound Off, Inc.'s Technical Support Department at 1-800-338-7337 for any further assistance.

NOTE

DO NOT connect the red and white wires together. The white wire must receive a constant source of power at all times.

ORANGE WIRES: Find the DRL input or output wire. "T" or tap both orange wires into it. Cut the wire between the two orange wires and tape.

BLACK WIRE (OPTIONAL): If an "Automatic Nighttime Flasher Cut off" is required (check State and Municipal regulations), simply "T" or tap the black wire into the parking light wire. If not required, connect the black wire to ground.

PINK WIRE (OPTIONAL): Connect to the HOT side of a user supplied switch, the parking brake switch or the neutral safety switch. When the pink wire is grounded through one of the switches, the DRL function and marker light will be deactivated.

NON-COMPATIBLE FLASHER VEHICLE LIST

Buick Century	1997 and Later
Buick Regal	1996 and Later
Chevy Blazer	1998 and Later
Chevy Cavalier	1995 and Later
Chevy CK	1999 and Later
Chevy Malibu	1996 and Later
Chevy S10	1998 and Later
Chrysler Sebring	1997 and Later
Dodge Avenger	1997 and Later
Dodge Durango	1999 and Later*
Dodge Ram	1999 and Later*
Dodge Dakota	1999 and Later*
Most Japanese Vehicles	
Oldsmobile Ciera	1998 and Later
Oldsmobile Cutlass	1998 and Later
Oldsmobile Intrigue	1998 and Later
Saturn	ALL

***NOTE:** 2001 and later Dodge Durango, Dakota and 2002 Dodge Ram 1500-1/2 Ton trucks require a special Dodge Flasher ET3PFISO00-P.

WARRANTY

Sound Off, Inc. warrants the ETRR00C, ETPP00C and ETQS00C Electronic Flasher Systems for one (1) full year from the date of purchase to the original purchaser against any manufacturer defects or workmanship. This warranty applies only to units installed according to manufacturer's installation instructions and operated within the units specifications.

Warranty is void if the unit was installed incorrectly or maliciously damaged.

All warranty claims must be accompanied by a dated proof of purchase.

Sound Off, Inc. retains the right to be the sole mediator of what constitutes defects in performance or manufacturing.

Covered under U.S. Patents #4114071 and #4309639