



MODEL G8586 PORTABLE CLAMPING WORKBENCH INSTRUCTIONS

Introduction

This workbench features four adjustable clamping dogs for securing flat work, independently adjustable hand screws for irregular clamping, and folding capability for convenient storage.

Specifications

Weight 18 lbs.
 Dimensions 31¼"H x 24"W x 25"D
 Clamping Capacity 4¼"
 Work Surface 24" x 9½"

Inventory

	Qty
A. Front Table Top.....	1
B. Rear Table Top	1
C. Table Brackets	2
D. Crossbars	2
E. Leg Frames	2
F. Clamping Dogs.....	4
G. Rubber Feet	4
H. Hardware Bag (not shown)	
—Tap Screws 5 x 14mm	16
—Phillip Head Screws M6-1 x 40	8
—Hex Nuts M6-1	8
—Flat Washers 6mm	16
—Hex Bolts M8-1.25 x 45	4
—Lock Nuts M8-1.25	4
—Flat Washers 8mm	8

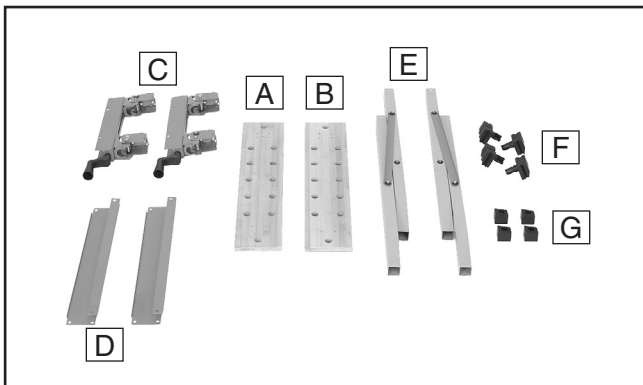

Figure 1. Model G8586 inventory.

Assembly

1. Attach the crossbars to the leg braces with (8) M6-1 x 40 Phillips head screws, hex nuts and (16) 6mm flat washers, as show in **Figure 2**.

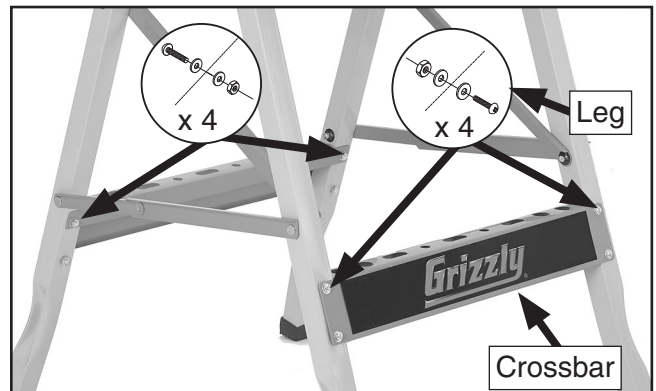

Figure 2. Crossbars and legs assembled.

2. Press the release button on a table bracket (**Figure 3**), swing it open, then place the bracket on the bottom of the front table top. Position the handle on the side of the table top with the measuring scale.

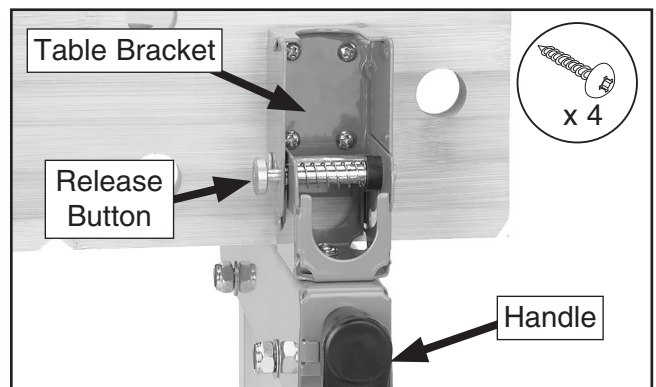

Figure 3. Table bracket installed on bottom of front table top.

3. Secure the table bracket to the front table top with (4) tap screws, as shown in **Figure 3**.

COPYRIGHT © MAY, 2008 BY GRIZZLY INDUSTRIAL, INC.

WARNING: NO PORTION OF THIS MANUAL MAY BE REPRODUCED IN ANY SHAPE OR FORM WITHOUT THE WRITTEN APPROVAL OF GRIZZLY INDUSTRIAL, INC.

#BL10763 PRINTED IN CHINA

4. Install the other table bracket on the opposite end of the table top in a similar manner.
5. Repeat **Steps 2-4** to secure the table brackets to the bottom of the rear table top.
6. Place the table assembly onto the leg braces, align the mounting holes, then secure with (4) M8-1.25 x 45 hex bolts, hex nuts, and (8) flat washers, as shown in **Figure 4**.

7. Install the rubber feet on the legs (**Figure 4**) so the longest side of each foot is at the corner.
8. Install the clamping dogs (**Figure 4**) in the holes on the table tops, as required, to hold your workpiece.

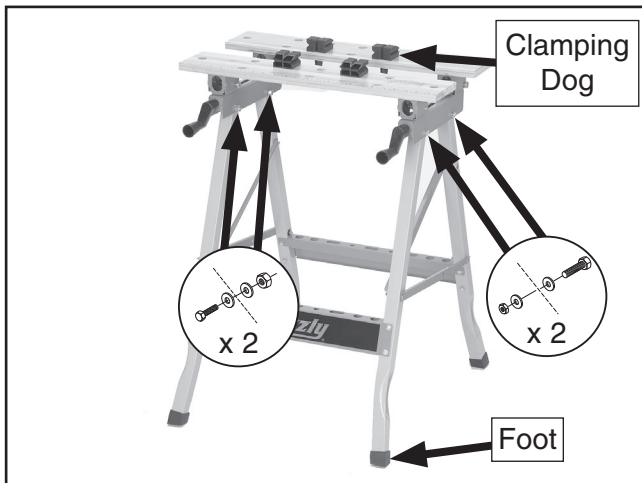

Figure 4. Legs fastened to table assembly.

Operation

Turn the hand cranks to adjust the table tops for clamping workpieces between the tables or between the clamping dogs using the V-shaped recesses.

CAUTION

DO NOT use the Model G8586 as a step-ladder. Doing so could cause serious personal injury.

NOTICE

Never exceed the listed capacity of the workbench; doing this could break it.

G8586 Parts Breakdown

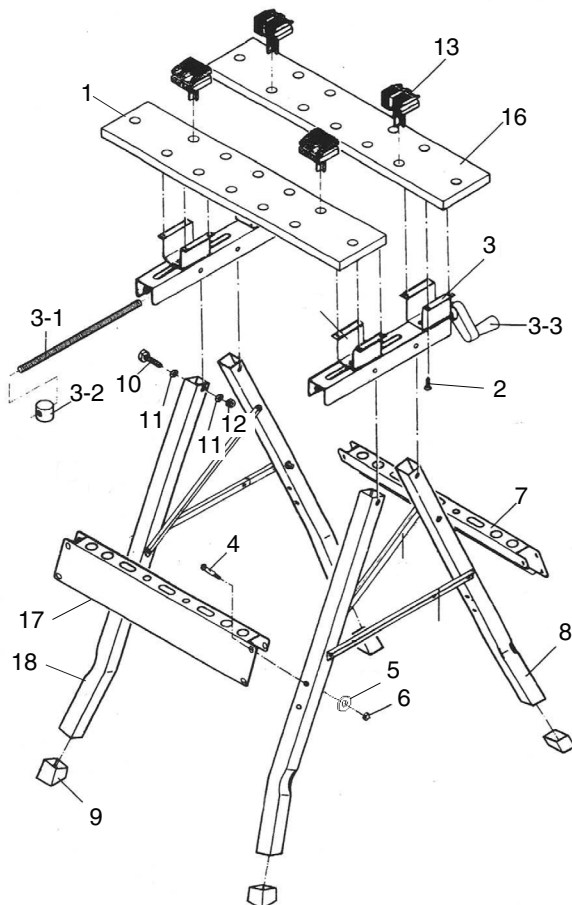

REF	PART #	DESCRIPTION
1	P8586001	TABLE TOP (REAR)
2	PHTEK20M	TAP SCREW M5 X 14
3	P8586003	TABLE BRACKET
3-1	P8586003-1	THREADED ROD
3-2	P8586003-2	THREADED SOCKET
3-3	P8586003-3	TABLE BRACKET HANDLE
4	PS81M	PHLP HD SCR M6-1 X 40
5	PW03M	FLAT WASHER 6MM
6	PN01M	HEX NUT M6-1
7	P8586007	CROSSBAR (FRONT)
8	P8586008	LEG FRAME (R)
9	P8586009	RUBBER FOOT
10	PB15M	HEX BOLT M8-1.25 X 40
11	PW01M	FLAT WASHER 8MM
12	PLN04M	LOCK NUT M8-1.25
13	P8586013	CLAMPING DOG
16	P8586016	TABLE TOP (FRONT)
17	P8586017	CROSSBAR (REAR)
18	P8586018	LEG FRAME (L)

