

USERS GUIDE LO-21P

LOCK OUT RELAY

PRODUCT DESCRIPTION

The microprocessed LO-21P (PN: 10LO21P) Lock Out Relay is designed to provide a lockout function for the BEA Bodyguard presence sensor, when used with the complete Parallax System. The LO-21P uses the motor and Bodyguard to determine if the swing path of the automatic door is clear and allows the door to open or close. If the swing path of the automatic door is not clear and the door is in the open position, the LO-21P will allow the Bodyguard to hold the door open as long as it detects something. If the door is closed and there is something in the Bodyguard pattern, the LO-21P will prohibit the activation device from opening the door.

TECHNICAL SPECIFICATIONS

DESCRIPTION	SPECIFICATIONS
Power Supply	12-24 Volts AC/ DC
Operating Frequency	4 MHz (Microprocessor)
Power Consumption	10 mA at rest, 50 mA Max.
Output	SPST Relay
Max. Voltage - Relay Contact	60V DC, 120V AC
Max. Current - Relay Contacts	2A DC, 0.5A AC

COMPONENT ID

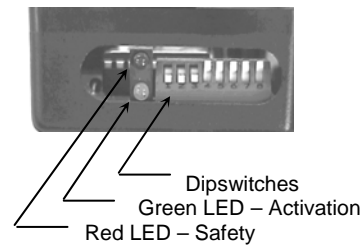

SAFETY PRECAUTIONS



- Shut off all power going to the header before attempting any wiring procedures.
- Maintain a clean & safe environment when working in public areas.
- Constantly be aware of pedestrian traffic around the door area.
- Always stop pedestrian traffic through the doorway when performing tests that may result in unexpected reactions by the door.
- Always check placement of all wiring before powering up to insure that moving door parts will not catch any wires and cause damage to equipment.
- Ensure compliance with all applicable safety standards (i.e. ANSI A156.10) upon completion of installation.

WIRE CONNECTIONS

Black	Motor Input -
Red	Motor Input +
Purple	Bodyguard COM. Pin 3
White	Bodyguard Data (-) Pin 6
Black / White	Activation Sensor COM.
Orange	Power input / 12-24 VAC/VDC (-)
Gray	Bodyguard N.O. Pin 4
Red / White	Bodyguard Data (+) Pin 7 & Activation Sensor N.O.
Brown	Power input / 12-24 VAC/VDC (+)
Green	Door Control Common
Blue	Door Control Activation
Yellow	Door Control safety

LO-21P WIRING DIAGRAMS:

STANDARD WIRING

The wiring shown below may be used on most models of operators. See wiring diagrams at back of this manual for specific diagrams.

BODYGUARD

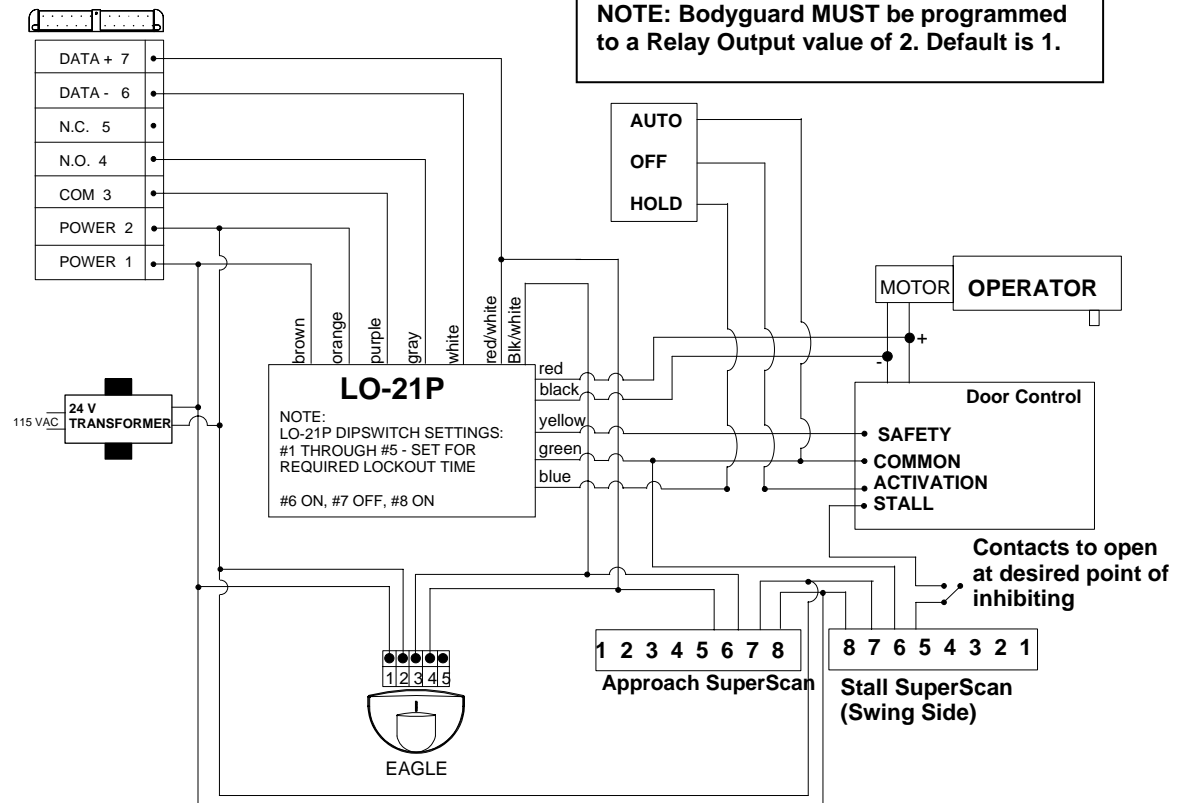

IMPORTANT:

Before connecting the red and black wires from the LO-21P to the Motor, be sure to check the polarity of the voltage with a multi-meter, to determine which wire is the positive side. The red wire of the lockout module must always be connected to the positive side of the motor. When a positive reading is observed on the meter, (while the door is in hold open) the red probe indicates the positive side. Thus, the red wire of the lockout will always be attached to whatever wire the red probe was on when a positive reading was obtained.

NOTES:

- For pairs of doors, wire the additional SuperScans the same as shown above.
- For the inhibit function, operator mounted auxiliary switches may be used – dry contacts only.
- Bodyguard must be programmed to a relay value of 2.

**ELECTRICAL
INSTALLATION
OPTION 2 –
Operator Mounted
Switch**

Wiring diagram below shows how to wire when using an operator-mounted switch to control the flow of voltage from the motor to the lockout module. Switch should be set to close a set of dry contacts when door is within 2 to 3 degrees of the full open position.

BODYGUARD

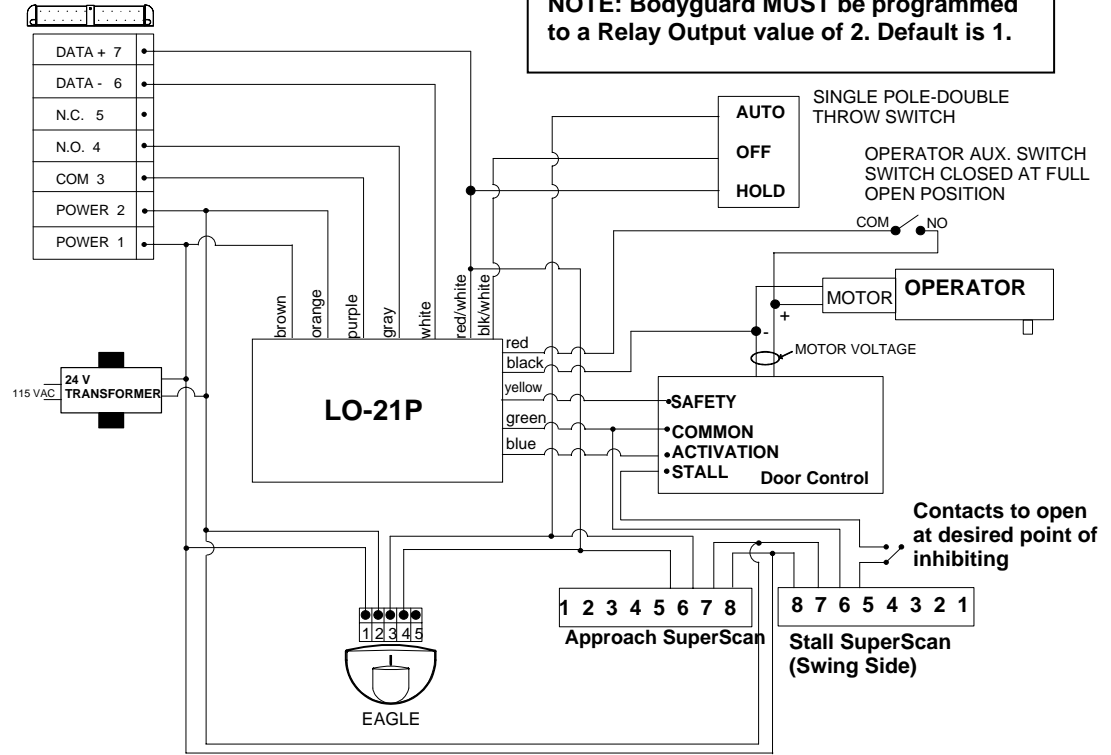

NOTE: Bodyguard MUST be programmed to a Relay Output value of 2. Default is 1.

IMPORTANT:
Before connecting the red and black wires from the LO-21P to the Motor, be sure to check the polarity of the voltage with a multi-meter, to determine which wire is the positive side. The red wire of the lockout module must always be connected to the positive side of the motor. When a positive reading is observed on the meter, (while the door is in hold open) the red probe indicates the positive side. Thus, the red wire of the lockout will always be attached to whatever wire the red probe was on when a positive reading was obtained.

NOTES:

- For pairs of doors, wire the additional SuperScans the same as shown above.
- For the inhibit function, operator mounted auxiliary switches may be used – dry contacts only.
- Bodyguard must be programmed to a relay value of 2.

**ELECTRICAL
INSTALLATION**
Option 3 – Double
Pole Double Throw
Switch

The wiring diagram below shows how to wire a DPDT switch to control the On-Off-Hold function, as well as data between the motor and the LO21P.

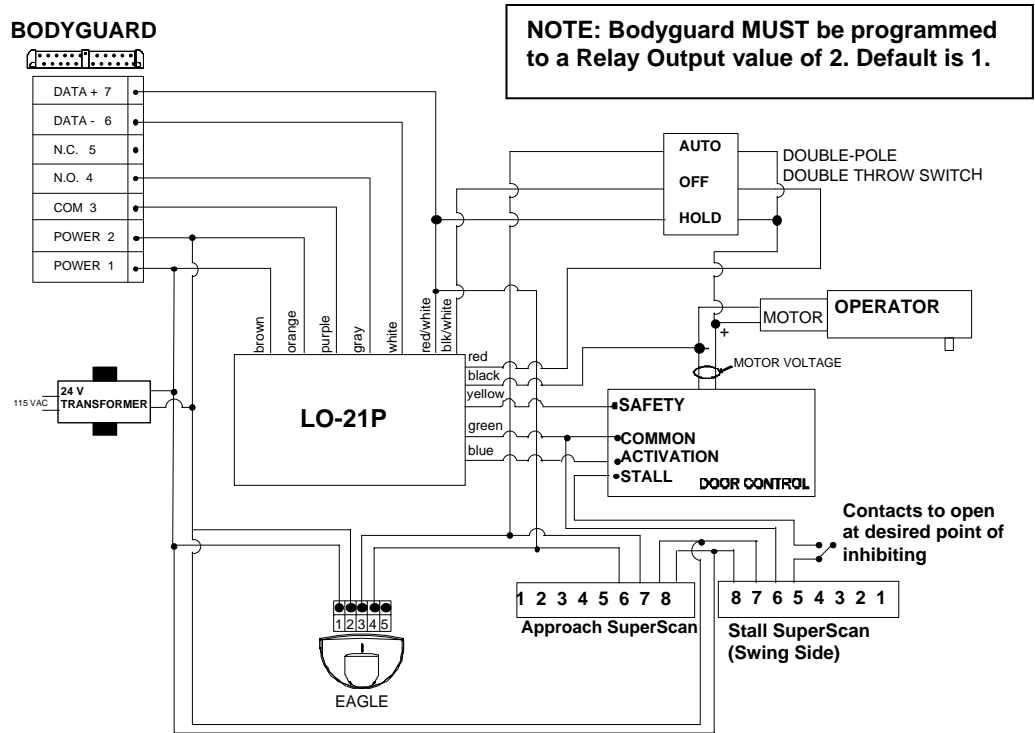

IMPORTANT:

Before connecting the red and black wires from the LO-21P to the Motor, be sure to check the polarity of the voltage with a multi-meter, to determine which wire is the positive side. The red wire of the lockout module must always be connected to the positive side of the motor. When a positive reading is observed on the meter, (while the door is in hold open) the red probe indicates the positive side. Thus, the red wire of the lockout will always be attached to whatever wire the red probe was on when a positive reading was obtained.

NOTES:

- For pairs of doors, wire the additional SuperScans the same as shown above.
- For the inhibit function, operator mounted auxiliary switches may be used – dry contacts only.
- Bodyguard must be programmed to a relay value of 2.

**SET-UP
INSTRUCTIONS**

Upon completion of all wiring, proceed with the set-up as follows:

1. Insure that the On-Off-Hold Open switch is in the ON position, and insure that the door control is powered and operating normally.
2. **Power the Bodyguard sensor and, using a BEA Remote Control, unlock the sensor and change the Output Configuration to a value of 2. If necessary, refer to the Bodyguard User's Guide for programming instruction.**

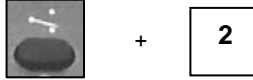

3. Power the LO-21P on with 12-24 VAC/VDC, and insure all sensors or other devices in the application are properly powered
4. Observe the green LED on the Bodyguard upon powering. With the door in the closed position, the green LED should begin blinking, then expire approximately 5 seconds thereafter to indicate a successful set-up for the closed-door position.
5. Activate the door to the open position, the Bodyguard should once again begin flashing green, then expire approximately 5 seconds thereafter to indicate a successful set-up for the open-door position. If the door goes into safety swing as soon as it starts to close and you have a time delay set for the length of the closing cycle, reverse the black and red wires to the motor input for DC units. Correct any faults before proceeding.



If the Bodyguard learns a "door closed" position, but does not execute a set-up for the "open door position", place the door to a hold open position. With a BEA remote control, unlock the Bodyguard, and with the door in the open position, press the Magic Wand key and then the number 2 – the Bodyguard should begin flashing green to signify a set-up. If it does not, this will be a quick indication that the improper data is being sent for the "open door" position. Check to insure that data exists on the data lines leading into the Bodyguard. In the full open position, voltage should be approximately 9 to 12 volts DC. If it is not, check the data lines (White wire on terminal 6 and Red/White wire on terminal 7) for correct voltage (see chart).

CLOSED DOOR	OPEN DOOR	CLOSING DOOR
0 Volts DC	9 to 12 Volts DC	8 Volts DC

To perform a quick test by remote control to check motor wire polarity, perform the following:

- Place On-Off-Hold switch in the ON or AUTO position.
 - Activate the door and immediately walk into the Bodyguard detection pattern while door is open. Door should be holding open at this point. Make sure there is no Eagle activation during this time.
 - Unlock the Bodyguard and press Magic Wand + 2. Green LED will begin flashing – If door closes while flashing green, check for correct polarity at the red and black wire from lockout.
6. Once the Bodyguard has learned the open and closed door positions, observe the green and red LED's on the LO-21P. Walk in and out of the field of detection for the Bodyguard while the door is open, and then again when it is closed. The LED's indicate the following:

- ❑ **GREEN LED:** The green LED, when illuminated, indicates that there is detection at the Bodyguard while the door is in the open position.
If someone steps into the Bodyguard detection zone when the door is open, the LO-21P's Green LED will illuminate to indicate that the Bodyguard will be connected to the activation circuitry of the door, thus holding the door open as long as there is detection.
Green LED will also illuminate when the activating device (Eagle) is triggered, or when On-Off-Hold Open switch is placed to the Hold Open position.
- ❑ **RED LED:** The red LED, when illuminated, indicates that there is detection at the Bodyguard while the door is in the closed position. It may also indicate that there is an activation signal from the Eagle or the Hold Open switch.

When the door is closed, and someone steps into the detection zone of the Bodyguard, the red LED on the LO-21P will illuminate, indicating that it will ignore any activation signal it receives. Therefore, the door will remain closed until the Bodyguard detection zone is clear. Once the Bodyguard zone is clear and the door has been activated it will open and remain open for the hold time set by the motion sensor and/or door control, and will also hold open during detection at Bodyguard.

**SETUP
INSTRUCTION
Cont.**

7. Adjustment is necessary to configure the dipswitches to obtain the correct lock out time delay. To set the dipswitches(1 through 5) for lock out time, perform the following:
 - Activate the door to the open position.
 - Time the overall door closing cycle
 - Configure the dip switches according to the chart on Page 4 for the lockout time that is required
 - Activate the door again to the open position
 - Stand outside of the Bodyguard detection pattern, and while the door is closing, observe the red LED on the Bodyguard
 - The red LED on the Bodyguard should NOT illuminate during the closing cycle. If it does, it is probably seeing the door at the very last degree or two of door closing, which would indicate that the lock out time needs to be slightly increased.
 - Reconfigure the dipswitches to add 1 second of lock out time.
 - When the lock out time is correct. The red LED will not illuminate during the entire closing cycle of the door.
8. The last test is to insure that the Bodyguard detects an object as soon as the door has stopped closing. Simply allow the doors to begin closing, and step in behind the doors, into the Bodyguards field of detection. The red LED shall illuminate and remain on at the Bodyguard, and at the LO-21P, as soon as the door reaches the fully closed position, provided that an object remains in the Bodyguard's detection field.
9. Set the dipswitches according to the chart below to achieve the desired lockout time. The total lockout time is the sum total of the dipswitches that are in the ON position. For easy reference, use the timetables below. Default time is 7 seconds (times are approximate).

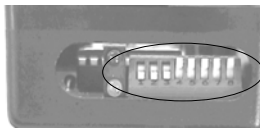

Dipswitch #	Time Delay (seconds)
1	1
2	2
3	4
4	8
5	16

**DIPSWITCH
6, 7 and 8
OPERATION**

Time Delay (sec)	dip 1 1 sec	dip 2 2 sec	dip 3 4 sec	dip 4 8 sec	dip 5 16 sec
1	on	off	off	off	off
2	off	on	off	off	off
3	on	on	off	off	off
4	off	off	on	off	off
5	on	off	on	off	off
6	off	on	on	off	off
7	on	on	on	off	off
8	off	off	off	on	off
9	on	off	off	on	off
10	off	on	off	on	off
11	on	on	off	on	off
12	off	off	on	on	off
13	on	off	on	on	off
14	off	on	on	on	off
15	on	on	on	on	off
16	off	off	off	off	on

Time Delay (sec)	dip 1 1 sec	dip 2 2 sec	dip 3 4 sec	dip 4 8 sec	dip 5 16 sec
17	on	off	off	off	on
18	off	on	off	off	on
19	on	on	off	off	on
20	off	off	on	off	on
21	on	off	on	off	on
22	off	on	on	off	on
23	on	on	on	off	on
24	off	off	off	on	on
25	on	off	off	on	on
26	off	on	off	on	on
27	on	on	off	on	on
28	off	off	on	on	on
29	on	off	on	on	on
30	off	on	on	on	on
31	on	on	on	on	on

Dipswitch 6 Position	Description of Performance
ON (Default)	The LO21P expects to see voltage coming in at the red and black wire while the door is in the Open position. Typical for DC motors.
OFF	The LO21P expects to see voltage coming in at the red and black wire while the door is in the Closed position.

Dipswitch 7 and 8 Position	Description of Performance
7 OFF / 8 ON (Default)	The LO21P CLOSES the Safety circuit (yellow wire) upon a Bodyguard Detection during the door closed position
7 ON / 8 OFF	The LO21P OPENS the Safety circuit (yellow wire) upon a Bodyguard Detection during the door closed position

TROUBLE-SHOOTING

PROBLEM	PROBABLE CAUSE	CORRECTIVE ACTION
Door will not open – all LED's are OFF at the LO21P	<ol style="list-style-type: none"> 1. Faulty door control 2. Faulty LO21P 3. Faulty On-Off-Hold Open switch 4. Faulty Eagle 5. Faulty wiring 	<ol style="list-style-type: none"> 1. Insure input power is good at LO21P – orange and brown wires. Should be 12 to 24 volts AC or DC. 2. Go directly to door control and jumper common and activation input. If door opens, proceed to next step. If not, replace/repair faulty door control. 3. Go to LO21P and jumper the red/white striped wire to the black/white striped wire. Green LED on LO21P should come on, and door should open. If not, replace LO21P. If LED comes on, but door does not open, check to insure that the blue and green wires are connected to the door control properly. 4. Check to insure that On-Off-Hold Open switch is functioning properly. 5. Check Eagle sensor for proper operation. Jumper common and N.O. terminals while wires are attached. If door does not open, check wiring between Eagle and LO21P.
Door will not open – red LED is ON at LO21P	<ol style="list-style-type: none"> 1. Bodyguard is in detection 2. Bodyguard not programmed properly 3. Faulty wiring between Bodyguard and LO21P 	<ol style="list-style-type: none"> 1. Launch a setup on Bodyguard 2. Insure Bodyguard relay output is programmed to a value of 2. Default is 1. 3. When Bodyguard is in detection, an open circuit occurs at the purple and gray wires on the LO21P. Thus if there is any break in wiring between purple and gray and the LO21P, the lockout will react the same as if the Bodyguard were in detection. Insure there are no breaks in the wiring.
Door will not close	<ol style="list-style-type: none"> 1. On-Off-Hold Open switch is in Hold Open position 2. Bodyguard is in detection 3. Faulty door control 	<ol style="list-style-type: none"> 1. Place switch in On or Auto position 2. Launch a setup at Bodyguard 3. Remove wire from common and activate terminal at door control, if door does not close, replace/repair faulty control.
Bodyguard keeps re-learning with each door position	<ol style="list-style-type: none"> 1. Incorrect data polarity at Bodyguard 2. Insufficient voltage switching at red and black wire of LO21P 	<ol style="list-style-type: none"> 1. Insure that the white wire goes to terminal 6 of the Bodyguard, and the red/white striped wire goes to terminal 7 of the Bodyguard 2. When door is closed, there should be 0 volts observed on the red and black wires of the LO21P. When the door is open, voltage should be greater than approximately 9 volts. If voltage is not great enough at red and black wires when door is open, the LO21P will not be able to send the correct data to the Bodyguard. Remember, polarity must also be correct. The red wire must ALWAYS connect to the positive wire of the motor, as observed during door open position. See important note on page 2.
As the door is closing, the Bodyguard, upon seeing the closing door, seems to reactivate the door to the open position	<ol style="list-style-type: none"> 1. Dipswitch 6 at LO21P is in wrong position 	<ol style="list-style-type: none"> 1. Place dipswitch 6 in opposite position and re-test the door

IMPORTANT NOTE: When experiencing sensor system problems, it is recommended to disable the main power supply as to fully disable the system, until necessary repairs can be made.

COMPANY CONTACT



Do not leave problems unresolved. If a satisfactory solution cannot be achieved after troubleshooting a problem, please call B.E.A., Inc. If you must wait for the following workday to call B.E.A., leave the door inoperable until satisfactory repairs can be made. Never sacrifice the safe operation of the automatic door or gate for an incomplete solution.

The following numbers can be called 24 hours a day, 7 days a week. For more information, visit www.beasensors.com.

West: 1-888-419-2564 **Mid-West: 1-888-308-8843**
South-East: 1-800-407-4545 **North-East: 1-866-836-1863**
US and Canada: 1-866-249-7937 **Canada: 1-866-836-1863**

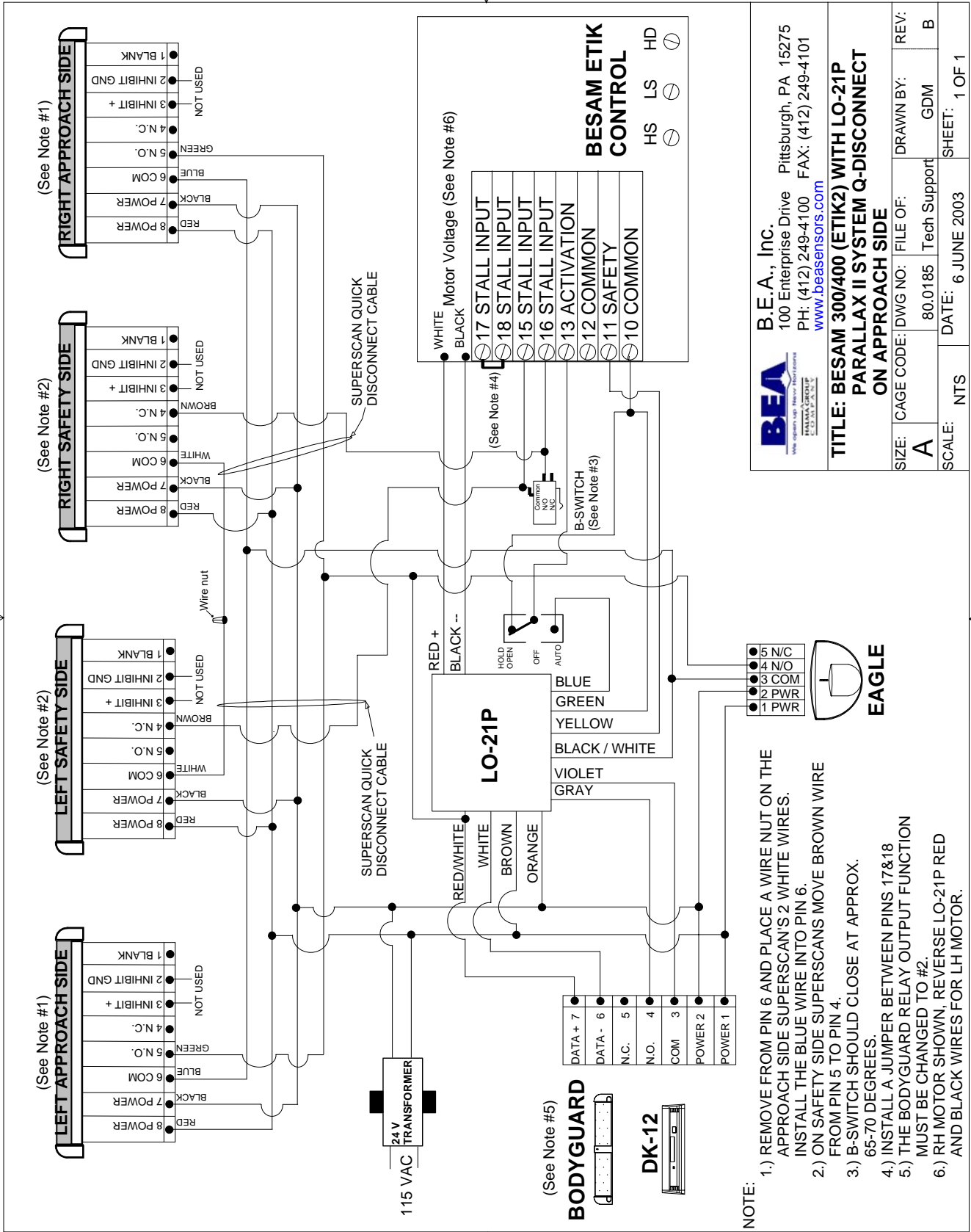

B.E.A., Inc.
 100 Enterprise Drive Pittsburgh, PA 15275
 PH: (412) 249-4100 FAX: (412) 249-4101
www.beasensors.com

TITLE: BESAM 300/400 (ETIK2) WITH LO-21P PARALLAX II SYSTEM Q-DISCONNECT ON APPROACH SIDE

SIZE: A	CAGE CODE: 80.0185	FILE OF: Tech Support	REV: B
SCALE: NTS	DATE: 6 JUNE 2003	SHEET: 1 OF 1	

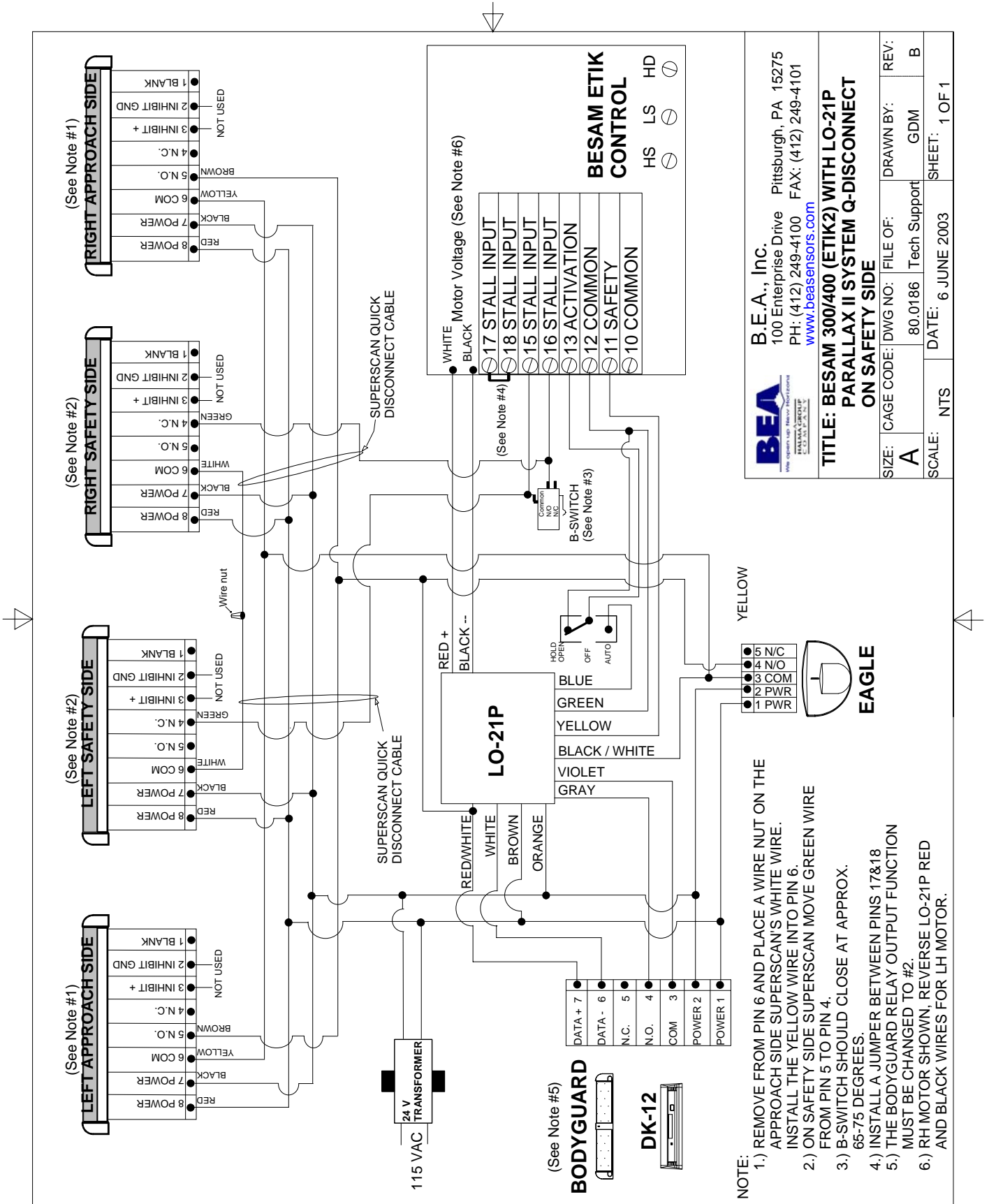

B.E.A., Inc.
 100 Enterprise Drive Pittsburgh, PA 15275
 PH: (412) 249-4100 FAX: (412) 249-4101
www.beasensors.com

TITLE: BESAM 300/400 (ETIK2) WITH LO-21P PARALLAX II SYSTEM Q-DISCONNECT ON SAFETY SIDE

SIZE: A	CAGE CODE: 80.0186	DWG NO: Tech Support	FILE OF: GDM	DRAWN BY: B	REV:
SCALE: NTS	DATE: 6 JUNE 2003	SHEET: 1 OF 1			

- NOTE:**
- 1.) REMOVE FROM PIN 6 AND PLACE A WIRE NUT ON THE APPROACH SIDE SUPERSCAN'S WHITE WIRE. INSTALL THE YELLOW WIRE INTO PIN 6.
 - 2.) ON SAFETY SIDE SUPERSCAN MOVE GREEN WIRE FROM PIN 5 TO PIN 4.
 - 3.) B-SWITCH SHOULD CLOSE AT APPROX. 65-75 DEGREES.
 - 4.) INSTALL A JUMPER BETWEEN PINS 17&18
 - 5.) THE BODYGUARD RELAY OUTPUT FUNCTION MUST BE CHANGED TO #2.
 - 6.) RH MOTOR SHOWN, REVERSE LO-21P RED AND BLACK WIRES FOR LH MOTOR.

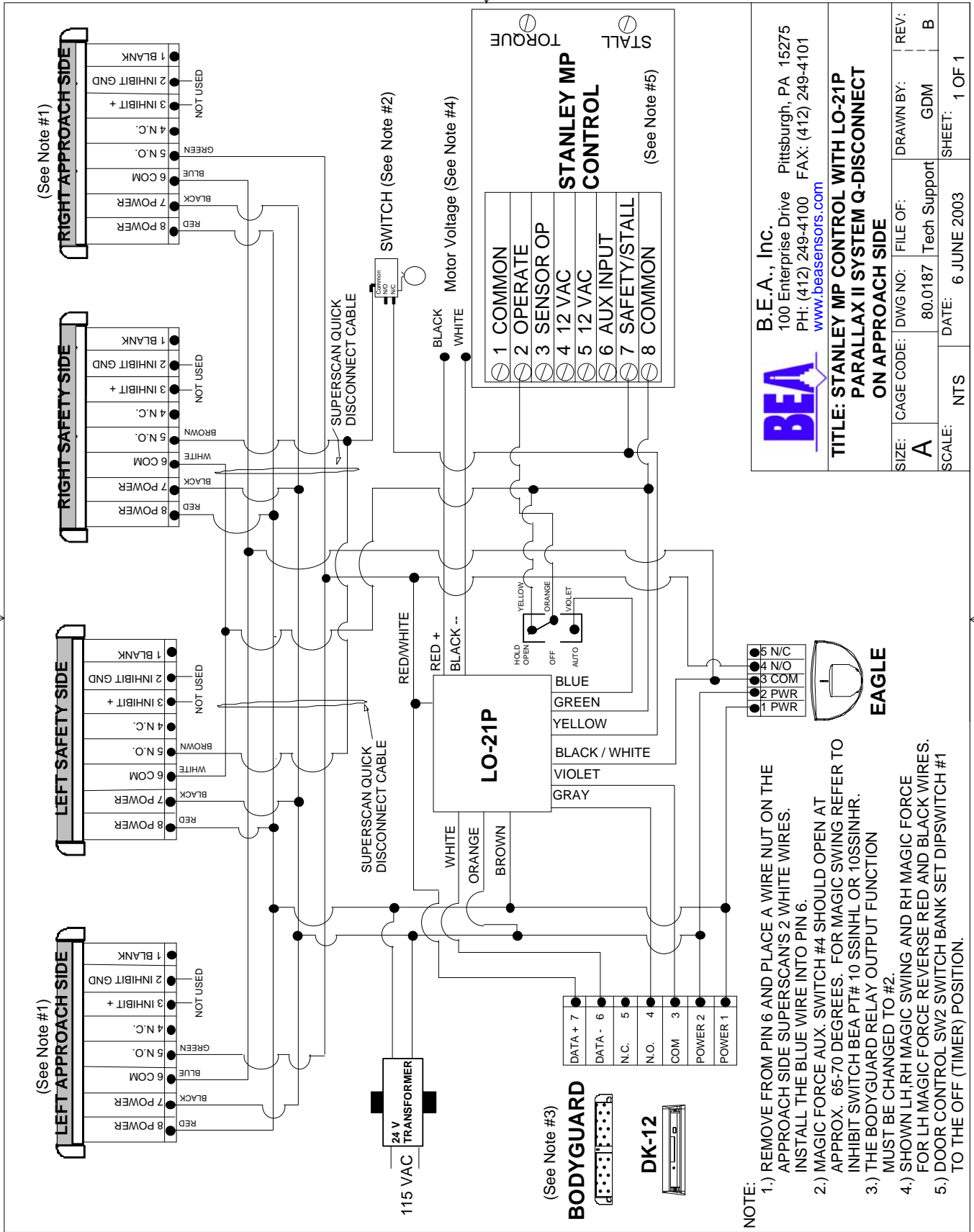

BEA
B.E.A., Inc.
100 Enterprise Drive Pittsburgh, PA 15275
PH: (412) 249-4100 FAX: (412) 249-4101
www.beasensors.com

TITLE: STANLEY MP CONTROL WITH LO-21P PARALLAX II SYSTEM Q-DISCONNECT ON APPROACH SIDE

SIZE: A	CAGE CODE: 80.0187	FILE OF: Tech Support	DRAWN BY: GDM	REV: B
SCALE: NTS	DATE: 6 JUNE 2003	SHEET: 1 OF 1		

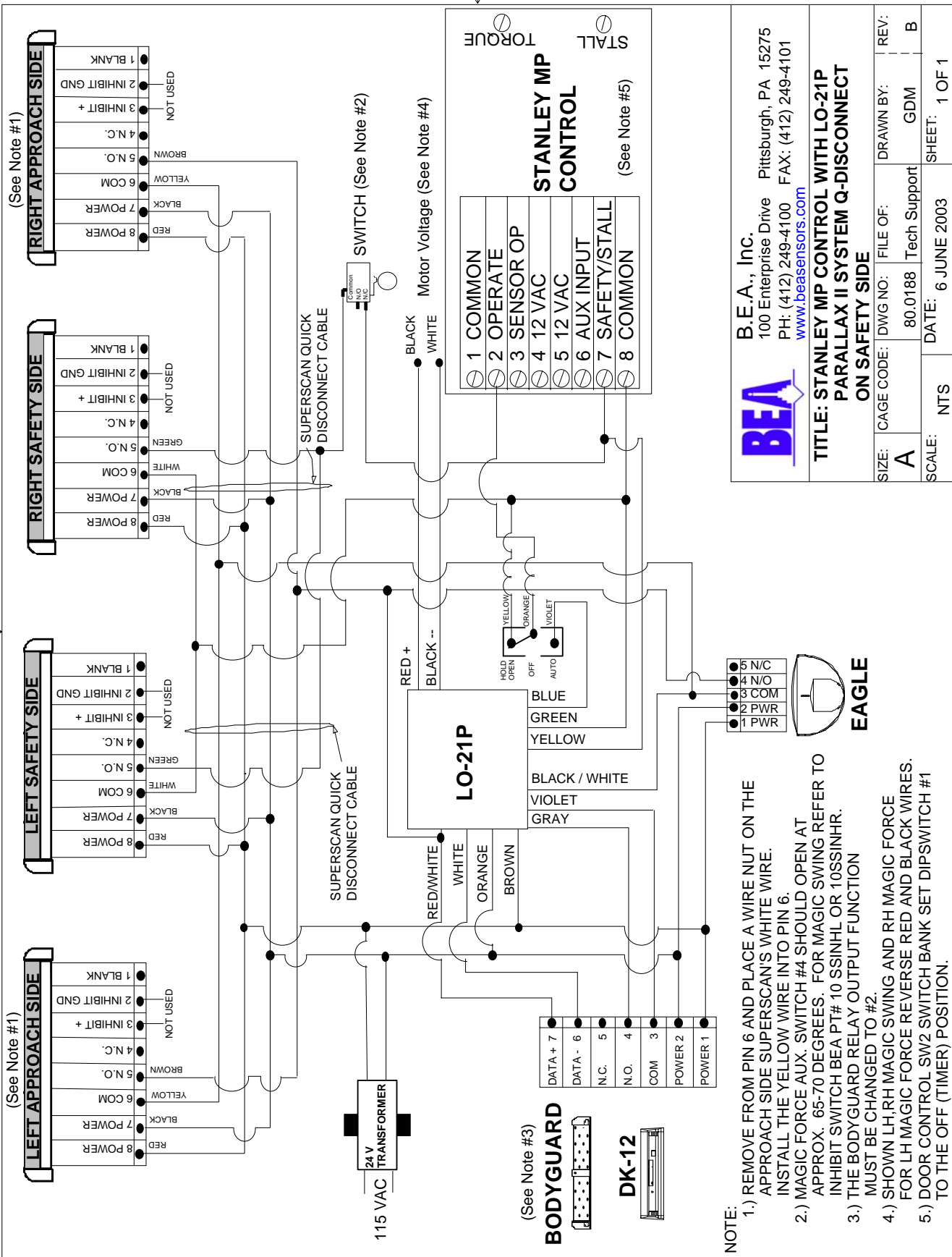

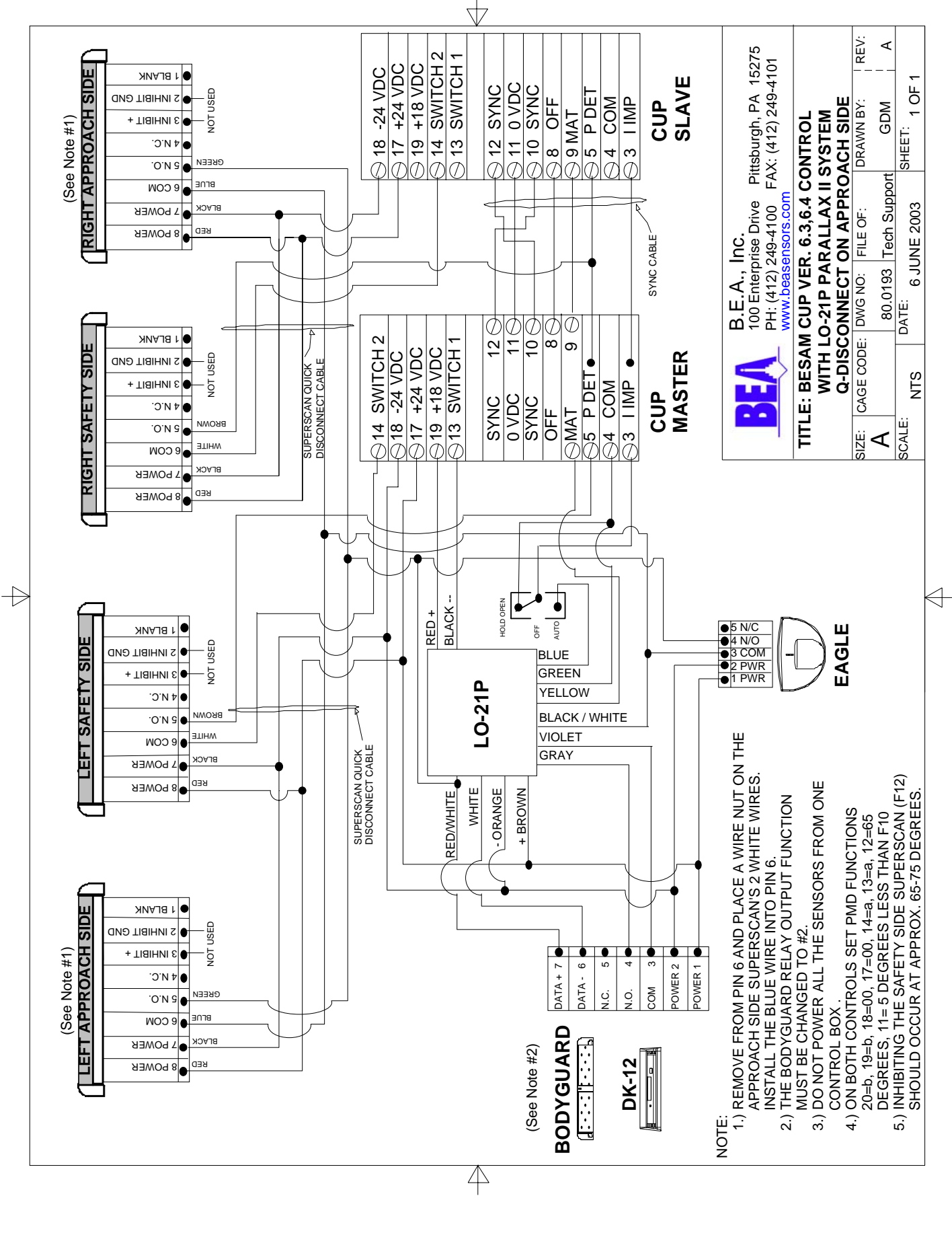

B.E.A., Inc.
 100 Enterprise Drive Pittsburgh, PA 15275
 PH: (412) 249-4100 FAX: (412) 249-4101
www.beasensors.com

TITLE: BESAM CUP VER. 6.3,6.4 CONTROL WITH LO-21P PARALLAX II SYSTEM Q-DISCONNECT ON APPROACH SIDE

SIZE: A	CAGE CODE: 80.0193	FILE OF: Tech Support	DRAWN BY: GDM	REV: A
SCALE: NTS	DATE: 6 JUNE 2003	SHEET: 1 OF 1		

- NOTE:**
- 1.) REMOVE FROM PIN 6 AND PLACE A WIRE NUT ON THE APPROACH SIDE SUPERSCAN'S 2 WHITE WIRES. INSTALL THE BLUE WIRE INTO PIN 6.
 - 2.) THE BODYGUARD RELAY OUTPUT FUNCTION MUST BE CHANGED TO #2.
 - 3.) DO NOT POWER ALL THE SENSORS FROM ONE CONTROL BOX.
 - 4.) ON BOTH CONTROLS SET PMD FUNCTIONS 20=b, 19=b, 18=00, 17=00, 14=a, 13=a, 12=65 DEGREES, 11= 5 DEGREES LESS THAN F10 DEGREES, 11= 5 DEGREES LESS THAN F10 DEGREES, 11= 5 DEGREES LESS THAN F10 DEGREES, 11= 5 DEGREES LESS THAN F10 DEGREES, 11= 5 DEGREES LESS THAN F10 DEGREES.
 - 5.) INHIBITTING THE SAFETY SIDE SUPERSCAN (F12) SHOULD OCCUR AT APPROX. 65-75 DEGREES.

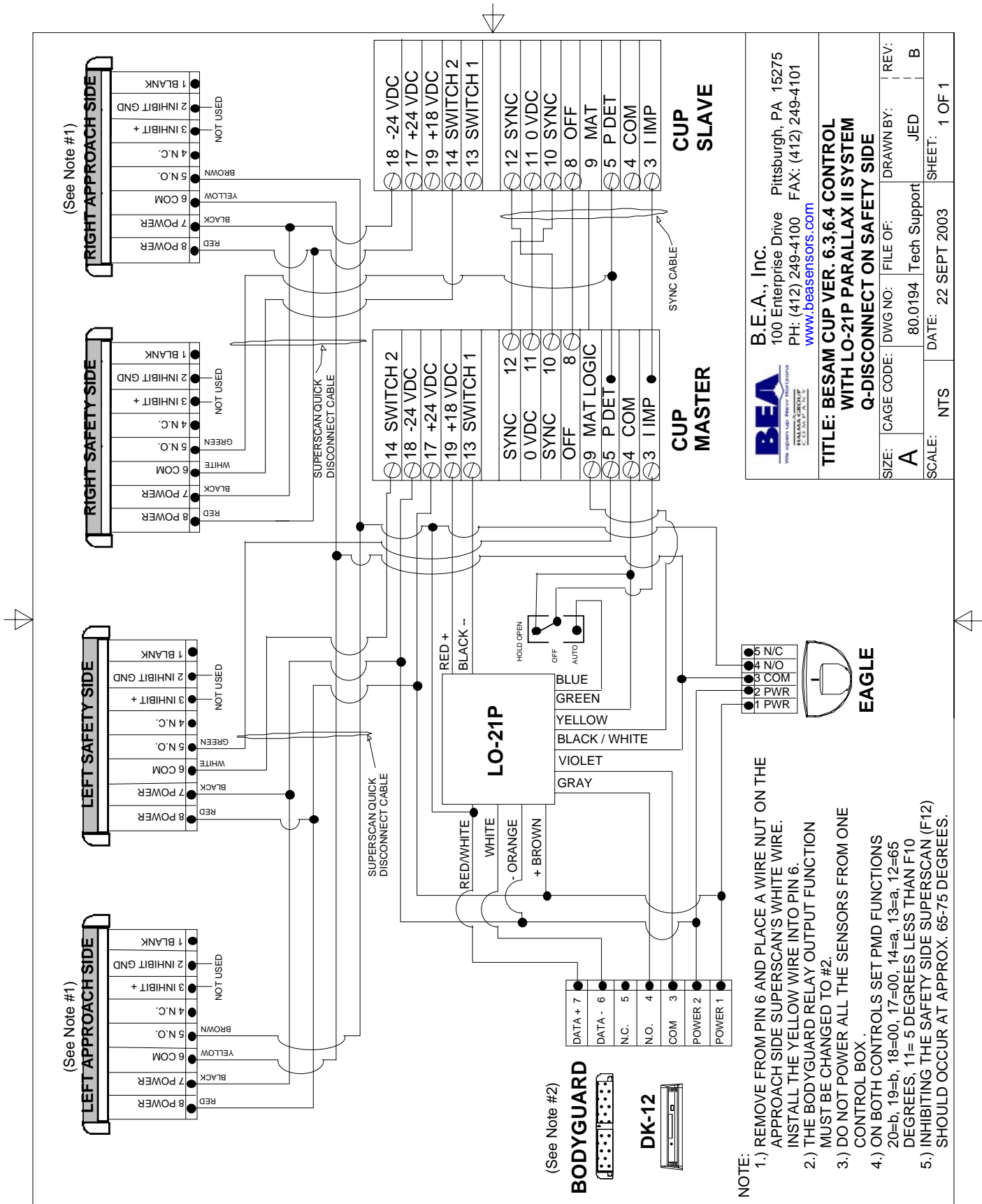

BEA
B.E.A., Inc.
100 Enterprise Drive Pittsburgh, PA 15275
PH: (412) 249-4100 FAX: (412) 249-4101
www.beasensors.com

TITLE: BESAM CUP VER. 6.3,6.4 CONTROL WITH LO-21P PARALLAX II SYSTEM Q-DISCONNECT ON SAFETY SIDE

SIZE: A	CAGE CODE: 80.0194	FILE OF: Tech Support	DRAWN BY: JED	REV: B
SCALE: NTS	DATE: 22 SEPT 2003	SHEET: 1 OF 1		