

# SABER

## ATD-80390

### Saber II 90-SMD LED Work Light Owner's Manual



#### Features And Specifications:

- 90 Super bright SMD LED
- 7.4V 1700mAh Li-ion rechargeable battery
- Up to 2.5~3 hours of continuous use
- With Automatic shut off and over charge protection, prolongs battery life
- Impact protection, ergonomic grip handle and bumper
- Easy operating switch
- 2pcs 360 degree rotating hook easy for working used
- UL listed Charger

#### Operating instructions

- To use, plug the unit into any 110-120 VAC power source, such as a wall receptacle. Let the unit fully charge until the green indicator on the charger turns on before use.
- Charge this light every month if not in constant use, and after each use, it is used often to insure longevity.
- Press the switch at the bottom of the handle to turn unit on, press the switch again to turn it off.

#### Cautions

- For indoor use only - don't use in or around tubs, showers, sinks, pools, hot tubs, or in a wet environment
- Use only the recommended voltage and frequency requirements
- Keep out of reach of children
- Do not operate light with wet hands.
- Keep lamp away from hot objects.

Made in China to ATD Tools, Inc. Specifications



## ATD-80390

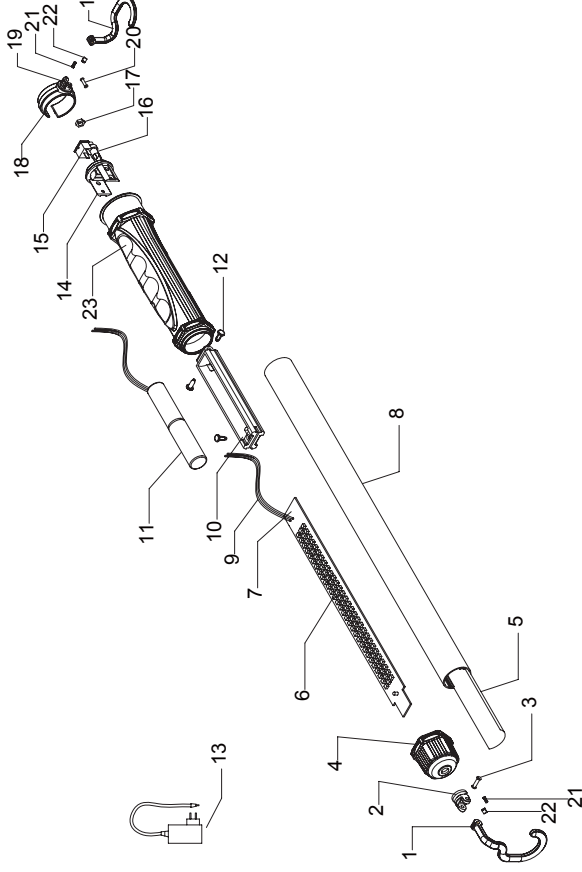

ITEM#	ORDERING PART#	PART DESCRIPTION
1	PRT80330-01	TOP HOOK ASSY (1, 2, 3, 21 & 22)
2	PRT80330-01	TOP HOOK ASSY (1, 2, 3, 21 & 22)
3	PRT80330-01	TOP HOOK ASSY (1, 2, 3, 21 & 22)
4	PRT80330-04	TOP CAP
5	PRT80390-05	LOGO PAPER
6	PRT80390-06-07	PCBA ASSY
7	PRT80390-06-07	PCBA ASSY
8	PRT80390-08	TUBE
9	PRT80390-09	WIRE
10	PRT80330-10	BATTERY COVER
11	PRT80330-11	LHON BATTERY
12	PRT80330-12	SCREW
13	PRT80330-13	CHARGER
14	PRT80330-14	SWITCH CONNECTOR
15	PRT80330-15	ON/OFF SWITCH
16	PRT80330-16	DC POWER INLET
17	PRT80330-17	NUT
18	PRT80330-18	END HOOK ASSY (18, 19, 20, 21 & 22)
19	PRT80330-18	END HOOK ASSY (18, 19, 20, 21 & 22)
20	PRT80330-18	END HOOK ASSY (18, 19, 20, 21 & 22)
21	N/A	PART OF HOOK ASSY
22	N/A	PART OF HOOK ASSY
23	PRT80330-23	HANDLE