

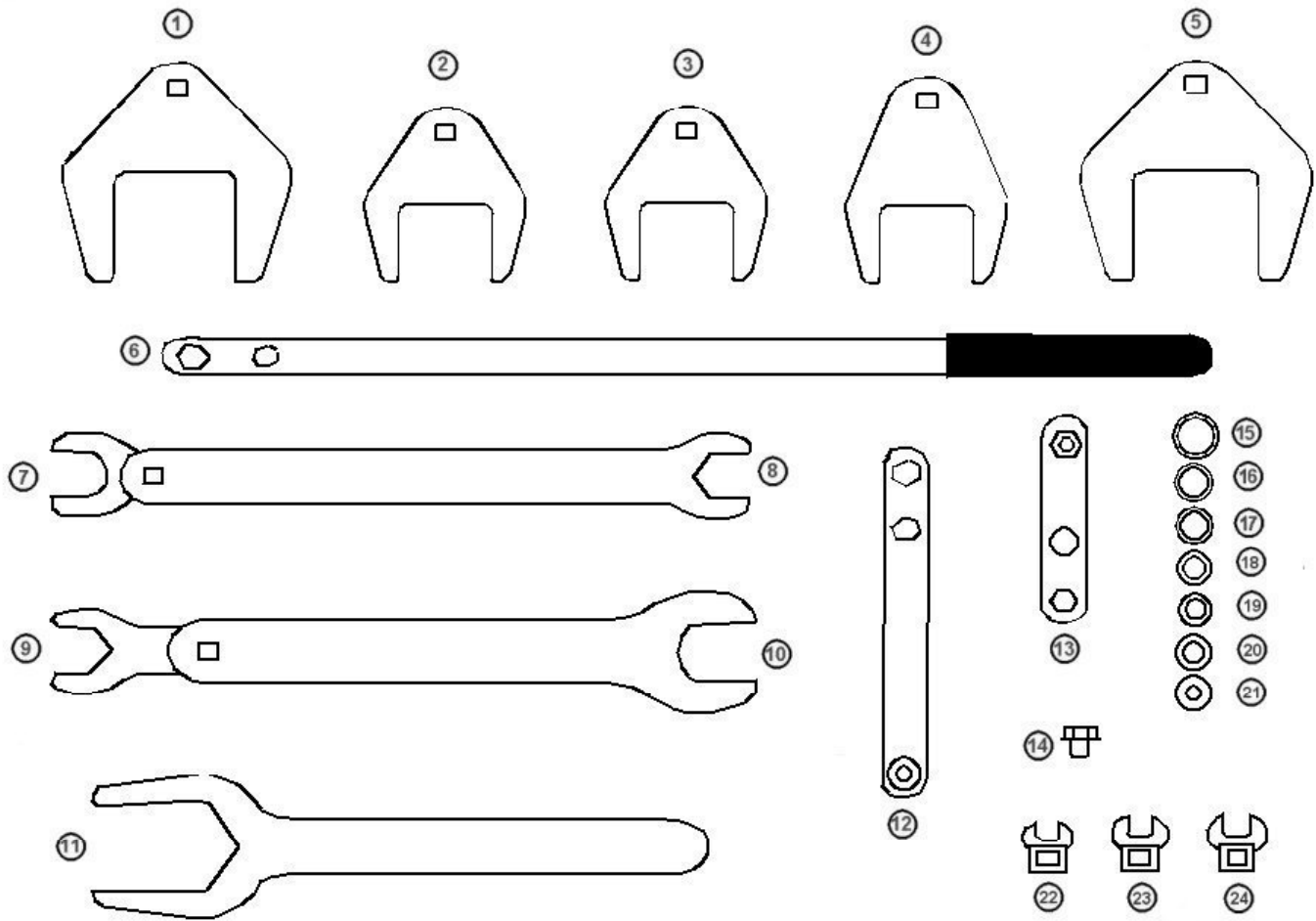

# ATD-8606



ORDERING PART#	ITEM#	PART DESCRIPTION
PRT8606-01	1	3-1/4" (82MM) FAN PULLEY HOLDING TOOL
PRT8606-02	2	2-1/4" (57MM) FAN PULLEY HOLDING TOOL
PRT8606-03	3	2-3/8" (60MM) FAN CLUTCH BOLT HOLDING TOOL
PRT8606-04	4	2-1/8" (54MM) FAN CLUTCH PULLEY HOLDING TOOL
PRT8606-05	5	3" (76MM) FAN CLUTCH PULLEY HOLDING TOOL
PRT8606-06	6	SERPENTINE BELT HOLDER (LENGTH: 590MM) - 13MM SOCKET- LATE MODEL GM QUAD FOUR ENGINE - 16MM SOCKET - 3.8 LITER FORD
PRT8606-07	7	1-7/16" (36MM) FAN CLUTCH WRENCH
PRT8606-08	8	1-7/16" (36MM) FAN CLUTCH NUT WRENCH
PRT8606-09	9	1-9/16" (39MM) FAN CLUTCH WRENCH
PRT8606-10	10	1-7/8" (47MM) LEFT HAND CLUTCH NUT WRENCH
PRT8606-11	11	2-13/16" (72MM) FAN HUB WRENCH
PRT8606-12	12	LONG EXTENSION - 15MM SOCKET- 3.3 LITER CHRYSLER - 16MM SOCKET - 3.8 LITER FORD

ORDERING PART#	ITEM#	PART DESCRIPTION
PRT8606-13	13	SHORT EXTENSION - 15MM SOCKET- 3.3 LITER CHRYSLER - 16MM SOCKET - 3.8 LITER FORD
PRT8606-14	14	3/8" BOLT - CONNECTS SERPENTINE BELT HOLDER TO EXTENSION.
PRT8606-15	15	18MM SOCKET - GM 3800 ENGINE
PRT8606-16	16	16MM SOCKET - 4.0 LITER FORD
PRT8606-17	17	15MM SOCKET - SOME GM AND CHRYSLER
PRT8606-18	18	14MM SOCKET - 1.9 LITER SATURN
PRT8606-19	19	13MM SOCKET - GM QUAD FOUR ENGINE
PRT8606-20	20	1/2" SQUARE DRIVE - LATE MODEL GM AND FORD
PRT8606-21	21	3/8" SQUARE DRIVE SOCKET - 3.1 LITER GM
PRT8606-22	22	13MM CROWFOOT - GM QUAD FOUR ENGINE
PRT8606-23	23	14MM CROWFOOT - SATURN ENGINE
PRT8606-24	24	15MM CROWFOOT - FORD WINDSTAR WITH 3.8 L ENGINE