

## OPERATING INSTRUCTIONS

**ATD-5590**  
**Low Current Probe/DMM**

**DC/AC CLAMP METER**

## **Safety**

### ***International Safety Symbols***



This symbol, adjacent to another symbol or terminal, indicates the user must refer to the manual for further information



This symbol, adjacent to a terminal, indicates that, under normal use, hazardous voltages may be present



Double insulation

## **SAFETY NOTES**

- Do not exceed the maximum allowable input range of any function
- Do not apply voltage to meter when resistance function is selected.
- Set the function switch OFF when the meter is not in use.

## **WARNINGS**

- Set function switch to the appropriate position before measuring.
- When measuring volts do not switch to current/resistance modes.
- Do not measure current on a circuit whose voltage exceeds 240V.
- When changing ranges using the selector switch always disconnect the test leads from the circuit under test.
- Do not exceed the maximum rated input limits.

# CAUTIONS

Improper use of this meter can cause damage, shock, injury or death. Read and understand this user manual before operating the meter.

Always remove the test leads before replacing the battery. Inspect the condition of the test leads and the meter itself for any damage before operating the meter. Repair or replace any damage before use.

Use great care when making measurements if the voltages are greater than 25VAC rms or 35VDC. These voltages are considered a shock hazard.

Remove the battery if the meter is to be stored for long periods.

Always discharge capacitors and remove power from the device under test before performing Diode, Resistance or Continuity tests.

- Voltage checks on electrical outlets can be difficult and misleading because of the uncertainty of connection to the recessed electrical contacts. Other means should be used to ensure that the terminals are not "live".
- If the equipment is used in a manner not specified by the manufacturer, the protection provided by the equipment may be impaired.

Input Limits	
Function	Maximum Input
A AC, A DC	80A
V DC, V AC	600V DC/AC
Resistance, Diode, Continuity, Frequency, Duty Cycle, Capacitance Test.	250V DC/AC

## Meter Description

1. Current clamp
2. Clamp trigger
3. Safety protection ring
4. ZERO button
5. Data Hold and Backlight button
6. Mode select button
7. Range select button
8. Hz/%duty button
9. Rotary Function switch
10. LCD display
11. COM input jack
12. V Ω Hz/% jack
13. Battery Cover

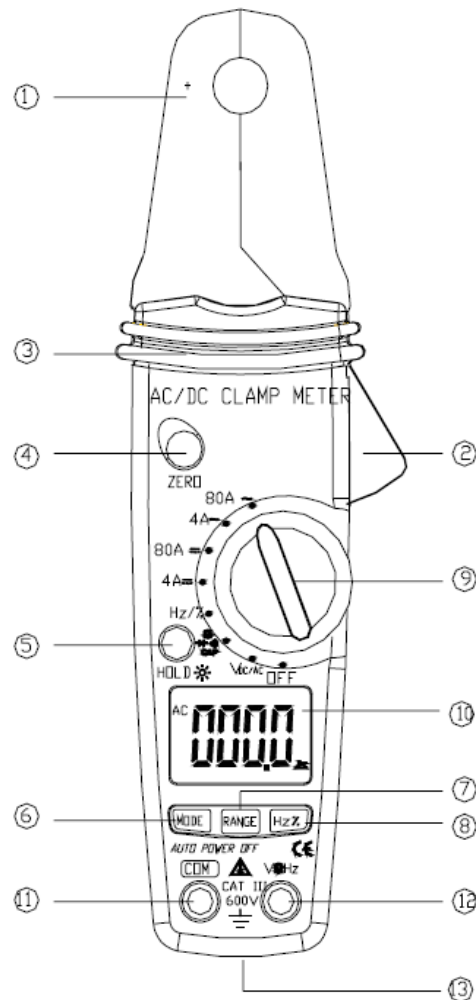

- |                          |  |
|--------------------------|--|
| <b>AC</b>                | AC (alternating current)                   |
| <b>DC</b>                | DC (direct current)                        |
| (-)                      | Minus sign                                 |
| 8.8.8.8                  | 4000 count (0 to 3999) measurement reading |
| <b>AUTO</b>              | Auto Range mode                            |
| <b>ZERO</b>              | ZERO mode                                  |
|                          | Diode test mode                            |
| •)))                     | Audible Continuity                         |
| <b>HOLD</b>              | Data Hold mode                             |
| °C, °F, m, V, A, K, M, Ω | Units of measure list                      |

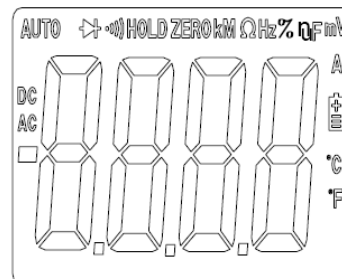

# SPECIFICATIONS

Function	Range & Resolution	Accuracy (% of reading)
DC Current	4.000 A DC	± (2.8% + 10 digits)
	80.0 A DC	± (3% + 8 digits)
AC Current (50/60Hz)	4.000 A AC	± (3.0% + 10 digits)
	80.0 A AC	± (3.0% + 8 digits)
DC Voltage	400.0 mV DC	± (1.0% + 15 digits)
	4.000 V DC	± (1.0% + 3 digits)
	40.00 V DC	± (1.5% + 3 digits)
	400.0 V DC	
	600 V DC	± (2.0% + 3 digits)
AC Voltage (50/60Hz)	400.0 mV AC	± (1.0% + 30 digits)
	4.000 V AC	± (2.0% + 5 digits)
	40.00 V AC	
	400.0 V AC	
	600 V AC	± (2.0% + 5 digits)
Resistance	400.0 Ω	± (1.0% + 4 digits)
	4.000 KΩ	± (1.5% + 2 digits)
	40.00 KΩ	
	400.0 KΩ	
	4.000 MΩ	± (2.5% + 3 digits)
40.00 MΩ	± (3.5% + 5 digits)	
Capacitance	40.00 nF	± (5.0% reading + 30 digits)
	400.0 nF	± (3.0% reading + 5 digits)
	4.000 μF	± (3.5% reading + 5 digits)
	40.00 μF	
	100.0 μF	± (5.0% reading + 5 digits)
Frequency	5.000 Hz	± (1.5% reading + 5 digits)
	50.00 Hz	± (1.2% reading + 2 digits)
	500.0 Hz	Sensitivity: 10Vrms min. @ 20% to 80% duty cycle
	5.000 kHz	
	50.00 kHz	
	500.0 kHz	
	5.000 MHz	
	10.00 MHz	
10.00 MHz		
Duty Cycle	0.5 to 99.0%	± (1.2% reading + 2 digits)
	Pulse width: 100 μs - 100 ms, Frequency: 5 Hz to 150 kHz; Sensitivity: 10Vrms min.	
Analog output: (for ACA & DCA range), 10mV/Amp (20KHz at ±3dB) Accuracy: ± ( 4.5% reading + 1mV ) Output impedance: approx 3KΩ		

<b>Clamp size</b>	Opening 0.5" (23mm) approx
<b>Diode Test</b>	Test current of 0.3mA typical; Open circuit voltage 1.5V DC typical.
<b>Continuity Check</b>	Threshold <150Ω; Test current< 1mA
<b>Low Battery Indication</b>	 is displayed
<b>Overrange Indication</b>	"OL" is displayed
<b>Measurements Rate</b>	2 per second, nominal
<b>Input Impedance</b>	7.8MΩ (VDC and VAC)
<b>Display</b>	4000 counts LCD
<b>Operating Temperature</b>	14° to 122°F (-10° to 50° C)
<b>Storage Temperature</b>	-22° to 140°F (-30° to 60°C)
<b>Relative Humidity</b>	90%(0°C to 30°C); 75%(30°C to 40°C); 45%(40°C to 50°C)
<b>Altitude Operating:</b>	3000m; Storage 10,000m
<b>Over voltage</b>	Category III 600V
<b>Battery</b>	Two 1.5V "AAA" Batteries
<b>Auto OFF</b>	approx. 25 minutes
<b>Dimensions/Weight</b>	200x50x35mm/200g
<b>Safety</b>	For indoor use and in accordance with Overvoltage Category II, Pollution Degree 2. Category II includes local level, appliance, portable equipment, etc., with transient overvoltages less than Overvoltage Cat. III

## Operation

**NOTICES:** Read and understand all **warning** and **precaution** statements listed in the safety section of this operation manual prior to using this meter. Set the function select switch to the OFF position when the meter is not in use.

### AC/DC Current Measurements

**WARNING:** Ensure that the test leads are disconnected from the meter before making current clamp measurements.

1. Set the Function switch to the **80ADC, 4ADC, 80AAC or 4AAC** range. If the range of the measured is not known, select the higher range first then move to the lower range if necessary.
2. Press the trigger to open jaw. Fully enclose one conductor wire to be measured.
3. If measuring **DCA**, press **ZERO** button to enter the zero reading.
4. The clamp meter LCD will display the reading.

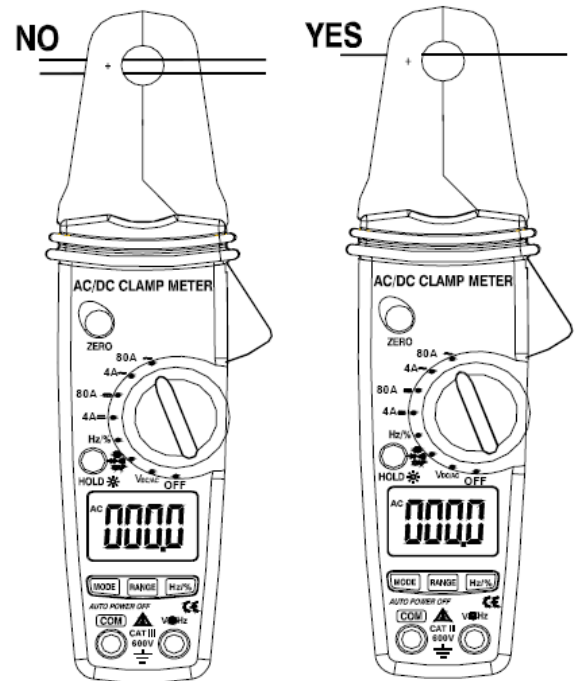





## Capacitance Measurements

**WARNING:** To avoid electric shock, disconnect power to the unit under test and discharge all capacitors before taking any capacitance measurements. Remove the batteries and unplug the line cords.

1. Set the rotary function switch to the cap position.
2. Insert the black test lead banana plug into the negative (COM) jack.  
Insert the red test lead banana plug into the positive (V) jack.
3. Touch the test leads to the capacitor to be tested.
4. Read the capacitance value in the display

## Frequency or % duty cycle measurements

1. Set the rotary function switch to the “Hz/%” position.
2. Insert the black lead banana plug into the negative COM jack and the red test lead banana plug into the positive V jack.
3. Select Hz or % duty with the **Hz/%** button.
4. Touch the test probe tips to the circuit under test.
5. Read the frequency on the display.

## Data Hold

To freeze the LCD meter reading, press the data hold button.

The data hold button is located on the left side of the meter (top button).

While data hold is active, the **HOLD** display icon appears on the LCD.

Press the data hold button again to return to normal operation.

Note: The HOLD feature will activate when the Backlight is turned on.

Press the HOLD key again to exit Hold.

## Backlight

Press and hold the HOLD key for >1 second to turn on or off the display backlight function.

**Note: The HOLD feature will activate when the Backlight is turned on. Press the HOLD key again to exit Hold.**

## ZERO BUTTON

For DCA and Capacitance Zero & Offset adjustment.

## Manual Ranging

The meter turns on in the autoranging mode. Press the **Range** button to go to manual ranging. Each press of the range button will step to the next range as indicated by the units and decimal point location. Press and hold the **Range** button for two seconds to return to autoranging. Manual ranging does not function in the AC Current , Diode and Continuity check functions

## Battery Replacement

1. Remove the one rear Phillips head screw
2. Open the battery compartment
3. Replace the Requires two “AAA” batteries (UM4 R03)
4. Re-assemble the meter

## Warranty Information

This product is warranted to be free from defects for one year. If this product fails during the first 12 months due to faulty materials or workmanship, it will be replaced free of charge, at the discretion of the manufacturer.

**NOTE:** This one year warranty does not cover dead batteries and blown fuses. For warranty and service coverage, please return this product to your dealer for processing and evaluation. OR, return it directly to:

Electronic Specialties, Inc.  
139 Elizabeth Ln.  
Genoa City, WI 53128  
262-279-1400  
[WWW.ESITEST.COM](http://WWW.ESITEST.COM)

Defective units being returned to your dealer or to the factory should include proof of purchase date. Any testers that do not function due to misuse or abuse will be subject to "out of warranty service charges."