

Set-Up Guide

GN9330e



Welcome to Microsoft Office Communicator!

Using this headset with Office Communicator will provide a simple, more consistent audio experience than using the microphone and speakers on your computer (if available). You can also use this headset to answer calls on your Deskphone.

Setup Instructions:

1. Connect the power cable to the base and to a power outlet.
2. Connect the USB cable to the base and to a USB port on your PC.
3. Connect the two halves of the headset together (A).
4. Connect the headset to the base and allow to fully charge. 4 green LED's on the front of the base will light up from left to right as the headset charges. The headset is fully charged when all 4 LED's are lit (B) (this will take about 3 hours).
5. Open Communicator 2007.
6. Click the drop down arrow on the upper left corner.
7. Select the Tools option.
8. Select "Set Up Audio and Video..."
9. On the first pane you will set the Handset or Headset you want to use. Make sure that **Headset (GN9330)** is selected in the drop down menu. Then click **Next**.
10. Make sure the Headset (GN9330) is listed as your speaker and microphone in the appropriate boxes. (See graphic at right) You may need to set the top drop down menu to Custom in order to change these settings. Then click **Next**.
11. On this pane, you will set the audio output location for your program sounds. It is recommended that you use your PC speakers for this setting if you have a sound card and speakers available.
12. When you have selected the output location, click the **Finish** button.

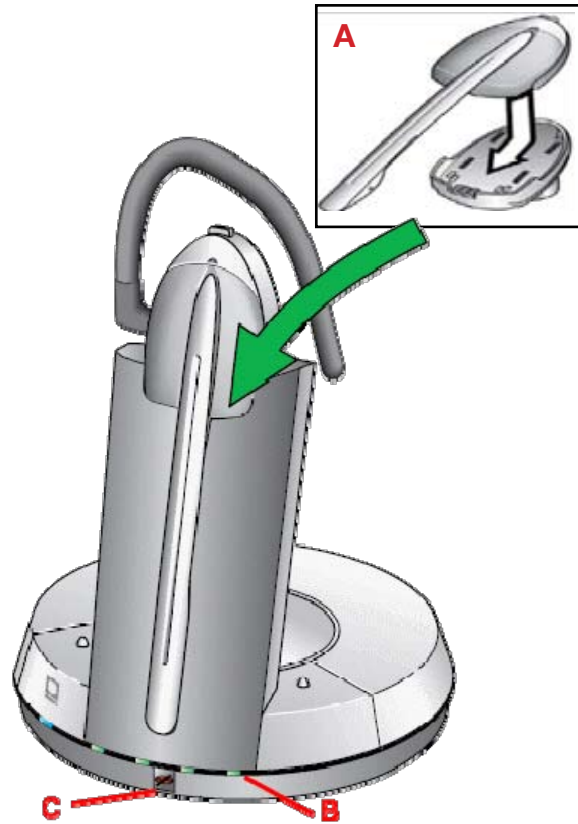

TIP: The GN9330's microphone can be muted by pressing in on the volume rocker on the headset. A red LED will be lit on the base while the microphone is muted (C).

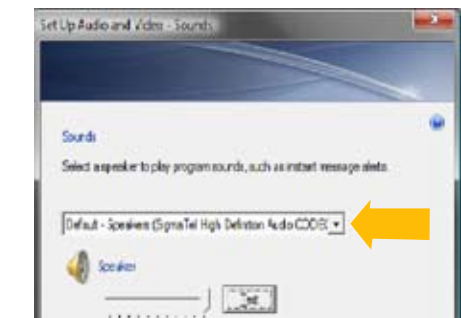
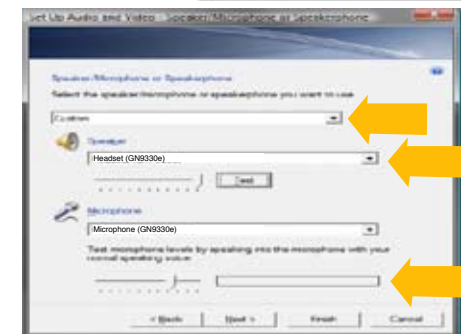
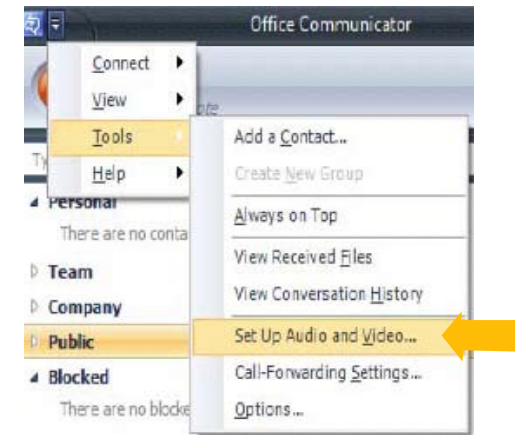

Set-Up Guide

GN9330e



To make a call with Office Communicator

One click calls:

1. Remove the headset from it from the base. It will automatically start an audio connection with your computer and you will hear dialtone. If you already have the headset off the base but don't have dialtone, press the answer/release button on the headset (**A**) or the one on the base (**B**). A blue LED will flash on the headset and on the base (**C**) when the headset is offhook.
2. Make one-click phone calls to contacts in your contact list by selecting their name and clicking the call button. A call window will pop up.
3. You can also call other numbers for a contact by clicking the calling options arrow to the right of the call button and choosing which number to call.

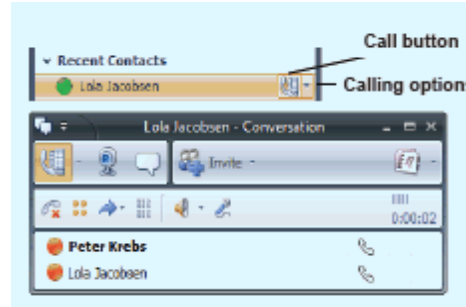
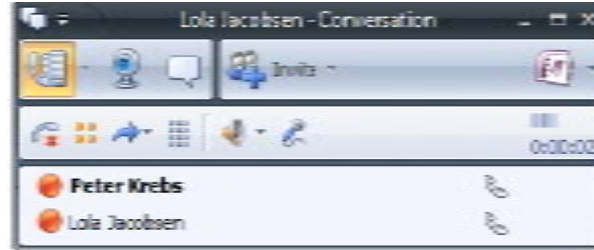

To receive a call with Office Communicator

1. You will see a call notification on your computer screen when you receive a telephone call.
2. If your headset is on base, remove it from the base and the call will automatically be picked up.
3. If you are wearing the headset, answer the call by either pressing the answer/release button on the headset (**A**) or the one on the base (**B**).
4. You can also answer the call by clicking on the call notification, but keep in mind that this will pick up the call on the speakerphone device you setup in the Setup Audio and Video wizard in Communicator.

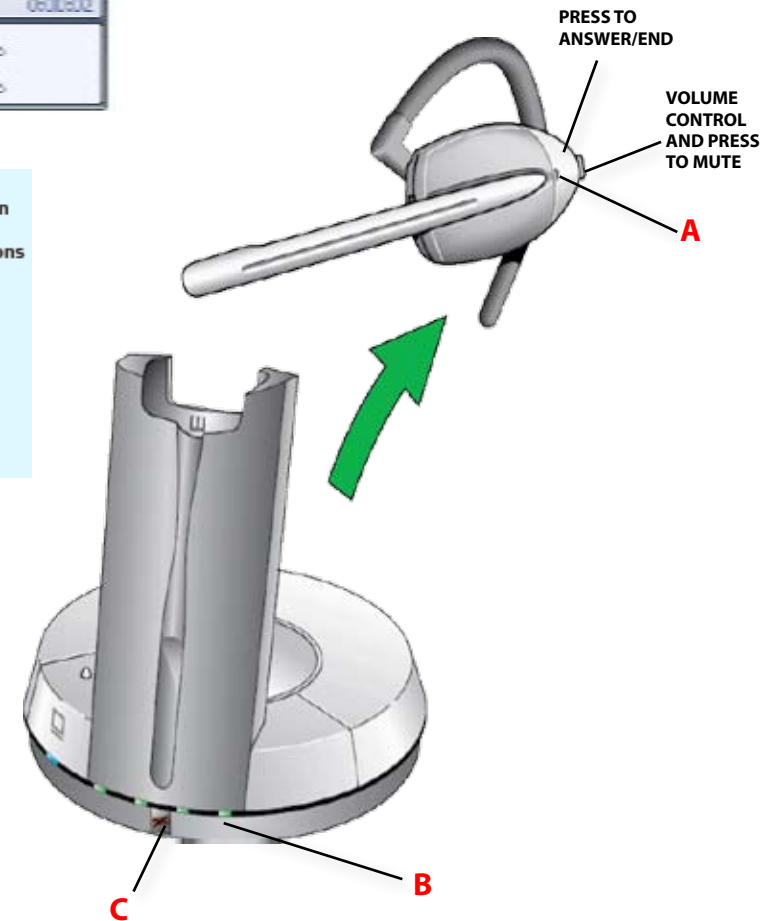
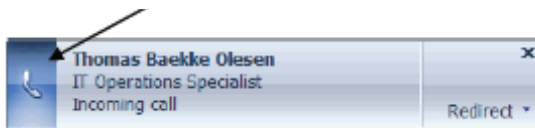

A BRAND BY



JABRA® IS A REGISTERED TRADEMARK OF GN NETCOM A/S
WWW.JABRA.COM