





OM-402B

April 1997

Eff. w/Serial Number KH383240

Processes

 Shielded Metal Arc (Stick) Welding

 Gas Tungsten Arc (TIG) Welding

With Optional Equipment:

 Flux Cored Arc Welding

Description



Engine Driven Welding Generator

Metro™ 250D



OWNER'S MANUAL



Visit our website at
www.MillerWelds.com

From Miller to You

Thank you and congratulations on choosing Miller. Now you can get the job done and get it done right. We know you don't have time to do it any other way.

That's why when Niels Miller first started building arc welders in 1929, he made sure his products offered long-lasting value and superior quality. Like you, his customers couldn't afford anything less. Miller products had to be more than the best they could be. They had to be the best you could buy.



Today, the people that build and sell Miller products continue the tradition. They're just as committed to providing equipment and service that meets the high standards of quality and value established in 1929.

This Owner's Manual is designed to help you get the most out of your Miller products. Please take time to read the Safety precautions. They will help you protect yourself against potential hazards on the worksite. We've

made installation and operation quick and easy. With Miller you can count on years of reliable service with proper maintenance. And if for some reason the unit needs repair, there's a Troubleshooting section that will help you figure out what the problem is. The parts list will then help you to decide which exact part you may need to fix the problem. Warranty and service information for your particular model are also provided.



Miller is the first welding equipment manufacturer in the U.S.A. to be registered to the ISO 9001 Quality System Standard.

Miller Electric manufactures a full line of welders and welding related equipment. For information on other quality Miller products, contact your local Miller distributor to receive the latest full line catalog or individual catalog sheets. **To locate your nearest distributor or service agency call 1-800-4-A-Miller, or visit us at www.MillerWelds.com on the web.**



Working as hard as you do – every power source from Miller is backed by the most hassle-free warranty in the business.

Miller offers a Technical Manual which provides more detailed service and parts information for your unit. To obtain a Technical Manual, contact your local distributor. Your distributor can also supply you with Welding Process Manuals such as SMAW, GTAW, GMAW, and GMAW-P.



Metro™ 250D

CALIFORNIA

Proposition 65 Warning

Diesel engine exhaust and some of its constituents are known to the State of California to cause cancer, birth defects, and other reproductive harm.

Call
1-800-4-A-MILLER
for your local
Miller distributor.

Your distributor gives you ...

Service

You always get the fast, reliable response you need. Most replacement parts can be in your hands in 24 hours.

Support

Need fast answers to the tough welding questions? Contact your distributor. The expertise of the distributor and Miller is there to help you, every step of the way.

Description



Multiple patented innovations put the new Metro™ 250D constant current welder/generator on the leading edge of engine-driven welding technology. Combining advanced design and outstanding DC stick and DC TIG characteristics, the Metro is an ideal machine for on-site work in construction, fabrication, repair, power generation, pipe welding, and rental markets as well.

Delivering 250 amps at 100% duty cycle (280 amps at 60%), the Metro has the muscle to handle tough assignments with the spare power needed for other equipment.

The Metro boasts an industrial, air-cooled, two-cylinder diesel engine that delivers 10 kVA/kW of auxiliary power and runs for at least 16 hours on one tank of fuel. The low noise case provides remarkably quiet operation, 99 LW(A) or 74 dB(A) at 23 ft (7 m), making the Metro 250D an excellent machine for work in noise-restricted locations.

Processes



Stick (SMAW) Welding



TIG (GTAW) Welding

With Optional Equipment:



Flux Cored (FCAW) Welding

The following terms are used interchangeably in this manual: TIG = GTAW, Stick = SMAW

Table of Contents

Section	Page
1. Safety Precautions	1
1. Consignes de sécurité	5
2. Definitions	9
3. Specifications	15
4. Installation	17
5. Operating the Welding Generator	21
6. Operating Auxiliary Equipment	23
7. Maintenance & Troubleshooting	24
8. Electrical Diagram	34
9. Run-In Procedure	36
10. Auxiliary Power Guidelines	39
11. Parts List	46

Options and Accessories

Warranty

Features

- NEW! Warranty extended to 3 years (engine warranted by engine manufacturer)
- Versatile weld output for DC Stick and DC TIG welding
- Stepless amperage control for precise heat selection
- Arc force control ensures a forceful arc for tight fit-ups – prevents electrode sticking
- Built-in Hot Start circuit for dependable arc starting
- Remote control receptacle permits remote current and contactor control
- Panel includes hour meter and fuel gauge
- Earth leakage protection for auxiliary power receptacles
- Product features and specifications are subject to change without notice

Engine

- Deutz/Ruggerini RD 211 twin-cylinder diesel engine, 23 HP at 3600 RPM
- Air cooling eliminates radiators, belts, thermostats, coolant hoses, and antifreeze required in liquid-cooled engines
- Automatic idle for fuel economy and reduced noise
- Automatic shutdown system protects against low oil pressure
- Large 12 gallon (45 L) fuel capacity
- Two-year North American warranty from engine manufacturer

Miller offers a Technical Manual which provides more detailed service and parts information for your unit. To obtain a Technical Manual, contact your local distributor. Your distributor can also supply you with Welding Process Manuals such as SMAW, GTAW, GMAW, and GMAW-P.

For practical information on welding, process applications, and Miller products, visit our website at

www.millerwelds.com

1. Safety Precautions – Read Before Using

1.1 Symbol Usage

OM-402B -4/97, safety_rom 4/97



Means Warning! Watch Out! There are possible hazards with this procedure! The possible hazards are shown in the adjoining symbols.

▲ Marks a special safety message.

☞ Means "Note"; not safety related.



This group of symbols means Warning! Watch Out! possible ELECTRIC SHOCK, MOVING PARTS, and HOT PARTS hazards. Consult symbols and related instructions below for necessary actions to avoid the hazards.

1.2 Arc Welding Hazards

▲ The symbols shown below are used throughout this manual to call attention to and identify possible hazards. When you see the symbol, watch out, and follow the related instructions to avoid the hazard. The safety information given below is only a summary of the more complete safety information found in the Safety Standards listed in Section 1.5. Read and follow all Safety Standards.

▲ Only qualified persons should install, operate, maintain, and repair this unit.

▲ During operation, keep everybody, especially children, away.



ELECTRIC SHOCK can kill.

Touching live electrical parts can cause fatal shocks or severe burns. The electrode and work circuit is electrically live whenever the output is on. The input power circuit and machine internal circuits are also

live when power is on. In semiautomatic or automatic wire welding, the wire, wire reel, drive roll housing, and all metal parts touching the welding wire are electrically live. Incorrectly installed or improperly grounded equipment is a hazard.

- Do not touch live electrical parts.
- Wear dry, hole-free insulating gloves and body protection.
- Insulate yourself from work and ground using dry insulating mats or covers big enough to prevent any physical contact with the work or ground.
- Do not use AC output in damp areas, if movement is confined, or if there is a danger of falling.
- Use AC output ONLY if required for the welding process.
- If AC output is required, use remote output control if present on unit.
- Disconnect input power or stop engine before installing or servicing this equipment. Lockout/tagout input power according to OSHA 29 CFR 1910.147 (see Safety Standards).
- Properly install and ground this equipment according to its Owner's Manual and national, state, and local codes.
- Always verify the supply ground – check and be sure that input power cord ground wire is properly connected to ground terminal in disconnect box or that cord plug is connected to a properly grounded receptacle outlet.
- When making input connections, attach proper grounding conductor first – double-check connections.
- Frequently inspect input power cord for damage or bare wiring – replace cord immediately if damaged – bare wiring can kill.
- Turn off all equipment when not in use.
- Do not use worn, damaged, undersized, or poorly spliced cables.
- Do not drape cables over your body.
- If earth grounding of the workpiece is required, ground it directly with a separate cable – do not use work clamp or work cable.

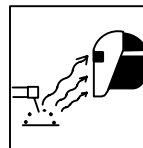

ARC RAYS can burn eyes and skin.

Arc rays from the welding process produce intense visible and invisible (ultraviolet and infrared) rays that can burn eyes and skin. Sparks fly off from the weld.

- Wear a welding helmet fitted with a proper shade of filter to protect your face and eyes from arc rays and sparks when welding or watching (see ANSI Z49.1 and Z87.1 listed in Safety Standards).
- Wear approved safety glasses with side shields under your helmet.
- Use protective screens or barriers to protect others from flash and glare; warn others not to watch the arc.
- Wear protective clothing made from durable, flame-resistant material (wool and leather) and foot protection.

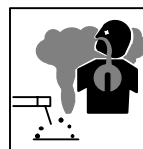

FUMES AND GASES can be hazardous.

Welding produces fumes and gases. Breathing these fumes and gases can be hazardous to your health.

- Keep your head out of the fumes. Do not breathe the fumes.
- If inside, ventilate the area and/or use exhaust at the arc to remove welding fumes and gases.
- If ventilation is poor, use an approved air-supplied respirator.
- Read the Material Safety Data Sheets (MSDSs) and the manufacturer's instructions for metals, consumables, coatings, cleaners, and degreasers.
- Work in a confined space only if it is well ventilated, or while wearing an air-supplied respirator. Always have a trained watch-person nearby. Welding fumes and gases can displace air and lower the oxygen level causing injury or death. Be sure the breathing air is safe.
- Do not weld in locations near degreasing, cleaning, or spraying operations. The heat and rays of the arc can react with vapors to form highly toxic and irritating gases.
- Do not weld on coated metals, such as galvanized, lead, or cadmium plated steel, unless the coating is removed from the weld area, the area is well ventilated, and if necessary, while wearing an air-supplied respirator. The coatings and any metals containing these elements can give off toxic fumes if welded.



WELDING can cause fire or explosion.

Welding on closed containers, such as tanks, drums, or pipes, can cause them to blow up. Sparks can fly off from the welding arc. The flying sparks, hot workpiece, and hot equipment can cause fires and burns. Accidental contact of electrode to metal objects can cause sparks, explosion, overheating, or fire. Check and be sure the area is safe before doing any welding.

- Protect yourself and others from flying sparks and hot metal.
- Do not weld where flying sparks can strike flammable material.
- Remove all flammables within 35 ft (10.7 m) of the welding arc. If this is not possible, tightly cover them with approved covers.
- Be alert that welding sparks and hot materials from welding can easily go through small cracks and openings to adjacent areas.
- Watch for fire, and keep a fire extinguisher nearby.
- Be aware that welding on a ceiling, floor, bulkhead, or partition can cause fire on the hidden side.
- Do not weld on closed containers such as tanks, drums, or pipes, unless they are properly prepared according to AWS F4.1 (see Safety Standards).
- Connect work cable to the work as close to the welding area as practical to prevent welding current from traveling long, possibly unknown paths and causing electric shock and fire hazards.
- Do not use welder to thaw frozen pipes.
- Remove stick electrode from holder or cut off welding wire at contact tip when not in use.
- Wear oil-free protective garments such as leather gloves, heavy shirt, cuffless trousers, high shoes, and a cap.
- Remove any combustibles, such as a butane lighter or matches, from your person before doing any welding.

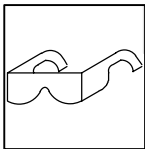

FLYING METAL can injure eyes.

- Welding, chipping, wire brushing, and grinding cause sparks and flying metal. As welds cool, they can throw off slag.
- Wear approved safety glasses with side shields even under your welding helmet.



BUILDUP OF GAS can injure or kill.

- Shut off shielding gas supply when not in use.
- Always ventilate confined spaces or use approved air-supplied respirator.

1.3 Engine Hazards



FUEL can cause fire or explosion.

- Stop engine and let it cool off before checking or adding fuel.
- Do not add fuel while smoking or if unit is near any sparks or open flames.
- Do not overfill tank – allow room for fuel to expand.
- Do not spill fuel. If fuel is spilled, clean up before starting engine.
- Dispose of rags in a fireproof container.



HOT PARTS can cause severe burns.

- Allow cooling period before maintaining.
- Wear protective gloves and clothing when working on a hot engine.
- Do not touch hot engine parts or just-welded parts bare-handed.

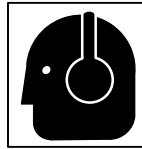

NOISE can damage hearing.

Noise from some processes or equipment can damage hearing.

- Wear approved ear protection if noise level is high.

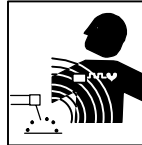

MAGNETIC FIELDS can affect pacemakers.

- Pacemaker wearers keep away.
- Wearers should consult their doctor before going near arc welding, gouging, or spot welding operations.

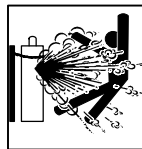

CYLINDERS can explode if damaged.

Shielding gas cylinders contain gas under high pressure. If damaged, a cylinder can explode. Since gas cylinders are normally part of the welding process, be sure to treat them carefully.

- Protect compressed gas cylinders from excessive heat, mechanical shocks, slag, open flames, sparks, and arcs.
- Install cylinders in an upright position by securing to a stationary support or cylinder rack to prevent falling or tipping.
- Keep cylinders away from any welding or other electrical circuits.
- Never drape a welding torch over a gas cylinder.
- Never allow a welding electrode to touch any cylinder.
- Never weld on a pressurized cylinder – explosion will result.
- Use only correct shielding gas cylinders, regulators, hoses, and fittings designed for the specific application; maintain them and associated parts in good condition.
- Turn face away from valve outlet when opening cylinder valve.
- Keep protective cap in place over valve except when cylinder is in use or connected for use.
- Read and follow instructions on compressed gas cylinders, associated equipment, and CGA publication P-1 listed in Safety Standards.

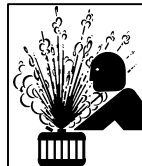

STEAM AND HOT COOLANT can burn.

- If possible, check coolant level when engine is cold to avoid scalding.
- If the engine is warm and checking is needed, follow the next two statements.
- Wear safety glasses and gloves and put a rag over radiator cap.
- Turn cap slightly and let pressure escape slowly before completely removing cap.



MOVING PARTS can cause injury.

- Keep away from fans, belts, and rotors.
- Keep all doors, panels, covers, and guards closed and securely in place.
- Stop engine before installing or connecting unit.
- Have only qualified people remove guards or covers for maintenance and troubleshooting as necessary.
- To prevent accidental starting during servicing, disconnect negative (-) battery cable from battery.
- Keep hands, hair, loose clothing, and tools away from moving parts.
- Reinstall panels or guards and close doors when servicing is finished and before starting engine.
- Before working on generator, remove spark plugs or injectors to keep engine from kicking back or starting.
- Block flywheel so that it will not turn while working on generator components.

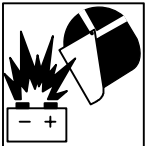

BATTERY EXPLOSION can BLIND.

- Always wear a face shield, rubber gloves, and protective clothing when working on a battery.
- Stop engine before disconnecting or connecting battery cables or servicing battery.
- Do not allow tools to cause sparks when working on a battery.
- Do not use welder to charge batteries or jump start vehicles.
- Observe correct polarity (+ and -) on batteries.
- Disconnect negative (-) cable first and connect it last.

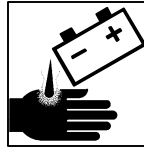

BATTERY ACID can BURN SKIN and EYES.

- Do not tip battery.
- Replace damaged battery.
- Flush eyes and skin immediately with water.

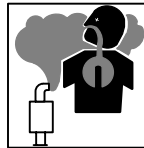

ENGINE EXHAUST GASES can kill.

- Use equipment outside in open, well-ventilated areas.
- If used in a closed area, vent engine exhaust outside and away from any building air intakes.



ENGINE HEAT can cause fire.

- Do not locate unit on, over, or near combustible surfaces or flammables.
- Keep exhaust and exhaust pipes way from flammables.



EXHAUST SPARKS can cause fire.

- Do not let engine exhaust sparks cause fire.
- Use approved engine exhaust spark arrestor in required areas – see applicable codes.

1.4 Additional Symbols for Installation, Operation, and Maintenance



FALLING UNIT can cause injury.

- Use lifting eye to lift unit only, NOT running gear, gas cylinders, trailer, or any other accessories.
- Use equipment of adequate capacity to lift and support unit.
- If using lift forks to move unit, be sure forks are long enough to extend beyond opposite side of unit.

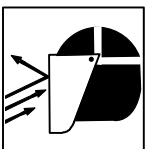

FLYING SPARKS can cause injury.

- Wear a face shield to protect eyes and face.
- Shape tungsten electrode only on grinder with proper guards in a safe location wearing proper face, hand, and body protection.
- Sparks can cause fires — keep flammables away.

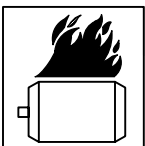

OVERHEATING can damage motors.

- Turn off or unplug equipment before starting or stopping engine.
- Do not let low voltage and frequency caused by low engine speed damage electric motors.
- Do not connect 50 or 60 Hertz motors to the 100 Hertz receptacle where applicable.

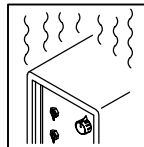

OVERUSE can cause OVERHEATING.

- Allow cooling period; follow rated duty cycle.
- Reduce current or reduce duty cycle before starting to weld again.
- Do not block or filter airflow to unit.

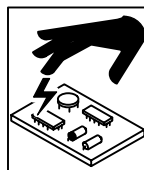

STATIC (ESD) can damage PC boards.

- Put on grounded wrist strap BEFORE handling boards or parts.
- Use proper static-proof bags and boxes to store, move, or ship PC boards.



TILTING OF TRAILER can cause injury.

- Use tongue jack or blocks to support weight.
- Properly install welding generator onto trailer according to instructions supplied with trailer.

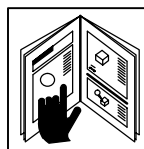

READ INSTRUCTIONS.

- Use only genuine MILLER replacement parts.
- Perform engine maintenance and service according to this manual and the engine manual.

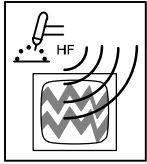

H.F. RADIATION can cause interference.

- High-frequency (H.F.) can interfere with radio navigation, safety services, computers, and communications equipment.
- Have only qualified persons familiar with electronic equipment perform this installation.
- The user is responsible for having a qualified electrician promptly correct any interference problem resulting from the installation.
- If notified by the FCC about interference, stop using the equipment at once.
- Have the installation regularly checked and maintained.
- Keep high-frequency source doors and panels tightly shut, keep spark gaps at correct setting, and use grounding and shielding to minimize the possibility of interference.

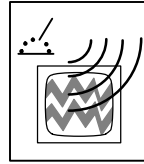

ARC WELDING can cause interference.

- Electromagnetic energy can interfere with sensitive electronic equipment such as computers and computer-driven equipment such as robots.
- Be sure all equipment in the welding area is electromagnetically compatible.
- To reduce possible interference, keep weld cables as short as possible, close together, and down low, such as on the floor.
- Locate welding operation 100 meters from any sensitive electronic equipment.
- Be sure this welding machine is installed and grounded according to this manual.
- If interference still occurs, the user must take extra measures such as moving the welding machine, using shielded cables, using line filters, or shielding the work area.

1.5 Principal Safety Standards

Safety in Welding and Cutting, ANSI Standard Z49.1, from American Welding Society, 550 N.W. LeJeune Rd, Miami FL 33126

Safety and Health Standards, OSHA 29 CFR 1910, from Superintendent of Documents, U.S. Government Printing Office, Washington, D.C. 20402.

Recommended Safe Practices for the Preparation for Welding and Cutting of Containers That Have Held Hazardous Substances, American Welding Society Standard AWS F4.1, from American Welding Society, 550 N.W. LeJeune Rd, Miami, FL 33126

National Electrical Code, NFPA Standard 70, from National Fire Protection Association, Batterymarch Park, Quincy, MA 02269.

Safe Handling of Compressed Gases in Cylinders, CGA Pamphlet P-1, from Compressed Gas Association, 1235 Jefferson Davis Highway, Suite 501, Arlington, VA 22202.

Code for Safety in Welding and Cutting, CSA Standard W117.2, from Canadian Standards Association, Standards Sales, 178 Rexdale Boulevard, Rexdale, Ontario, Canada M9W 1R3.

Safe Practices For Occupation And Educational Eye And Face Protection, ANSI Standard Z87.1, from American National Standards Institute, 1430 Broadway, New York, NY 10018.

Cutting And Welding Processes, NFPA Standard 51B, from National Fire Protection Association, Batterymarch Park, Quincy, MA 02269.

1.6 EMF Information

Considerations About Welding And The Effects Of Low Frequency Electric And Magnetic Fields

The following is a quotation from the General Conclusions Section of the U.S. Congress, Office of Technology Assessment, *Biological Effects of Power Frequency Electric & Magnetic Fields – Background Paper*, OTA-BP-E-53 (Washington, DC: U.S. Government Printing Office, May 1989): “. . . there is now a very large volume of scientific findings based on experiments at the cellular level and from studies with animals and people which clearly establish that low frequency magnetic fields can interact with, and produce changes in, biological systems. While most of this work is of very high quality, the results are complex. Current scientific understanding does not yet allow us to interpret the evidence in a single coherent framework. Even more frustrating, it does not yet allow us to draw definite conclusions about questions of possible risk or to offer clear science-based advice on strategies to minimize or avoid potential risks.”

To reduce magnetic fields in the workplace, use the following procedures:

1. Keep cables close together by twisting or taping them.
2. Arrange cables to one side and away from the operator.
3. Do not coil or drape cables around the body.
4. Keep welding power source and cables as far away from operator as practical.
5. Connect work clamp to workpiece as close to the weld as possible.

About Pacemakers:

Pacemaker wearers consult your doctor first. If cleared by your doctor, then following the above procedures is recommended.

1. Consignes de sécurité – lire avant utilisation

1.1 Signification des symboles

OM-402B - 4/97, safety_rom_fre 4/97



Signifie Mise en garde ! Soyez vigilant ! Cette procédure présente des risques de danger ! Ceux-ci sont identifiés par des symboles adjacents aux directives.

▲ Identifie un message de sécurité particulier.

Signifie NOTA ; n'est pas relatif à la sécurité.



Ce groupe de symboles signifie Mise en garde ! Soyez vigilant ! Il y a des risques de danger reliés aux CHOCS ÉLECTRIQUES, aux PIÈCES EN MOUVEMENT et aux PIÈCES CHAUDES. Reportez-vous aux symboles et aux directives ci-dessous afin de connaître les mesures à prendre pour éviter tout danger.

1.2 Dangers relatifs au soudage à l'arc

▲ Les symboles présentés ci-après sont utilisés tout au long du présent manuel pour attirer votre attention et identifier les risques de danger. Lorsque vous voyez un symbole, soyez vigilant et suivez les directives mentionnées afin d'éviter tout danger. Les consignes de sécurité présentées ci-après ne font que résumer l'information contenue dans les normes de sécurité énumérées à la section 1-5. Veuillez lire et respecter toutes ces normes de sécurité.

▲ L'installation, l'utilisation, l'entretien et les réparations ne doivent être confiés qu'à des personnes qualifiées.

▲ Au cours de l'utilisation, tenir toute personne à l'écart et plus particulièrement les enfants.



UN CHOC ÉLECTRIQUE peut tuer.

Un simple contact avec des pièces électriques peut provoquer une électrocution ou des blessures graves. L'électrode et le circuit de soudage sont sous tension dès que l'appareil est sur ON. Le circuit d'entrée et les circuits internes de l'appareil sont également sous tension à ce moment-là. En soudage semi-automatique ou automatique, le fil, le dévidoir, le logement des galets d'entraînement et les pièces métalliques en contact avec le fil de soudage sont sous tension. Des matériels mal installés ou mal mis à la terre présentent un danger.

- Ne jamais toucher les pièces électriques sous tension.
- Porter des gants et des vêtements de protection secs ne comportant pas de trous.
- S'isoler de la pièce et de la terre au moyen de tapis ou d'autres moyens isolants suffisamment grands pour empêcher le contact physique éventuel avec la pièce ou la terre.
- Ne pas se servir de source électrique à courant électrique dans les zones humides, dans les endroits confinés ou là où on risque de tomber.
- Se servir d'une source électrique à courant électrique UNIQUEMENT si le procédé de soudage le demande.
- Si l'utilisation d'une source électrique à courant électrique s'avère nécessaire, se servir de la fonction de télécommande si l'appareil en est équipé.
- Couper l'alimentation ou arrêter le moteur avant de procéder à l'installation, à la réparation ou à l'entretien de l'appareil. Déverrouiller l'alimentation selon la norme OSHA 29 CFR 1910.147 (voir normes de sécurité).
- Installer et mettre à la terre correctement cet appareil conformément à son manuel d'utilisation et aux codes nationaux, provinciaux et municipaux.
- Toujours vérifier la terre du cordon d'alimentation – Vérifier et s'assurer que le fil de terre du cordon d'alimentation est bien raccordé à la borne de terre du sectionneur ou que la fiche du cordon est raccordée à une prise correctement mise à la terre.
- En effectuant les raccordements d'entrée fixer d'abord le conducteur de mise à la terre approprié et contre-vérifier les connexions.
- Vérifier fréquemment le cordon d'alimentation pour voir s'il n'est pas endommagé ou dénudé – remplacer le cordon immédiatement s'il est endommagé – un câble dénudé peut provoquer une électrocution.
- Mettre l'appareil hors tension quand on ne l'utilise pas.
- Ne pas utiliser des câbles usés, endommagés, de grosseur insuffisante ou mal épissés.
- Ne pas enrouler les câbles autour du corps.
- Si la pièce soudée doit être mise à la terre, le faire directement avec un câble distinct – ne pas utiliser le connecteur de pièce ou le câble de retour.
- Ne pas toucher l'électrode quand on est en contact avec la pièce, la terre ou une électrode provenant d'une autre machine.

- N'utiliser qu'un matériel en bon état. Réparer ou remplacer sur-le-champ les pièces endommagées. Entretien l'appareil conformément à ce manuel.
- Porter un harnais de sécurité quand on travaille en hauteur.
- Maintenir solidement en place tous les panneaux et capots.
- Fixer le câble de retour de façon à obtenir un bon contact métal-métal avec la pièce à souder ou la table de travail, le plus près possible de la soudure.
- Isoler la pince de masse quand pas mis à la pièce pour éviter le contact avec tout objet métallique.

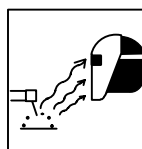

LES RAYONS DE L'ARC peuvent provoquer des brûlures dans les yeux et sur la peau.

Le rayonnement de l'arc du procédé de soudage génère des rayons visibles et invisibles intenses (ultraviolets et infrarouges) susceptibles de provoquer des brûlures dans les yeux et sur la peau. Des étincelles sont projetées pendant le soudage.

- Porter un casque de soudage muni d'un écran de filtre approprié pour protéger votre visage et vos yeux pendant le soudage ou pour regarder (voir ANSI Z49.1 et Z87.1 énuméré dans les normes de sécurité).
- Porter des protections approuvés pour les oreilles si le niveau sonore est trop élevé.
- Utiliser des écrans ou des barrières pour protéger des tiers de l'éclair et de l'éblouissement; demander aux autres personnes de ne pas regarder l'arc.
- Porter des vêtements de protection constitué dans une matière durable, résistant au feu (laine ou cuir) et une protection des pieds.

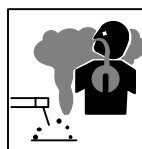

LES FUMÉES ET LES GAZ peuvent être dangereux.

Le soudage génère des fumées et des gaz. Leur inhalation peut être dangereuse pour votre santé.

- Eloigner votre tête des fumées. Ne pas respirer les fumées.
- À l'intérieur, ventiler la zone et/ou utiliser un échappement au niveau de l'arc pour l'évacuation des fumées et des gaz de soudage.
- Si la ventilation est insuffisante, utiliser un respirateur à alimentation d'air homologué.
- Lire les spécifications de sécurité des matériaux (MSDSs) et les instructions du fabricant concernant les métaux, les consommables, les revêtements, les nettoyants et les dégraisseurs.
- Travailler dans un espace fermé seulement s'il est bien ventilé ou en portant un respirateur à alimentation d'air. Demander toujours à un surveillant dûment formé de se tenir à proximité. Des fumées et des gaz de soudage peuvent déplacer l'air et abaisser le niveau d'oxygène provoquant des blessures ou des accidents mortels. S'assurer que l'air de respiration ne présente aucun danger.
- Ne pas souder dans des endroits situés à proximité d'opérations de dégraissage, de nettoyage ou de pulvérisation. La chaleur et les rayons de l'arc peuvent réagir en présence de vapeurs et former des gaz hautement toxiques et irritants.
- Ne pas souder des métaux munis d'un revêtement, tels que l'acier galvanisé, plaqué en plomb ou au cadmium à moins que le revêtement n'ait été enlevé dans la zone de soudure, que l'endroit soit bien ventilé, et si nécessaire, en portant un respirateur à alimentation d'air. Les revêtements et tous les métaux renfermant ces éléments peuvent dégager des fumées toxiques en cas de soudage.



LE SOUDAGE peut provoquer un incendie ou une explosion.

Le soudage effectué sur des conteneurs fermés tels que des réservoirs, tambours ou des conduites peut provoquer leur éclatement. Des étincelles peuvent être projetées de l'arc de soudure. La projection d'étincelles, des pièces chaudes et des équipements chauds peut provoquer des incendies et des brûlures. Le contact accidentel de l'électrode avec des objets métalliques peut provoquer des étincelles, une explosion, un surchauffement ou un incendie. Avant de commencer le soudage, vérifier et s'assurer que l'endroit ne présente pas de danger.

- Se protéger et d'autres personnes de la projection d'étincelles et de métal chaud.
- Ne pas souder dans un endroit où des étincelles peuvent tomber sur des substances inflammables.
- Déplacer toutes les substances inflammables à une distance de 10,7 m de l'arc de soudage. En cas d'impossibilité les recouvrir soigneusement avec des protections homologuées.
- Des étincelles et des matériaux chauds du soudage peuvent facilement passer dans d'autres zones en traversant de petites fissures et des ouvertures.
- Surveiller tout déclenchement d'incendie et tenir un extincteur à proximité.
- Le soudage effectué sur un plafond, plancher, paroi ou séparation peut déclencher un incendie de l'autre côté.
- Ne pas effectuer le soudage sur des conteneurs fermés tels que des réservoirs, tambours, ou conduites, à moins qu'ils n'aient été préparés correctement conformément à AWS F4.1 (voir les normes de sécurité).
- Brancher le câble sur la pièce le plus près possible de la zone de soudage pour éviter le transport du courant sur une longue distance par des chemins inconnus éventuels en provoquant des risques d'électrocution et d'incendie.
- Ne pas utiliser le poste de soudage pour dégeler des conduites gelées.
- En cas de non utilisation, enlever la baguette d'électrode du porte-électrode ou couper le fil à la pointe de contact.
- Porter des vêtements de protection dépourvus d'huile tels que des gants en cuir, une chemise en matériau lourd, des pantalons sans revers, des chaussures hautes et un couvre chef.
- Avant de souder, retirer toute substance combustible de vos poches telles qu'un allumeur au butane ou des allumettes.

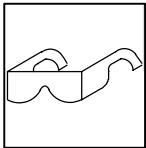

DES PARTICULES VOLANTES peuvent blesser les yeux.

- Le soudage, l'écaillage, le passage de la pièce à la brosse en fil de fer, et le meulage génèrent des étincelles et des particules métalliques volantes. Pendant la période de refroidissement des soudures, elles risquent de projeter du laitier.
 - Porter des lunettes de sécurité avec écrans latéraux ou un écran facial.



LES ACCUMULATIONS DE GAZ risquent de provoquer des blessures ou même la mort.

- Fermer l'alimentation du gaz protecteur en cas de non utilisation.
 - Veiller toujours à bien aérer les espaces confinés ou se servir d'un respirateur d'adduction d'air homologué.



DES PIÈCES CHAUDES peuvent provoquer des brûlures graves.

- Prévoir une période de refroidissement avant d'effectuer des travaux d'entretien.
- Porter des gants et des vêtements de protection pour travailler sur un moteur chaud.
 - Ne pas toucher à mains nues les parties chaudes du moteur ni les pièces récemment soudées.

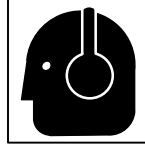

LE BRUIT peut affecter l'ouïe.

Le bruit des processus et des équipements peut affecter l'ouïe.

- Porter des protections approuvées pour les oreilles si le niveau sonore est trop élevé.

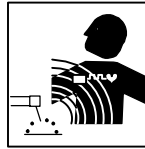

LES CHAMPS MAGNÉTIQUES peuvent affecter les stimulateurs cardiaques.

- Porteurs de stimulateur cardiaque, restez à distance.
- Les porteurs d'un stimulateur cardiaque doivent d'abord consulter leur médecin avant de s'approcher des opérations de soudage à l'arc, de gougeage ou de soudage par points.

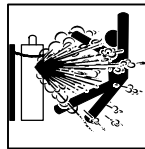

Si des BOUTEILLES sont endommagées, elles pourront exploser.

Des bouteilles de gaz protecteur contiennent du gaz sous haute pression. Si une bouteille est endommagée, elle peut exploser. Du fait que les bouteilles de gaz font normalement partie du procédé de soudage, les manipuler avec précaution.

- Protéger les bouteilles de gaz comprimé d'une chaleur excessive, des chocs mécaniques, du laitier, des flammes ouvertes, des étincelles et des arcs.
- Placer les bouteilles debout en les fixant dans un support stationnaire ou dans un porte-bouteilles pour les empêcher de tomber ou de se renverser.
- Tenir les bouteilles éloignées des circuits de soudage ou autres circuits électriques.
- Ne jamais placer une torche de soudage sur une bouteille à gaz.
- Une électrode de soudage ne doit jamais entrer en contact avec une bouteille.
- Ne jamais souder une bouteille pressurisée – risque d'explosion.
- Utiliser seulement des bouteilles de gaz protecteur, régulateurs, tuyaux et raccords convenables pour cette application spécifique; les maintenir ainsi que les éléments associés en bon état.
- Ne pas tenir la tête en face de la sortie en ouvrant la soupape de la bouteille.
- Maintenir le chapeau de protection sur la soupape, sauf en cas d'utilisation ou de branchement de la bouteille.
- Lire et suivre les instructions concernant les bouteilles de gaz comprimé, les équipements associés et les publication P-1 CGA énumérées dans les normes de sécurité.

1.3 Dangers existant en relation avec le moteur



LE CARBURANT MOTEUR peut provoquer un incendie ou une explosion.

- Arrêter le moteur avant de vérifier le niveau de carburant ou de faire le plein.
- Ne pas faire le plein en fumant ou proche d'une source d'étincelles ou d'une flamme nue.
 - Ne pas faire le plein de carburant à ras bord; prévoir de l'espace pour son expansion.
 - Faire attention de ne pas renverser de carburant. Nettoyer tout carburant renversé avant de faire démarrer le moteur.
 - Jeter les chiffons dans un récipient ignifuge.

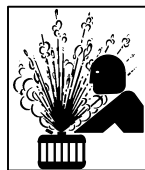

LA VAPEUR ET LE LIQUIDE DE REFROIDISSEMENT CHAUD peuvent provoquer des brûlures.

- Il est préférable de vérifier le liquide de refroidissement une fois le moteur refroidi pour éviter de se brûler.
 - Si le moteur est chaud et que le liquide doit être vérifié, opérer comme suivant :
 - Mettre des lunettes de sécurité et des gants, placer un torchon sur le bouchon du radiateur.
 - Dévisser le bouchon légèrement et laisser la vapeur s'échapper avant d'enlever le bouchon.



DES ORGANES MOBILES peuvent provoquer des blessures.

- Ne pas approcher les mains des ventilateurs, courroies et autres pièces en mouvement.
- Maintenir fermés et fixement en place les portes, panneaux, recouvrements et dispositifs de protection.
- Arrêter le moteur avant d'installer ou brancher l'appareil.
- Demander seulement à un personnel qualifié d'enlever les dispositifs de sécurité ou les recouvrements pour effectuer, s'il y a lieu, des travaux d'entretien et de dépannage.
- Pour empêcher tout démarrage accidentel pendant les travaux d'entretien, débrancher le câble négatif (-) de batterie de la borne.
- Ne pas approcher les mains, cheveux, vêtements lâches et outils des organes mobiles.
- Remettre en place les panneaux ou les dispositifs de protection et fermer les portes à la fin des travaux d'entretien et avant de faire démarrer le moteur.
- Avant d'intervenir, déposer les bougies ou injecteurs pour éviter la mise en route accidentelle du moteur.
- Bloquer le volant moteur pour éviter sa rotation lors d'une intervention sur le générateur.

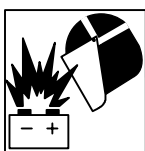

L'EXPLOSION DE LA BATTERIE peut RENDRE AVEUGLE.

- Toujours porter une protection faciale, des gants en caoutchouc et vêtements de protection lors d'une intervention sur la batterie.
- Arrêter le moteur avant de débrancher ou de brancher les câbles de batterie.
- Eviter de provoquer des étincelles avec les outils en travaillant sur la batterie.
- Ne pas utiliser le poste de soudage pour charger les batteries ou des véhicules de démarrage rapide.
- Observer la polarité correcte (+ et -) sur les batteries.
- Débrancher le câble négatif (-) en premier lieu. Le rebrancher en dernier lieu.

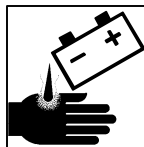

L'ACIDE DE LA BATTERIE peut provoquer des brûlures dans les YEUX et sur la PEAU.

- Ne pas renverser la batterie.
- Remplacer une batterie endommagée.
- Rincer immédiatement les yeux et la peau à l'eau.

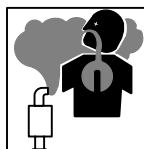

LES GAZ D'ÉCHAPPEMENT DU MOTEUR peuvent provoquer des accidents mortels.

- Utiliser l'équipement à l'extérieur dans des zones ouvertes et bien ventilées.
- En cas d'utilisation dans un endroit fermé évacuer les gaz d'échappement du moteur vers l'extérieur à distance des entrées d'air dans les bâtiments.



LA CHALEUR DU MOTEUR peut provoquer un incendie.

- Ne pas placer l'appareil sur, au-dessus ou à proximité de surfaces inflammables.
- Tenir à distance les produits inflammables de l'échappement.



LES ÉTINCELLES À L'ÉCHAPPEMENT peuvent provoquer un incendie.

- Empêcher les étincelles d'échappement du moteur de provoquer un incendie.
- Utiliser uniquement un pare-étincelles approuvé – voir codes en vigueur.

1.4 Dangers supplémentaires en relation avec l'installation, le fonctionnement et la maintenance



LA CHUTE DE L'APPAREIL peut blesser.

- Utiliser l'anneau de levage uniquement pour soulever l'appareil lui-même ; sans chariot, de bouteilles de gaz, remorque, ou autres accessoires.
- Utiliser un équipement de levage de capacité suffisante pour lever l'appareil.
- En utilisant des fourches de levage pour déplacer l'unité, s'assurer que les fourches sont suffisamment longues pour dépasser du côté opposé de l'appareil.

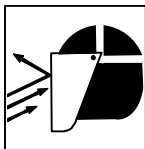

LES ÉTINCELLES VOLANTES risquent de provoquer des blessures.

- Porter un écran facial pour protéger le visage et les yeux.
- Affûter l'électrode au tungstène uniquement à la meuleuse dotée de protecteurs. Cette manœuvre est à exécuter dans un endroit sûr lorsque l'on porte l'équipement homologué de protection du visage, des mains et du corps.
- Les étincelles risquent de causer un incendie – éloigner toute substance inflammable.

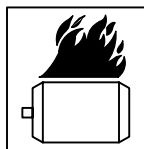

LE SURCHAUFFEMENT peut endommager le moteur électrique.

- Arrêter ou déconnecter l'équipement avant de démarrer ou d'arrêter le moteur.
- Ne pas laisser tourner le moteur trop lentement sous risque d'endommager le moteur électrique à cause d'une tension et d'une fréquence trop faibles.
- Ne pas brancher de moteur de 50 ou de 60 Hz à la prise de 100 Hz, s'il y a lieu.

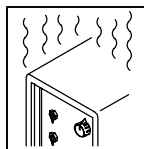

L'EMPLOI EXCESSIF peut SURCHAUFFER L'ÉQUIPEMENT.

- Laisser l'équipement refroidir ; respecter le facteur de marche nominal.
- Réduire le courant ou le facteur de marche avant de poursuivre le soudage.
- Ne pas obstruer les passages d'air du poste.

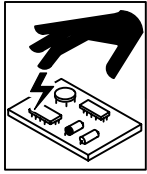

LES ÉLECTROSTATIQUES CHARGES peuvent endommager les circuits imprimés.

- Établir la connexion avec la barrette de terre avant de manipuler des cartes ou des pièces.
- Utiliser des pochettes et des boîtes antistatiques pour stocker, déplacer ou expédier des cartes de circuits imprimés.



UNE REMORQUE QUI BASCULE peut entraîner des blessures.

- Utiliser les supports de la remorque ou des blocs pour soutenir le poids.
- Installer convenablement le poste sur la remorque comme indiqué dans le manuel s'y rapportant.

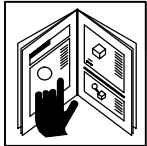

LIRE LES INSTRUCTIONS.

- Utiliser uniquement des pièces de rechange MILLER.
- Effectuer la maintenance et la mise en service d'après le manuel et celui du moteur.

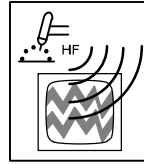

LE RAYONNEMENT HAUTE FRÉQUENCE (H.F.) risque de provoquer des interférences.

- Le rayonnement haute fréquence (H.F.) peut provoquer des interférences avec les équipements de radio-navigation et de communication, les services de sécurité et les ordinateurs.
- Demander seulement à des personnes qualifiées familiarisées avec des équipements électroniques de faire fonctionner l'installation.
- L'utilisateur est tenu de faire corriger rapidement par un électricien qualifié les interférences résultant de l'installation.
- Si le FCC signale des interférences, arrêter immédiatement l'appareil.
- Effectuer régulièrement le contrôle et l'entretien de l'installation.
- Maintenir soigneusement fermés les portes et les panneaux des sources de haute fréquence, maintenir les éclateurs à une distance correcte et utiliser une terre et un blindage pour réduire les interférences éventuelles.

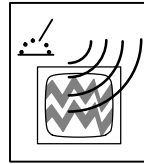

LE SOUDAGE À L'ARC risque de provoquer des interférences.

- L'énergie électromagnétique risque de provoquer des interférences pour l'équipement électronique sensible tel que les ordinateurs et l'équipement commandé par ordinateur tel que les robots.
- Veiller à ce que tout l'équipement de la zone de soudage soit compatible électromagnétiquement.
- Pour réduire la possibilité d'interférence, maintenir les câbles de soudage aussi courts que possible, les grouper, et les poser aussi bas que possible (ex. par terre).
- Veiller à souder à une distance de 100 mètres de tout équipement électronique sensible.
- Veiller à ce que ce poste de soudage soit posé et mis à la terre conformément à ce mode d'emploi.
- En cas d'interférences après avoir pris les mesures précédentes, il incombe à l'utilisateur de prendre des mesures supplémentaires telles que le déplacement du poste, l'utilisation de câbles blindés, l'utilisation de filtres de ligne ou la pose de protecteurs dans la zone de travail.

1.5 Principales normes de sécurité

Safety in Welding and Cutting, norme ANSI Z49.1, de l'American Welding Society, 550 N.W. Lejeune Rd, Miami FL 33126

Safety and Health Standards, OSHA 29 CFR 1910, du Superintendent of Documents, U.S. Government Printing Office, Washington, D.C. 20402.

Recommended Safe Practice for the Preparation for Welding and Cutting of Containers That Have Held Hazardous Substances, norme AWS F4.1, de l'American Welding Society, 550 N.W. Lejeune Rd, Miami FL 33126

National Electrical Code, NFPA Standard 70, de la National Fire Protection Association, Batterymarch Park, Quincy, MA 02269.

Safe Handling of Compressed Gases in Cylinders, CGA Pamphlet P-1, de la Compressed Gas Association, 1235 Jefferson Davis Highway, Suite 501, Arlington, VA 22202.

Règles de sécurité en soudage, coupage et procédés connexes, norme CSA W117.2, de l'Association canadienne de normalisation, vente de normes, 178 Rexdale Boulevard, Rexdale (Ontario) Canada M9W 1R3.

Safe Practices For Occupation And Educational Eye And Face Protection, norme ANSI Z87.1, de l'American National Standards Institute, 1430 Broadway, New York, NY 10018.

Cutting and Welding Processes, norme NFPA 51B, de la National Fire Protection Association, Batterymarch Park, Quincy, MA 02269.

1.6 Information sur les champs électromagnétiques

Données sur le soudage électrique et sur les effets, pour l'organisme, des champs magnétiques basse fréquence

L'extrait suivant est tiré des conclusions générales du document intitulé *Biological Effects of Power Frequency Electric & Magnetic Fields – Background Paper, OTA-BP-E-53 (Washington DC : U.S. Government Printing Office, mai 1989)*, publié par le Office of Technology Assessment du Congrès américain : «... il existe maintenant d'abondantes données scientifiques compilées à la suite d'expériences sur la cellule ou d'études sur des animaux et des humains, qui montrent clairement que les champs électromagnétiques basse fréquence peuvent avoir des effets sur l'organisme et même y produire des transformations. Même s'il s'agit de travaux de très grande qualité, les résultats sont complexes. Cette démarche scientifique ne nous permet pas d'établir un tableau d'ensemble cohérent. Pire encore, elle ne nous permet pas de tirer des conclusions finales concernant les risques éventuels, ni d'offrir des conseils sur les mesures à prendre pour réduire sinon éliminer les risques éventuels». (Traduction libre)

Afin de réduire les champs électromagnétiques dans l'environnement de travail, respecter les consignes suivantes :



- 1 Garder les câbles ensemble en les torsadant ou en les attachant avec du ruban adhésif.
- 2 Mettre tous les câbles du côté opposé de l'opérateur.
- 3 Ne pas courber et ne pas entourer pas les câbles autour de vous.
- 4 Garder le poste de soudage et les câbles le plus loin possible de vous.
- 5 Relier la pince de masse le plus près possible de la zone de soudure.

Consignes relatives aux stimulateurs cardiaques :

Les consignes mentionnées précédemment font partie de celles destinées aux personnes ayant recours à un stimulateur cardiaque. Veuillez consulter votre médecin pour obtenir plus de détails.

2. Definitions

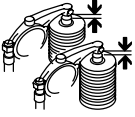
2.1 Symbols and Definitions

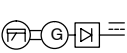
	Stop Engine		Fast (Run, Weld/Power)		Fast/Slow (Run/Idle)		Slow (Idle)
	Start Engine		Glow Plug		Temperature		Fuel
	Engine Oil		Remote 14		Panel/Local		On
	Check Injectors/ Pump		Check Valve Clearance		Battery (Engine)		Volts
A	Amperes		Stick (SMAW)		Arc Force (DIG)		TIG (GTAW)
	Engine-Driven, Single-Phase Alternator With Rectifier		Engine		Read Operator's Manual		Circuit Breaker
+	Positive	—	Negative		Alternating Current (AC)		Direct Current (DC)
	Certified/Trained Mechanic		Time		Protective Earth (Ground)		Input
	Output	U₀	Rated No Load Voltage (Average)	U₂	Conventional Load Voltage	I₂	Rated Welding Current
n	Rated Load Speed	n₀	Rated No Load Speed	n₁	Rated Idle Speed	X	Duty Cycle
I	Current	P	Power		Three Phase		Single Phase
h	Hours	s	Seconds	min⁻¹	rpm		

2.2 General Precautionary Label

3/96

A. Warning! Watch Out! There are possible hazards as shown by the symbols.

B. Become trained and read the instructions before working on the machine or welding.

1 Electric shock from welding electrode or wiring can kill.

1.1 Wear dry insulating gloves. Do not touch electrode with bare hand. Do not wear wet or damaged gloves.

1.2 Protect yourself from electric shock by insulating yourself from work and ground.

1.3 Do not work on unit if engine is running. Stop engine first.

2 Breathing welding fumes can be hazardous to your health.

2.1 Keep your head out of the fumes.

2.2 Use forced ventilation or local exhaust to remove the fumes.

2.3 Use ventilating fan to remove fumes.

3 Welding sparks can cause explosion or fire.

3.1 Keep flammables away from welding. Do not weld near flammables.

3.2 Welding sparks can cause fires. Have a fire extinguisher nearby, and have a watchperson ready to use it.

3.3 Do not weld on drums or any closed containers.

4 Arc rays can burn eyes and injure skin.

4.1 Wear hat and safety glasses. Use ear protection and button shirt collar. Use welding helmet with correct shade of filter. Wear complete body protection.

5 Do not remove or paint over (cover) the label.

6 Engine fuel plus flames or sparks can cause fire.

6.1 Do not smoke while fueling or if near fuel.

6.2 Stop engine before fueling.

6.3 Do not fuel a hot engine.

7 Engine exhaust gases can kill.

7.1 Vent exhaust outside.

7.2 Use unit outside.



S-176 105-A

2.3 Battery Charging Label

3/96

- 1 Warning! Watch Out! There are possible hazards as shown by the symbols.
- 2 Do not smoke and keep matches and flames away from battery.
- 3 Sparks can cause battery gases to explode. Battery explosion can blind and injure. Wear a face shield.
- 4 Battery acid can burn skin. Do not spill acid.
- 5 Read Owner's Manual.
- 6 Wear rubber gloves.
- 7 Dead battery
- 8 Engine block
- 9 Fully charged battery
- 10 Do not connect last negative cable to dead battery – connect instead to engine block.
- 11 Jumper cables – observe polarity and make connections in numbered sequence shown.
- 12 Once dead battery is charged, disconnect cables in sequence shown.

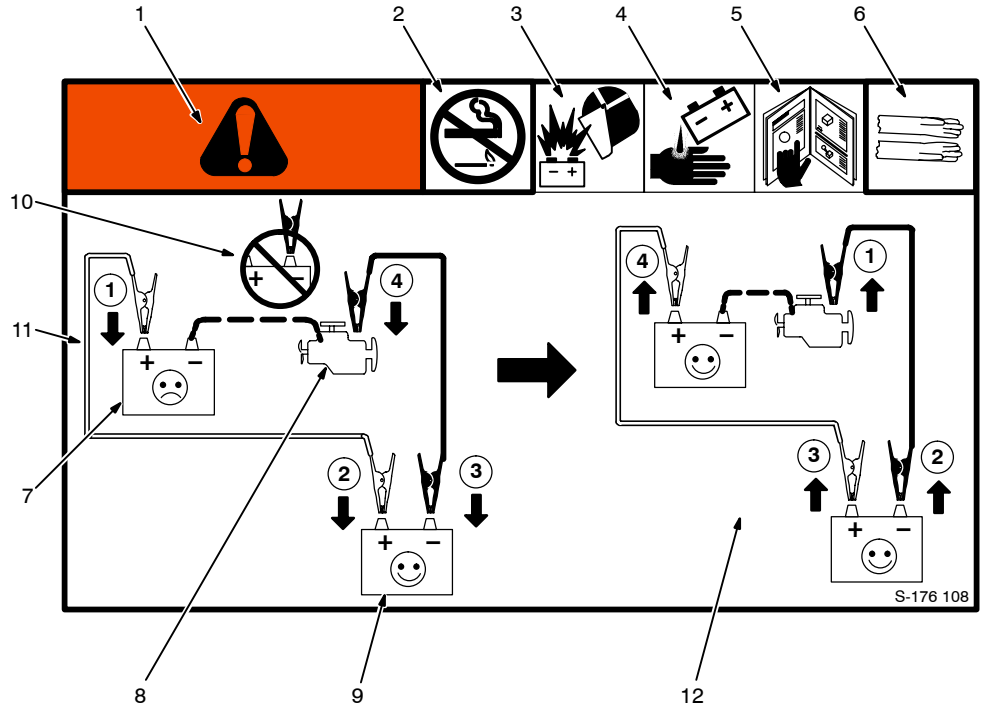

2.4 Fan and Moving Parts Label

3/96

- 1 Warning! Watch Out! There are possible hazards as shown by the symbols.
- 2 Moving parts, such as fans, rotors, and belts, can cut fingers and hands and cause injury. Keep away from moving parts.

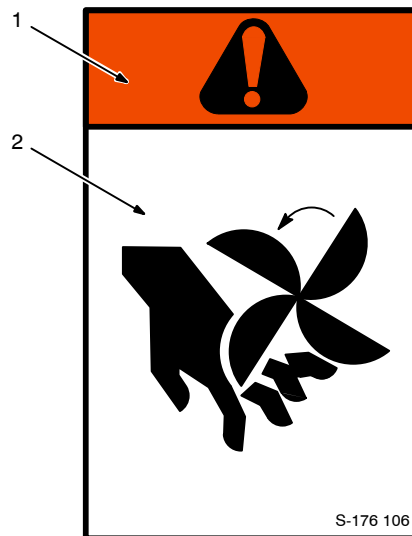

2.5 Hot Muffler Label

3/96

- 1 Warning! Watch Out! There are possible hazards as shown by the symbols.
- 2 Hot muffler and exhaust pipes can cause severe burns. Do not touch hot muffler or pipes.

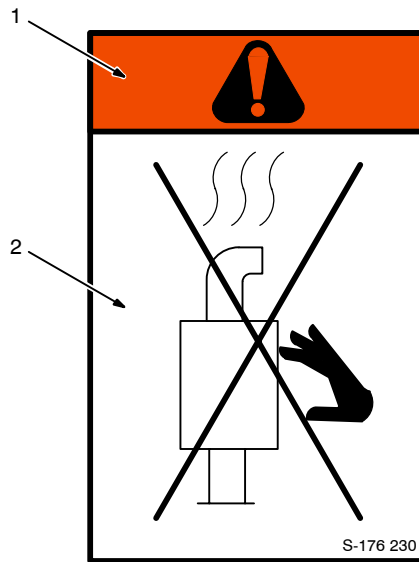

2.6 Diesel Fuel Label

3/96

- 1 Warning! Watch Out! There are possible hazards as shown by the symbols.
- 2 Engine fuel plus flames or sparks can cause fire.
- 3 Do not smoke while fueling or if near fuel.
- 4 Stop engine before fueling.
- 5 Do not fuel a hot engine.
- 6 Use Diesel Fuel only.

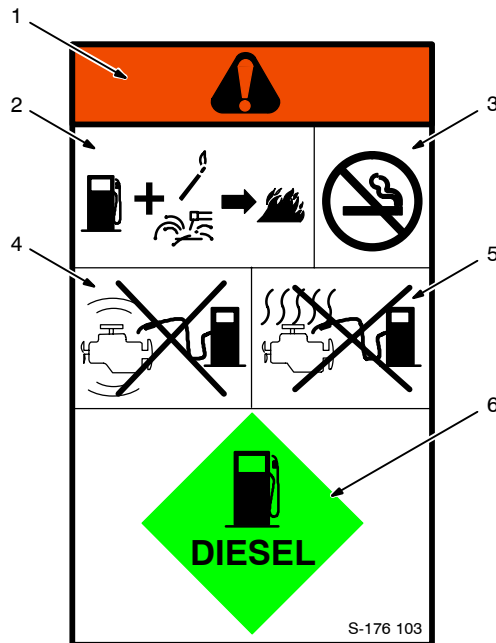

2.7 Falling Equipment Label

- 1 Warning! Watch Out! There are possible hazards as shown by the symbols.
- 2 Falling equipment can cause serious injury and damage.
- 3 Use lifting eye to lift or move unit only. Use proper equipment when lifting.
- 4 Do not use lifting eye to lift and support unit and trailer or other heavy devices or accessories.

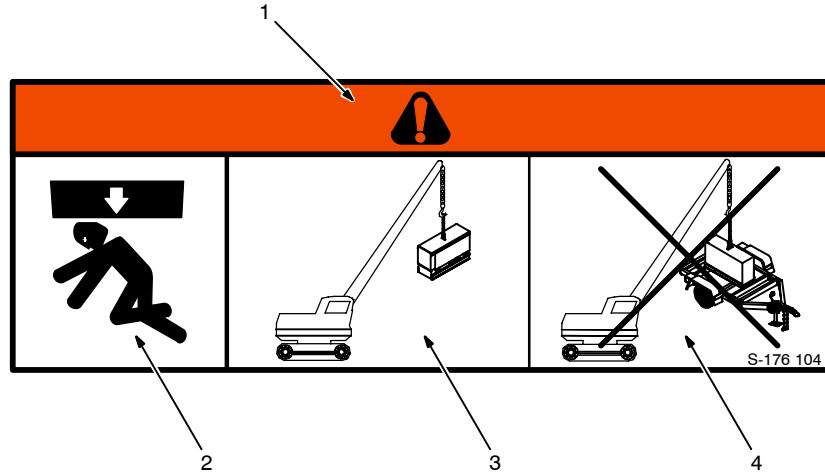

3/96

2.8 Activation Tag

- 1 Remove unit from shipping crate. Remove Owner's Manual from unit. Follow instructions to install muffler.
- 2 Read Owner's Manual. Read labels on unit.
- 3 Use Diesel Fuel only, and fill fuel tank. Leave room for expansion.
- 4 Check oil level. Add oil if necessary.
- 5 Warning! Watch Out! There are possible hazards as shown by the symbols. During the first 50 hours of operation, do not exceed 225 amperes of weld output or 7 kVA of auxiliary power output.
- 6 Warning! Watch Out! There are possible hazards as shown by the symbols. Read Owner's Manual. Follow instructions to activate battery.

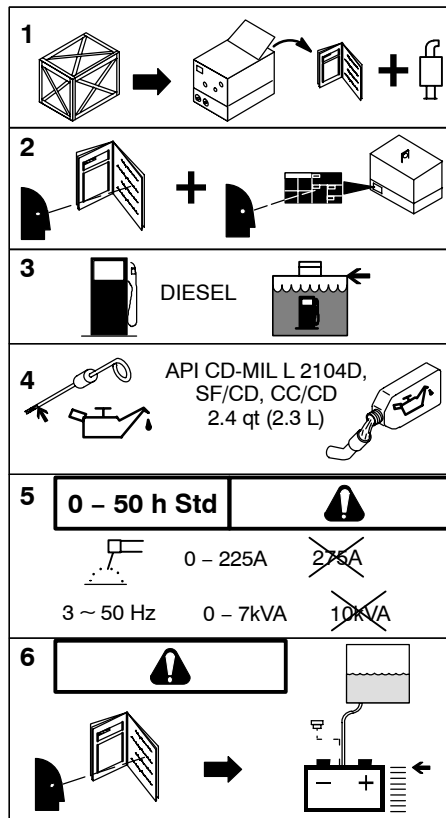

3/96

S-176 107-A





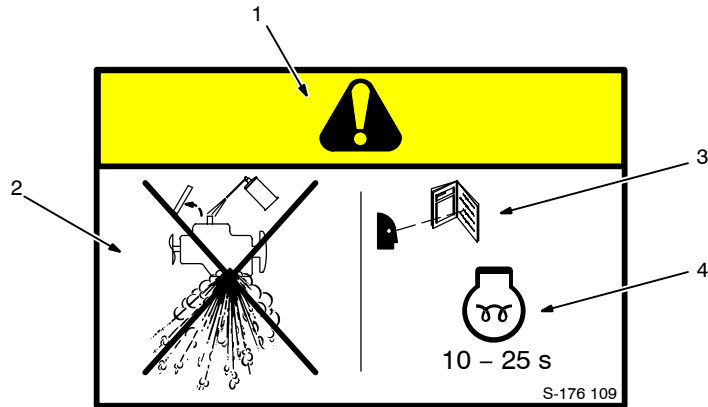

2.9 Do Not Use Ether Label

3/96

- 1 Warning! Watch Out! There are possible hazards as shown by the symbols.
- 2 Ether will damage engine. Do not use ether as a starting aid.
- 3 Read Owner's Manual.
- 4 Use glow plugs for 10–25 seconds to aid starting in cold weather.



2.10 Manufacturer's Rating Label

		METRO 250D			
		20A/21V		280A/31V	
		X	35%	60%	100%
		I_2		280A	250A
	$U_0 = 58V$	U_2		31V	30V
		20A/11V		280A/21V	
		X	35%	60%	100%
		I_2		280A	250A
	$U_0 = 58V$	U_2		21V	20V
	$n = 3600 \text{ min}^{-1}$				
	$n_0 = 3700 \text{ min}^{-1}$	$n_1 = 2200 \text{ min}^{-1}$			
			PROTECTION CLASS I		
1 ~ 60 Hz	120/240V	10kVA	42A		

S-176 095-C

3. Specifications

3.1 Weld, Power, and Engine Specifications

Rated Welding Output	Amperage Range	Maximum Open-Circuit Voltage DC	Auxiliary Power Rating	Engine	Fuel Capacity	Average Sound Level
280 A, 31 V DC, 60% Duty Cycle 250 A, 30 V DC, 100% Duty Cycle	20 – 280	61 (Average)	Single-Phase, 10 kVA/kW, 42 A, 120/240 V, 60 Hz	Deutz/Ruggerini RD211 Air-Cooled, Two-Cylinder, 23 HP Diesel Engine	11.8 US gal (44.6 L)	74.5 dB(A) at 23 ft (7 m)

3.2 Dimensions, Weights, and Operating Angles



Dimensions

Height	41 in (1041 mm)
Width	30 in (762 mm)
Depth	54-1/2 in (1384 mm)
A	29 in (737 mm)
B	36-3/4 in (933 mm)
C	9/16 in (14 mm) Dia.

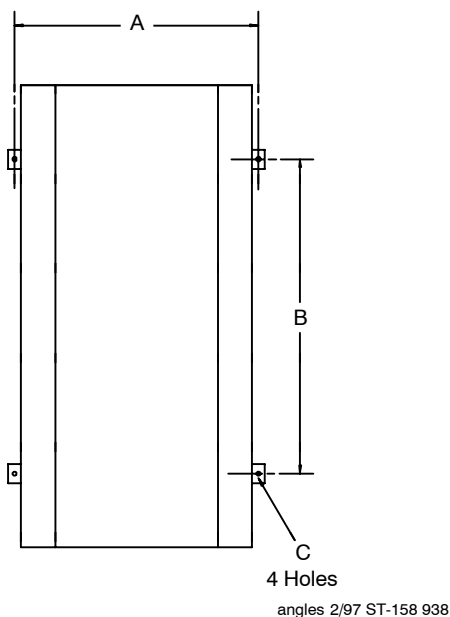

- ▲ Do not exceed operating angles while running or engine damage will occur.
- ▲ Do not move or operate unit where it could tip.

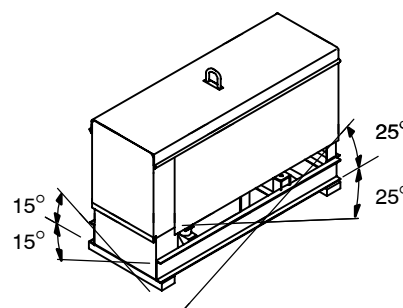

Weight

960 lb (435 kg)

3.3 Volt-Ampere Curve

The volt-ampere curve shows the minimum and maximum voltage and amperage output capabilities of the welding generator. Curves of all other settings fall between the curves shown.

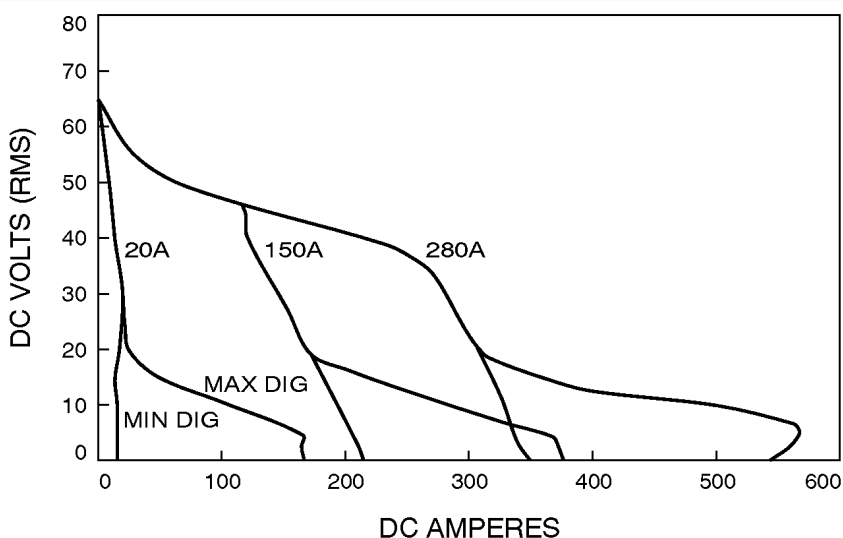

SA-180 261

3.4 Fuel Consumption

SA-180 263-A

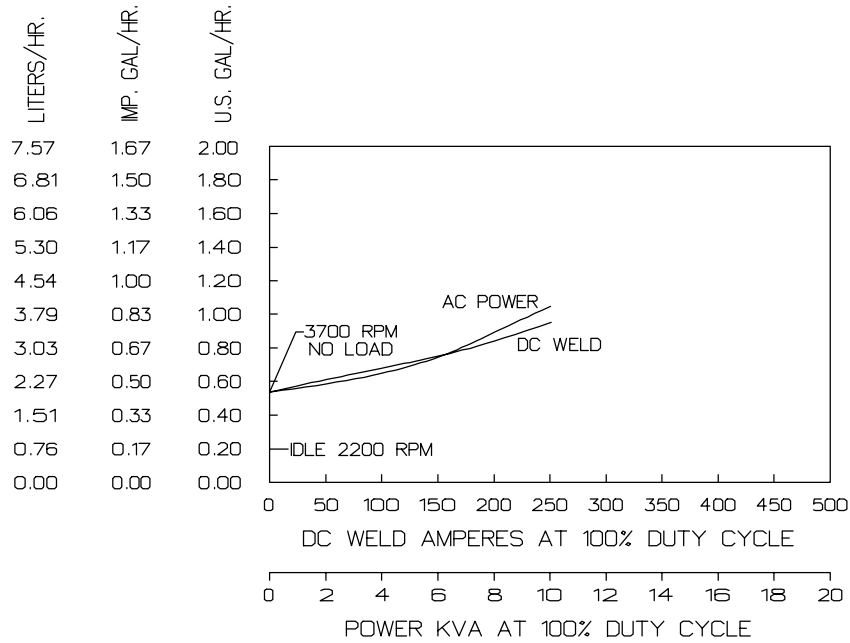

3.5 Duty Cycle and Overheating

duty1 5/95 / SB-180 262



Duty Cycle is percentage of 10 minutes that unit can weld at rated load without overheating.

▲ Exceeding duty cycle can damage unit and void warranty.

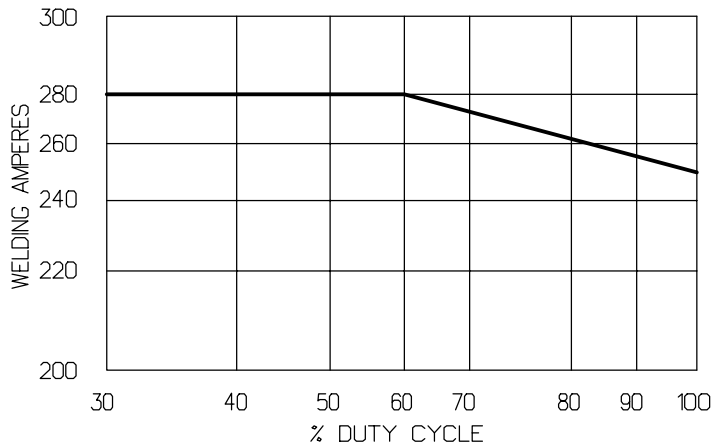

60% Duty Cycle At 280 Amperes

100% Duty Cycle At 250 Amperes

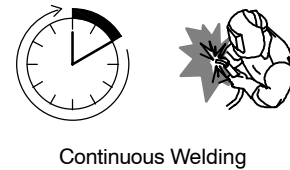
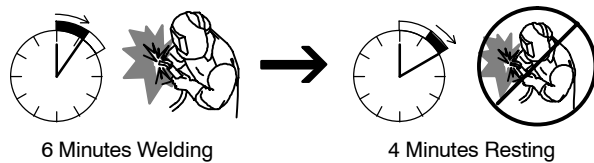

3.6 AC Auxiliary Power Curve

SA-180 260

The auxiliary power curve shows the auxiliary power in amperes available at the receptacles.

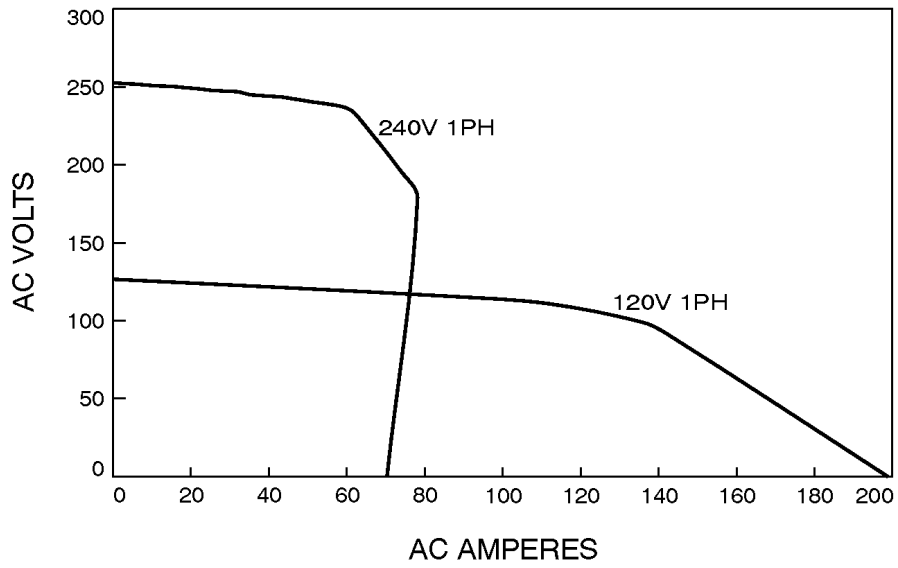

4. Installation

4.1 Installing Welding Generator

install1 1/97 - Ref. ST-800 652 / Ref. ST-800 477-A / ST-158 936-A / S-0854



- 1 Generator Base
- 2 Metal Vehicle Frame
- 3 Equipment Grounding Terminal
- 4 Grounding Cable

Use #10 AWG or larger insulated copper wire.

▲ If unit does not have GFCI receptacles, use GFCI-protected extension cord.

Movement

▲ Do not lift unit from end.

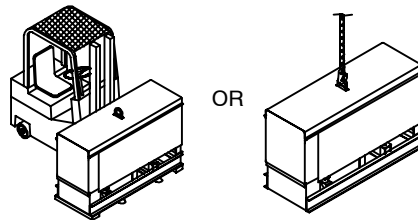

Airflow Clearance

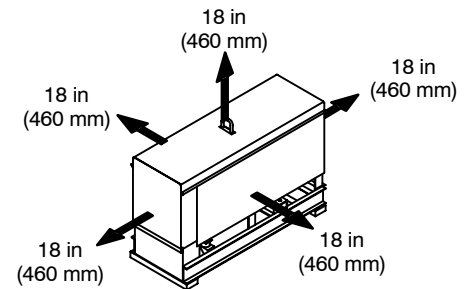

Location

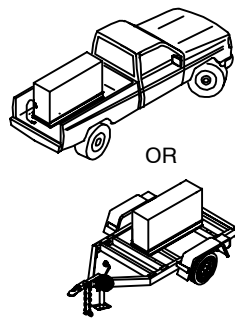

Grounding

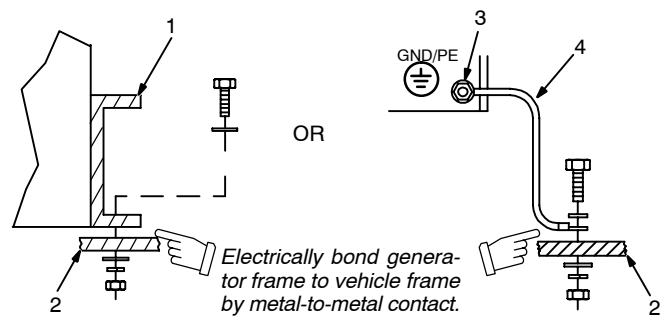

4.2 Connecting Battery and Installing Exhaust Pipe

ST-801 079-A / Ref. ST-175 918-C

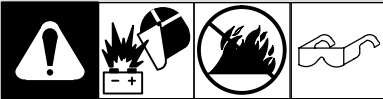

▲ Stop engine.

☞ Installation of exhaust pipe is optional.

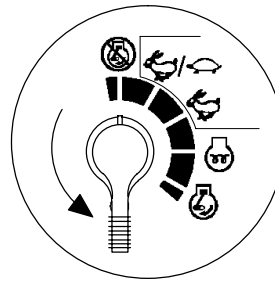

Tools Needed:
 7/16, 1/2 in

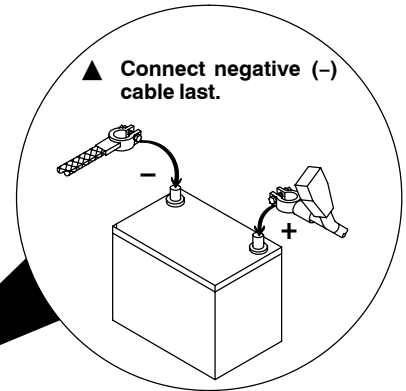
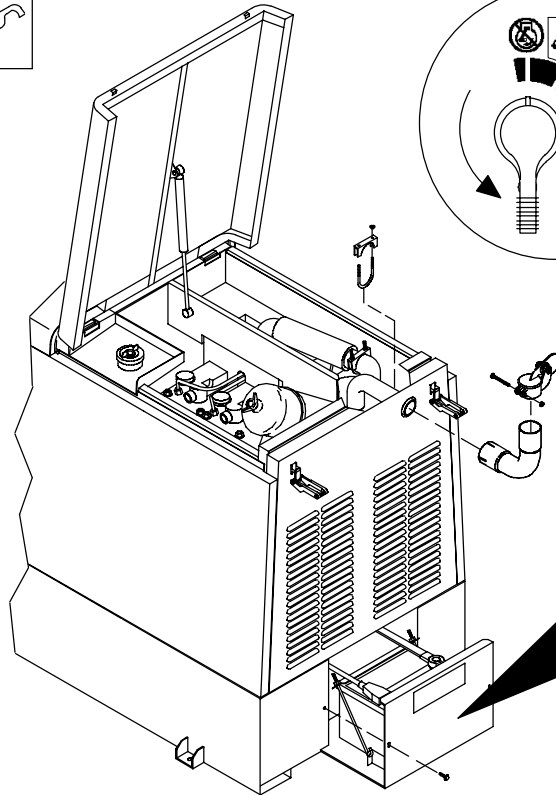

4.3 Engine Prestart Checks

Ref. ST-159 219-D

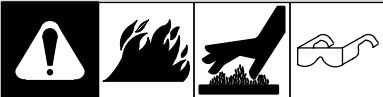

Check all fluids daily. Unit must be cold and on a level surface. Oil may be added at either oil fill.

Engine stops if oil pressure is low.

▲ Heavy loading during first 50 hours will damage engine. Keep load less than 225A (weld) or 7 kVA (power) for first 50 hours.

1 Exhaust Pipe

If unburned fuel and oil collect in exhaust pipe during run-in, see Section 9.

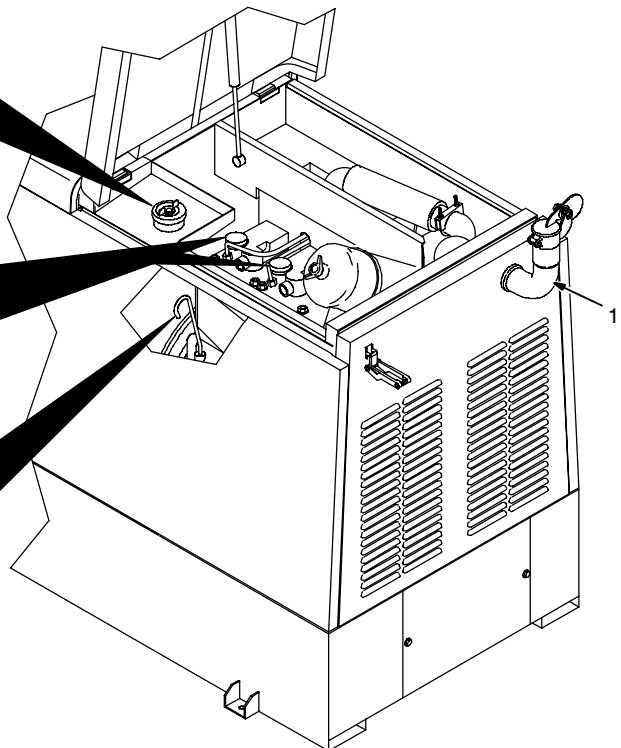
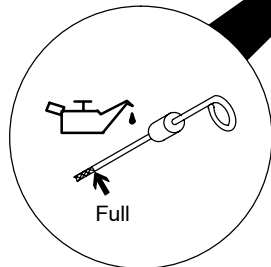
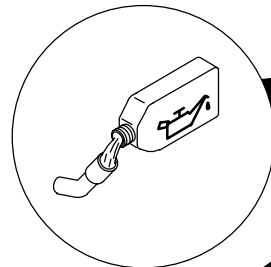
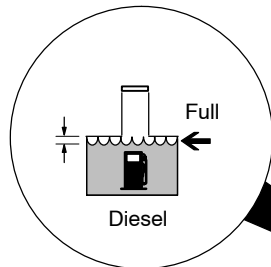

4.4 Connecting to Weld Output Terminals

Ref. ST-158 936-D / Ref. ST-175 918-C



- 1 Positive (+) Weld Output Terminal
- 2 Negative (-) Weld Output Terminal

For Direct Current Electrode Positive (DCEP), connect work cable to Negative (-) terminal and electrode cable (Stick) or torch cable (TIG) to Positive (+) terminal.

For Direct Current Electrode Negative (DCEN), reverse cable connections.

If unit has optional polarity switch, connect work cable to Work terminal and electrode and torch cable to electrode terminal.

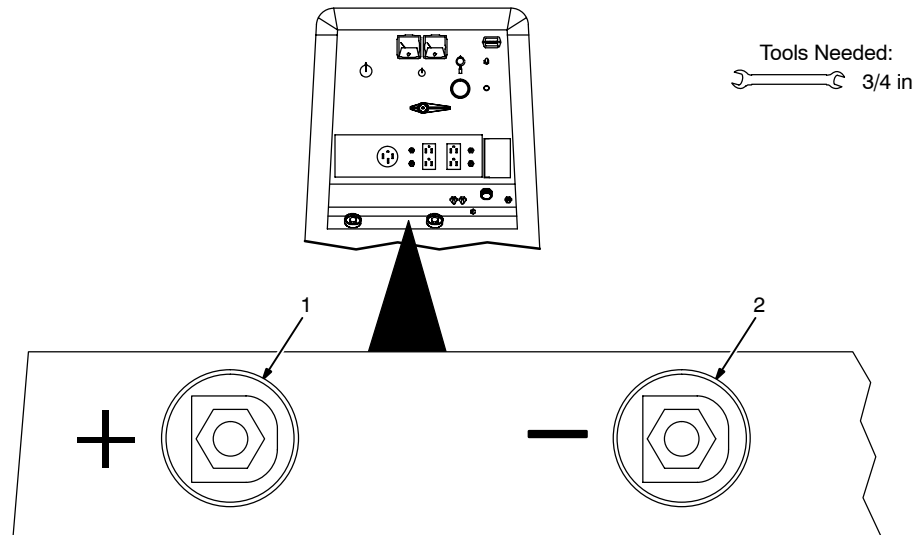

4.5 Selecting Weld Cable Sizes

Welding Amperes	Total Cable (Copper) Length in Weld Circuit Not Exceeding							
	100 ft (30 m) or Less		150 ft (45 m)	200 ft (60 m)	250 ft (70 m)	300 ft (90 m)	350 ft (105 m)	400 ft (120 m)
	10 – 60% Duty Cycle	60 – 100% Duty Cycle	10 – 100% Duty Cycle					
100	4	4	4	3	2	1	1/0	1/0
150	3	3	2	1	1/0	2/0	3/0	3/0
200	3	2	1	1/0	2/0	3/0	4/0	4/0
250	2	1	1/0	2/0	3/0	4/0	2-2/0	2-2/0
300	1	1/0	2/0	3/0	4/0	2-2/0	2-3/0	2-3/0
350	1/0	2/0	3/0	4/0	2-2/0	2-3/0	2-3/0	2-4/0
400	1/0	2/0	3/0	4/0	2-2/0	2-3/0	2-4/0	2-4/0

Weld cable size (AWG) is based on either a 4 volts or less drop or a current density of at least 300 circular mils per ampere.

S-0007-D

4.6 Remote 14 Receptacle RC1 Information

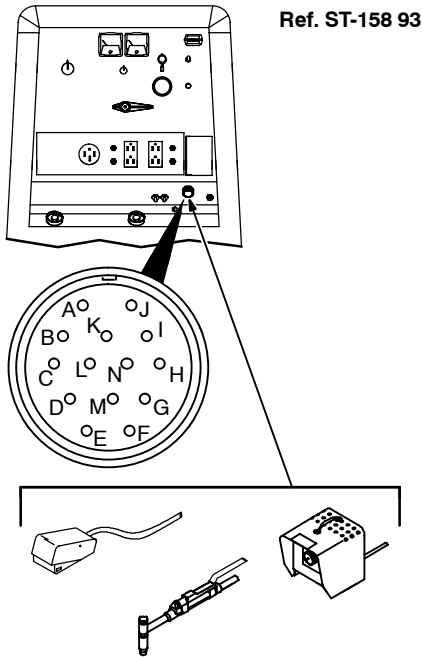

REMOTE 14

Socket*

Socket Information

Socket*	Socket Information
A	24 volt ac with respect to socket G. Protected by circuit breaker CB5.
B	Contact closure to A completes 24 volt ac contactor control circuit.
G	Circuit common for 24 volt ac circuit.
C	0 to +10 volts dc output to remote control with respect to socket D.
D	Remote control circuit common.
E	0 to +10 volts dc input command signal from remote control with respect to socket D.
K	Chassis common.

*The remaining sockets are not used.

5. Operating the Welding Generator

5.1 Front Panel Controls

Ref. ST-175 918-C



▲ **Heavy loading during first 50 hours will damage engine. Keep load less than 225A (weld) or 7 kVA (power) for first 50 hours.**

1 Engine Control Switch

Use switch to operate glow plug (optional – see table), start engine, select speed, and stop engine.

In Run/Idle position, engine runs at idle speed at no load, and weld/power speed under load. In Run position, engine runs at weld/power speed.

☞ Use Run position for HF-start TIG welding, and to maintain weld/power speed under light auxiliary power loads.

2 Idle Lock Switch

Use switch to lock engine in idle speed during start-up (see table).

▲ **Do not weld or use ac receptacles with switch in Idle position.**

To Start: move Idle Lock switch to Idle position and Engine Control switch to Start position. Release Engine Control switch when engine starts. Do not crank engine if engine is still turning. Move Idle Lock switch to Run/Idle position after engine warms.

To Stop: turn Engine Control switch to Stop position.

3 Engine Hour Meter

4 Fuel Gauge

5 Engine Oil Pressure Light

Engine stops and light goes on if oil pressure is too low.

6 Polarity Switch (Optional)

Use switch to change polarity of weld output.

7 Arc Force (Dig) Control

Use control to automatically increase amperage as arc length is decreased, to assist in arc starts, and reduce the chance of the electrode freezing in the puddle. Set at minimum for TIG welding.

8 Amperage Control

9 Voltmeter (Optional)

10 Ammeter (Optional)

11 Amperage Control Switch

Use switch to select front panel or remote amperage control.

12 Output (Contactor) Control Switch

Use switch to control remote contactor if connected to remote 14 receptacle RC1.

▲ **Weld output terminals are energized when Output (Contactor) Control switch is On and engine is running.**

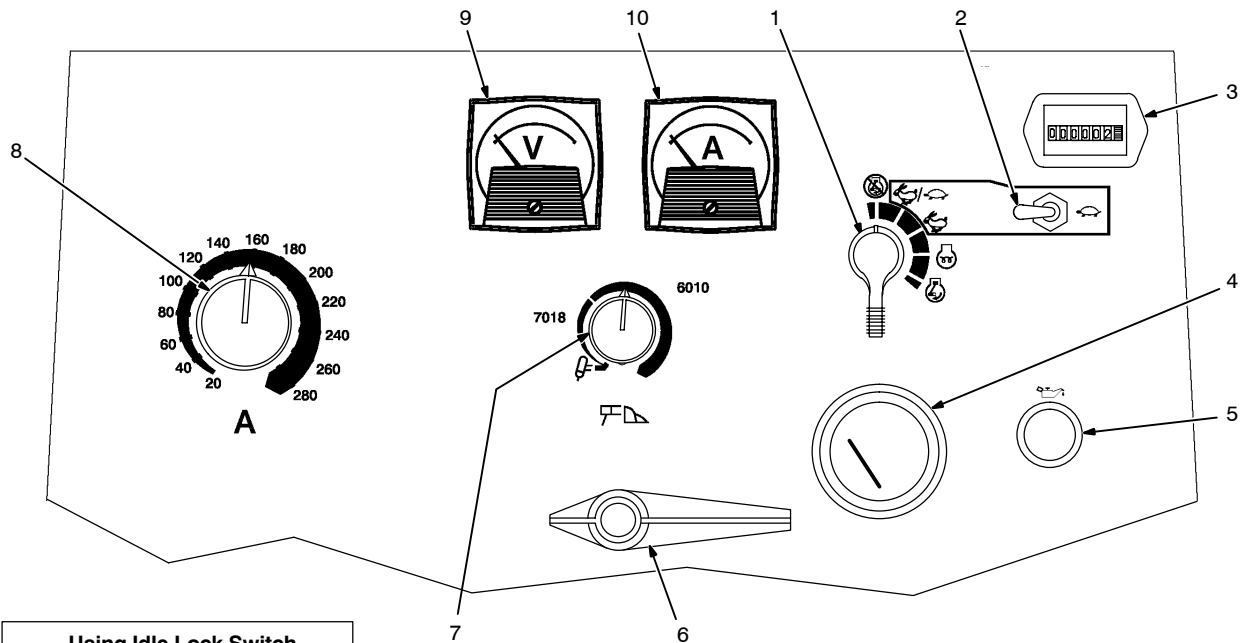

Using Idle Lock Switch	
	2150 rpm
	2150 rpm
	2150 rpm (No Load) 3700 rpm (Load)
	3700 rpm

Using Glow Plug		
	70°F (21°C)	0 s
	32°F (0°C)	10 s
	-4°F (-20°C)	20 s

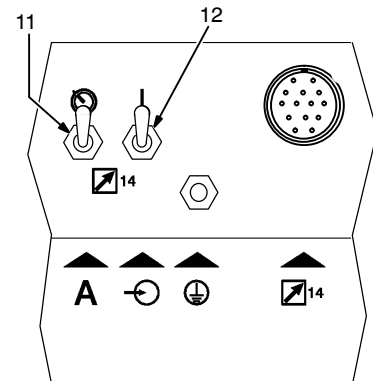

5.2 Remote Amperage and Contactor Control

Ref. ST-158 936-D / Ref. ST-175 918-C



▲ Weld output terminals are energized when Output (Contactor) Control switch is On and engine is running.

1 Remote 14 Receptacle RC1
Connect optional remote control to RC1 (see Section 4.6).

☞ Place Engine Control switch in Run position for HF-start TIG welding.

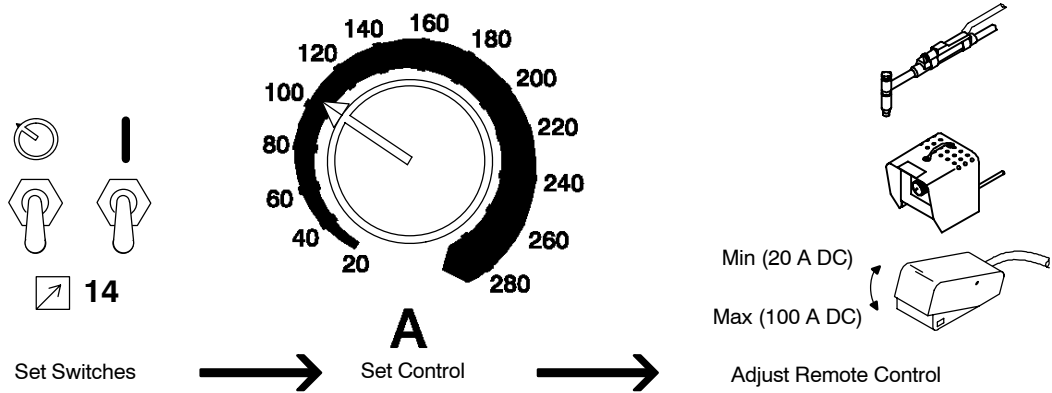
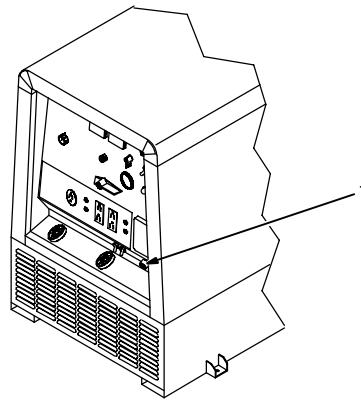

6. Operating Auxiliary Equipment

6.1 Auxiliary Power Receptacles

ST-175 902 / S-180 259



☞ Place Engine Control switch in Run position to maintain weld/power speed under light auxiliary power loads.

☞ Press button to reset circuit breaker. If a circuit breaker continues to open, contact a Factory Authorized Service Agent.

- 1 120 V 15 A AC Duplex Receptacle RC1
- 2 120 V 15 A AC Duplex Receptacle RC2
- 3 120/240 V 42 A AC Straight Receptacle RC3
- 4 120/240 V 42 A AC Twistlock Receptacle RC4 (Optional)

RC1 and RC2 supply 60 Hz single-phase power at weld/power speed. Maximum out-

put from each duplex receptacle is 1.8 kVA/kW.

RC3 and RC4 supply 60 Hz single-phase power at weld/power speed. Maximum output from RC3 or RC4 is 10 kVA/kW.

Combined output of receptacles is limited to 10 kVA/kW output of generator. If maximum output is exceeded, auxiliary equipment may stop or not run properly.

5 Circuit Breakers CB1 And CB2

CB1 and CB2 protect RC1 and RC2 from overload. If a circuit breaker opens, the receptacle does not work.

6 Circuit Breakers CB3 And CB4

CB3 and CB4 protect all the receptacles from overload. If CB3 opens, RC1, RC3 and RC4 do not work. If CB4 opens, RC2, RC3

and RC4 do not work. 120 volts may still be present at RC3 and RC4.

7 Ground Fault Circuit Interrupter GFCI1 GFCI1 provides ground fault protection for the auxiliary power receptacles. If a ground fault is detected, GFCI Reset button pops out and the receptacles do not work. Check for faulty tools plugged in receptacles. Press button to reset.

☞ At least once a month, run engine at weld/power speed and press test button to verify GFCI is working properly.

8 Auxiliary Power While Welding Table

☞ Auxiliary power available at ac receptacles decreases as weld amperage increases.

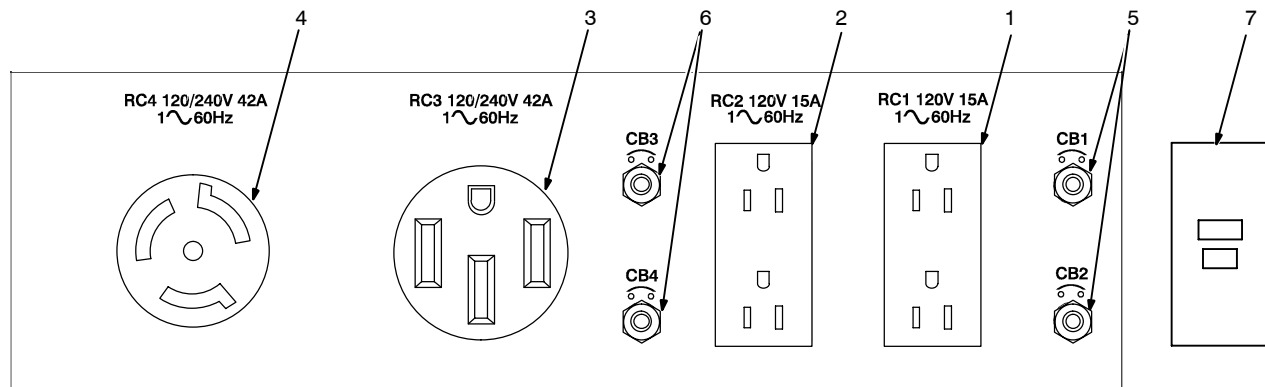

METRO 250D				
1 ~ 60 Hz 240 V		1 ~ 60 Hz 120 V		
I	P	I	P	I
280 A	1.3 kVA	5.5 A	1.3 kVA	11.0 A
250 A	2.5 kVA	10.4 A	2.5 kVA	20.8 A
200 A	4.4 kVA	18.3 A	4.4 kVA	36.7 A
150 A	6.1 kVA	25.4 A	6.0 kVA	50.0 A
100 A	7.6 kVA	31.7 A	6.0 kVA	50.0 A
50 A	8.9 kVA	37.1 A	6.0 kVA	50.0 A
0 A	10.0 kVA	41.7 A	6.0 kVA	50.0 A

S-180 259-A

7. Maintenance & Troubleshooting

7.1 Routine Maintenance

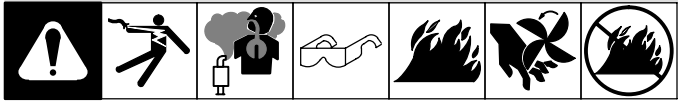

Recycle engine fluids.

▲ Stop engine before maintaining.

See also *Engine Manual and Maintenance Label*. Service engine more often if used in severe conditions.

8 h

Check fluid levels. See Section 4.3.



Wipe up spills.



50 h

Clean air filter element. See Section 7.5.

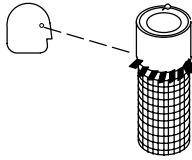

Clean and tighten weld connections.

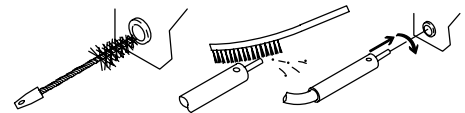

100 h

Change oil. See Section 7.3 and maintenance label.

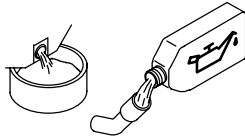

Clean and tighten battery connections. See Section 4.2.

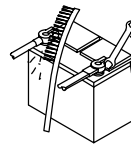

Clean cooling system. See engine manual.

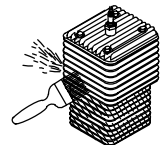

200 h

Change oil filter. See Section 7.3 and maintenance label.

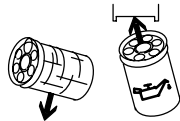

Change fuel filter. See Section 7.4.

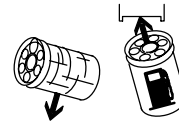

Change fuel filter. See Section 7.4.

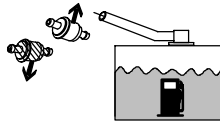

Replace unreadable labels.

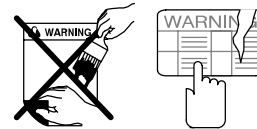

250 h

Check and clean spark arrestor. See Section 7.8.

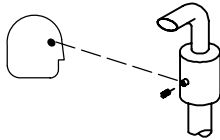

300 h

Check valve clearance. See engine manual.

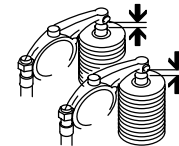

500 h

Repair or replace cracked cables.

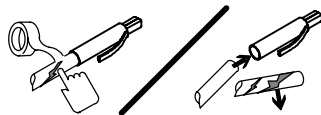

Test/time injectors. See engine manual.

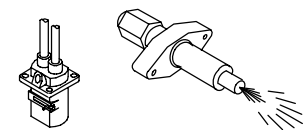

1000 h

Blow out or vacuum inside. During heavy service, clean monthly.

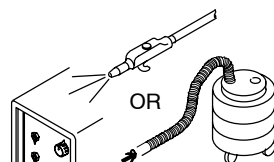

DEUTZ/RUGGERINI RD211 DIESEL ENGINE

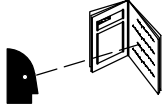

<p>12 V BCI 58 430 A @ 0°F (-18°C)</p>	<p>2200 min⁻¹ 3700 min⁻¹</p>
<p>Deutz 77-644-39</p>	<p>Deutz 77-656-19</p>
<p>DIESEL</p>	<p>DIN 51 601 BS 2869: A1, A2 ASTM D 975-81: 1-D, 2-D VV-F 800C: DF-A, DF-1, DF-2 S < = .5%</p> <p>11.8 gal (44.6 l)</p>

8 Hrs.

50 Hrs.

MILLER 065 604
Nelson 70098
Donaldson P10-2745

100 Hrs.

API CD-MIL L 2104D, SF/CD, CC/CD
2.4 qt (2.3 L)

°C	°F
+40	+104
+30	+86
+20	+59
+10	+32
0	+32
-10	-15
-20	-10

10W, 20W, 30, 40, 50, 15W-40

200 Hrs.

MILLER 066 702
Deutz 77-175-24

MILLER 066 893
Deutz 77-175-19

MILLER 066 113

250 Hrs.

300 Hrs.

72° F (20° C)
0.006 in (0.15 mm)

S-157 812-E

7.3 Changing Engine Oil and Oil Filter

Ref. ST-159 219-D / Ref. ST-159 215-E / Ref. ST-175 918-C / Ref. S-0842

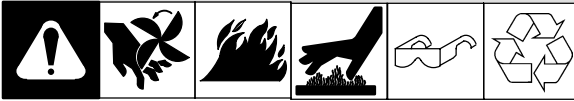

▲ Stop engine.

See engine manual for oil/filter change procedure. Drain oil while engine is warm.

- 1 Oil Fill Caps (Use Either Cap)
- 2 Oil Drain Valve

▲ Close oil drain valve and cap before adding oil and running engine.

- 3 Oil Filter
- 4 Dipstick

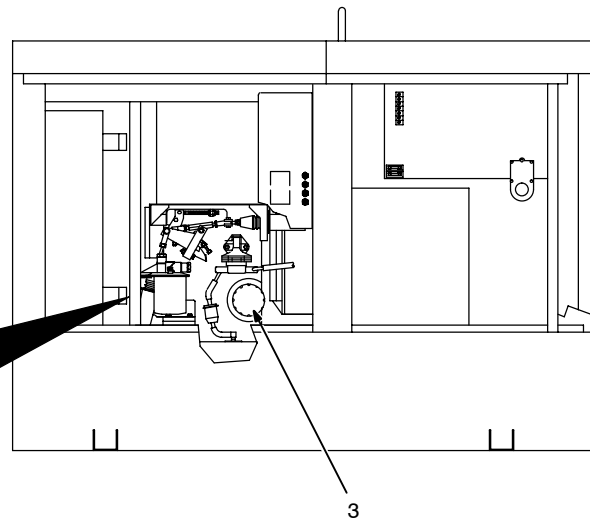
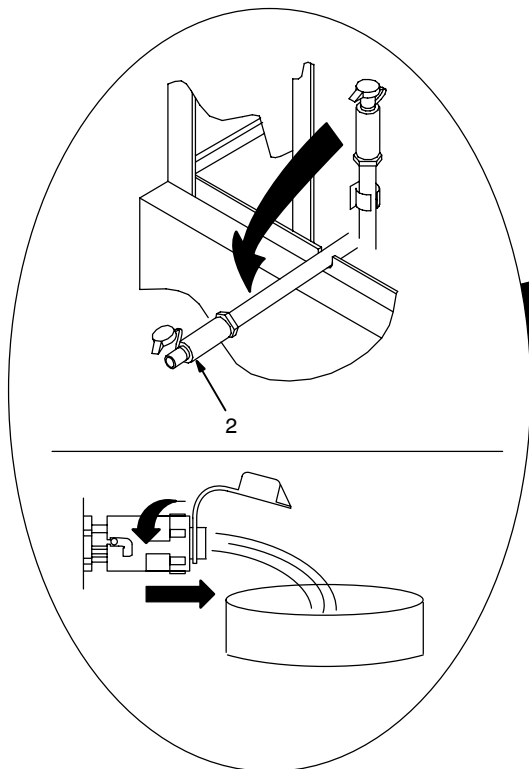
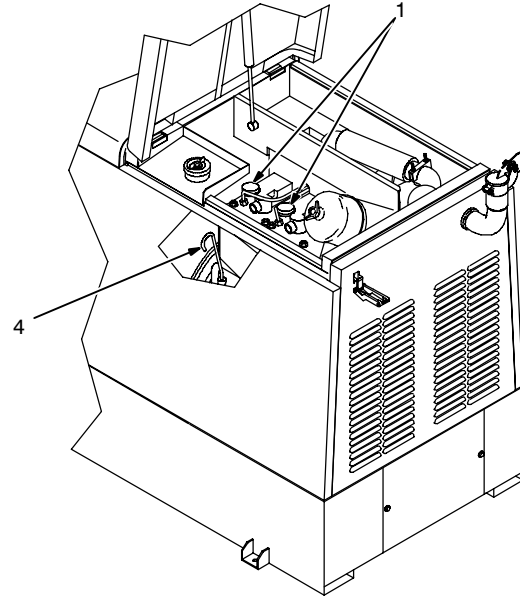
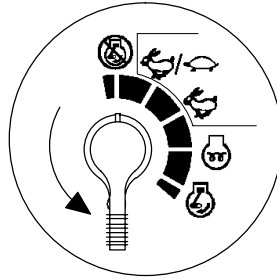

Tools Needed:

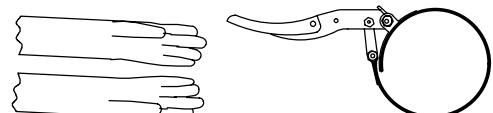

7.4 Changing Fuel Filters

Ref. ST-159 215-E / Ref. ST-175 918-C

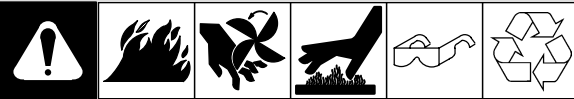

▲ Stop engine and let cool.

1 Secondary Fuel Filter

Remove filter.

Apply thin film of oil to gasket on new filter. Install filter.

2 Primary Fuel Filter

3 Fuel Line

Remove filter. Inspect all fuel lines and replace if cracked or worn.

Install new filter and clamps. Wipe up any spilled fuel.

Start engine, and check for fuel leaks.

▲ Stop engine.

Tighten connections as necessary.

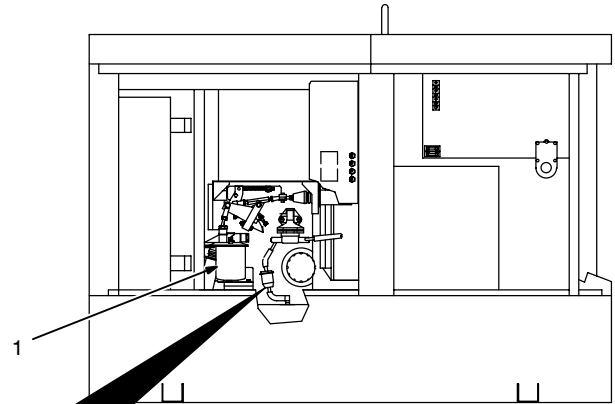
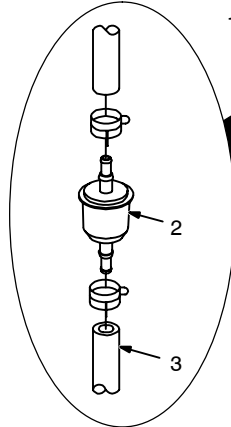
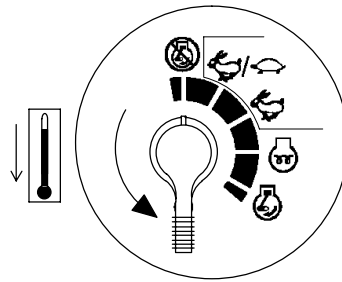

Tools Needed:

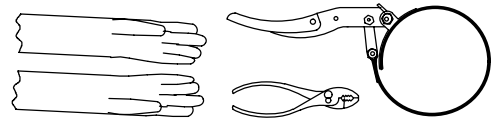

7.5 Servicing Air Cleaner

Ref. ST-175 918-C / Ref. ST-159 219-D / Ref. S-0698-B



▲ Stop engine.

▲ Do not run engine without air cleaner or with dirty element.

▲ Use only high pulsation-type replacement filter listed on maintenance label or engine damage may occur.

1 Dust Cap

2 Element

3 Housing

4 Dust Valve

To Clean air filter:

Wipe off cap and housing. Remove cap and dump out dust. Remove element. Reinstall cap to keep out dust.

▲ Do not clean housing with air hose.

Clean element with compressed air only. Keep nozzle at least 1 in (25 mm) from inside of element. Max. air pressure: 30 psi (207 kPa). Do not remove plastic fins. Replace element and valve if damaged. Replace element yearly or after six cleanings.

Reinstall element and cap (cap arrows pointing down).

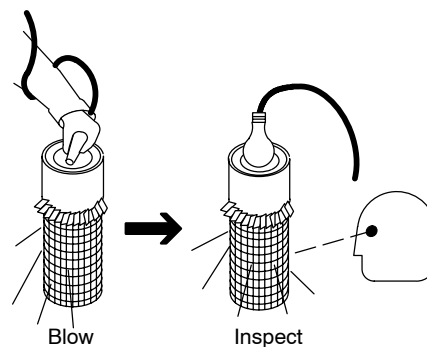
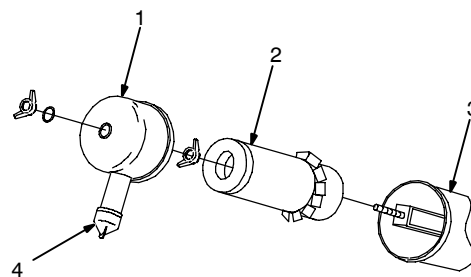
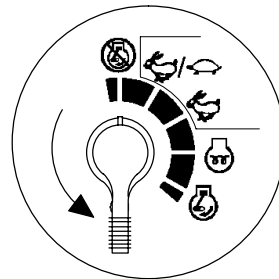

7.6 Adjusting Engine Speed

Ref. ST-159 215-E



After tuning engine, check engine speeds with a tachometer (see table for no load speeds). If necessary, adjust speeds as follows:

Start engine and run until warm.

Idle Speed Adjustment

Turn Engine Control switch to Run/Idle position.

- 1 Idle Speed Lock Nut
- 2 Idle Speed Screw

Loosen nut. Turn screw until engine runs at idle speed. Tighten nut.

Weld/Power Speed Adjustment

Turn Engine Control switch to Run position.

- 3 Weld/Power Speed Lock Nut
- 4 Weld/Power Speed Screw
- 5 Linkage Lock Nut
- 6 Linkage

Loosen nut and turn linkage until engine runs 50 rpm above specified weld/power speed. Tighten linkage lock nut.

Turn weld/power speed screw until engine runs at weld/power speed. Tighten nut.

▲ Stop engine.

Shutdown Adjustment



 Shutdown mechanism normally does not require adjustment unless tampered with.

- 7 Shutdown Linkage Lock Nuts
- 8 Shutdown Linkage Rod

Loosen nuts. Turn rod until measurement between swivels is 3 in (76 mm). Tighten nuts.

- 9 Shutdown Lever Lock Nut
- 10 Shutdown Lever Adjust Nut
- 11 Shutdown Lever Screw
- 12 Shutdown Lever

Loosen nuts. Back screw out and away from lever. Turn lever clockwise until lever hits internal stop. Tighten adjust nut until screw hits lever, then tighten adjust nut another 1-1/2 turns to bring lever off internal stop. Tighten nuts.

	
	3700 rpm
	2200 rpm

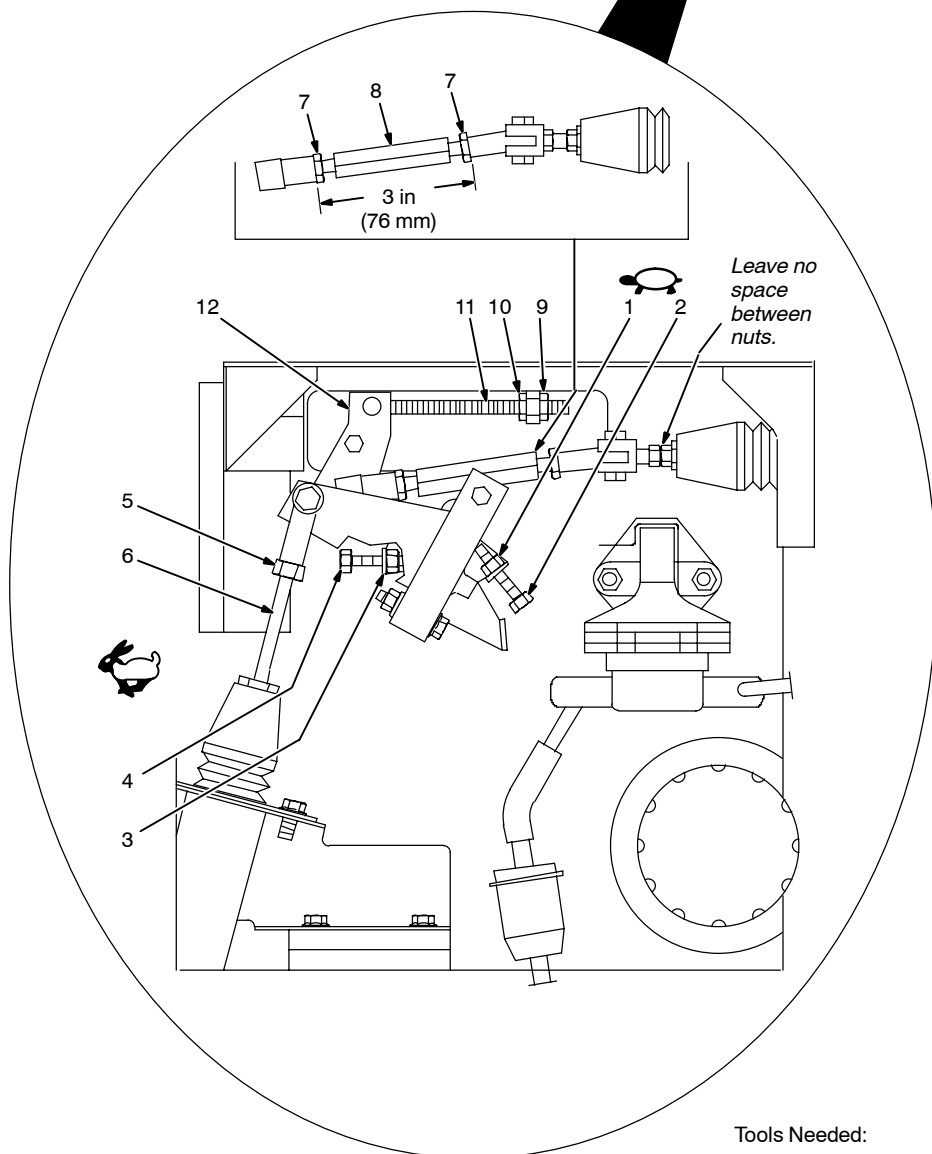
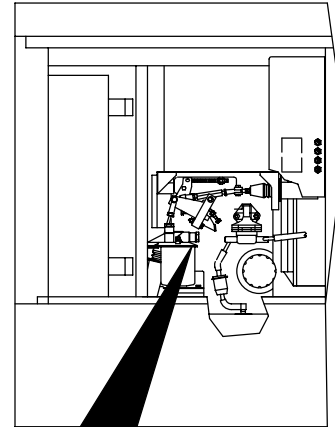

Tools Needed:

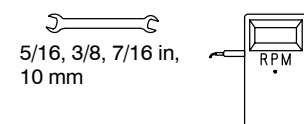

7.7 Overload Protection

Ref. ST-159 215-E / Ref. ST-158 936-D / Ref. St-175 918-C



▲ **Stop engine. If checking fuse, disconnect battery negative (-) cable.**

☞ *Press button to reset circuit breaker. If fuse or breaker continues to open, contact Factory Authorized Service Agent.*

Weld And Auxiliary Power Circuits

1 Fuse F2

F2 protects battery excitation circuit. If F2 opens, weld and auxiliary output stops.

2 Fuse F3

F3 protects generator excitation circuit. If F3 opens, weld and auxiliary power output is low.

Replace any open fuses. Reinstall panel before operating unit.

Remote Control Circuit

3 Circuit Breaker CB5

CB5 protects 24 volt ac output to Remote 14 receptacle RC1. If CB5 opens, RC1 24 volt output stops.

Engine Control Circuit

4 Circuit Breakers CB6, CB7, CB8, And CB9

CB6 protects fuel solenoid circuit. If CB6 opens, the engine does not start.

CB7 protects throttle solenoid circuit. If CB7 opens, the engine does not run at weld/power speed.

CB8 protects Engine Control switch and wiring harness. If CB8 opens, the engine does not crank.

CB9 protects optional glow plug system. If CB9 opens, the glow plug does not work.

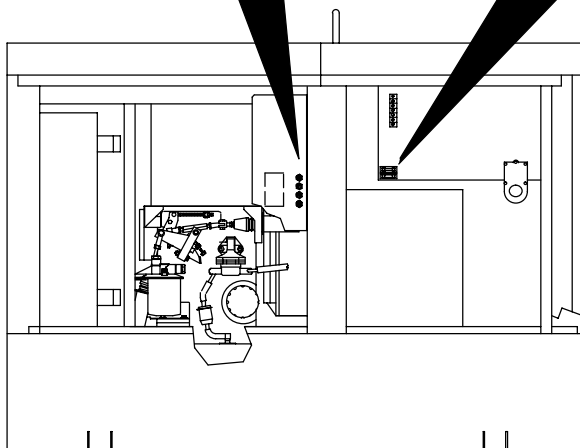
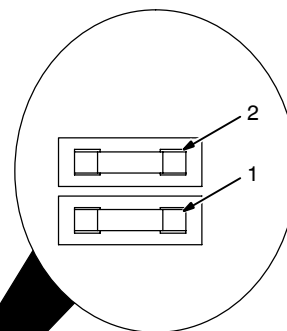
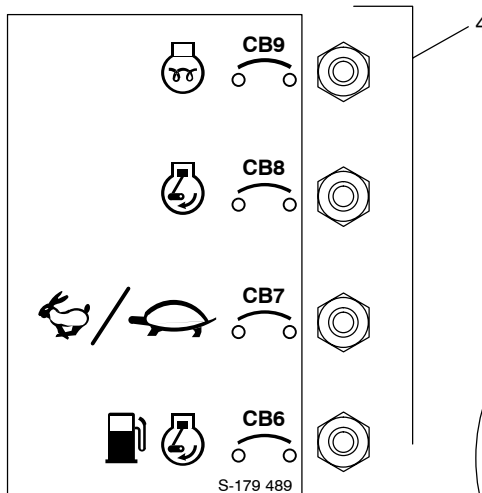
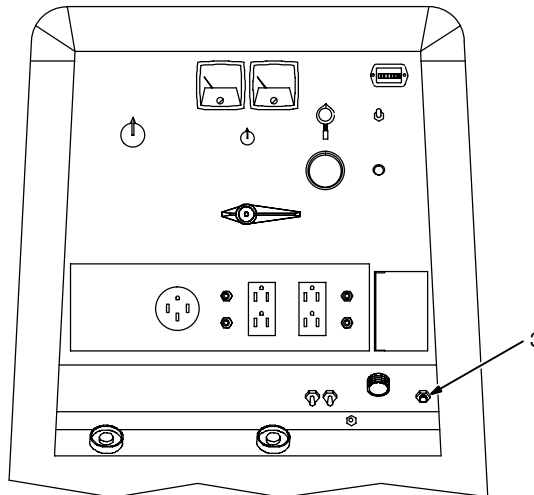
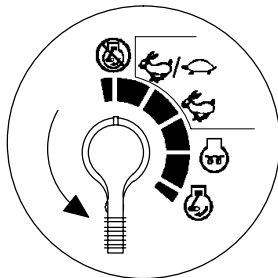

Tools Needed:

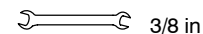
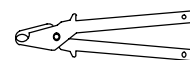

7.8 Servicing Optional Spark Arrestor

ST-801 154-B / Ref. ST-175 918-C

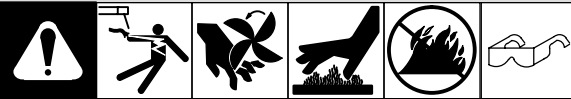

▲ Stop engine and let cool.

- 1 Spark Arrestor
- 2 Cleanout Plug

Remove plug and remove any dirt covering cleanout hole.

- 3 Exhaust Pipe

Start engine and run at idle speed to blow out cleanout hole. If nothing blows out of hole, briefly cover end of exhaust pipe with fireproof material.

▲ Stop engine and let cool.

Reinstall cleanout plug.

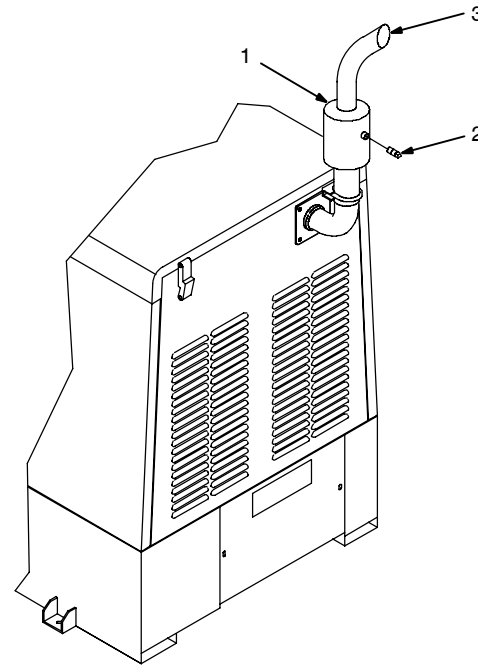
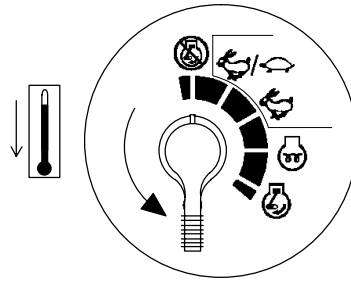

Tools Needed:

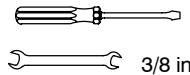

3/8 in

7.9 Welding Troubleshooting

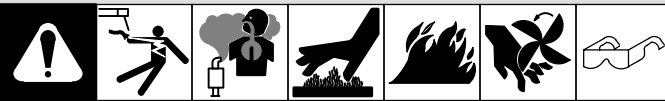

Trouble	Remedy
No weld output.	<p>Check control settings (see Section 5.1).</p> <p>Check fuses F2 and F3, and replace if necessary (see Section 7.7).</p> <p>Have Factory Authorized Service Agent check main rectifier and capacitor C5.</p> <p>Check and secure connections to Remote 14 Receptacle RC1.</p> <p>Place Output (Contactor) Control switch in On position, or place switch in Remote 14 position and connect remote contactor to Remote 14 receptacle RC1 (See Section 5.1).</p> <p>Have Factory Authorized Service Agent check brushes and slip rings, main rectifier, integrated rectifier SR3, capacitor C5, and circuit boards PC1 and PC6.</p>
Low weld output.	<p>Check control settings (see Section 5.1).</p> <p>Check fuses F2 and F3, and replace if open (see Section 7.7).</p> <p>Check engine speed, and adjust if necessary (see Section 7.6).</p> <p>Tune engine according to engine manual.</p> <p>Place Amperage Control switch in Panel position, or place switch in Remote 14 position and connect remote amperage control to Remote 14 receptacle RC1.</p> <p>Have Factory Authorized Service Agent check brushes and slip rings, main rectifier, integrated rectifier SR3, capacitor C5, Amperage Control R4, and circuit board PC6.</p>
High weld output.	<p>Check engine speed, and adjust if necessary (see Section 7.6).</p> <p>Have Factory Authorized Service Agent check main rectifier.</p>

Trouble	Remedy
Erratic weld output.	Clean and tighten weld output connections inside and outside unit.
	Use dry, properly-stored electrodes.
	Remove excessive coils from weld cables.
	Be sure connection to work piece is clean and tight.
	Have Factory Authorized Service Agent check brushes, slip rings, main rectifier, integrated rectifier SR3, capacitor C5, and circuit board PC6.
No 24 volt ac output at Remote 14 receptacle RC1.	Reset circuit breaker CB5 (see Section 7.7).

7.10 Auxiliary Power Troubleshooting



Trouble	Remedy
No output at auxiliary power receptacles.	Disconnect equipment from receptacles during start-up.
	Reset circuit breakers (see Section 6).
	Reset ground fault circuit interrupter GFCI1 (see Section 6).
	Check fuses F2 and F3, and replace if necessary (see Section 7.7).
	Check receptacles for continuity and proper connections. Replace receptacle(s) if necessary.
Low output at receptacles.	Have Factory Authorized Service Agent check brushes, slip rings, relay CR5, and relay CR6.
	Check fuses F2 and F3, and replace if necessary (see Section 7.7).
	Check engine speed, and adjust if necessary (see Section 7.6).
	Tune-up engine according to engine manual.
High output at receptacles.	Have Factory Authorized Service Agent check brushes, slip rings, and integrated rectifier SR3.
	Check engine speed, and adjust if necessary (see Section 7.6).
Erratic output at receptacles.	Check receptacle wiring and connections.
	Have Factory Authorized Service Agent check brushes, slip rings, and integrated rectifier SR3.

7.11 Engine Troubleshooting



Trouble	Remedy
Engine does not crank.	Reset circuit breaker CB8 (see Section 7.7).
	Check battery, and replace if necessary.
	Check plug PLG8 connection.
	Check Engine Control switch S1 and replace if necessary.
	Check engine charging and starting systems according to engine service manual.

Trouble	Remedy
Engine cranks but does not start.	Check fuel level (see Section 4.3).
	Reset circuit breaker CB6 (see Section 7.7).
	If equipped with glow plug (optional), reset circuit breaker CB9 (see Section 7.7).
	Check Engine Control switch S1, and replace if necessary.
	Check low oil pressure shutdown switch S2, and replace if necessary.
	See engine manual.
	Have Factory Authorized Service Agent check fuel solenoid, and fuel solenoid control module.
Engine starts, but stops when Engine Control switch is released.	Check oil level. Engine stops if oil pressure gets too low (see Section 4.3).
High Or Low Engine Speed.	Check engine speed, and adjust if necessary (see Section 7.6).
Engine does not return to idle speed.	Have Factory Authorized Service Agent check throttle solenoid TS1, relay CR4, and idle control module.
Engine idles but does not reach weld speed.	Reset circuit breaker CB7 (see Section 7.7).
	Move Idle Lock switch to Run/Idle position.
	Have Factory Authorized Service Agent check throttle solenoid TS1, relay CR4, throttle solenoid control module, and idle control module.
Engine uses oil during run-in period; wetstacking occurs.	Dry engine (see Section 9 and engine manual).
Battery discharges between uses.	Clean battery, terminals, and posts with baking soda and water solution; rinse with clear water.
	Periodically recharge battery (approximately every 3 months).
	Check engine charging system according to engine service manual.
	Check Engine Control switch S1, and replace if necessary.
	Replace battery.
Engine stopped and cannot be restarted.	Check fuel level (see Section 4.3).
	Reset circuit breaker CB6 (see Section 7.7).
	Reset circuit breaker CB8 (see Section 7.7).
	Check oil level. Engine stops if oil pressure gets too low (see Section 4.3).
	See engine manual.

8. Electrical Diagram

8.1 Circuit Diagram for Welding Generator

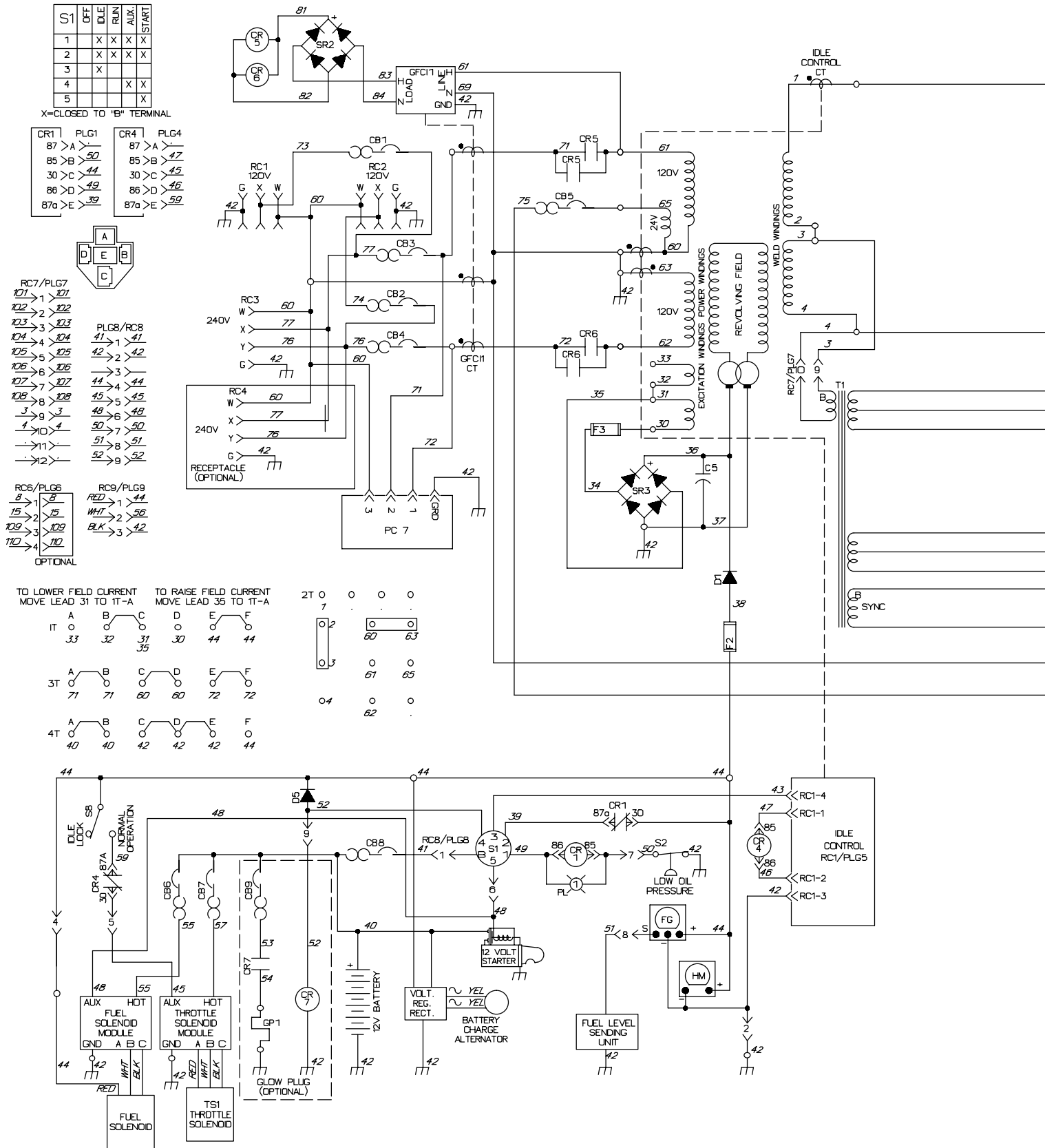

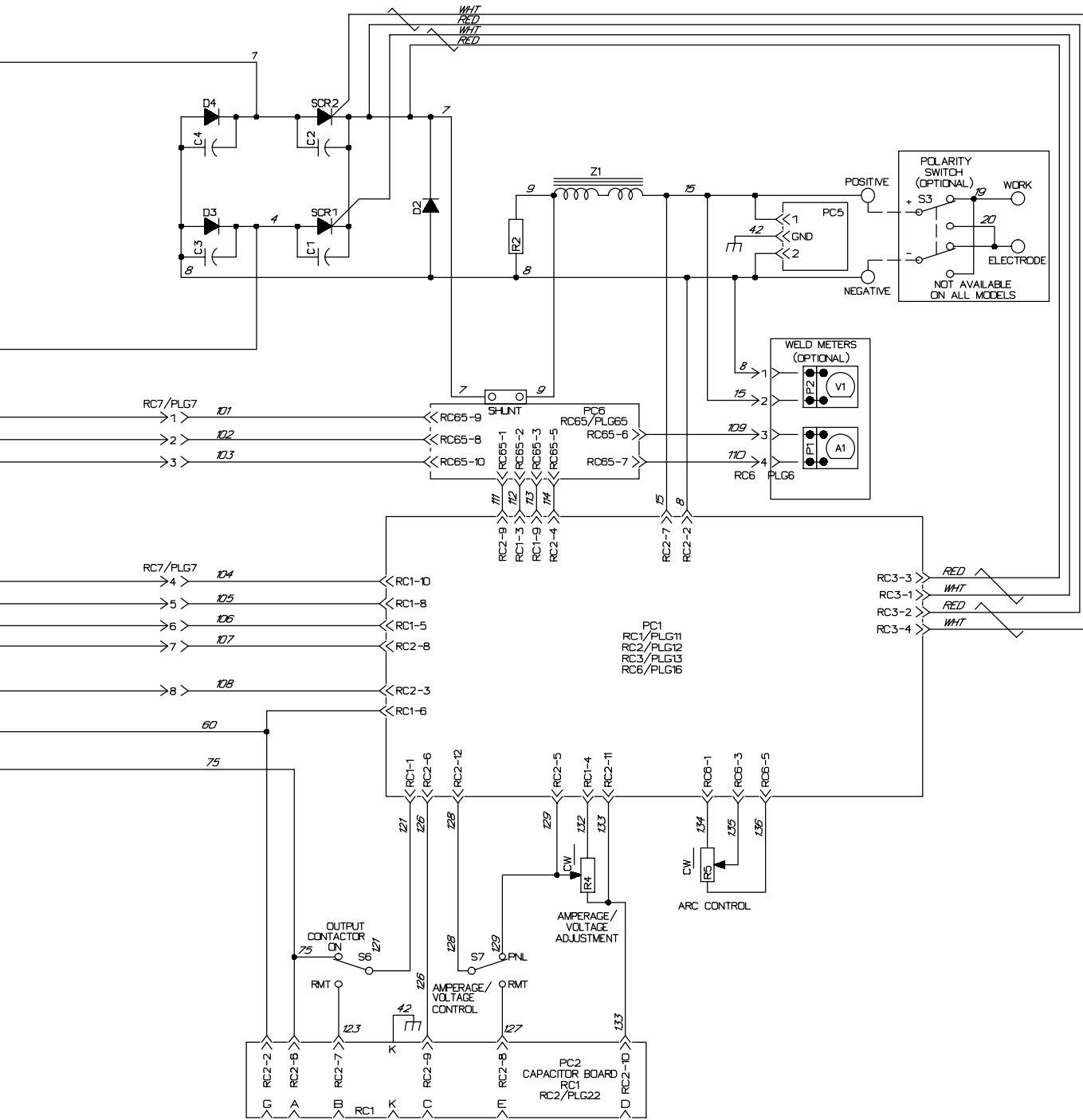

9. Run-In Procedure

9.1 Wetstacking

runin2 12/96

▲ **Heavy loading during first 50 hours will damage engine. Keep load less than 225A (weld) or 7 kVA (power) for first 50 hours.**

☞ *Do not idle engine longer than necessary. Piston rings seat faster if engine runs at weld/power rpm, and the welding generator is kept loaded during run-in.*

- 1 Welding Generator
- 2 Engine Exhaust Pipe

Wetstacking is unburned fuel and oil in the exhaust pipe and occurs during run-in if the engine is run too long at light load or idle rpm.

If exhaust pipe is coated with a wet, black, tar-like substance, dry the engine using one of the following run-in procedures.

See the engine manual for additional engine run-in information.

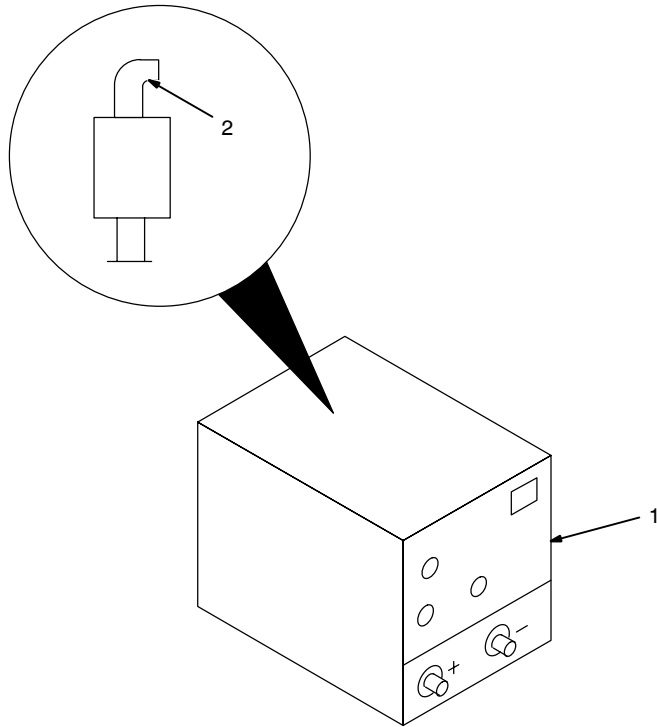

9.2 Run-In Procedure Using Load Bank

S-0683



- ▲ **Stop engine.**
- ▲ **Do not touch hot exhaust pipe, engine parts, or load bank/grid.**
- ▲ **Keep exhaust and pipe away from flammables.**

1 Load Bank

Turn all load bank switches Off. If needed, connect load bank to 115 volts ac wall receptacle or generator auxiliary power receptacle.

2 Welding Generator

Set Amperage control at min.

3 Weld Cables

Connect load bank to generator weld output terminals using proper size weld cables with correct connectors. Observe correct polarity.

Start engine and run for several minutes.

Set load bank switches and then adjust Amperage control so load and output are 180 A.

Check generator and load bank meters after first five minutes then every fifteen minutes to be sure generator is loaded properly.

 *Check oil level frequently during run-in; add oil if needed.*

After one hour (minimum), place Amperage control in minimum position, then turn off load bank to remove load. Run engine several minutes at no load.

- ▲ **Stop engine and let cool.**

4 Engine Exhaust Pipe

Repeat procedure if wetstacking is present.

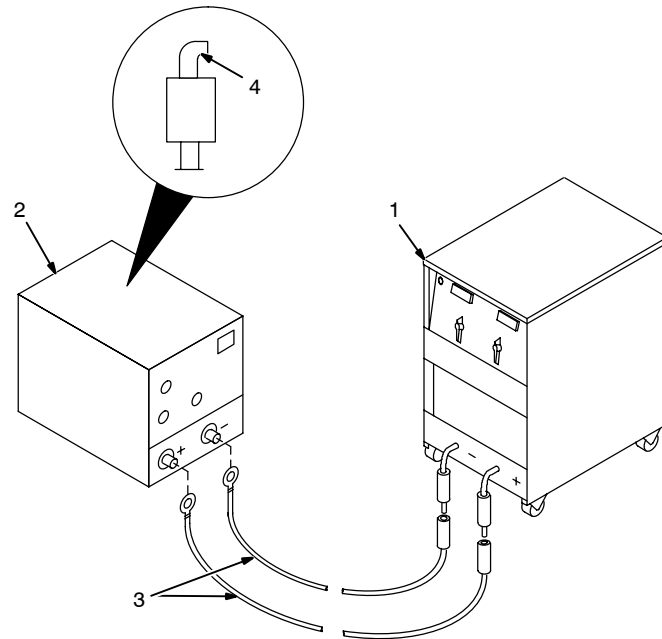

9.3 Run-In Procedure Using Resistance Grid

S-0684



▲ Stop engine.

▲ Do not touch hot exhaust pipe, engine parts, or load bank/ grid.

▲ Keep exhaust and pipe away from flammables.

1 Resistance Grid

Use grid sized for generator rated output.

Turn Off grid.

2 Welding Generator

Set Amperage control at min.

3 Weld Cables

Connect grid to generator weld output terminals using proper size weld cables with correct connectors (polarity is not important).

4 Voltmeter

5 Clamp-On Ammeter

Connect voltmeter and ammeter as shown, if not provided on generator.

Start engine and run for several minutes.

Set grid switches and then adjust Amperage control so load and output are 180 A.

Check generator and meters after first five minutes then every fifteen minutes to be sure generator is loaded properly.

 Check oil level frequently during run-in; add oil if needed.

After one hour (minimum), place Amperage control in minimum position, then shut down grid to remove load. Run engine several minutes at no load.

▲ Stop engine and let cool.

6 Engine Exhaust Pipe

Repeat procedure if wetstacking is present.

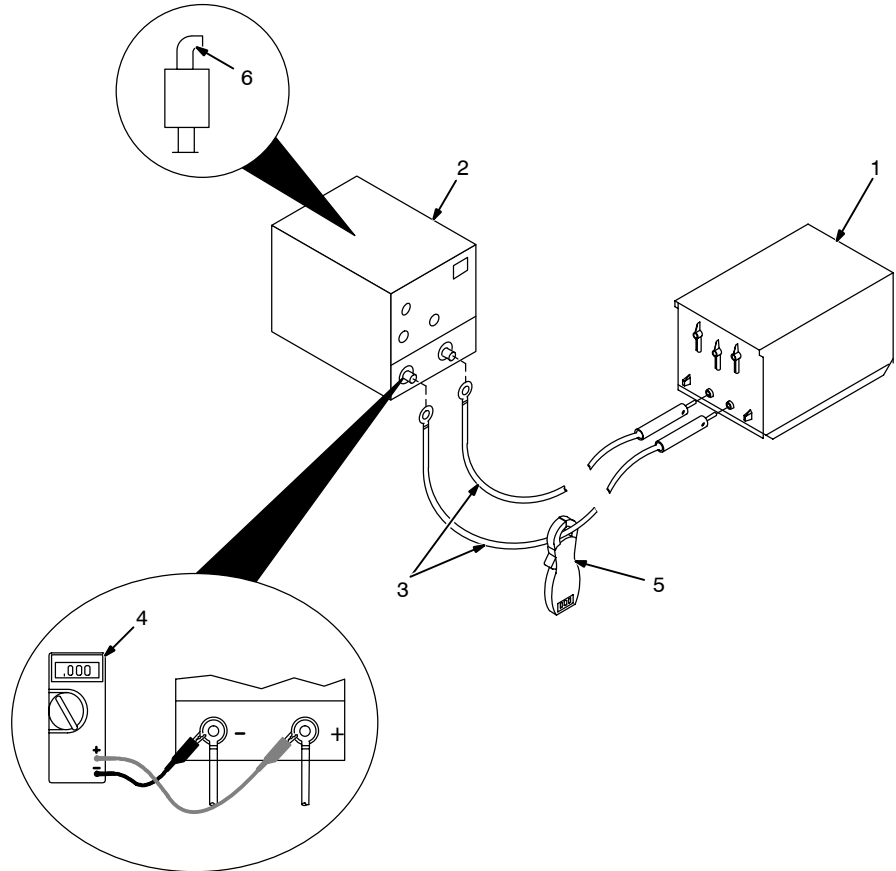

10. Auxiliary Power Guidelines

10.1 Selecting Equipment



aux_pwr 12/96 – Ref. ST-159 730 / ST-800 577

- 1 Auxiliary Power Receptacles – Neutral Bonded To Frame
- 2 3-Prong Plug From Case Grounded Equipment
- 3 2-Prong Plug From Double Insulated Equipment

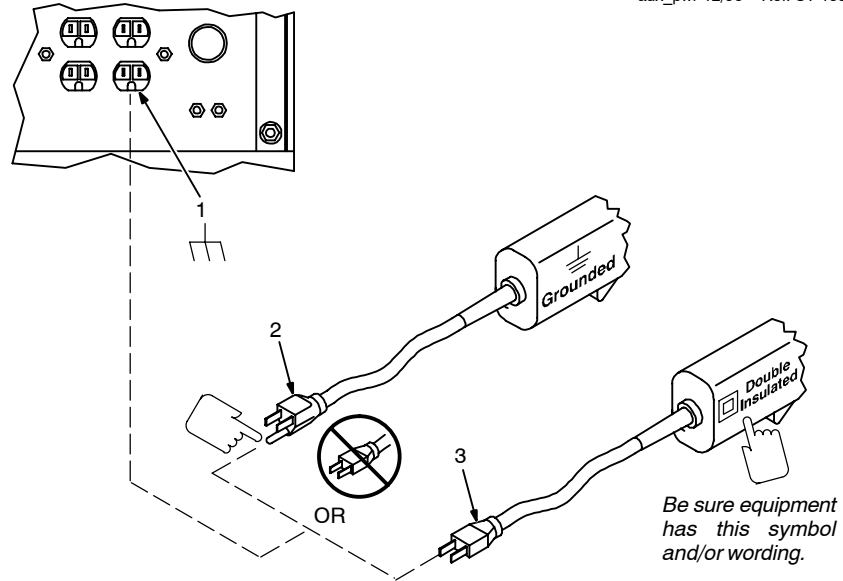

10.2 Grounding Generator to Truck or Trailer Frame



S-0854

- 1 Generator Base
- 2 Metal Vehicle Frame
- 3 Equipment Grounding Terminal
- 4 Grounding Cable

Use #10 AWG or larger insulated copper wire.

▲ If unit does not have GFCI receptacles, use GFCI-protected extension cord.

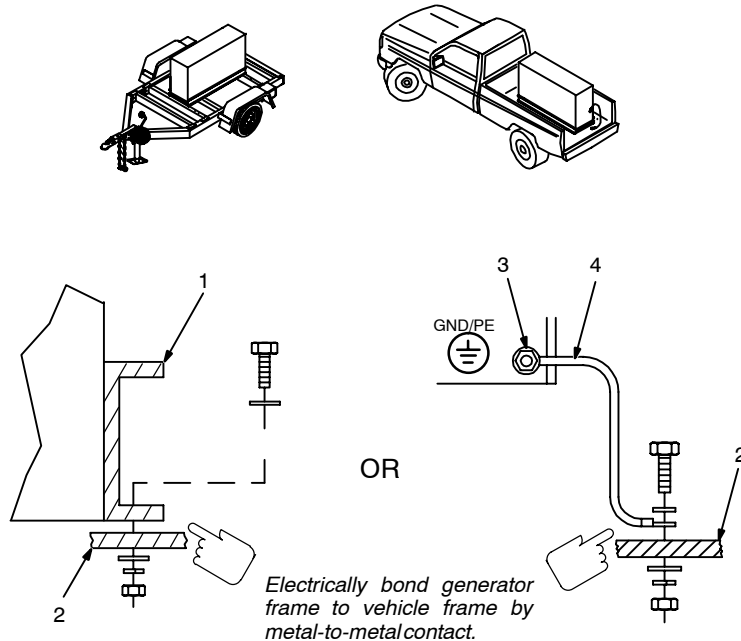

10.3 Grounding When Supplying Building Systems

ST-800 576-B

1 Equipment Grounding Terminal

2 Grounding Cable

Use #10 AWG or larger insulated copper wire.

3 Ground Device

▲ **Ground generator to system earth ground if supplying power to a premises (home, shop, farm) wiring system.**

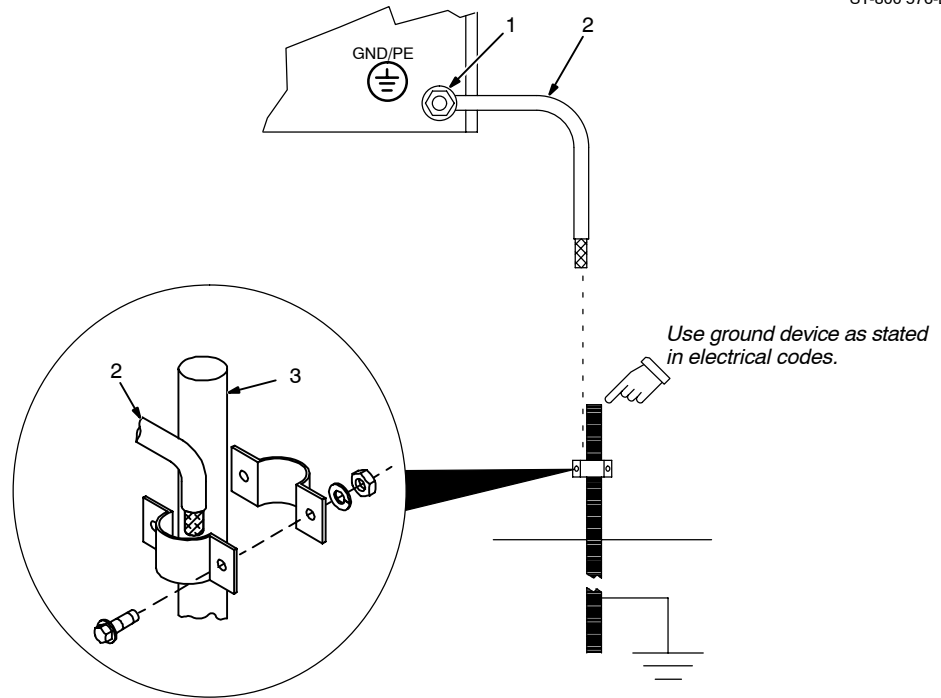

10.4 How Much Power Does Equipment Require?

S-0623

1 Resistive Load

A light bulb is a resistive load and requires a constant amount of power.

2 Non-Resistive Load

Equipment with a motor is a non-resistive load and requires approximately six times more power while starting the motor than when running (see Section 10.8).

3 Rating Data

Rating shows volts and amperes, or watts required to run equipment.

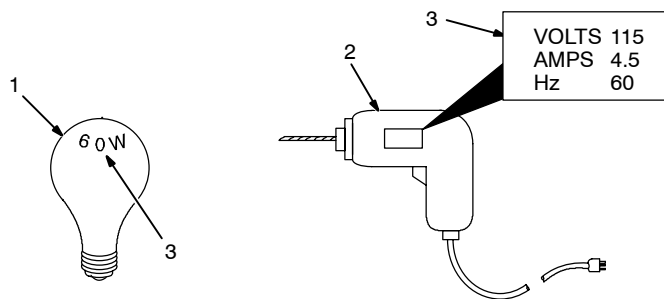

$$\text{AMPERES} \times \text{VOLTS} = \text{WATTS}$$

EXAMPLE 1: If a drill uses 4.5 amperes at 115 volts, calculate its running power requirement in watts.

$$4.5 \text{ A} \times 115 \text{ V} = 520 \text{ W}$$

The load applied by the drill is 520 watts.

EXAMPLE 2: If three 200 watt flood lamps are used with the drill from Example 1, add the individual loads to calculate total load.

$$(200 \text{ W} + 200 \text{ W} + 200 \text{ W}) + 520 \text{ W} = 1120 \text{ W}$$

The total load applied by the three flood lamps and drill is 1120 watts.

10.5 Approximate Power Requirements for Industrial Motors

Industrial Motors	Rating	Starting Watts	Running Watts
Split Phase	1/8 HP	800	300
	1/6 HP	1225	500
	1/4 HP	1600	600
	1/3 HP	2100	700
	1/2 HP	3175	875
Capacitor Start-Induction Run	1/3 HP	2020	720
	1/2 HP	3075	975
	3/4 HP	4500	1400
	1 HP	6100	1600
	1-1/2 HP	8200	2200
	2 HP	10550	2850
	3 HP	15900	3900
Capacitor Start-Capacitor Run	5 HP	23300	6800
	1-1/2 HP	8100	2000
	5 HP	23300	6000
	7-1/2 HP	35000	8000
Fan Duty	10 HP	46700	10700
	1/8 HP	1000	400
	1/6 HP	1400	550
	1/4 HP	1850	650
	1/3 HP	2400	800
	1/2 HP	3500	1100

10.6 Approximate Power Requirements for Farm/Home Equipment

Farm/Home Equipment	Rating	Starting Watts	Running Watts
Stock Tank De-Icer		1000	1000
Grain Cleaner	1/4 HP	1650	650
Portable Conveyor	1/2 HP	3400	1000
Grain Elevator	3/4 HP	4400	1400
Milk Cooler		2900	1100
Milker (Vacuum Pump)	2 HP	10500	2800
FARM DUTY MOTORS	1/3 HP	1720	720
Std. (e.g. Conveyors,	1/2 HP	2575	975
Feed Augers, Air	3/4 HP	4500	1400
Compressors)	1 HP	6100	1600
	1-1/2 HP	8200	2200
	2 HP	10550	2850
	3 HP	15900	3900
	5 HP	23300	6800
High Torque (e.g. Barn	1-1/2 HP	8100	2000
Cleaners, Silo Unloaders,	5 HP	23300	6000
Silo Hoists, Bunk Feeders)	7-1/2 HP	35000	8000
	10 HP	46700	10700
3-1/2 cu. ft. Mixer	1/2 HP	3300	1000
High Pressure 1.8 Gal/Min	500 PSI	3150	950
Washer 2 gal/min	550 PSI	4500	1400
2 gal/min	700 PSI	6100	1600
Refrigerator or Freezer		3100	800
Shallow Well Pump	1/3 HP	2150	750
	1/2 HP	3100	1000
Sump Pump	1/3 HP	2100	800
	1/2 HP	3200	1050

10.7 Approximate Power Requirements for Contractor Equipment

Contractor	Rating	Starting Watts	Running Watts
Hand Drill	1/4 in	350	350
	3/8 in	400	400
	1/2 in	600	600
Circular Saw	6-1/2 in	500	500
	7-1/4 in	900	900
	8-1/4 in	1400	1400
Table Saw	9 in	4500	1500
	10 in	6300	1800
Band Saw	14 in	2500	1100
Bench Grinder	6 in	1720	720
	8 in	3900	1400
	10 in	5200	1600
Air Compressor	1/2 HP	3000	1000
	1 HP	6000	1500
	1-1/2 HP	8200	2200
	2 HP	10500	2800
Electric Chain Saw	1-1/2 HP, 12 in	1100	1100
	2 HP, 14 in	1100	1100
Electric Trimmer	Standard 9 in	350	350
	Heavy Duty 12 in	500	500
Electric Cultivator	1/3 HP	2100	700
Elec. Hedge Trimmer	18 in	400	400
Flood Lights	HID	125	100
	Metal Halide	313	250
	Mercury	1000	
	Sodium	1400	
Submersible Pump	Vapor	1250	1000
	400 gph	600	200
Centrifugal Pump	900 gph	900	500
Floor Polisher	3/4 HP, 16 in	4500	1400
	1 HP, 20 in	6100	1600
High Pressure Washer	1/2 HP	3150	950
	3/4 HP	4500	1400
	1 HP	6100	1600
55 gal Drum Mixer	1/4 HP	1900	700
Wet & Dry Vac	1.7 HP	900	900
	2-1/2 HP	1300	1300

10.8 Power Required to Start Motor

S-0624

- 1 Motor Start Code
- 2 Running Amperage
- 3 Motor HP
- 4 Motor Voltage

To find starting amperage:

Step 1: Find code and use table to find kVA/HP. If code is not listed, multiply running amperage by six to find starting amperage.

Step 2: Find Motor HP and Volts.

Step 3: Determine starting amperage (see example).

Welding generator amperage output must be at least twice the motor's running amperage.

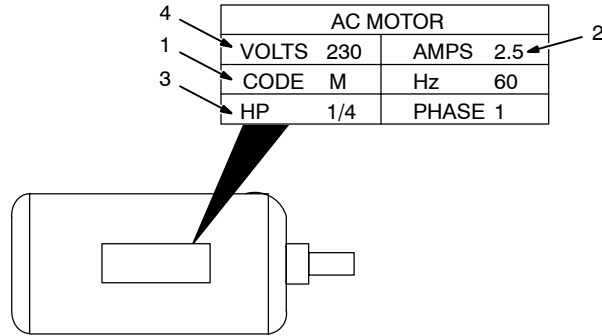

Single-Phase Induction Motor Starting Requirements

Motor Start Code	G	H	J	K	L	M	N	P
KVA/HP	6.3	7.1	8.0	9.0	10.0	11.2	12.5	14.0

$$\frac{\text{kVA/HP} \times \text{HP} \times 1000}{\text{VOLTS}} = \text{STARTING AMPERAGE}$$

EXAMPLE: Calculate the starting amperage required for a 230 V, 1/4 HP motor with a motor start code of M.

Volts = 230 HP = 1/4 Using Table, Code M results in kVA/HP = 11.2

$$\frac{11.2 \times 1/4 \times 1000}{230} = 12.2 \text{ A} \quad \text{Starting the motor requires 12.2 amperes.}$$

10.9 How Much Power Can Generator Supply?

Ref. ST-800 396-A / S-0625

- 1 Limit Load To 90% Of Generator Output

Always start non-resistive (motor) loads in order from largest to smallest, and add resistive loads last.

- 2 5 Second Rule

If motor does not start within 5 seconds, turn off power to prevent motor damage. Motor requires more power than generator can supply.

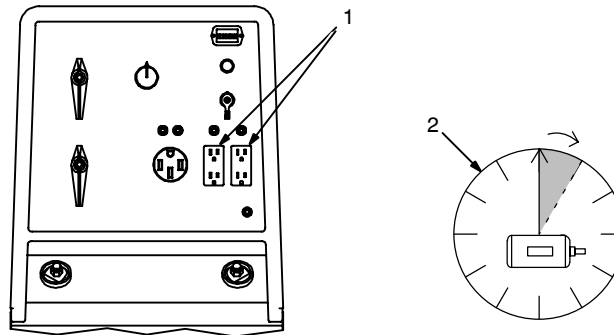

10.10 Typical Connections to Supply Standby Power

S-0405-A



Customer-supplied equipment is required if generator is to supply standby power during emergencies or power outages.

- 1 Power Company Service Meter
 - 2 Main and Branch Overcurrent Protection
 - 3 Double-Pole, Double-Throw Transfer Switch
- Obtain and install correct switch. Switch rating must be same as or greater than the branch overcurrent protection.
- 4 Circuit Breakers or Fused Disconnect Switch
- Obtain and install correct switch.
- 5 Extension Cord
- Select as shown in Section 10.11.
- 6 Generator Connections
- Connect terminals or plug of adequate amperage capacity to cord. Follow all applicable codes and safety practices.
- Turn off or unplug all equipment connected to generator before starting or stopping engine. When starting or stopping, the engine has low speed which causes low voltage and frequency.
- 7 Load Connections

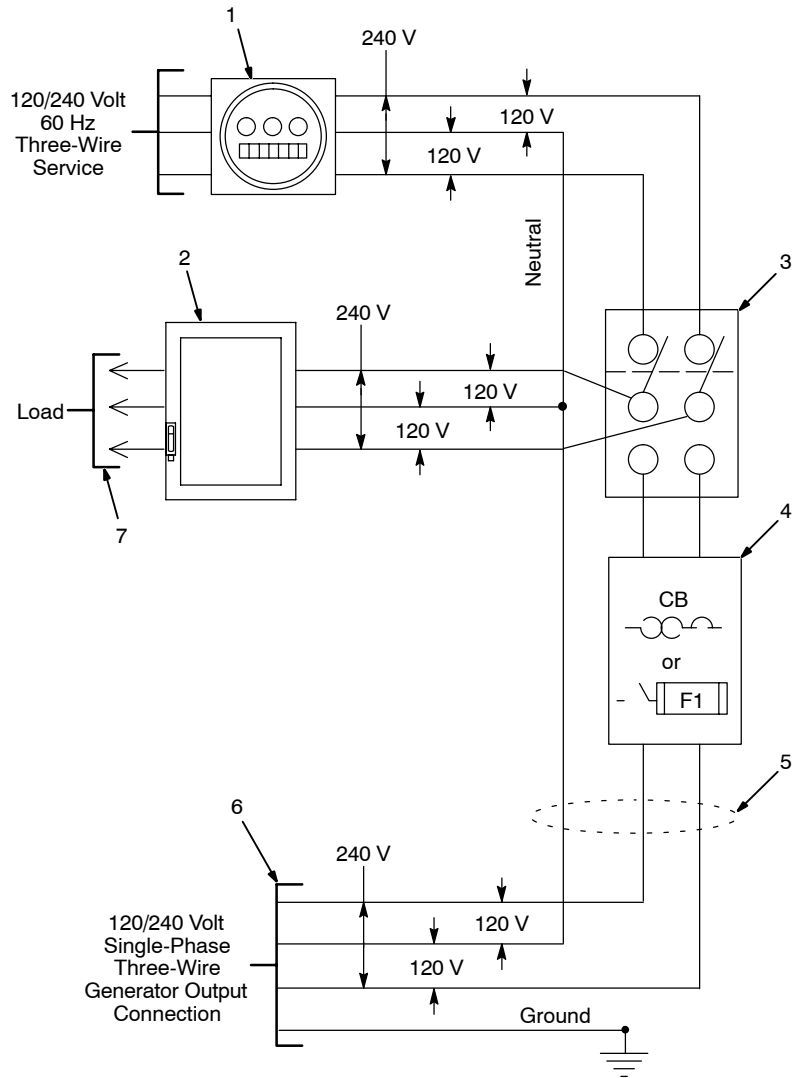

10.11 Selecting Extension Cord (Use Shortest Cord Possible)



Cord Lengths for 120 Volt Loads

▲ If unit does not have GFCI receptacles, use GFCI-protected extension cord.

Current (Amperes)	Load (Watts)	Maximum Allowable Cord Length in ft (m) for Conductor Size (AWG)*					
		4	6	8	10	12	14
5	600			350 (106)	225 (68)	137 (42)	100 (30)
7	840		400 (122)	250 (76)	150 (46)	100 (30)	62 (19)
10	1200	400 (122)	275 (84)	175 (53)	112 (34)	62 (19)	50 (15)
15	1800	300 (91)	175 (53)	112 (34)	75 (23)	37 (11)	30 (9)
20	2400	225 (68)	137 (42)	87 (26)	50 (15)	30 (9)	
25	3000	175 (53)	112 (34)	62 (19)	37 (11)		
30	3600	150 (46)	87 (26)	50 (15)	37 (11)		
35	4200	125 (38)	75 (23)	50 (15)			
40	4800	112 (34)	62 (19)	37 (11)			
45	5400	100 (30)	62 (19)				
50	6000	87 (26)	50 (15)				

*Conductor size is based on maximum 2% voltage drop

Cord Lengths for 240 Volt Loads

▲ If unit does not have GFCI receptacles, use GFCI-protected extension cord.

Current (Amperes)	Load (Watts)	Maximum Allowable Cord Length in ft (m) for Conductor Size (AWG)*					
		4	6	8	10	12	14
5	1200			700 (213)	450 (137)	225 (68)	200 (61)
7	1680		800 (244)	500 (152)	300 (91)	200 (61)	125 (38)
10	2400	800 (244)	550 (168)	350 (107)	225 (69)	125 (38)	100 (31)
15	3600	600 (183)	350 (107)	225 (69)	150 (46)	75 (23)	60 (18)
20	4800	450 (137)	275 (84)	175 (53)	100 (31)	60 (18)	
25	6000	350 (107)	225 (69)	125 (38)	75 (23)		
30	7000	300 (91)	175 (53)	100 (31)	75 (23)		
35	8400	250 (76)	150 (46)	100 (31)			
40	9600	225 (69)	125 (38)	75 (23)			
45	10,800	200 (61)	125 (38)				
50	12,000	175 (53)	100 (31)				

*Conductor size is based on maximum 2% voltage drop

11. Parts List

11.1 Main Assembly

 Hardware is common and not available unless listed.

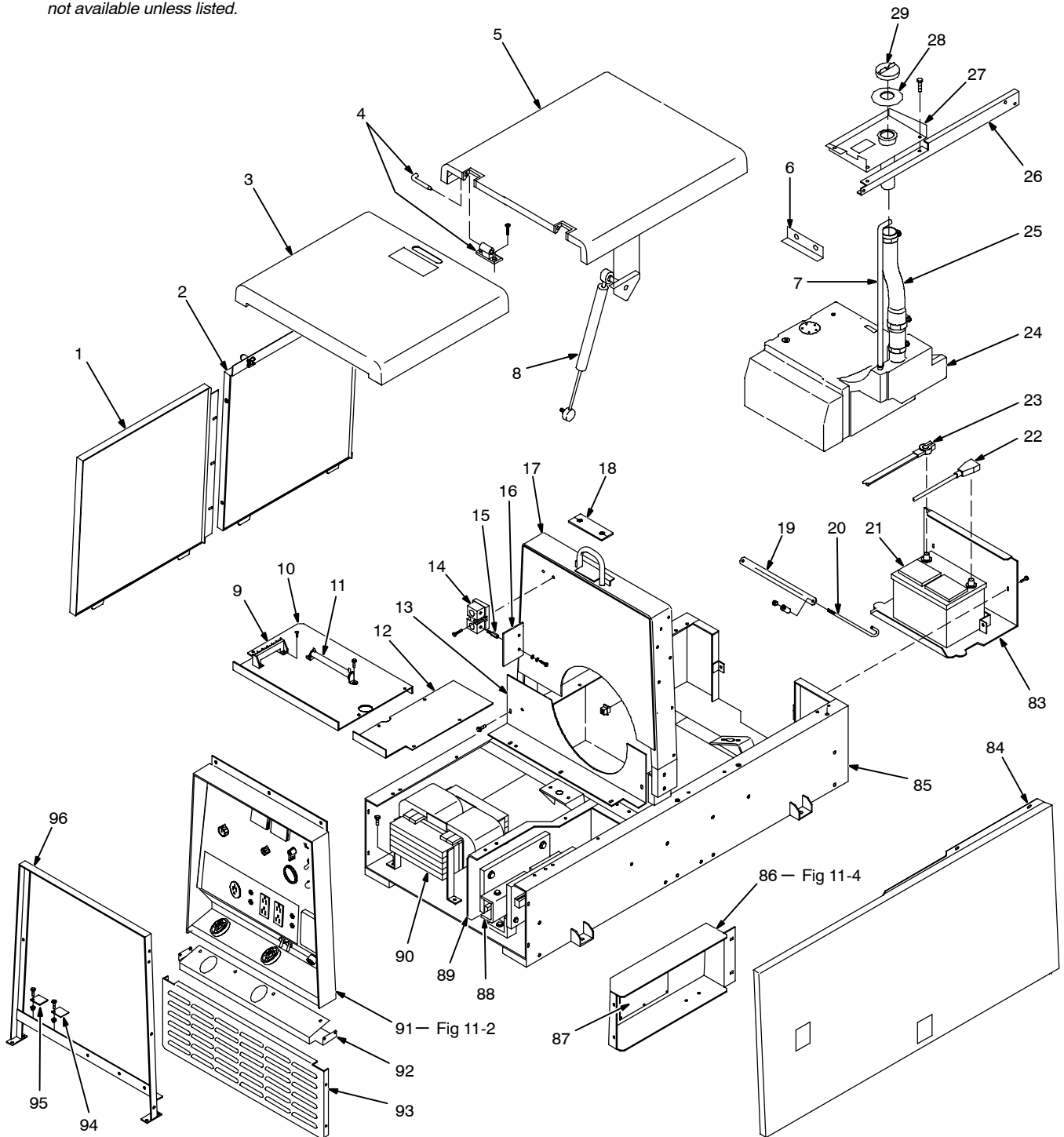

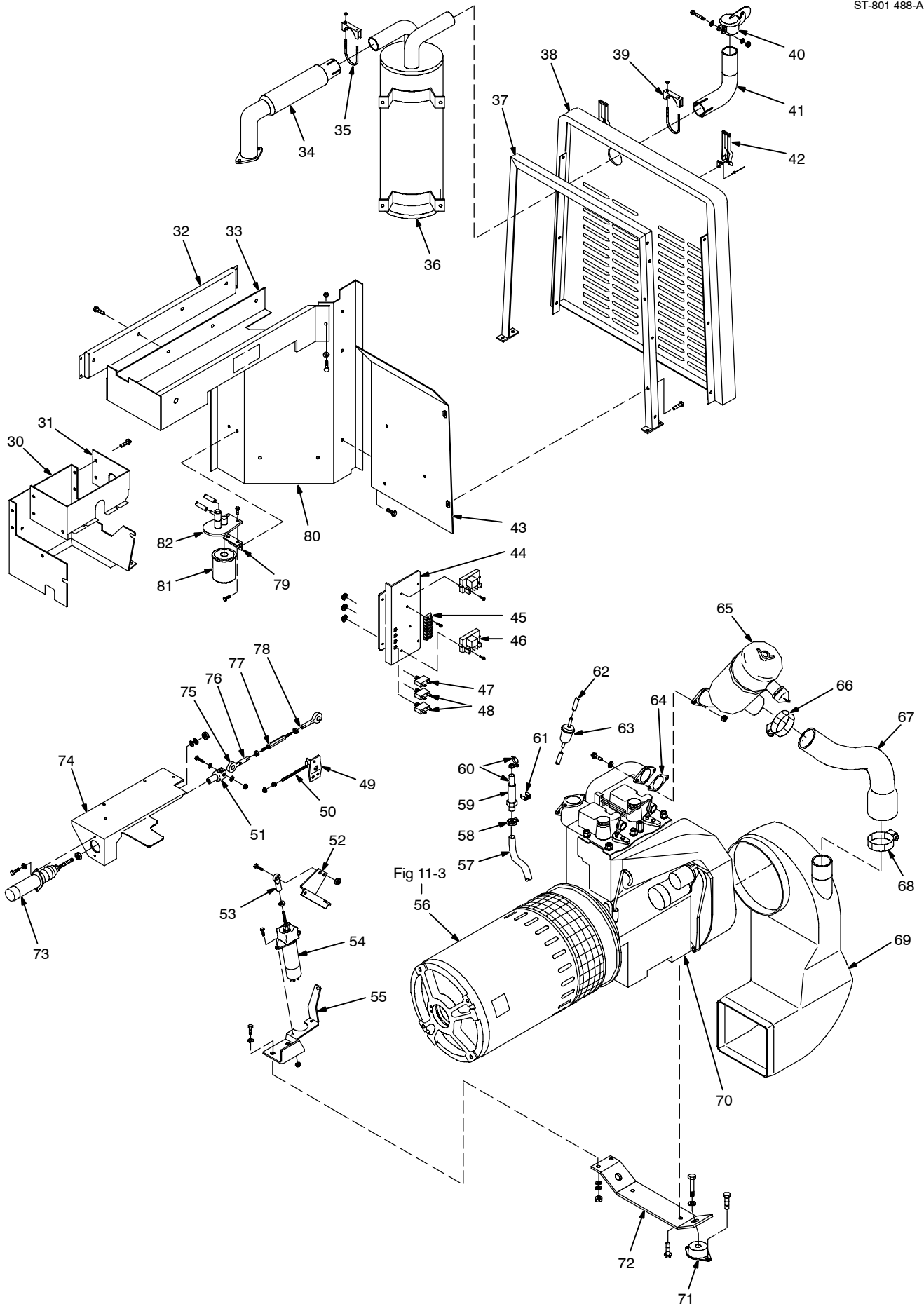

11.1 (Continued)

Item No.	Dia. Mkgs.	Part No.	Description	Quantity
1		+163 828	PANEL, side LH	1
2		164 507	PANEL, side LH rear	1
		171 053	SPRING, latch w/knob	2
3		+163 958	COVER, generator	1
		176 104	LABEL, warning falling equipment	1
4		165 839	HINGE, concealed	2
5		167 340	COVER, engine	1
6		167 280	ANGLE, hold down fuel tank	1
7		107 816	HOSE, SAE .250 ID x .500 OD (order by ft)	2ft
8		172 295	GAS, spring	1
		172 297	BRACKET, flat mtg spring	1
		172 296	BALL GAS SPRING, stud	1
9	3T	172 661	BLOCK, stud connection	1
		173 734	LINK, jumper	3
10		166 215	COVER, stabilizer	1
		004 214	BUSHING, snap-in nyl 1.625 ID x 2.000mtg hole	1
11	R2	128 862	RESISTOR, WW adj 375W 50 ohm	1
12		166 214	COVER, rectifier	1
13		165 840	FIREWALL, bottom	1
		162 451	FIREWALL, top	1
14	Shunt	030 080	SHUNT, meter	1
15		109 830	STAND-OFF, No. 8-32 x .250	2
16	PC6	132 495	CIRCUIT CARD, shunt	1
17		162 636	UPRIGHT, base center	1
18		157 026	GASKET, lift eye	1
19		172 133	HOLD DOWN, battery	1
20		172 134	BOLT, J stl .250-20 x 9.500	2
21		167 677	BATTERY, stor 12V 430crk 75RSV	1
		108 081	TERMINAL PROTECTORS, battery post	2
22		082 316	CABLE, bat pos	1
		114 923	BOOT, insulator term post red	1
23		179 964	CABLE, bat neg	1
24		164 871	TANK, fuel 12gal (consisting of)	1
		172 373	SENDER, fuel gauge	1
		172 371	FITTING, stand pipe hose .250 x 8.875 lg	1
		172 372	FITTING, hose stl barbed M 1/4tbg	1
		124 253	BUSHING, tank fuel	1
25		171 348	HOSE ASSEMBLY, fuel tank	1
		089 120	CLAMP, hose .375-.450 slfittng green	1
		084 173	CLAMP, hose .460-.545 slfittng	5
26		165 355	BRACKET, brace back RH	1
27		165 354	PAN, fuel splash	1
		176 103	LABEL, use diesel fuel only	1
28		107 343	GROMMET, rbr neck filler	1
29		015 603	CAP, tank fuel	1
30		166 723	ENCLOSURE, sides lower manifold	1
31		166 638	ENCLOSURE, sides upper manifold	1
32		164 552	BRACKET, brace back LH	1
		176 109	LABEL, caution using either	1
33		166 634	DUCT, hot air	1
34		144 802	PIPE, exhaust flexible	1
		179 646	GASKET, exhaust manifold	1
35		010 875	CLAMP, muffler 2.000	1
36		142 065	MUFFLER, exhaust	1
37		162 448	UPRIGHT, base rear	1
38		164 318	PANEL, rear	1
		176 230	LABEL, hot exhaust parts do not touch	1
39		109 591	CLAMP, muffler 1.750	1
40		603 767	CAP, weather No. 3	1

11.1 (Continued)

Item No.	Dia. Mkgs.	Part No.	Description	Quantity
41		173 931	PIPE, exhaust elbow	1
42		167 313	LATCH, elastic draw	2
43		166 722	BAFFLE, rear panel	1
44		173 366	PANEL, mtg components	1
45	4T	174 901	BLOCK, term 30A 6P	1
46		178 913	SOLENOID, module control	2
		♦043 138	COLD WEATHER DIESEL STARTING, (consisting of)	1
	CB9	147 658	CIRCUIT BREAKER, man reset 1P 30A 250VAC	1
	GP1	164 938	GLOW PLUG, 12V 65A	1
	CR7	155 309	CONTACTOR, solenoid 12VDC	1
47	CB8	115 427	CIRCUIT BREAKER, man reset 1P 25A 250VAC	1
48	CB6,7	083 432	CIRCUIT BREAKER, man reset 1P 10A 250VAC	2
49		175 897	LEVER, shutdown	1
50		170 438	SCREW, spot weld .250-20 x 3.000	1
51		127 648	CLEVIS, shutdown	1
52		172 375	LEVER, throttle	1
53		127 994	BALL JOINT, .250-20	1
54	TS1	180 598	SOLENOID, throttle (consisting of)	1
		180 751	WEAR BAND	1
55		172 374	BRACKET, mtg throttle solenoid	1
56		Fig 11.3	GENERATOR	1
57			HOSE, oil drain (included w/engine)	1
58		099 542	CLAMP, hose .583-.688clp dia	1
59		176 166	FITTING, hose brs barbed fem 3/8tbg x 3/8NPT	1
60		165 271	VALVE, oil drain 3/8-18NPTF	1
61		176 244	SPRING CLIP, oil drain hose	1
62		107 816	HOSE, SAE .250 ID x .500 OD (order by ft)	1ft
63		*066 113	FILTER, fuel inline	1
64		177 975	GASKET, air cleaner	1
65		176 541	AIR CLEANER, intake (consisting of)	1
		*065 604	AIR ELEMENT	1
66		010 862	CLAMP, hose 1.562-2.500clp dia	1
67		176 467	HOSE, air cleaner	1
68		010 863	CLAMP, hose 1.125-3.000clp dia	3
69		154 639	HOUSING, blower	1
70		181 803	ENGINE, Deutz elec Ruggerini	1
71		166 094	MOUNT, engine vibration	3
72		166 093	BRACKET, mtg engine	1
73	FS1	182 110	SOLENOID, fuel	1
74		166 724	BRACKET, mtg solenoid	1
75		175 893	LINKAGE, spherical rod end 1/4-28 LH female	1
76		126 388	NUT, .250-28 LH	1
77		172 392	LINKAGE, engine auto shutdown	1
78		175 894	LINKAGE, spherical rod end 10-32 female w/stud	1
79		166 726	BRACKET, mtg fuel filter	1
80		166 635	ENCLOSURE, muffler	1
81		*066 893	FILTER, fuel element	1
82			BASE, fuel filter (see engine parts list)	1
83		+166 952	BATTERY BOX	1
		176 108	LABEL, warning battery explosion	1
84		+163 074	PANEL, side RH	1
		176 106	LABEL, warning moving parts	2
85		+162 429	BASE	1
		157 812	LABEL, engine maintenance	1
		176 105	LABEL, warning general precautionary	1
			LABEL, rating (48V optional receptacle)	1
86		Fig 11.4	CONTROL BOX w/COMPONENTS	1
87	PC1	182 891	CIRCUIT CARD, control main	1

11.1 (Continued)

Item No.	Dia. Mkgs.	Part No.	Description	Quantity
88		162 515	RECTIFIER, si diode (consisting of)	1
	C1,3	048 420	CAPACITOR, cer disc .01uf 1000VDC	2
	C2,4	106 641	CAPACITOR, cer disc .01uf 500VDC	2
	D1-3	037 957	DIODE, rect 275A 300V RP	3
	SCR1,2	162 516	THYRISTOR, SCR 300A 300V	2
		028 388	CLAMP, thyristor	2
89		162 442	PANEL, air duct	1
90		163 608	STABILIZER	1
91		Fig 11.2	PANEL, front w/components	1
92		164 126	TRIM, panel front bottom	1
93		167 658	PANEL, front lower	1
94	PC5	148 608	CIRCUIT CARD, filter HF	1
		141 690	GROMMET, scr No. 8/10 panel hole	4
95	PC7	181 261	CIRCUIT CARD, filter HF	1
96		162 447	UPRIGHT, base front	1
		172 804	HARNESS, wiring unit	1
		182 032	HARNESS, engine	1
		172 802	HARNESS, receptacle	1
		177 119	KIT, label	1
		137 180	CLAMP, stl cushion .875dia	1
		166 347	TRIM, cover corners front	2
		166 348	TRIM, cover corners rear	2
		168 071	CONNECTOR & SOCKETS	2
		148 439	CONNECTOR & SOCKETS	2
		158 720	CONNECTOR & SOCKETS	1
		165 688	CONNECTOR & SOCKETS	1
		168 847	CONNECTOR & SOCKETS	1
		168 809	CONNECTOR & SOCKETS	1
		164 899	CONNECTOR & SOCKETS	1

+When ordering a component originally displaying a precautionary label, the label should also be ordered.

◆Optional 043 139 Cold Weather Diesel Starting Kit.

*Recommended Spare Parts.

To maintain the factory original performance of your equipment, use only Manufacturer's Suggested Replacement Parts. Model and serial number required when ordering parts from your local distributor.

11.2 Panel, Front w/Components (Fig 11.1 Item 91)

Item No.	Dia. Mkgs.	Part No.	Description	Quantity
1	R4,5	072 623	POTENTIOMETER, CP plain rnd 1/T 2W 1K linear	2
2	S1	172 070	SWITCH, ignition 5posn	1
3		178 772	PANEL, front	1
4		◆169 331	SWITCH, polarity	1
5	S6-8	011 609	SWITCH, tgl SPDT 15A 125VAC	3
6	RC3	132 539	RECEPTACLE, str 3P4W 50A 125/250V flush mtg	1
6	RC3	◆◆173 423	RECEPTACLE, 3P 50A 125/250V twk	1
7	CB3,4	141 267	CIRCUIT BREAKER, man reset 1P 50A 250VAC	2
			PLATE, receptacle (order by model and serial number)	1
8	RC1,2	167 657	RECEPTACLE, str dx grd 2P3W 15A 125V	2
9	CB1,2	139 266	CIRCUIT BREAKER, man reset 1P 15A 250VAC	2
10	GFCI1	172 072	SENSOR, GFCI Test & Reset 50A 240V	1
11		154 022	COVER, receptacle GFCI	1
12	PC2	147 554	CIRCUIT CARD, connector/receptacle	1

11.2 (Continued)

ST-801 515-A

 Hardware is common and not available unless listed.

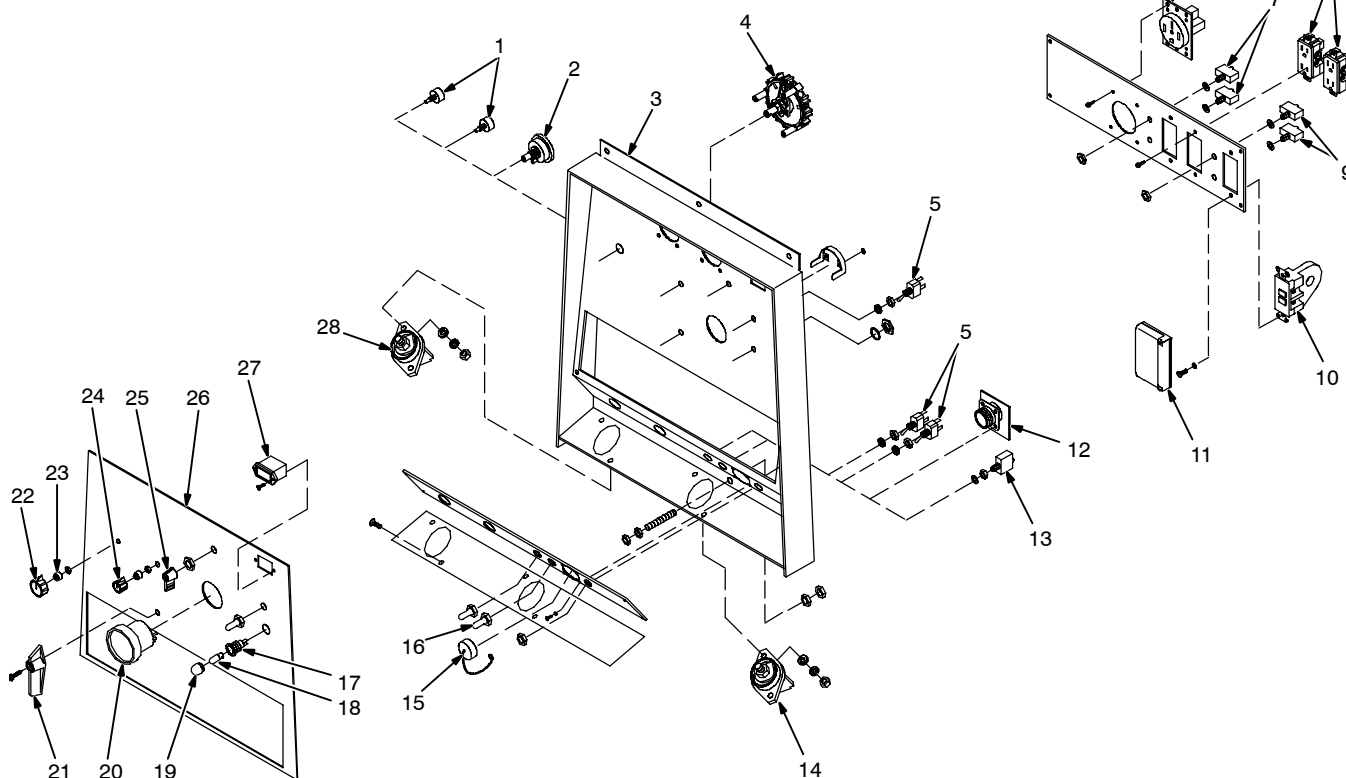

Item No.	Dia. Mkgs.	Part No.	Description	Quantity
... 13 ...	CB5	083 432	.. CIRCUIT BREAKER, man reset 1P 10A 250VAC	1
... 14 ...		039 046	.. TERMINAL, pwr output black	1
... 15 ...		170 391	.. CONNECTOR, circ protective cap size 20	1
... 16 ...		021 385	.. BOOT, tgl switch lever	3
... 17 ...		082 788	.. HOLDER, light ind	1
... 18 ...	PL1	*048 155	.. BULB, incand min 14V	1
... 19 ...		082 789	.. LENS, light ind red	1
... 20 ...	FG	118 066	.. GAUGE, fuel elec 12V	1
... 21 ...		◆148 956	.. HANDLE, switch	1
... 22 ...		097 924	.. KNOB, pointer	1
... 23 ...		072 590	.. LOCK, shaft pot	2
... 24 ...		097 922	.. KNOB, pointer	1
... 25 ...		119 014	.. LEVER, switch black	1
... 26 NAMEPLATE, (order by model and serial number)	1
... 27 ...	HM	145 247	.. METER, hour 12-24VDC	1
... 28 ...		039 047	.. TERMINAL, pwr output red	1
...		◆◆◆185 190	.. METER, amp dc 0-400	1
...		◆◆◆164 876	.. METER, volt dc 0-100	1

◆ Optional 042 924 Polarity Switch.

◆◆ Optional 043 253 Receptacle Kit, 120/250V 50A twk.

*Recommended Spare Parts.

◆◆◆ Optional 042 927 Meter Kit, volt and amp.

To maintain the factory original performance of your equipment, use only Manufacturer's Suggested Replacement Parts. Model and serial number required when ordering parts from your local distributor.

11.3 Generator (Fig 11.1 Item 56)

ST-801 289A

 Hardware is common and not available unless listed.

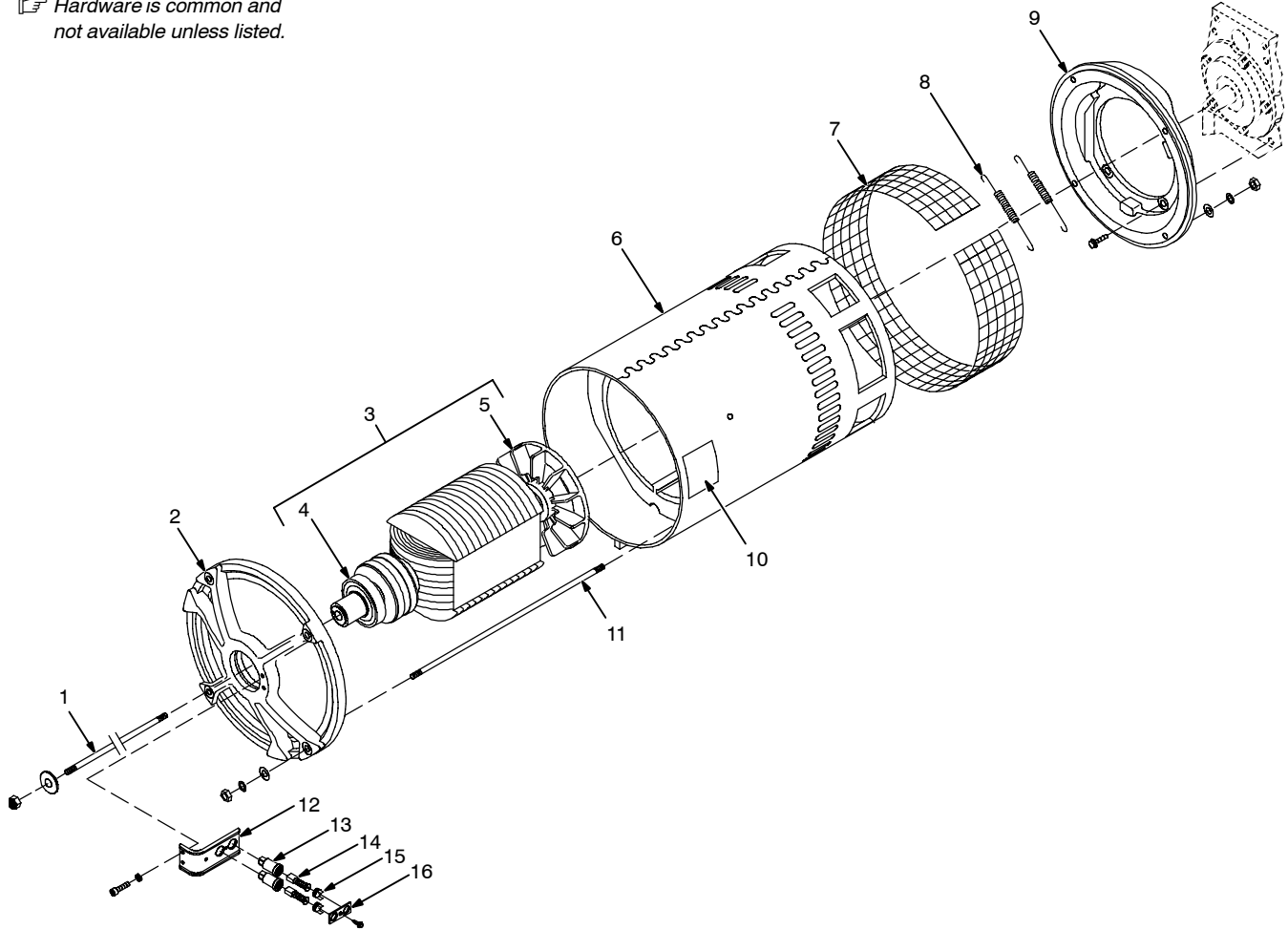

Item No.	Part No.	Description	Quantity
... 1	166 770	.. STUD, stl .375-16 x 19.750	1
... 2	160 943	.. ENDBELL	1
... 3	166 727	.. ROTOR, generator (consisting of)	1
... 4	053 390	.. BEARING, ball sgl row	1
... 5	160 566	.. FAN, rotor gen	1
... 6	+166 378	.. STATOR, generator	1
... 7	172 656	.. GUARD, generator wire mesh	1
... 8	172 674	.. SPRING, ext	2
... 9	165 850	.. ADAPTER, engine	1
... 10	176 106	.. LABEL, warning moving parts	2
... 11	170 861	.. STUD, stl .375-16 x 17.375	4
... 12	125 548	.. HOLDER, brush elect	1
... 13	005 614	.. HOLDER, brush	2
... 14	*126 984	.. BRUSH w/SPRING	2
... 15	161 306	.. CAP, brushholder	2
... 16	047 879	.. BAR, retaining brushholder	1

*Recommended Spare Parts.

To maintain the factory original performance of your equipment, use only Manufacturer's Suggested Replacement Parts. Model and serial number required when ordering parts from your local distributor.

11.4 Control Box w/Components (Fig 11.1 Item 86)

ST-801 288

 Hardware is common and not available unless listed.

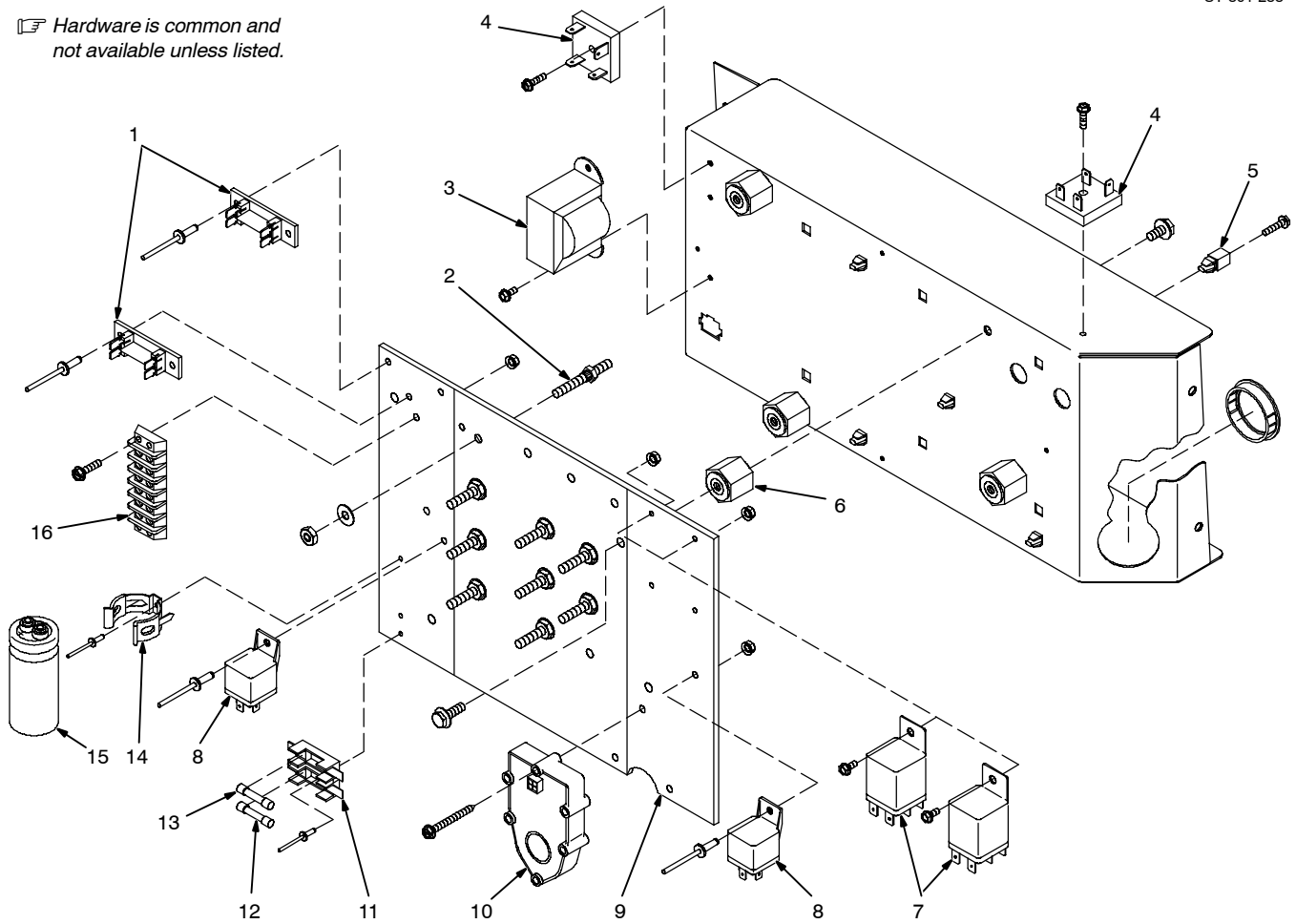

Item No.	Dia. Mkgs.	Part No.	Description	Quantity
1	D1,5	135 184	DIODE BOARD	2
2		038 889	STUD, pri board brs .250-20 x 1.750	9
		010 915	WASHER, flat brs .257 ID x .640 OD	9
		602 208	WASHER, tooth	9
		601 836	NUT, brs .250-20	9
3	T1	156 583	TRANSFORMER, control 42/36V	1
4	SR2,3	035 704	RECTIFIER, integ 40A 800V	2
5		083 147	GROMMET, scr No. 8/10 panel hole	5
6		026 947	STAND-OFF, insul .250-20 x 1.000 lg	4
7	CR5,6	174 596	RELAY, encl 110VDC DPST	2
8	CR1,4	173 069	RELAY, encl 12VDC SPDT	2
9		171 345	TERMINAL BOARD, stator hook-up (consisting of)	1
		172 449	BUS BAR	1
10		166 719	MODULE, idle	1
11		098 376	HOLDER, fuse mintr	1
12	F2	*073 426	FUSE, mintr gl slo-blo 5A 125V	1
13	F3	*142 751	FUSE, mintr cer slo-blo 30A 125V	1
14		087 111	CLAMP, capacitor	1
15	C1	087 110	CAPACITOR, elctlt 240uf 200VDC	1
16	1T	038 772	BLOCK, term 20A 6P (consisting of)	1
		601 219	LINK, jumper 20A	2

*Recommended Spare Parts.

To maintain the factory original performance of your equipment, use only Manufacturer's Suggested Replacement Parts. Model and serial number required when ordering parts from your local distributor.

12. Options and Accessories

12.1 Metro 250D

WELD METERS – DC AMP & VOLT (#042 947 Field)

Machine is prewired for easy installation of field kit.

STARTING AID KITS (#043 139 Field)

Improve starting in cold weather by adding air intake manifold glow plug. Machine is prewired.

SPARK ARRESTOR (#042 915)

May be mandatory in some areas.

METRO RUNNING GEAR (#042 941)

Easy-to-install running gear bolts onto Metro base. Not for highway use. Includes axle, wheels, fenders and tow bar.

LOCK UP KIT – FRONT PANEL (#042 921)

Secures the front panel controls of the Metro with a hinged metal panel. Includes key lock for engine access cover.

CC-5 CANVAS COVER (#040 144)

Heavy duty, blue, waterproof and mildew resistant.

RHC-14 REMOTE HAND CONTROL (#129 340)

Miniature hand control for remote current and contactor control. Includes 20 ft. (6 m) cord and 14-pin plug.

RFC-14 REMOTE FOOT CONTROL (#129 339)

Heavy duty foot current and contactor control. Includes 20 ft. (6 m) cord and 14-pin plug.

VOLTAGE-SENSING WIRE FEEDER SUPER S-32P COMPACT, PORTABLE WIRE FEEDER

Literature Index No. M/6.26

For 0.23–5/64 in. (0.6–2.0 mm) hard and flux cored wire.

HF-251 SERIES

High Frequency Arc Starter and Stabilizer
(#042 388) HF-251D-1 115 Volt
(#042 387) HF-251-2 230 Volt

A portable 250 Amp unit for 50, 60, and 100 Hz input.

3000-4AH FOUR-WHEEL TANDEM TRAILER (#042 599)

The tandem axle design enables this trailer to ride smoothly over rough terrain. The unit is equipped with fenders, lights, a leveling jack, and safety chains. The two-wheel, self-actuating hydraulic brake system operates automatically as pressure is put against the tongue of the trailer. Break-away device automatically locks the brakes if the trailer becomes loose. A hand-operated parking brake is standard.

Note: Order hitch separately.

TOOL BOX (#040 638)

For use with four-wheel trailers. Keeps tools handy. Sturdy steel construction with hinged cover. 5 in. (130 mm) divider in center of box. Attachment hardware included. Height 11 in. (280 mm), depth 10 in. (254 mm), length 44 in. (1120 mm).

EDT 2400-2B TWO-WHEEL TRAILER (#042 895)

A 1089 kg (2400 lb.) capacity trailer has a welded structural steel frame, heavy-duty axle with roller bearing hubs and leaf spring suspension. Mounting holes for all large Miller engine driven welding generators are pre-punched. Mounting hardware provided. Also included is a jack stand for raising and lowering the tongue, safety chains, and universal tongue mounting for optional hitches. An optional fender and light kit is required when trailer is used on the highway.

Note: Order hitch separately.

The EDT 2400-2B trailer and the No. 3000-4AH trailer, when equipped with fender and light kit and 50 mm (2 in.) ball hitch, conform to all applicable U.S. Federal Motor Vehicle Safety Standards in effect on date of manufacture.

FENDER AND LIGHT KIT FOR EDT 2400-2B TRAILER (#042 896)

Includes fenders, 12 Volt lights, and mounting hardware.

NO. 84X FOUR-WHEEL TANDEM TRAILER (#042 150)

For off-the-road use only. The tandem axle torsion bar design enables this trailer to ride smoothly over rough terrain.

Note: Order hitch separately. When ordering off-road trailers, the purchase order must include the statement, "For off-the-road use only."

FENDER AND LIGHT KIT FOR NO. 84X TRAILER (#042 198)

Includes fenders and 12 Volt light set.

HITCHES

CLEVIS (#042 151)

For use on No. 84X trailer. Shipping weight 5 kg (11 lbs.)

CLEVIS (#042 707)

(Not for highway use) For use with EDT 2400-2B trailer. Shipping weight 11 lbs. (5 kg)

50 mm (2 in.) BALL (#042 153)

For use with No. 84X and 3000-4AH trailers. Shipping weight 5 lbs. (2 kg)

50 mm (2 in.) BALL (#042 705)

For use with EDT 2400-2B trailer. Shipping weight 5 lbs. (2 kg)

76 mm (3 in.) LUNETTE EYE (#042 152)

For use with No. 84X and 3000-4AH trailers. Shipping weight 9 lbs. (4 kg)

64 mm (2-1/2 in.) LUNETTE EYE (#042 706)

For use with EDT 2400-2B trailer. Shipping weight 9 lbs. (4 kg)

TRUE BLUE® WARRANTY

Effective January 1, 2000

(Equipment with a serial number preface of "LA" or newer)

This limited warranty supersedes all previous Miller warranties and is exclusive with no other guarantees or warranties expressed or implied.

Warranty Questions?

Call
1-800-4-A-MILLER
for your local
Miller distributor.

Your distributor also gives
you ...

Service

You always get the fast,
reliable response you
need. Most replacement
parts can be in your
hands in 24 hours.

Support

Need fast answers to the
tough welding questions?
Contact your distributor.
The expertise of the
distributor and Miller is
there to help you, every
step of the way.

LIMITED WARRANTY – Subject to the terms and conditions below, Miller Electric Mfg. Co., Appleton, Wisconsin, warrants to its original retail purchaser that new Miller equipment sold after the effective date of this limited warranty is free of defects in material and workmanship at the time it is shipped by Miller. THIS WARRANTY IS EXPRESSLY IN LIEU OF ALL OTHER WARRANTIES, EXPRESS OR IMPLIED, INCLUDING THE WARRANTIES OF MERCHANTABILITY AND FITNESS.

Within the warranty periods listed below, Miller will repair or replace any warranted parts or components that fail due to such defects in material or workmanship. Miller must be notified in writing within thirty (30) days of such defect or failure, at which time Miller will provide instructions on the warranty claim procedures to be followed.

Miller shall honor warranty claims on warranted equipment listed below in the event of such a failure within the warranty time periods. All warranty time periods start on the date that the equipment was delivered to the original retail purchaser, or one year after the equipment is sent to a North American distributor or eighteen months after the equipment is sent to an International distributor.

1. 5 Years Parts – 3 Years Labor
 - * Original main power rectifiers
 - * Inverters (input and output rectifiers only)
2. 3 Years — Parts and Labor
 - * Transformer/Rectifier Power Sources
 - * Plasma Arc Cutting Power Sources
 - * Semi-Automatic and Automatic Wire Feeders
 - * Inverter Power Supplies
 - * Intelligit
 - * Engine Driven Welding Generators
(NOTE: Engines are warranted separately by the engine manufacturer.)
3. 1 Year — Parts and Labor
 - * DS-2 Wire Feeder
 - * Motor Driven Guns (w/exception of Spoolmate 185 & Spoolmate 250)
 - * Process Controllers
 - * Positioners and Controllers
 - * Automatic Motion Devices
 - * RFCS Foot Controls
 - * Induction Heating Power Sources
 - * Water Coolant Systems
 - * HF Units
 - * Grids
 - * Maxstar 140
 - * Spot Welders
 - * Load Banks
 - * Miller Cyclomatic Equipment
 - * Running Gear/Trailers
 - * Plasma Cutting Torches (except APT & SAF Models)
 - * Field Options
(NOTE: Field options are covered under True Blue® for the remaining warranty period of the product they are installed in, or for a minimum of one year — whichever is greater.)
4. 6 Months — Batteries
5. 90 Days — Parts
 - * MIG Guns/TIG Torches
 - * Induction Heating Coils and Blankets

- * APT, ZIPCUT & PLAZCUT Model Plasma Cutting Torches
- * Remote Controls
- * Accessory Kits
- * Replacement Parts (No labor)
- * Spoolmate 185 & Spoolmate 250
- * Canvas Covers

Miller's True Blue® Limited Warranty shall not apply to:

1. **Consumable components; such as contact tips, cutting nozzles, contactors, brushes, slip rings, relays or parts that fail due to normal wear.**
2. Items furnished by Miller, but manufactured by others, such as engines or trade accessories. These items are covered by the manufacturer's warranty, if any.
3. Equipment that has been modified by any party other than Miller, or equipment that has been improperly installed, improperly operated or misused based upon industry standards, or equipment which has not had reasonable and necessary maintenance, or equipment which has been used for operation outside of the specifications for the equipment.

MILLER PRODUCTS ARE INTENDED FOR PURCHASE AND USE BY COMMERCIAL/INDUSTRIAL USERS AND PERSONS TRAINED AND EXPERIENCED IN THE USE AND MAINTENANCE OF WELDING EQUIPMENT.

In the event of a warranty claim covered by this warranty, the exclusive remedies shall be, at Miller's option: (1) repair; or (2) replacement; or, where authorized in writing by Miller in appropriate cases, (3) the reasonable cost of repair or replacement at an authorized Miller service station; or (4) payment of or credit for the purchase price (less reasonable depreciation based upon actual use) upon return of the goods at customer's risk and expense. Miller's option of repair or replacement will be F.O.B., Factory at Appleton, Wisconsin, or F.O.B. at a Miller authorized service facility as determined by Miller. Therefore no compensation or reimbursement for transportation costs of any kind will be allowed.

TO THE EXTENT PERMITTED BY LAW, THE REMEDIES PROVIDED HEREIN ARE THE SOLE AND EXCLUSIVE REMEDIES. IN NO EVENT SHALL MILLER BE LIABLE FOR DIRECT, INDIRECT, SPECIAL, INCIDENTAL OR CONSEQUENTIAL DAMAGES (INCLUDING LOSS OF PROFIT), WHETHER BASED ON CONTRACT, TORT OR ANY OTHER LEGAL THEORY.

ANY EXPRESS WARRANTY NOT PROVIDED HEREIN AND ANY IMPLIED WARRANTY, GUARANTY OR REPRESENTATION AS TO PERFORMANCE, AND ANY REMEDY FOR BREACH OF CONTRACT TORT OR ANY OTHER LEGAL THEORY WHICH, BUT FOR THIS PROVISION, MIGHT ARISE BY IMPLICATION, OPERATION OF LAW, CUSTOM OF TRADE OR COURSE OF DEALING, INCLUDING ANY IMPLIED WARRANTY OF MERCHANTABILITY OR FITNESS FOR PARTICULAR PURPOSE, WITH RESPECT TO ANY AND ALL EQUIPMENT FURNISHED BY MILLER IS EXCLUDED AND DISCLAIMED BY MILLER.

Some states in the U.S.A. do not allow limitations of how long an implied warranty lasts, or the exclusion of incidental, indirect, special or consequential damages, so the above limitation or exclusion may not apply to you. This warranty provides specific legal rights, and other rights may be available, but may vary from state to state.

In Canada, legislation in some provinces provides for certain additional warranties or remedies other than as stated herein, and to the extent that they may not be waived, the limitations and exclusions set out above may not apply. This Limited Warranty provides specific legal rights, and other rights may be available, but may vary from province to province.





Owner's Record

Please complete and retain with your personal records.

Model Name	Serial/Style Number
Purchase Date	(Date which equipment was delivered to original customer.)
Distributor	
Address	
City	
State	Zip



For Service

Call 1-800-4-A-Miller or see our website at www.MillerWelds.com to locate a DISTRIBUTOR or SERVICE AGENCY near you.

Always provide Model Name and Serial/Style Number.

Contact your Distributor for:	Welding Supplies and Consumables
	Options and Accessories
	Personal Safety Equipment
	Service and Repair
	Replacement Parts
	Training (Schools, Videos, Books)
	Technical Manuals (Servicing Information and Parts)
	Circuit Diagrams
	Welding Process Handbooks

Contact the Delivering Carrier for: File a claim for loss or damage during shipment.

For assistance in filing or settling claims, contact your distributor and/or equipment manufacturer's Transportation Department.

Miller Electric Mfg. Co.

An Illinois Tool Works Company
1635 West Spencer Street
Appleton, WI 54914 USA

International Headquarters—USA

USA Phone: 920-735-4505 Auto-Attended
USA & Canada FAX: 920-735-4134
International FAX: 920-735-4125

European Headquarters – United Kingdom

Phone: 44 (0) 1204-593493
FAX: 44 (0) 1204-598066

www.MillerWelds.com

