



OM-494

191 862Q

September 2005

**Processes**



Stick (SMAW) Welding



MIG (GMAW) Welding



Flux Cored (FCAW) Welding



TIG (GTAW) Welding



Air Carbon Arc (CAC-A)  
Cutting and Gouging

**Description**



Dual-Operator Engine Driven Welding  
Generator

# Miller DU-OP™

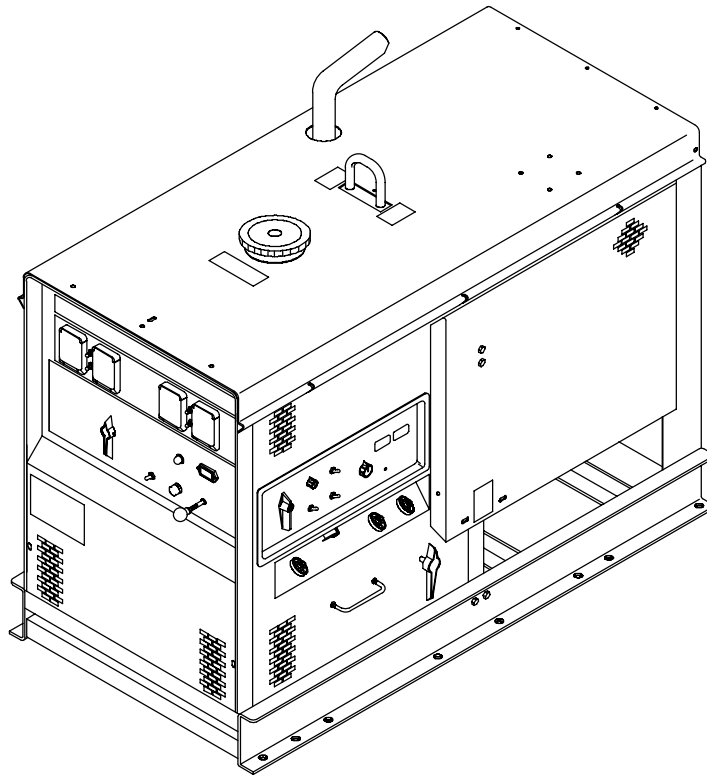

## OWNER'S MANUAL



Visit our website at  
[www.MillerWelds.com](http://www.MillerWelds.com)

File: Engine Drive



# From Miller to You

---

*Thank you and congratulations* on choosing Miller. Now you can get the job done and get it done right. We know you don't have time to do it any other way.

That's why when Niels Miller first started building arc welders in 1929, he made sure his products offered long-lasting value and superior quality. Like you, his customers couldn't afford anything less. Miller products had to be more than the best they could be. They had to be the best you could buy.

Today, the people that build and sell Miller products continue the tradition. They're just as committed to providing equipment and service that meets the high standards of quality and value established in 1929.

This Owner's Manual is designed to help you get the most out of your Miller products. Please take time to read the Safety precautions. They will help you protect yourself against potential hazards on the worksite.

We've made installation and operation quick and easy. With Miller you can count on years of reliable service with proper maintenance. And if for some reason the unit needs repair, there's a Troubleshooting section that will help you figure out what the problem is. The parts list will then help you to decide the exact part you may need to fix the problem. Warranty and service information for your particular model are also provided.



Miller is the first welding equipment manufacturer in the U.S.A. to be registered to the ISO 9001:2000 Quality System Standard.

Miller Electric manufactures a full line of welders and welding related equipment. For information on other quality Miller products, contact your local Miller distributor to receive the latest full line catalog or individual specification sheets. **To locate your nearest distributor or service agency call 1-800-4-A-Miller, or visit us at [www.MillerWelds.com](http://www.MillerWelds.com) on the web.**



Working as hard as you do – every power source from Miller is backed by the most hassle-free warranty in the business.



# TABLE OF CONTENTS

<b>SECTION 1 – SAFETY PRECAUTIONS – READ BEFORE USING</b> .....	<b>1</b>
1-1. Symbol Usage .....	1
1-2. Arc Welding Hazards .....	1
1-3. Engine Hazards .....	2
1-4. Compressed Air Hazards .....	3
1-5. Additional Symbols For Installation, Operation, And Maintenance .....	3
1-6. California Proposition 65 Warnings .....	4
1-7. Principal Safety Standards .....	4
1-8. EMF Information .....	4
<b>SECTION 2 – CONSIGNES DE SÉCURITÉ – LIRE AVANT UTILISATION</b> .....	<b>5</b>
2-1. Signification des symboles .....	5
2-2. Dangers relatifs au soudage à l'arc .....	5
2-3. Dangers existant en relation avec le moteur .....	6
2-4. Dangers liés à l'air comprimé .....	7
2-5. Dangers supplémentaires en relation avec l'installation, le fonctionnement et la maintenance .....	7
2-6. Proposition californienne 65 Avertissements .....	8
2-7. Principales normes de sécurité .....	8
2-8. Information EMF .....	8
<b>SECTION 3 – DEFINITIONS</b> .....	<b>9</b>
3-1. Symbols And Definitions .....	9
<b>SECTION 4 – SPECIFICATIONS</b> .....	<b>10</b>
4-1. Description .....	10
4-2. Weld, Power, And Engine Specifications .....	10
4-3. Dimensions, Weights, And Operating Angles .....	10
4-4. Fuel Consumption .....	11
4-5. AC Generator Power .....	11
4-6. Duty Cycle And Overheating .....	12
4-7. Volt-Ampere Curves .....	13
<b>SECTION 5 – INSTALLATION</b> .....	<b>14</b>
5-1. Installing Welding Generator .....	14
5-2. Activating The Dry Charge Battery (If Applicable) .....	15
5-3. Connecting The Battery .....	15
5-4. Installing Exhaust Pipe .....	16
5-5. Engine Prestart Checks .....	16
5-6. Safety Information For Connecting To Weld Output Terminals .....	17
5-7. Weld Output Terminals .....	17
5-8. Making Dual Operator CC Weld Connections w/ Separate Work Cables .....	18
5-9. Making Dual Operator Mode CC Weld Connections w/ Common Work Cable .....	19
5-10. Making Dual Operator CV Weld Connections w/ Separate Work Cables .....	20
5-11. Making Dual Operator CV Weld Connections w/ Common Work Cable .....	21
5-12. Making Dual Operator CC And CV Weld Connections w/ Separate Work Cables .....	22
5-13. Making Dual Operator CC And CV Weld Connections w/ Common Work Cable .....	23
5-14. Making Single Operator CC Weld Connections .....	24
5-15. Selecting Weld Cable Sizes* .....	26
5-16. Installing Ether Cylinder (Optional Ether Starting Aid) .....	27
5-17. Remote 14 Receptacle Information .....	27
5-18. Remote 14 Receptacle Connections .....	28
<b>SECTION 6 – OPERATING THE WELDING GENERATOR</b> .....	<b>29</b>
6-1. Engine Controls .....	29
6-2. Weld Controls (See Section 6-3) .....	30
6-3. Weld Control Descriptions (See Section 6-2) .....	31

# TABLE OF CONTENTS

---

<b>SECTION 7 – OPERATING AUXILIARY EQUIPMENT</b> .....	<b>32</b>
7-1. 120 Volt And 240 Volt Duplex Receptacles .....	32
<b>SECTION 8 – MAINTENANCE &amp; TROUBLESHOOTING</b> .....	<b>33</b>
8-1. Routine Maintenance .....	33
8-2. Maintenance Label .....	34
8-3. Servicing Air Cleaner .....	35
8-4. Servicing Fuel And Lubrication Systems .....	36
8-5. Adjusting Engine Speed .....	37
8-6. Servicing Optional Ether Starting Aid .....	37
8-7. Checking And Replacing Alternator Belt .....	38
8-8. Resetting Fan Belt Safety Shutdown .....	39
8-9. Inspecting And Cleaning Optional Spark Arrestor Muffler .....	40
8-10. Checking Generator Brushes .....	40
8-11. Circuit Protection .....	41
8-12. Troubleshooting .....	42
<b>SECTION 9 – ELECTRICAL DIAGRAMS</b> .....	<b>46</b>
<b>SECTION 10 – RUN-IN PROCEDURE</b> .....	<b>48</b>
10-1. Wetstacking .....	48
10-2. Run-In Procedure Using Load Bank .....	49
10-3. Run-In Procedure Using Resistance Grid .....	50
<b>SECTION 11 – GENERATOR POWER GUIDELINES</b> .....	<b>51</b>
<b>SECTION 12 – PARTS LIST</b> .....	<b>58</b>

# SECTION 1 – SAFETY PRECAUTIONS – READ BEFORE USING

rom\_nd\_3/05

▲ **Warning: Protect yourself and others from injury — read and follow these precautions.**

## 1-1. Symbol Usage



Means Warning! Watch Out! There are possible hazards with this procedure! The possible hazards are shown in the adjoining symbols.

▲ **Marks a special safety message.**

☞ Means “Note”; not safety related.



This group of symbols means Warning! Watch Out! possible ELECTRIC SHOCK, MOVING PARTS, and HOT PARTS hazards. Consult symbols and related instructions below for necessary actions to avoid the hazards.

## 1-2. Arc Welding Hazards

▲ **The symbols shown below are used throughout this manual to call attention to and identify possible hazards. When you see the symbol, watch out, and follow the related instructions to avoid the hazard. The safety information given below is only a summary of the more complete safety information found in the Safety Standards listed in Section 1-7. Read and follow all Safety Standards.**

▲ **Only qualified persons should install, operate, maintain, and repair this unit.**

▲ **During operation, keep everybody, especially children, away.**



### ELECTRIC SHOCK can kill.

Touching live electrical parts can cause fatal shocks or severe burns. The electrode and work circuit is electrically live whenever the output is on. The input power circuit and machine internal circuits are also live when power is on. In semiautomatic or automatic wire welding, the wire, wire reel, drive roll housing, and all metal parts touching the welding wire are electrically live. Incorrectly installed or improperly grounded equipment is a hazard.

- Do not touch live electrical parts.
- Wear dry, hole-free insulating gloves and body protection.
- Insulate yourself from work and ground using dry insulating mats or covers big enough to prevent any physical contact with the work or ground.
- Do not use AC output in damp areas, if movement is confined, or if there is a danger of falling.
- Use AC output ONLY if required for the welding process.
- If AC output is required, use remote output control if present on unit.
- Additional safety precautions are required when any of the following electrically hazardous conditions are present: in damp locations or while wearing wet clothing; on metal structures such as floors, gratings, or scaffolds; when in cramped positions such as sitting, kneeling, or lying; or when there is a high risk of unavoidable or accidental contact with the workpiece or ground. For these conditions, use the following equipment in order presented: 1) a semiautomatic DC constant voltage (wire) welder, 2) a DC manual (stick) welder, or 3) an AC welder with reduced open-circuit voltage. In most situations, use of a DC, constant voltage wire welder is recommended. And, do not work alone!
- Disconnect input power or stop engine before installing or servicing this equipment. Lockout/tagout input power according to OSHA 29 CFR 1910.147 (see Safety Standards).
- Properly install and ground this equipment according to its Owner's Manual and national, state, and local codes.
- Always verify the supply ground — check and be sure that input power cord ground wire is properly connected to ground terminal in disconnect box or that cord plug is connected to a properly grounded receptacle outlet.
- When making input connections, attach proper grounding conductor first — double-check connections.
- Frequently inspect input power cord for damage or bare wiring — replace cord immediately if damaged — bare wiring can kill.
- Turn off all equipment when not in use.
- Do not use worn, damaged, undersized, or poorly spliced cables.
- Do not drape cables over your body.
- If earth grounding of the workpiece is required, ground it directly with a separate cable.
- Do not touch electrode if you are in contact with the work, ground, or another electrode from a different machine.
- Use only well-maintained equipment. Repair or replace damaged parts at once. Maintain unit according to manual.

- Do not touch electrode holders connected to two welding machines at the same time since double open-circuit voltage will be present.
- Wear a safety harness if working above floor level.
- Keep all panels and covers securely in place.
- Clamp work cable with good metal-to-metal contact to workpiece or worktable as near the weld as practical.
- Insulate work clamp when not connected to workpiece to prevent contact with any metal object.
- Do not connect more than one electrode or work cable to any single weld output terminal.

### SIGNIFICANT DC VOLTAGE exists in inverters after stopping engine.

- Stop engine on inverter and discharge input capacitors according to instructions in Maintenance Section before touching any parts.

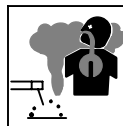

### FUMES AND GASES can be hazardous.

Welding produces fumes and gases. Breathing these fumes and gases can be hazardous to your health.

- Keep your head out of the fumes. Do not breathe the fumes.
- If inside, ventilate the area and/or use local forced ventilation at the arc to remove welding fumes and gases.
- If ventilation is poor, wear an approved air-supplied respirator.
- Read and understand the Material Safety Data Sheets (MSDSs) and the manufacturer's instructions for metals, consumables, coatings, cleaners, and degreasers.
- Work in a confined space only if it is well ventilated, or while wearing an air-supplied respirator. Always have a trained watchperson nearby. Welding fumes and gases can displace air and lower the oxygen level causing injury or death. Be sure the breathing air is safe.
- Do not weld in locations near degreasing, cleaning, or spraying operations. The heat and rays of the arc can react with vapors to form highly toxic and irritating gases.
- Do not weld on coated metals, such as galvanized, lead, or cadmium plated steel, unless the coating is removed from the weld area, the area is well ventilated, and while wearing an air-supplied respirator. The coatings and any metals containing these elements can give off toxic fumes if welded.



### BUILDUP OF GAS can injure or kill.

- Shut off shielding gas supply when not in use.
- Always ventilate confined spaces or use approved air-supplied respirator.

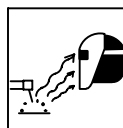

### ARC RAYS can burn eyes and skin.

Arc rays from the welding process produce intense visible and invisible (ultraviolet and infrared) rays that can burn eyes and skin. Sparks fly off from the weld.

- Wear an approved welding helmet fitted with a proper shade of filter lenses to protect your face and eyes from arc rays and sparks when welding or watching (see ANSI Z49.1 and Z87.1 listed in Safety Standards).
- Wear approved safety glasses with side shields under your helmet.
- Use protective screens or barriers to protect others from flash, glare, and sparks; warn others not to watch the arc.
- Wear protective clothing made from durable, flame-resistant material (leather, heavy cotton, or wool) and foot protection.



### WELDING can cause fire or explosion.

Welding on closed containers, such as tanks, drums, or pipes, can cause them to blow up. Sparks can fly off from the welding arc. The flying sparks, hot workpiece, and hot equipment can cause fires and burns. Accidental contact of electrode to metal objects can cause sparks, explosion, overheating, or fire. Check and be sure the area is safe before doing any welding.

- Remove all flammables within 35 ft (10.7 m) of the welding arc. If this is not possible, tightly cover them with approved covers.
- Do not weld where flying sparks can strike flammable material.
- Protect yourself and others from flying sparks and hot metal.
- Be alert that welding sparks and hot materials from welding can easily go through small cracks and openings to adjacent areas.
- Watch for fire, and keep a fire extinguisher nearby.
- Be aware that welding on a ceiling, floor, bulkhead, or partition can cause fire on the hidden side.
- Do not weld on closed containers such as tanks, drums, or pipes, unless they are properly prepared according to AWS F4.1 (see Safety Standards).
- Connect work cable to the work as close to the welding area as practical to prevent welding current from traveling long, possibly unknown paths and causing electric shock, sparks, and fire hazards.
- Do not use welder to thaw frozen pipes.
- Remove stick electrode from holder or cut off welding wire at contact tip when not in use.
- Wear oil-free protective garments such as leather gloves, heavy shirt, cuffless trousers, high shoes, and a cap.
- Remove any combustibles, such as a butane lighter or matches, from your person before doing any welding.
- Follow requirements in OSHA 1910.252 (a) (2) (iv) and NFPA 51B for hot work and have a fire watcher and extinguisher nearby.

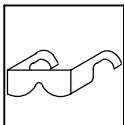

### FLYING METAL can injure eyes.

- Welding, chipping, wire brushing, and grinding cause sparks and flying metal. As welds cool, they can throw off slag.
- Wear approved safety glasses with side shields even under your welding helmet.

## 1-3. Engine Hazards



### BATTERY EXPLOSION can BLIND.

- Always wear a face shield, rubber gloves, and protective clothing when working on a battery.
- Stop engine before disconnecting or connecting battery cables or servicing battery.
- Do not allow tools to cause sparks when working on a battery.
- Do not use welder to charge batteries or jump start vehicles.
- Observe correct polarity (+ and -) on batteries.
- Disconnect negative (-) cable first and connect it last.



### FUEL can cause fire or explosion.

- Stop engine and let it cool off before checking or adding fuel.
- Do not add fuel while smoking or if unit is near any sparks or open flames.
- Do not overfill tank — allow room for fuel to expand.
- Do not spill fuel. If fuel is spilled, clean up before starting engine.
- Dispose of rags in a fireproof container.
- Always keep nozzle in contact with tank when fueling.



### HOT PARTS can cause severe burns.

- Do not touch hot parts bare handed.
- Allow cooling period before working on equipment.
- To handle hot parts, use proper tools and/or wear heavy, insulated welding gloves and clothing to prevent burns.



### NOISE can damage hearing.

Noise from some processes or equipment can damage hearing.

- Wear approved ear protection if noise level is high.



### MAGNETIC FIELDS can affect pacemakers.

- Pacemaker wearers keep away.
- Wearers should consult their doctor before going near arc welding, gouging, or spot welding operations.

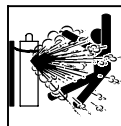

### CYLINDERS can explode if damaged.

Shielding gas cylinders contain gas under high pressure. If damaged, a cylinder can explode. Since gas cylinders are normally part of the welding process, be sure to treat them carefully.

- Protect compressed gas cylinders from excessive heat, mechanical shocks, physical damage, slag, open flames, sparks, and arcs.
- Install cylinders in an upright position by securing to a stationary support or cylinder rack to prevent falling or tipping.
- Keep cylinders away from any welding or other electrical circuits.
- Never drape a welding torch over a gas cylinder.
- Never allow a welding electrode to touch any cylinder.
- Never weld on a pressurized cylinder — explosion will result.
- Use only correct shielding gas cylinders, regulators, hoses, and fittings designed for the specific application; maintain them and associated parts in good condition.
- Turn face away from valve outlet when opening cylinder valve.
- Keep protective cap in place over valve except when cylinder is in use or connected for use.
- Use the right equipment, correct procedures, and sufficient number of persons to lift and move cylinders.
- Read and follow instructions on compressed gas cylinders, associated equipment, and Compressed Gas Association (CGA) publication P-1 listed in Safety Standards.



### MOVING PARTS can cause injury.

- Keep away from fans, belts, and rotors.
- Keep all doors, panels, covers, and guards closed and securely in place.
- Stop engine before installing or connecting unit.
- Have only qualified people remove doors, panels, covers, or guards for maintenance and troubleshooting as necessary.
- To prevent accidental starting during servicing, disconnect negative (-) battery cable from battery.
- Keep hands, hair, loose clothing, and tools away from moving parts.
- Reinstall doors, panels, covers, or guards when servicing is finished and before starting engine.
- Before working on generator, remove spark plugs or injectors to keep engine from kicking back or starting.
- Block flywheel so that it will not turn while working on generator components.



### HOT PARTS can cause severe burns.

- Do not touch hot engine parts.
- Allow cooling period before maintaining.
- Wear protective gloves and clothing when working on a hot engine.



### STEAM AND HOT COOLANT can burn.

- If possible, check coolant level when engine is cold to avoid scalding.
- Always check coolant level at overflow tank, if present on unit, instead of radiator (unless told otherwise in maintenance section or engine manual).
- If the engine is warm, checking is needed, and there is no overflow tank, follow the next two statements.
- Wear safety glasses and gloves and put a rag over radiator cap.
- Turn cap slightly and let pressure escape slowly before completely removing cap.



### ENGINE EXHAUST GASES can kill.

- Use equipment outside in open, well-ventilated areas.
- If used in a closed area, vent engine exhaust outside and away from any building air intakes.

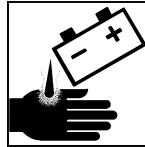

### BATTERY ACID can BURN SKIN and EYES.

- Do not tip battery.
- Replace damaged battery.
- Flush eyes and skin immediately with water.

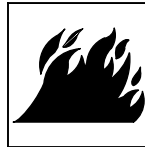

### ENGINE HEAT can cause fire.

- Do not locate unit on, over, or near combustible surfaces or flammables.
- Keep exhaust and exhaust pipes way from flammables.



### EXHAUST SPARKS can cause fire.

- Do not let engine exhaust sparks cause fire.
- Use approved engine exhaust spark arrester in required areas — see applicable codes.

## 1-4. Compressed Air Hazards



### BREATHING COMPRESSED AIR can cause serious injury or death.

- Do not use compressed air for breathing.
- Use only for cutting, gouging, and tools.

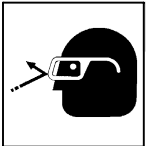

### COMPRESSED AIR can cause injury.

- Wear approved safety goggles.
- Do not direct air stream toward self or others.



### TRAPPED AIR PRESSURE AND WHIPPING HOSES can cause injury.

- Release air pressure from tools and system before servicing, adding or changing attachments, or opening compressor oil drain or oil fill cap.



### HOT METAL from air arc cutting and gouging can cause fire or explosion.

- Do not cut or gouge near flammables.
- Watch for fire; keep extinguisher nearby.



### HOT PARTS can cause burns and injury.

- Do not touch hot compressor or air system parts.
- Let system cool down before touching or servicing.

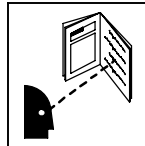

### READ INSTRUCTIONS.

- Read Owner's Manual before using or servicing unit.
- Stop engine and release air pressure before servicing.
- Use only genuine Miller/Hobart replacement parts.

## 1-5. Additional Symbols For Installation, Operation, And Maintenance



### FALLING UNIT can cause injury.

- Use lifting eye to lift unit and properly installed accessories only. Do not exceed maximum lift eye weight rating (see Specifications).
- Lift and support unit only with proper equipment and correct procedures.
- If using lift forks to move unit, be sure forks are long enough to extend beyond opposite side of unit.

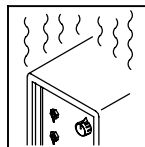

### OVERUSE can cause OVERHEATING.

- Allow cooling period; follow rated duty cycle.
- Reduce current or reduce duty cycle before starting to weld again.
- Do not block or filter airflow to unit.

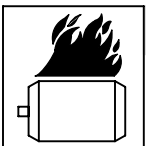

### OVERHEATING can damage motors.

- Turn off or unplug equipment before starting or stopping engine.
- Do not let low voltage and frequency caused by low engine speed damage electric motors.
- Do not connect 50 or 60 Hertz motors to the 100 Hertz receptacle where applicable.

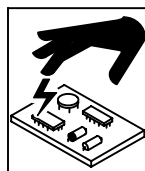

### STATIC (ESD) can damage PC boards.

- Put on grounded wrist strap BEFORE handling boards or parts.
- Use proper static-proof bags and boxes to store, move, or ship PC boards.

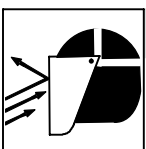

### FLYING SPARKS can cause injury.

- Wear a face shield to protect eyes and face.
- Shape tungsten electrode only on grinder with proper guards in a safe location wearing proper face, hand, and body protection.
- Sparks can cause fires — keep flammables away.



### TILTING OF TRAILER can cause injury.

- Use tongue jack or blocks to support weight.
- Properly install welding generator onto trailer according to instructions supplied with trailer.

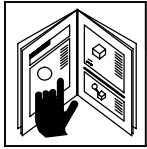

## READ INSTRUCTIONS.

- Use only genuine MILLER/Hobart replacement parts.
- Perform engine and air compressor (if applicable) maintenance and service according to this manual and the engine/air compressor (if applicable) manuals.

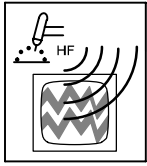

## H.F. RADIATION can cause interference.

- High-frequency (H.F.) can interfere with radio navigation, safety services, computers, and communications equipment.
- Have only qualified persons familiar with electronic equipment perform this installation.
- The user is responsible for having a qualified electrician promptly correct any interference problem resulting from the installation.
- If notified by the FCC about interference, stop using the equipment at once.
- Have the installation regularly checked and maintained.
- Keep high-frequency source doors and panels tightly shut, keep spark gaps at correct setting, and use grounding and shielding to minimize the possibility of interference.

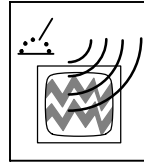

## ARC WELDING can cause interference.

- Electromagnetic energy can interfere with sensitive electronic equipment such as microprocessors, computers, and computer-driven equipment such as robots.
- Be sure all equipment in the welding area is electromagnetically compatible.
- To reduce possible interference, keep weld cables as short as possible, close together, and down low, such as on the floor.
- Locate welding operation 100 meters from any sensitive electronic equipment.
- Be sure this welding machine is installed and grounded according to this manual.
- If interference still occurs, the user must take extra measures such as moving the welding machine, using shielded cables, using line filters, or shielding the work area.

## 1-6. California Proposition 65 Warnings

- ▲ **Welding or cutting equipment produces fumes or gases which contain chemicals known to the State of California to cause birth defects and, in some cases, cancer. (California Health & Safety Code Section 25249.5 et seq.)**
- ▲ **Battery posts, terminals and related accessories contain lead and lead compounds, chemicals known to the State of California to cause cancer and birth defects or other reproductive harm. Wash hands after handling.**

### For Gasoline Engines:

- ▲ **Engine exhaust contains chemicals known to the State of California to cause cancer, birth defects, or other reproductive harm.**

### For Diesel Engines:

- ▲ **Diesel engine exhaust and some of its constituents are known to the State of California to cause cancer, birth defects, and other reproductive harm.**

## 1-7. Principal Safety Standards

*Safety in Welding, Cutting, and Allied Processes*, ANSI Standard Z49.1, from Global Engineering Documents (phone: 1-877-413-5184, website: www.global.ihs.com).

*Recommended Safe Practices for the Preparation for Welding and Cutting of Containers and Piping*, American Welding Society Standard AWS F4.1, from Global Engineering Documents (phone: 1-877-413-5184, website: www.global.ihs.com).

*National Electrical Code*, NFPA Standard 70, from National Fire Protection Association, P.O. Box 9101, 1 Battery March Park, Quincy, MA 02269-9101 (phone: 617-770-3000, website: www.nfpa.org and www.sparky.org).

*Safe Handling of Compressed Gases in Cylinders*, CGA Pamphlet P-1, from Compressed Gas Association, 1735 Jefferson Davis Highway, Suite 1004, Arlington, VA 22202-4102 (phone: 703-412-0900, website: www.cganet.com).

*Code for Safety in Welding and Cutting*, CSA Standard W117.2, from Canadian Standards Association, Standards Sales, 178 Rexdale Bou-

levard, Rexdale, Ontario, Canada M9W 1R3 (phone: 800-463-6727 or in Toronto 416-747-4044, website: www.csa-international.org).

*Practice For Occupational And Educational Eye And Face Protection*, ANSI Standard Z87.1, from American National Standards Institute, 11 West 42nd Street, New York, NY 10036-8002 (phone: 212-642-4900, website: www.ansi.org).

*Standard for Fire Prevention During Welding, Cutting, and Other Hot Work*, NFPA Standard 51B, from National Fire Protection Association, P.O. Box 9101, 1 Battery March Park, Quincy, MA 02269-9101 (phone: 617-770-3000, website: www.nfpa.org).

OSHA, Occupational Safety and Health Standards for General Industry, Title 29, Code of Federal Regulations (CFR), Part 1910, Subpart Q, and Part 1926, Subpart J, from U.S. Government Printing Office, Superintendent of Documents, P.O. Box 371954, Pittsburgh, PA 15250 (there are 10 Regional Offices—phone for Region 5, Chicago, is 312-353-2220, website: www.osha.gov).

## 1-8. EMF Information

Considerations About Welding And The Effects Of Low Frequency Electric And Magnetic Fields

Welding current, as it flows through welding cables, will cause electromagnetic fields. There has been and still is some concern about such fields. However, after examining more than 500 studies spanning 17 years of research, a special blue ribbon committee of the National Research Council concluded that: "The body of evidence, in the committee's judgment, has not demonstrated that exposure to power-frequency electric and magnetic fields is a human-health hazard." However, studies are still going forth and evidence continues to be examined. Until the final conclusions of the research are reached, you may wish to minimize your exposure to electromagnetic fields when welding or cutting.

To reduce magnetic fields in the workplace, use the following procedures:

1. Keep cables close together by twisting or taping them.
2. Arrange cables to one side and away from the operator.
3. Do not coil or drape cables around your body.
4. Keep welding power source and cables as far away from operator as practical.
5. Connect work clamp to workpiece as close to the weld as possible.

### About Pacemakers:

Pacemaker wearers consult your doctor before welding or going near welding operations. If cleared by your doctor, then following the above procedures is recommended.



# SECTION 2 – CONSIGNES DE SÉCURITÉ – LIRE AVANT UTILISATION

rom\_fre 3/05

▲ **Avertissement: Protégez vous et les autres des blessures – lisez et suivez ces précautions.**

## 2-1. Signification des symboles



Signifie Mise en garde ! Soyez vigilant ! Cette procédure présente des risques de danger ! Ceux-ci sont identifiés par des symboles adjacents aux directives.

▲ **Identifie un message de sécurité particulier.**

☞ Signifie NOTA ; n'est pas relatif à la sécurité.



Ce groupe de symboles signifie Mise en garde ! Soyez vigilant ! Il y a des risques de danger reliés aux CHOCS ÉLEC-

TRIFIQUES, aux PIÈCES EN MOUVEMENT et aux PIÈCES CHAUDES. Reportez-vous aux symboles et aux directives ci-dessous afin de connaître les mesures à prendre pour éviter tout danger.

## 2-2. Dangers relatifs au soudage à l'arc

▲ **Les symboles présentés ci-après sont utilisés tout au long du présent manuel pour attirer votre attention et identifier les risques de danger. Lorsque vous voyez un symbole, soyez vigilant et suivez les directives mentionnées afin d'éviter tout danger. Les consignes de sécurité présentées ci-après ne font que résumer l'information contenue dans les normes de sécurité énumérées à la section 2-7. Veuillez lire et respecter toutes ces normes de sécurité.**

▲ **L'installation, l'utilisation, l'entretien et les réparations ne doivent être confiés qu'à des personnes qualifiées.**

▲ **Au cours de l'utilisation, tenir toute personne à l'écart et plus particulièrement les enfants.**



### UN CHOC ÉLECTRIQUE peut tuer.

Un simple contact avec des pièces électriques peut provoquer une électrocution ou des blessures graves. L'électrode et le circuit de soudage sont sous tension dès que l'appareil est sur ON. Le circuit d'entrée et les circuits internes de l'appareil sont également sous tension à ce moment-là. En soudage semi-automatique ou automatique, le fil, le dévidoir, le logement des galets d'entraînement et les pièces métalliques en contact avec le fil de soudage sont sous tension. Des matériels mal installés ou mal mis à la terre présentent un danger.

- Ne jamais toucher les pièces électriques sous tension.
- Porter des gants et des vêtements de protection secs ne comportant pas de trous.
- S'isoler de la pièce et de la terre au moyen de tapis ou d'autres moyens isolants suffisamment grands pour empêcher le contact physique éventuel avec la pièce ou la terre.
- Ne pas se servir de source électrique à courant électrique dans les zones humides, dans les endroits confinés ou là où on risque de tomber.
- Se servir d'une source électrique à courant électrique UNIQUEMENT si le procédé de soudage le demande.
- Si l'utilisation d'une source électrique à courant électrique s'avère nécessaire, se servir de la fonction de télécommande si l'appareil en est équipé.
- Des précautions de sécurité supplémentaires sont requises dans des environnements à risque comme: les endroits humides ou lorsque l'on porte des vêtements mouillés; sur des structures métalliques au sol, grillages et échafaudages; dans des positions assises, à genoux et allongées; ou quand il y a un risque important de contact accidentel avec la pièce ou le sol. Dans ces cas utiliser les appareils suivants dans l'ordre de préférence: 1) un poste à souder DC semi-automatique de type CV (MIG/MAG), 2) un poste à souder manuel (électrode enrobée) DC, 3) un poste à souder manuel AC avec tension à vide réduite. Dans la plupart des cas, un poste courant continu de type CV est recommandé. Et, ne pas travailler seul!
- Couper l'alimentation ou arrêter le moteur avant de procéder à l'installation, à la réparation ou à l'entretien de l'appareil. Déverrouiller l'alimentation selon la norme OSHA 29 CFR 1910.147 (voir normes de sécurité).
- Installer et mettre à la terre correctement cet appareil conformément à son manuel d'utilisation et aux codes nationaux, provinciaux et municipaux.
- Toujours vérifier la terre du cordon d'alimentation – Vérifier et s'assurer que le fil de terre du cordon d'alimentation est bien raccordé à la borne de terre du sectionneur ou que la fiche du cordon est raccordée à une prise correctement mise à la terre.
- En effectuant les raccordements d'entrée fixer d'abord le conducteur de mise à la terre approprié et contre-vérifier les connexions.
- Vérifier fréquemment le cordon d'alimentation pour voir s'il n'est pas endommagé ou dénudé – remplacer le cordon immédiatement s'il est endommagé – un câble dénudé peut provoquer une électrocution.
- Mettre l'appareil hors tension quand on ne l'utilise pas.
- Ne pas utiliser des câbles usés, endommagés, de grosseur insuffisante ou mal épluchés.
- Ne pas enrouler les câbles autour du corps.
- Si la pièce soudée doit être mise à la terre, la faire directement avec un câble distinct – ne pas utiliser le connecteur de pièce ou le câble de retour.
- Ne pas toucher l'électrode quand on est en contact avec la pièce, la terre ou une électrode provenant d'une autre machine.
- Ne pas toucher des porte électrodes connectés à deux machines en même temps à cause de la présence d'une tension à vide doublée.
- N'utiliser qu'un matériel en bon état. Réparer ou remplacer sur-le-champ les pièces endommagées. Entretien de l'appareil conformément à ce manuel.

- Porter un harnais de sécurité quand on travaille en hauteur.
- Maintenir solidement en place tous les panneaux et capots.
- Fixer le câble de retour de façon à obtenir un bon contact métal-métal avec la pièce à souder ou la table de travail, le plus près possible de la soudure.
- Isoler la pince de masse quand pas mis à la pièce pour éviter le contact avec tout objet métallique.

### Une tension DC importante subsiste à l'intérieur des onduleurs après avoir coupé l'alimentation.

- Couper l'alimentation du poste et décharger les condensateurs d'entrée comme indiqué dans la Section Maintenance avant de toucher des composants.

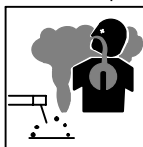

### LES FUMÉES ET LES GAZ peuvent être dangereux.

Le soudage génère des fumées et des gaz. Leur inhalation peut être dangereux pour votre santé.

- Eloigner votre tête des fumées. Ne pas respirer les fumées.
- À l'intérieur, ventiler la zone et/ou utiliser une ventilation forcée au niveau de l'arc pour l'évacuation des fumées et des gaz de soudage.
- Si la ventilation est médiocre, porter un respirateur anti-vapeurs approuvé.
- Lire et comprendre les spécifications de sécurité des matériaux (MSDS) et les instructions du fabricant concernant les métaux, les consommables, les revêtements, les nettoyeurs et les dégraisseurs.
- Travailler dans un espace fermé seulement s'il est bien ventilé ou en portant un respirateur à alimentation d'air. Demander toujours à un surveillant dûment formé de se tenir à proximité. Des fumées et des gaz de soudage peuvent déplacer l'air et abaisser le niveau d'oxygène provoquant des blessures ou des accidents mortels. S'assurer que l'air de respiration ne présente aucun danger.
- Ne pas souder dans des endroits situés à proximité d'opérations de dégraissage, de nettoyage ou de pulvérisation. La chaleur et les rayons de l'arc peuvent réagir en présence de vapeurs et former des gaz hautement toxiques et irritants.
- Ne pas souder des métaux munis d'un revêtement, tels que l'acier galvanisé, plaqué en plomb ou au cadmium à moins que le revêtement n'ait été enlevé dans la zone de soudure, que l'endroit soit bien ventilé, et en portant un respirateur à alimentation d'air. Les revêtements et tous les métaux renfermant ces éléments peuvent dégager des fumées toxiques en cas de soudage.



### LES ACCUMULATIONS DE GAZ risquent de provoquer des blessures ou même la mort.

- Fermer l'alimentation du gaz protecteur en cas de non utilisation.
- Veiller toujours à bien aérer les espaces confinés ou se servir d'un respirateur d'adduction d'air homologué.

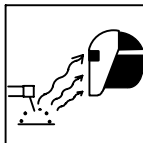

### LES RAYONS DE L'ARC peuvent provoquer des brûlures dans les yeux et sur la peau.

Le rayonnement de l'arc du procédé de soudage génère des rayons visibles et invisibles intenses (ultraviolets et infrarouges) susceptibles de provoquer des brûlures dans les yeux et sur la peau. Des étincelles sont projetées pendant le soudage.

- Porter un casque de soudage approuvé muni de verres filtrants appropriés pour protéger visage et yeux pendant le soudage (voir ANSI Z49.1 et Z87.1 énuméré dans les normes de sécurité).
- Porter des lunettes de sécurité avec écrans latéraux même sous votre casque.
- Avoir recours à des écrans protecteurs ou à des rideaux pour protéger les autres contre les rayonnements les éblouissements et les étincelles; prévenir toute personne sur les lieux de ne pas regarder l'arc.
- Porter des vêtements confectionnés avec des matières résistantes et ignifuges (cuir, coton lourd ou laine) et des bottes de protection.



### LE SOUDAGE peut provoquer un incendie ou une explosion.

Le soudage effectué sur des conteneurs fermés tels que des réservoirs, tambours ou des conduites peut provoquer leur éclatement. Des étincelles peuvent être projetées de l'arc de soudure. La projection d'étincelles, des pièces chaudes et des équipements chauds peut provoquer des incendies et des brûlures. Le contact accidentel de l'électrode avec des objets métalliques peut provoquer des étincelles, une explosion, un surchauffement ou un incendie. Avant de commencer le soudage, vérifier et s'assurer que l'endroit ne présente pas de danger.

- Déplacer toutes les substances inflammables à une distance de 10,7 m de l'arc de soudage. En cas d'impossibilité les recouvrir soigneusement avec des protections homologués.
- Ne pas souder dans un endroit où des étincelles peuvent tomber sur des substances inflammables.
- Se protéger et d'autres personnes de la projection d'étincelles et de métal chaud.
- Des étincelles et des matériaux chauds du soudage peuvent facilement passer dans d'autres zones en traversant de petites fissures et des ouvertures.
- Surveiller tout déclenchement d'incendie et tenir un extincteur à proximité.
- Le soudage effectué sur un plafond, plancher, paroi ou séparation peut déclencher un incendie de l'autre côté.
- Ne pas effectuer le soudage sur des conteneurs fermés tels que des réservoirs, tambours, ou conduites, à moins qu'ils n'aient été préparés correctement conformément à AWS F4.1 (voir les normes de sécurité).
- Brancher le câble sur la pièce le plus près possible de la zone de soudage pour éviter le transport du courant sur une longue distance par des chemins inconnus éventuels en provoquant des risques d'électrocution et d'incendie.
- Brancher le câble de masse sur la pièce le plus près possible de la zone de soudage pour éviter le transport du courant sur une longue distance par des chemins inconnus éventuels en provoquant des risques d'électrocution, d'étincelles et d'incendie.
- Ne pas utiliser le poste de soudage pour dégeler des conduites gelées.
- En cas de non utilisation, enlever la baguette d'électrode du porte-électrode ou couper le fil à la pointe de contact.
- Porter des vêtements de protection dépourvus d'huile tels que des gants en cuir, une chemise en matériau lourd, des pantalons sans revers, des chaussures hautes et un couvre chef.
- Avant de souder, retirer toute substance combustible de vos poches telles qu'un allumeur au butane ou des allumettes.
- Suivre les recommandations dans OSHA 1910.252(a)(2)(iv) et NFPA 51B pour les travaux à chaud et avoir de la surveillance et un extincteur à proximité.

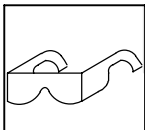

### DES PARTICULES VOLANTES peuvent blesser les yeux.

- Le soudage, l'écaillage, le passage de la pièce à la brose en fil de fer, et le meulage génèrent des étincelles et des particules métalliques volantes. Pendant la période de refroidissement des soudures, elles risquent de projeter du laitier.

- Porter des lunettes de sécurité avec écrans latéraux ou un écran facial.



### DES PIÈCES CHAUDES peuvent provoquer des brûlures graves.

- Ne pas toucher à mains nues les parties chaudes.
- Prévoir une période de refroidissement avant de travailler à l'équipement.
- Ne pas toucher aux pièces chaudes, utiliser les outils recommandés et porter des gants de soudage et des vêtements épais pour éviter les brûlures.

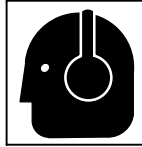

### LE BRUIT peut affecter l'ouïe.

Le bruit des processus et des équipements peut affecter l'ouïe.

- Porter des protections approuvés pour les oreilles si le niveau sonore est trop élevé.



### LES CHAMPS MAGNÉTIQUES peuvent affecter les stimulateurs cardiaques.

- Porteurs de stimulateur cardiaque, restez à distance.
- Les porteurs d'un stimulateur cardiaque doivent d'abord consulter leur médecin avant de s'approcher des opérations de soudage à l'arc, de gougeage ou de soudage par points.

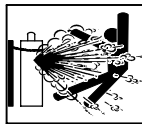

### Si des BOUTEILLES sont endommagées, elles pourront exploser.

Des bouteilles de gaz protecteur contiennent du gaz sous haute pression. Si une bouteille est endommagée, elle peut exploser. Du fait que les bouteilles de gaz font normalement partie du procédé de soudage, les manipuler avec précaution.

- Protéger les bouteilles de gaz comprimé d'une chaleur excessive, des chocs mécaniques, des dommages physiques, du laitier, des flammes ouvertes, des étincelles et des arcs.
- Placer les bouteilles debout en les fixant dans un support stationnaire ou dans un porte-bouteilles pour les empêcher de tomber ou de se renverser.
- Tenir les bouteilles éloignées des circuits de soudage ou autres circuits électriques.
- Ne jamais placer une torche de soudage sur une bouteille à gaz.
- Une électrode de soudage ne doit jamais entrer en contact avec une bouteille.
- Ne jamais souder une bouteille pressurisée – risque d'explosion.
- Utiliser seulement des bouteilles de gaz protecteur, régulateurs, tuyaux et raccords convenables pour cette application spécifique; les maintenir ainsi que les éléments associés en bon état.
- Ne pas tenir la tête en face de la sortie en ouvrant la soupape de la bouteille.
- Maintenir le chapeau de protection sur la soupape, sauf en cas d'utilisation ou de branchement de la bouteille.
- Utiliser les équipements corrects, les bonnes procédures et suffisamment de personnes pour soulever et déplacer les bouteilles.
- Lire et suivre les instructions sur les bouteilles de gaz comprimé, l'équipement connexe et le dépliant P-1 de la CGA (Compressed Gas Association) mentionné dans les principales normes de sécurité.

## 2-3. Dangers existant en relation avec le moteur

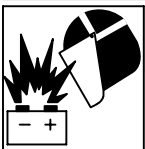

### L'EXPLOSION DE LA BATTERIE peut RENDRE AVEUGLE.

- Toujours porter une protection faciale, des gants en caoutchouc et vêtements de protection lors d'une intervention sur la batterie.

- Arrêter le moteur avant de débrancher ou de brancher les câbles de batterie.
- Éviter de provoquer des étincelles avec les outils en travaillant sur la batterie.
- Ne pas utiliser le poste de soudage pour charger les batteries ou des véhicules de démarrage rapide.
- Observer la polarité correcte (+ et -) sur les batteries.
- Débrancher le câble négatif (-) en premier lieu. Le rebrancher en dernier lieu.



### LE CARBURANT MOTEUR peut provoquer un incendie ou une explosion.

- Arrêter le moteur avant de vérifier le niveau de carburant ou de faire le plein.

- Ne pas faire le plein en fumant ou proche d'une source d'étincelles ou d'une flamme nue.
- Ne pas faire le plein de carburant à ras bord; prévoir de l'espace pour son expansion.
- Faire attention de ne pas renverser de carburant. Nettoyer tout carburant renversé avant de faire démarrer le moteur.
- Jeter les chiffons dans un récipient ignifuge.



### DES ORGANES MOBILES peuvent provoquer des blessures.

- Ne pas approcher les mains des ventilateurs, courroies et autres pièces en mouvement.

- Maintenir fermés et fixement en place les portes, panneaux, recouvrements et dispositifs de protection.



### DES PIÈCES CHAUDES peuvent provoquer des brûlures et blessures.

- Ne pas toucher les parties chaudes du moteur.
- Laisser l'ensemble se refroidir avant d'effectuer la maintenance.

- Porter des gants et des vêtements de protection pour travailler sur un moteur chaud.

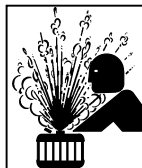

### LA VAPEUR ET LE LIQUIDE DE REFROIDISSEMENT CHAUD peuvent provoquer des brûlures.

- Il est préférable de vérifier le liquide de refroidissement une fois le moteur refroidi pour éviter de se brûler.

- Toujours vérifier le niveau de liquide de refroidissement dans le vase d'expansion (si présent), et non dans le radiateur (sauf si précisé autrement dans la section maintenance du manuel du moteur).

- Si le moteur est chaud et que le liquide doit être vérifié, opérer comme suivant.
- Mettre des lunettes de sécurité et des gants, placer un torchon sur le bouchon du radiateur.
- Dévisser le bouchon légèrement et laisser la vapeur s'échapper avant d'enlever le bouchon.



### LES ACCUMULATIONS DE GAZ risquent de provoquer des blessures ou même la mort.

- Fermer l'alimentation du gaz protecteur en cas de non utilisation.
- Veiller toujours à bien aérer les espaces confinés ou se servir d'un respirateur d'adduction d'air homologué.

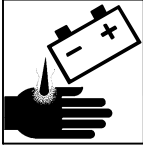

### L'ACIDE DE LA BATTERIE peut provoquer des brûlures dans les YEUX et sur la PEAU.

- Ne pas renverser la batterie.
- Remplacer une batterie endommagée.
- Rincer immédiatement les yeux et la peau à l'eau.



- Ne pas placer l'appareil sur, au-dessus ou à proximité de surfaces inflammables.
- Tenir à distance les produits inflammables de l'échappement.



### LES ÉTINCELLES À L'ÉCHAPPEMENT peuvent provoquer un incendie.

- Empêcher les étincelles d'échappement du moteur de provoquer un incendie.
- Utiliser uniquement un pare-étincelles approuvé – voir codes en vigueur.

## 2-4. Dangers liés à l'air comprimé



### RESPIRER L'AIR COMPRIMÉ peut provoquer des blessures graves ou causer la mort.

- Ne pas utiliser l'air comprimé pour respirer.
- Utiliser l'air comprimé seulement pour le coupage, gougeage et les outils pneumatiques.

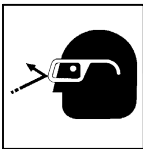

### L'AIR COMPRIMÉ peut provoquer des blessures.

- Porter des lunettes de sécurité approuvées.
- Ne pas diriger le jet d'air vers d'autres ou soi-même.



### L'AIR COMPRIÉ EMMAGASINE ET DES TUYAUX SOUS PRESSION peuvent provoquer des blessures.

- Relâcher la pression d'air de l'outillage ou du système avant d'effectuer la maintenance, avant de changer ou de rajouter des éléments ou avant d'ouvrir la purge ou le bouchon de remplissage d'huile.



### Le METAL CHAUD lors du coupage et gougeage plasma peut provoquer un incendie ou une explosion.

- Ne pas couper ou gouger à proximité de produits inflammables.
- Surveillez et garder un extincteur à proximité.



### DES PIÈCES CHAUDES peuvent provoquer des brûlures et blessures.

- Ne pas toucher le compresseur ou d'autres éléments du circuit air comprimé chauds.
- Laisser l'ensemble se refroidir avant de toucher ou d'effectuer la maintenance.

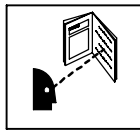

### LIRE LES INSTRUCTIONS.

- Lisez le manuel d'instructions avant l'utilisation ou la maintenance de l'appareil.
- Arrêter le moteur et relâcher la pression avant d'effectuer la maintenance.
- Utiliser uniquement des pièces de rechange Miller/Hobart.

## 2-5. Dangers supplémentaires en relation avec l'installation, le fonctionnement et la maintenance

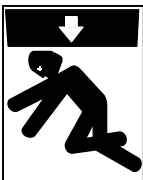

### LA CHUTE DE L'APPAREIL peut blesser.

- Utiliser un œilleton de levage pour lever l'appareil et les accessoires correctement installés. Ne pas dépasser le poids nominal maximal de l'œilleton (voir les spécifications).
- Ne lever et ne soutenir l'appareil qu'avec de l'équipement approprié et en suivant les procédures adéquates.

- En utilisant des fourches de levage pour déplacer l'unité, s'assurer que les fourches sont suffisamment longues pour dépasser du côté opposé de l'appareil.

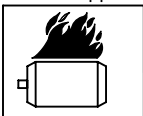

### LE SURCHAUFFEMENT peut endommager le moteur électrique.

- Arrêter ou déconnecter l'équipement avant de démarrer ou d'arrêter le moteur.

- Ne pas laisser tourner le moteur trop lentement sous risque d'endommager le moteur électrique à cause d'une tension et d'une fréquence trop faibles.
- Ne pas brancher de moteur de 50 ou de 60 Hz à la prise de 100 Hz, s'il y a lieu.

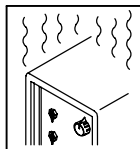

### L'EMPLOI EXCESSIF peut SURCHAUFFER L'ÉQUIPEMENT.

- Laisser l'équipement refroidir ; respecter le facteur de marche nominal.
- Réduire le courant ou le facteur de marche avant de poursuivre le soudage.
- Ne pas obstruer les passages d'air du poste.

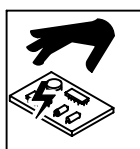

### LES CHARGES ÉLECTROSTATIQUES peuvent endommager les circuits imprimés.

- Établir la connexion avec la barrette de terre avant de manipuler des cartes ou des pièces.

- Utiliser des pochettes et des boîtes antistatiques pour stocker, déplacer ou expédier des cartes de circuits imprimés.

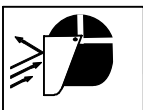

### LES ÉTINCELLES VOLANTES risquent de provoquer des blessures.

- Porter un écran facial pour protéger le visage et les yeux.

- Affûter l'électrode au tungstène uniquement à la meuleuse dotée de protecteurs. Cette manœuvre est à exécuter dans un endroit sûr lorsque l'on porte l'équipement homologué de protection du visage, des mains et du corps.
- Les étincelles risquent de causer un incendie – éloigner toute substance inflammable.



### UNE REMORQUE QUI BASCULE peut entraîner des blessures.

- Utiliser les supports de la remorque ou des blocs pour soutenir le poids.
- Installer convenablement le poste sur la remorque comme indiqué dans le manuel s'y rapportant.

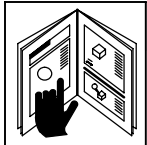

### LIRE LES INSTRUCTIONS.

- Utiliser seulement les pièces de rechange d'origine.
- Effectuer la maintenance du moteur et du compresseur (si applicable) suivant ce manuel et le manuel du moteur/compresseur (si applicable).

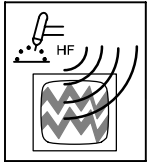

### LE RAYONNEMENT HAUTE FRÉQUENCE (H.F.) risque de provoquer des interférences.

- Le rayonnement haute fréquence (H.F.) peut provoquer des interférences avec les équipements de radio-navigation et de communication, les services de sécurité et les ordinateurs.

- Demander seulement à des personnes qualifiées familiarisées avec des équipements électroniques de faire fonctionner l'installation.
- L'utilisateur est tenu de faire corriger rapidement par un électricien qualifié les interférences résultant de l'installation.
- Si le FCC signale des interférences, arrêter immédiatement l'appareil.
- Effectuer régulièrement le contrôle et l'entretien de l'installation.
- Maintenir soigneusement fermés les portes et les panneaux des sources de haute fréquence, maintenir les éclateurs à une distance correcte et utiliser une terre et un blindage pour réduire les interférences éventuelles.

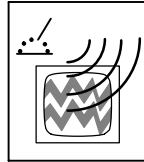

### LE SOUDAGE À L'ARC risque de provoquer des interférences.

- L'énergie électromagnétique risque de provoquer des interférences pour l'équipement électronique sensible tel que les ordinateurs et l'équipement commandé par ordinateur tel que les robots.

- Veiller à ce que tout l'équipement de la zone de soudage soit compatible électromagnétiquement.
- Pour réduire la possibilité d'interférence, maintenir les câbles de soudage aussi courts que possible, les grouper, et les poser aussi bas que possible (ex. par terre).
- Veiller à souder à une distance de 100 mètres de tout équipement électronique sensible.
- Veiller à ce que ce poste de soudage soit posé et mis à la terre conformément à ce mode d'emploi.
- En cas d'interférences après avoir pris les mesures précédentes, il incombe à l'utilisateur de prendre des mesures supplémentaires telles que le déplacement du poste, l'utilisation de câbles blindés, l'utilisation de filtres de ligne ou la pose de protecteurs dans la zone de travail.

## 2-6. Proposition californienne 65 Avertissements

- ▲ Les équipements de soudage et de coupage produisent des fumées et des gaz qui contiennent des produits chimiques dont l'État de Californie reconnaît qu'ils provoquent des malformations congénitales et, dans certains cas, des cancers. (Code de santé et de sécurité de Californie, chapitre 25249.5 et suivants)
- ▲ Les batteries, les bornes et autres accessoires contiennent du plomb et des composés à base de plomb, produits chimiques dont l'État de Californie reconnaît qu'ils provoquent des cancers et des malformations congénitales ou autres problèmes de procréation. Se laver les mains après manipulation.

#### Pour les moteurs à essence :

- ▲ Les gaz d'échappement des moteurs contiennent des produits chimiques dont l'État de Californie reconnaît qu'ils provoquent des cancers et des malformations congénitales ou autres problèmes de procréation.

#### Pour les moteurs diesel :

- ▲ Les gaz d'échappement des moteurs diesel et certains de leurs composants sont reconnus par l'État de Californie comme provoquant des cancers et des malformations congénitales ou autres problèmes de procréation.

## 2-7. Principales normes de sécurité

*Safety in Welding, Cutting, and Allied Processes*, ANSI Standard Z49.1, de Global Engineering Documents (téléphone : 1-877-413-5184, site Internet : [www.global.ihs.com](http://www.global.ihs.com)).

*Recommended Safe Practices for the Preparation for Welding and Cutting of Containers and Piping*, American Welding Society Standard AWS F4.1 de Global Engineering Documents (téléphone : 1-877-413-5184, site Internet : [www.global.ihs.com](http://www.global.ihs.com)).

*National Electrical Code*, NFPA Standard 70, de National Fire Protection Association, P.O. Box 9101, 1 Battery March Park, Quincy, MA 02269-9101 (téléphone : 617-770-3000, site Internet : [www.nfpa.org](http://www.nfpa.org)).

*Safe Handling of Compressed Gases in Cylinders*, CGA Pamphlet P-1, de Compressed Gas Association, 1735 Jefferson Davis Highway, Suite 1004, Arlington, VA 22202-4102 (téléphone : 703-412-0900, site Internet : [www.cganet.com](http://www.cganet.com)).

*Code for Safety in Welding and Cutting*, CSA Standard W117.2, de Canadian Standards Association, Standards Sales, 178 Rexdale

Boulevard, Rexdale, Ontario, Canada M9W 1R3 (téléphone : 800-463-6727 ou à Toronto 416-747-4044, site Internet : [www.csa-international.org](http://www.csa-international.org)).

*Practice For Occupational And Educational Eye And Face Protection*, ANSI Standard Z87.1, de American National Standards Institute, 11 West 42nd Street, New York, NY 10036-8002 (téléphone : 212-642-4900, site Internet : [www.ansi.org](http://www.ansi.org)).

*Standard for Fire Prevention During Welding, Cutting, and Other Hot Work*, NFPA Standard 51B, de National Fire Protection Association, P.O. Box 9101, 1 Battery March Park, Quincy, MA 02269-9101 (téléphone : 617-770-3000, site Internet : [www.nfpa.org](http://www.nfpa.org)).

OSHA, Occupational Safety and Health Standards for General Industry, Title 29, Code of Federal Regulations (CFR), Part 1910, Subpart Q, and Part 1926, Subpart J, de U.S. Government Printing Office, Superintendent of Documents, P.O. Box 371954, Pittsburgh, PA 15250 (il y a 10 bureaux régionaux—le téléphone de la région 5, Chicago, est 312-353-2220, site Internet : [www.osha.gov](http://www.osha.gov)).

## 2-8. Information EMF

Considérations sur le soudage et les effets de basse fréquence et des champs magnétiques et électriques.

Le courant de soudage, pendant son passage dans les câbles de soudage, causera des champs électromagnétiques. Il y a eu et il y a encore un certain souci à propos de tels champs. Cependant, après avoir examiné plus de 500 études qui ont été faites pendant une période de recherche de 17 ans, un comité spécial ruban bleu du National Research Council a conclu : « L'accumulation de preuves, suivant le jugement du comité, n'a pas démontré que l'exposition aux champs magnétiques et champs électriques à haute fréquence représente un risque à la santé humaine ». Toutefois, des études sont toujours en cours et les preuves continuent à être examinées. En attendant que les conclusions finales de la recherche soient établies, il vous serait souhaitable de réduire votre exposition aux champs électromagnétiques pendant le soudage ou le coupage.

Pour réduire les champs magnétiques sur le poste de travail, appliquer les

procédures suivantes :



















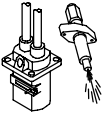
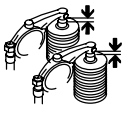





1. Maintenir les câbles ensemble en les tordant ou en les enveloppant.
2. Disposer les câbles d'un côté et à distance de l'opérateur.
3. Ne pas courber pas et ne pas entourer pas les câbles autour de votre corps.
4. Garder le poste de soudage et les câbles le plus loin possible de vous.
5. Connecter la pince sur la pièce aussi près que possible de la soudure.

#### En ce qui concerne les stimulateurs cardiaques

Les porteurs de stimulateur cardiaque doivent consulter leur médecin avant de souder ou d'approcher des opérations de soudage. Si le médecin approuve, il est recommandé de suivre les procédures précédentes.

# SECTION 3 – DEFINITIONS

## 3-1. Symbols And Definitions

	Stop Engine		Start Engine		Ether Starting Aid		Engine
	Do Not Switch While Welding Or Under Load		Battery (Engine)		Circuit Breaker		Engine Oil
	Check Injectors/ Pump		Check Valve Clearance		Fuel		Protective Earth (Ground)
<b>+</b>	Positive	<b>-</b>	Negative		Certified/Trained Mechanic		Welding Arc
<b>A</b>	Amperes	<b>V</b>	Volts		Panel/Local		Remote
<b>I</b>	On		Temperature		Output (Contactor)		Alternating Current
	Stick (SMAW) Welding		TIG (GTAW) Welding		MIG (GMAW) Welding	<b>3</b> 	Three Phase
	Time	<b>h</b>	Hours	<b>S</b>	Seconds	<b>1</b> 	Single Phase
			Read Operator's Manual				

# SECTION 4 – SPECIFICATIONS

## 4-1. Description

This unit has two CC/CV modules with separate weld controls for applications where two welding arcs are needed. A Welder Selector switch controls whether one or both sets of weld output terminals are active (see Section 6-2). When the unit is operated in the dual operator mode, each welder has CC and CV weld output available for Stick, TIG, and MIG welding. When in the single operator mode, CC weld output is available to the welder on the Welder B (right) side only (CV not active in single operator mode).

## 4-2. Weld, Power, And Engine Specifications

Weld Mode	Weld Stations Available	Weld Output	Weld Output Range	Max. Open-Circuit Voltage	Rated Welding Output	Generator Power Rating	Engine	Fuel Capacity
Single	1 (Right Side)	CC/DC	30 – 600 A	85	550 A at 30 Volts DC, 40% Duty Cycle	Single-Phase, 4 kVA/kW, 34/17 A, 120/240 V AC, 50/60 Hz (4 kVA/kW Shared By All Receptacles)	Deutz F3L-912 Air-Cooled, Three-Cylinder, 41.5 HP Diesel Engine	22.3 gal (84.4 L)
Dual	2 (Both Sides)	CC/DC	15 – 300 A	85	275 A at 31 Volts DC, 40% Duty Cycle			
		CV/DC	10 – 32 V	49				

## 4-3. Dimensions, Weights, And Operating Angles

Dimensions	
Height	47-5/8 in (1210 mm)
Width	31-1/4 in (794 mm)
Depth	60-1/2 in (1537 mm)
A	59-1/8 in (1502 mm)
B	47-1/4 in (1200 mm)
C	43-1/4 in (1099 mm)
D	32-3/4 in (832 mm)
E	24-15/16 in (633 mm)
F	10-1/2 in (267 mm)
G	6-1/2 in (165 mm)
H	2-7/8 in (73 mm)
J	29-7/8 in (759 mm)
K	11/16 in (24 mm)
L	21/32 in (17 mm) Dia. 16 Holes
Weight	
2005 lb (909 kg)	
<b>Lifting Eye Weight Rating:</b> 2161 lb (980 kg) Maximum	

▲ Do not exceed tilt angles or engine could be damaged or unit could tip.

▲ Do not move or operate unit where it could tip.

angles\_1 8/99

#### 4-4. Fuel Consumption

The curve shows typical fuel use under the combined weld loads of both sides (Welder A and Welder B).

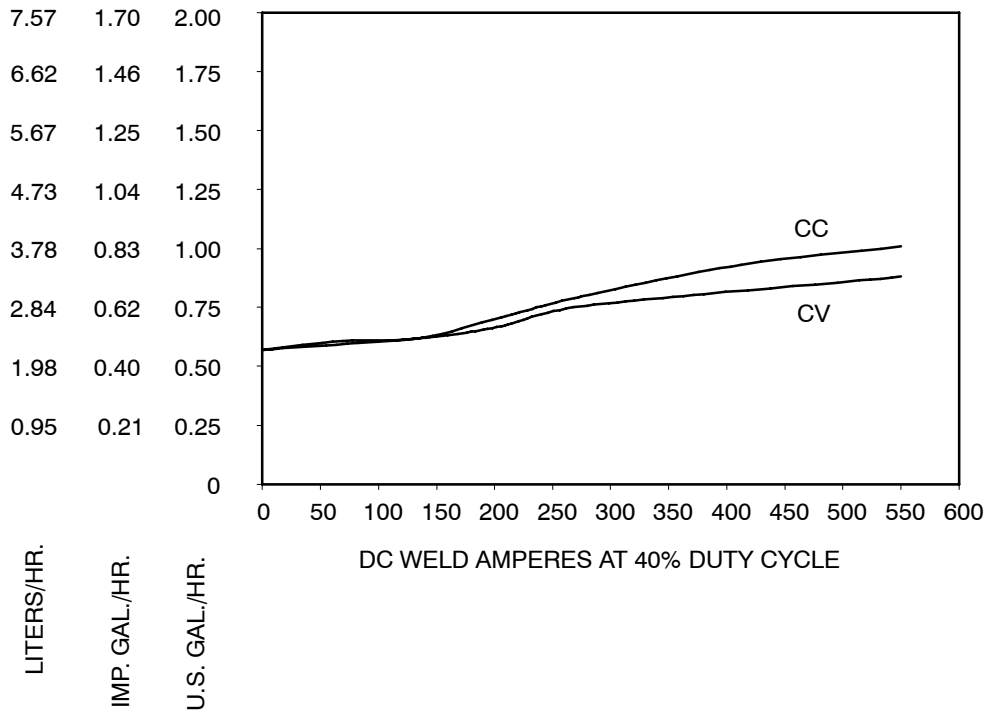

195 711

#### 4-5. AC Generator Power

The ac power curve shows the generator power in amperes available at the 120 and 240 volt receptacles.

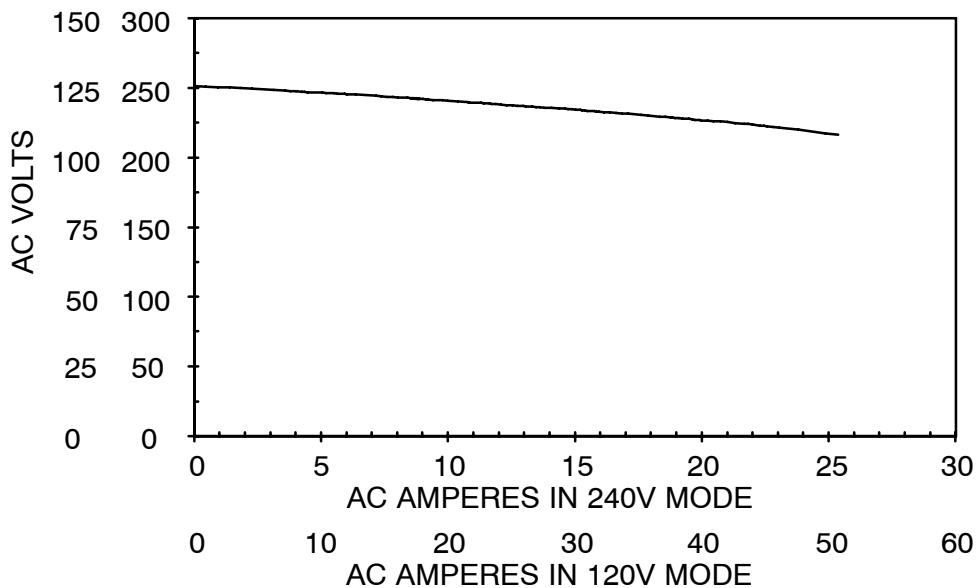

193 018

## 4-6. Duty Cycle And Overheating

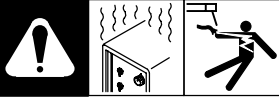

Dual Operator Mode – 40% Duty Cycle At 275 Amperes From Each Side  
 Single Operator Mode – 40% Duty Cycle At 550 Amperes From Welder B side (Right)

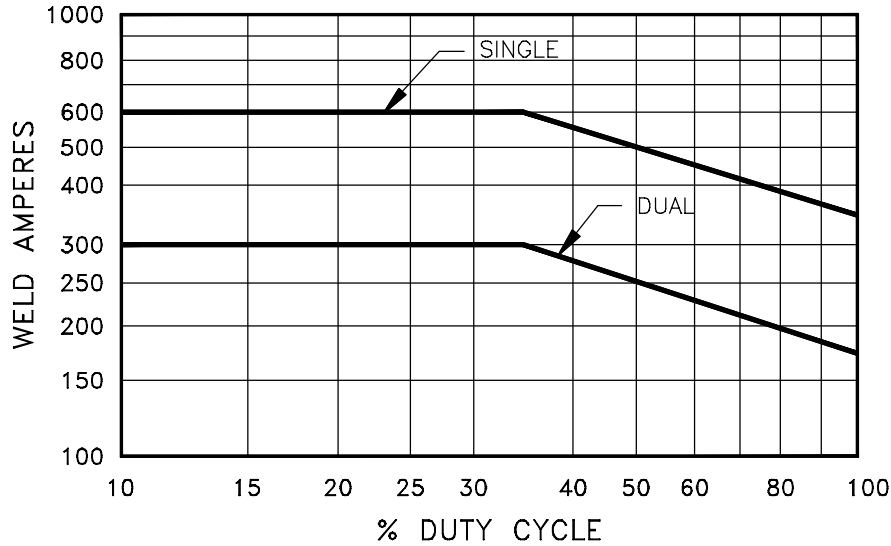
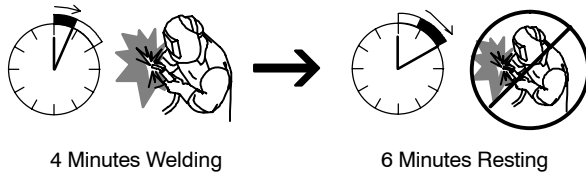

Duty Cycle is percentage of 10 minutes that unit can weld at rated load without overheating.

▲ Exceeding duty cycle can damage unit and void warranty.

If a weld module overheats, the High Temperature light goes on and the thermostat opens to stop weld output to that module. Wait fifteen minutes for module to cool. Reduce amperage, voltage, or duty cycle before welding.

This unit has separate duty cycle ratings for each operating mode. If the unit is operated in the dual operator mode, the unit is rated at 40% duty cycle. This means each side of the unit can be operated at 275 amperes at 40% duty cycle.

When the unit is operated in the single operator mode, the Welder B side (right) is rated at 40% duty cycle (550 A at 40% duty cycle).

### Overheating

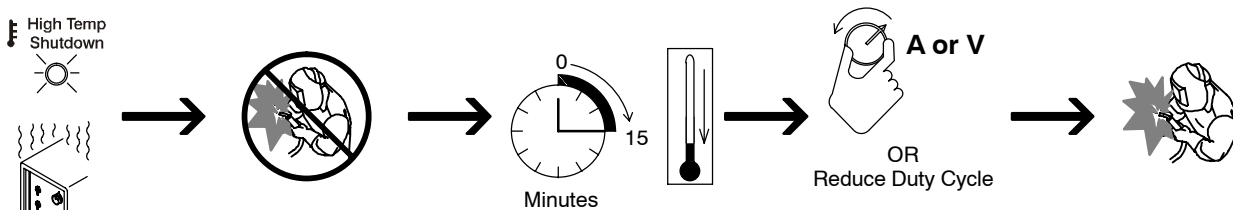

Ref. r duty1 5/95 – 194 313-A



## 4-7. Volt-Ampere Curves

### A. CC/DC - Single Mode

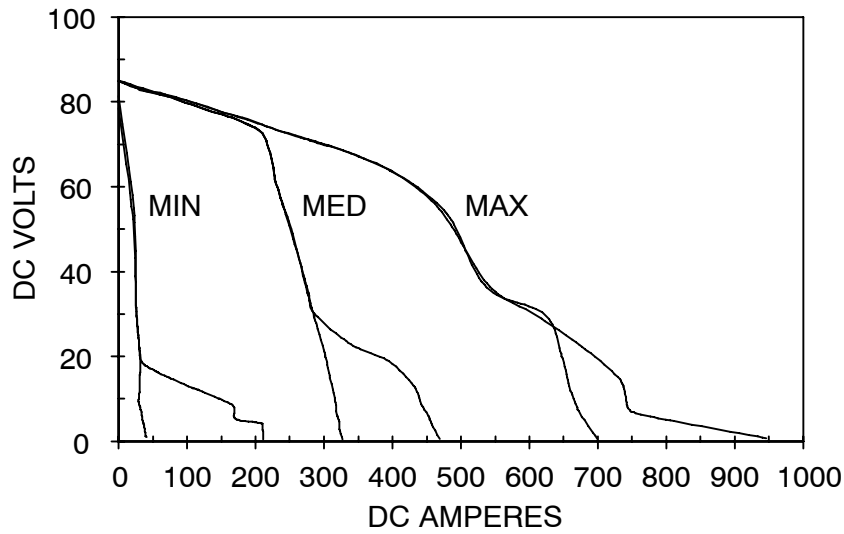

The volt-ampere curve shows the minimum, medium, and maximum voltage and amperage output capabilities of the welding generator. Curves of all other settings fall between the curves shown.

### B. CC/DC - Dual Mode

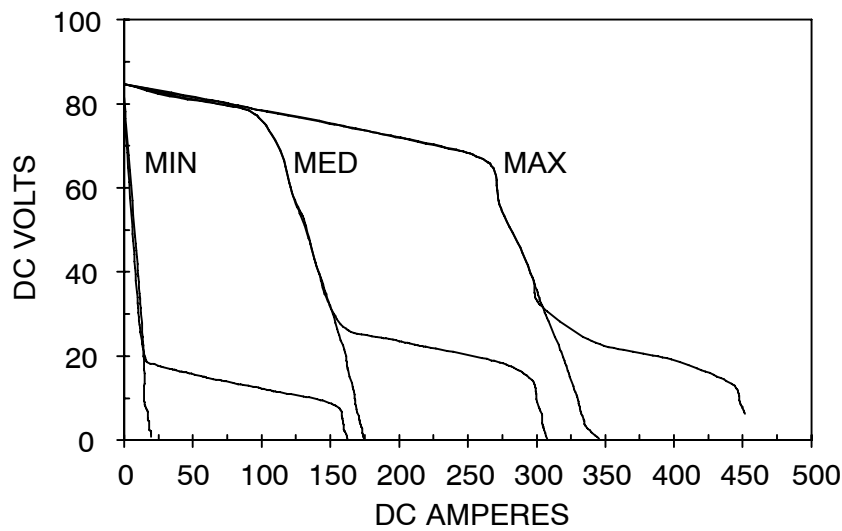

### C. CV/DC Mode

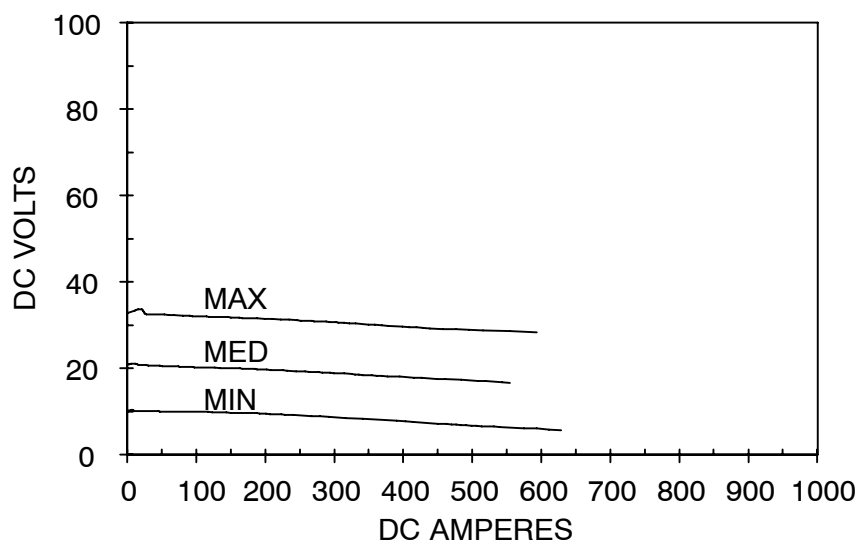

# SECTION 5 – INSTALLATION

## NOTE

When facing the front panel, the Welder B controls and weld terminals are on the right and the Welder A controls and weld terminals are on the left.

### 5-1. Installing Welding Generator



#### Movement

▲ Do Not Lift Unit From End

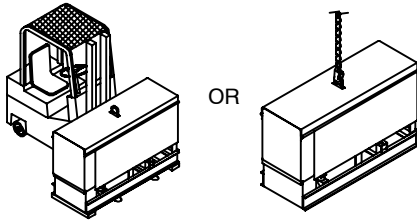

#### Airflow Clearance

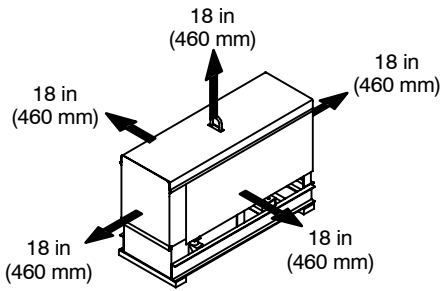

#### Location

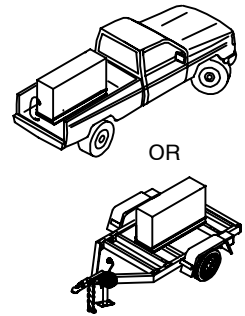

#### Grounding

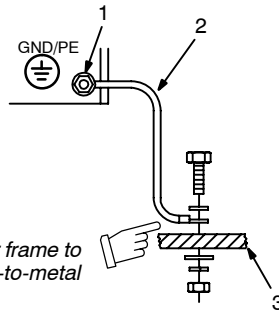

Electrically bond generator frame to vehicle frame by metal-to-metal contact.

▲ Bed liners, shipping skids, and some running gears insulate the welding generator from the vehicle frame. Always connect a ground wire from the generator equipment grounding terminal to bare metal on the vehicle frame as shown.

▲ Always securely fasten welding generator onto transport vehicle or trailer and comply with all DOT and other applicable codes.

▲ Always ground generator frame to vehicle frame to prevent electric shock and static electricity hazards.

▲ If unit does not have GFCI receptacles, use GFCI-protected extension cord.

- 1 Equipment Grounding Terminal (On Front Panel)
- 2 Grounding Cable (Not Supplied)
- 3 Metal Vehicle Frame

Connect cable from equipment ground terminal to metal vehicle frame. Use #10 AWG or larger insulated copper wire.

▲ Be sure equipment connected to the 240 V receptacles is GFCI-protected.

install1 11/02\* – Ref. ST-800 652 / Ref. ST-800 477-A / ST-158 936-A / S-0854

## Notes

---

---

---

---

---

---

---

---

---

---

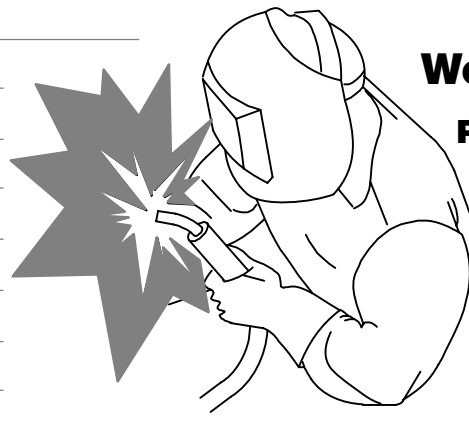

**Work like a Pro!**  
**Pros weld and cut safely. Read the safety rules at the beginning of this manual.**

## 5-2. Activating The Dry Charge Battery (If Applicable)

**Tools Needed:**

**▲ Always wear a face shield, rubber gloves and protective clothing when working on a battery.**

Remove battery from unit.

- Vent Caps
- Sulfuric Acid Electrolyte (1.265 Specific Gravity)
- Well

Fill each cell with electrolyte to **bottom** of well (maximum).

**▲ Do not overfill battery cells.**

Wait ten minutes and check electrolyte level. If necessary, add electrolyte to raise to proper level. Reinstall vent caps.

- Battery Charger

**▲ Read and follow all instructions supplied with battery charger.**

Charge battery for 12 minutes at 30 amperes or 30 minutes at 5 amperes. Disconnect charging cables and install battery.

*When electrolyte is low, add only distilled water to cells to maintain proper level.*

drybatt1 6/05 - S-0886

## 5-3. Connecting The Battery

**▲ Connect (-) Cable Last.**

190 377

## 5-4. Installing Exhaust Pipe



▲ Stop engine and let cool.

▲ Do not blow exhaust toward air cleaner or air intake.

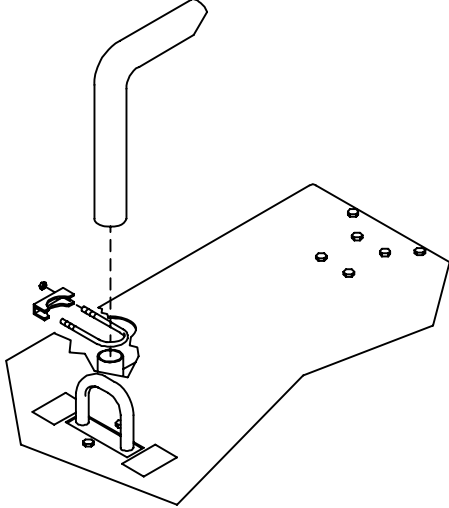

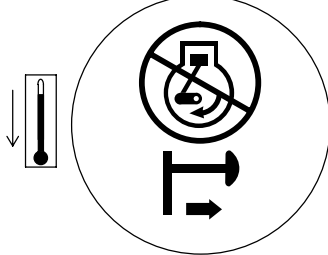

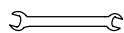
Tools Needed:  
 1/2 in

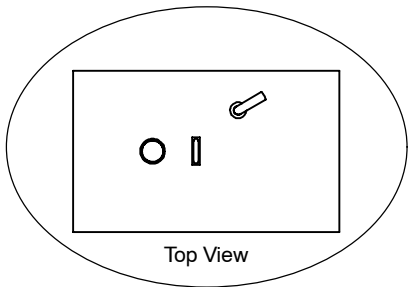

Top View

exh\_pipe2 4/96 - 154 089-A / 154 611 / 190 377

## 5-5. Engine Prestart Checks



Check all fluids daily. Engine must be cold and on a level surface.

Follow run-in procedure in engine manual. If unburned fuel and oil collect in exhaust pipe during run-in, see Section 10.

**Fuel**

▲ Do not use gasoline. Gasoline will damage engine.

Add diesel fuel before starting engine the first time (see maintenance label for specifications). Fill fuel tank up to 1/2 in. (13 mm) from top to allow room for expansion. Open fuel shut-off valve.

Do not run out of fuel or air enters fuel system and causes starting problems. See engine manual to bleed air from fuel system.

**Oil**

After fueling, check oil with unit on level surface. If oil is not up to full mark on dipstick, add oil (see maintenance label).

☞ Engine stops if oil pressure is too low.

☞ To improve cold weather starting:

*Keep battery in good condition. Store battery in warm area.*

*Use fuel formulated for cold weather (diesel fuel can gel in cold weather). Contact local fuel supplier for fuel information.*

*Use correct grade oil for cold weather.*

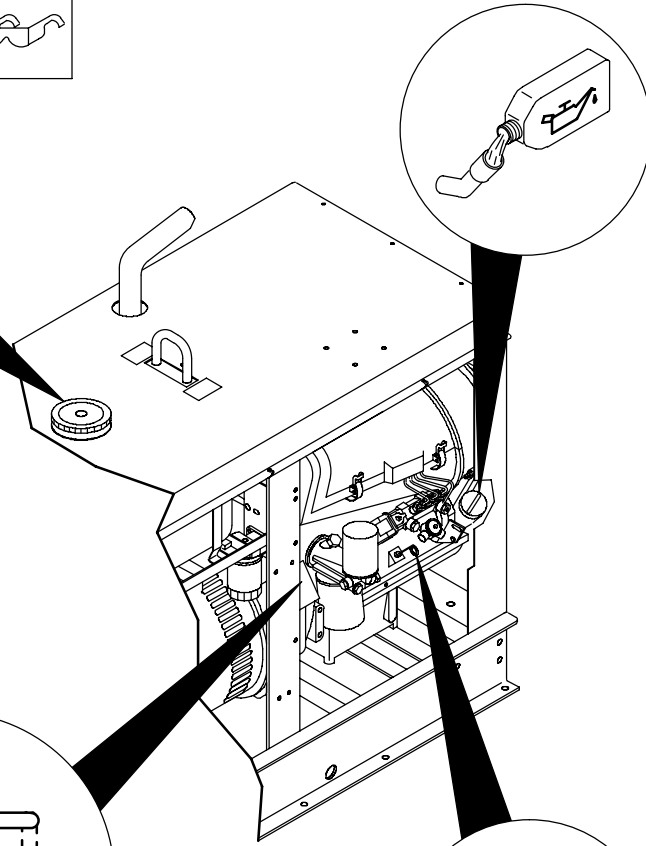

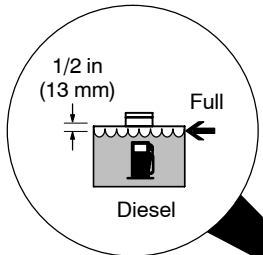

1/2 in (13 mm)  
Full  
Diesel

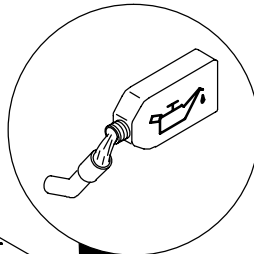

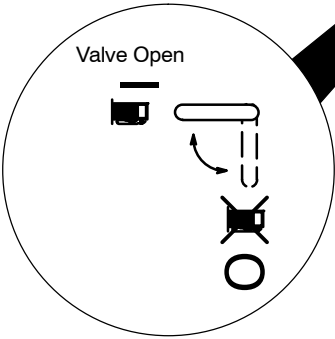

Valve Open

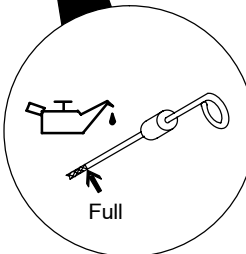

Full

Ref. 158 633-C / S-176 697

## 5-6. Safety Information For Connecting To Weld Output Terminals



### ▲ UNEXPECTED WELD OUTPUT can cause injury or fire.

- Both weld outputs can be live (ON) when Welder Selector switch is in Welder A/Welder B position and engine is running.
- Disconnect or insulate any unused cables.
- Know where cables are located BEFORE starting engine.

### ▲ ELECTRIC SHOCK can kill; ARCING can burn skin or damage electrical connections.

- Stop engine before making any weld output connections.
- Do not connect welding output of different polarities to the same structure.
- See ANSI Z49.1 and OSHA Title 29, Chapter XVII, Part 1910, Subpart Q (addresses at beginning of manual).
- When welding on the same workpiece, all connections to the workpiece must be of the same polarity.
- Do not handle or come in contact with two live electrodes at the same time.

### ▲ ELECTRIC SHOCK can kill; TWO TIMES NORMAL OPEN-CIRCUIT VOLTS can exist between electrode holders of opposite polarity.

- Do not touch electrode holders of opposite polarity at the same time.
- Separate electrode holders of opposite polarity to prevent contact.
- Consult ANSI Z49.1 for common grounding safe practices.

## 5-7. Weld Output Terminals

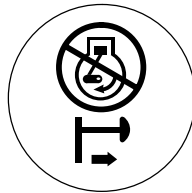

Welder A (Left) Side

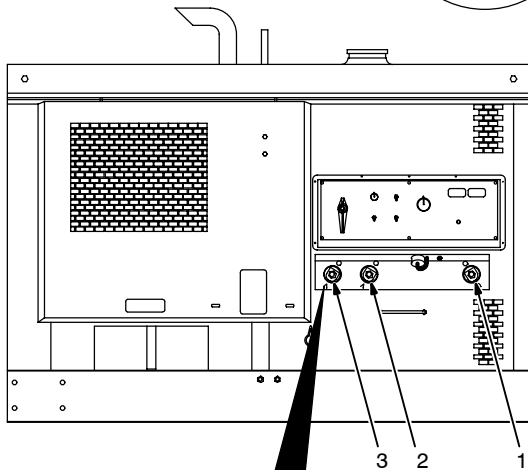

Welder B (Right) Side

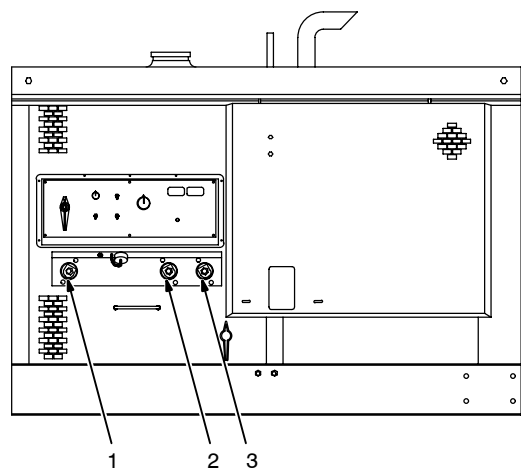

 Dinse receptacles only on units with Polarity switch option.

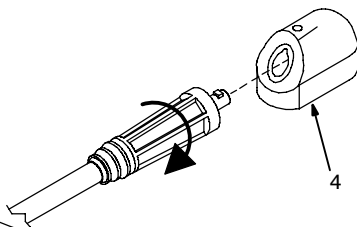

Tools Needed:

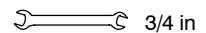

Ref. 190 377 / 802 292-A / 802 554

### ▲ Stop engine.

- 1 Negative (-) Weld Output Terminal
- 2 CV Weld Output Terminal
- 3 CC Weld Output Terminal

### 4 Dinse Weld Receptacles (Only On Units With Polarity Switch Option)

See Sections 5-8 thru 5-13 for dual operator output connections for CC and CV welding.

See Section 5-14 for single operator output

connections (CC only).

If unit has the Polarity switch option, the Negative (-) weld output terminals are labeled Work receptacles and the CC weld output terminals are labeled Electrode receptacles.

## 5-8. Making Dual Operator CC Weld Connections w/ Separate Work Cables

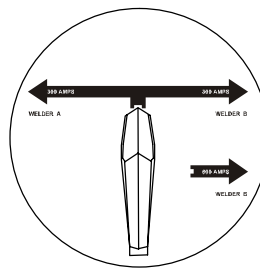
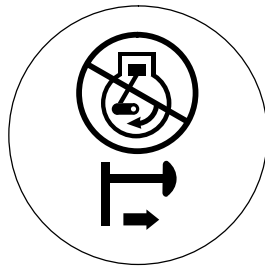

Tools Needed:

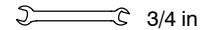

Direct Current Electrode Positive (DCEP) connections are shown.

Welder A (Left Side)

Welder B (Right Side)

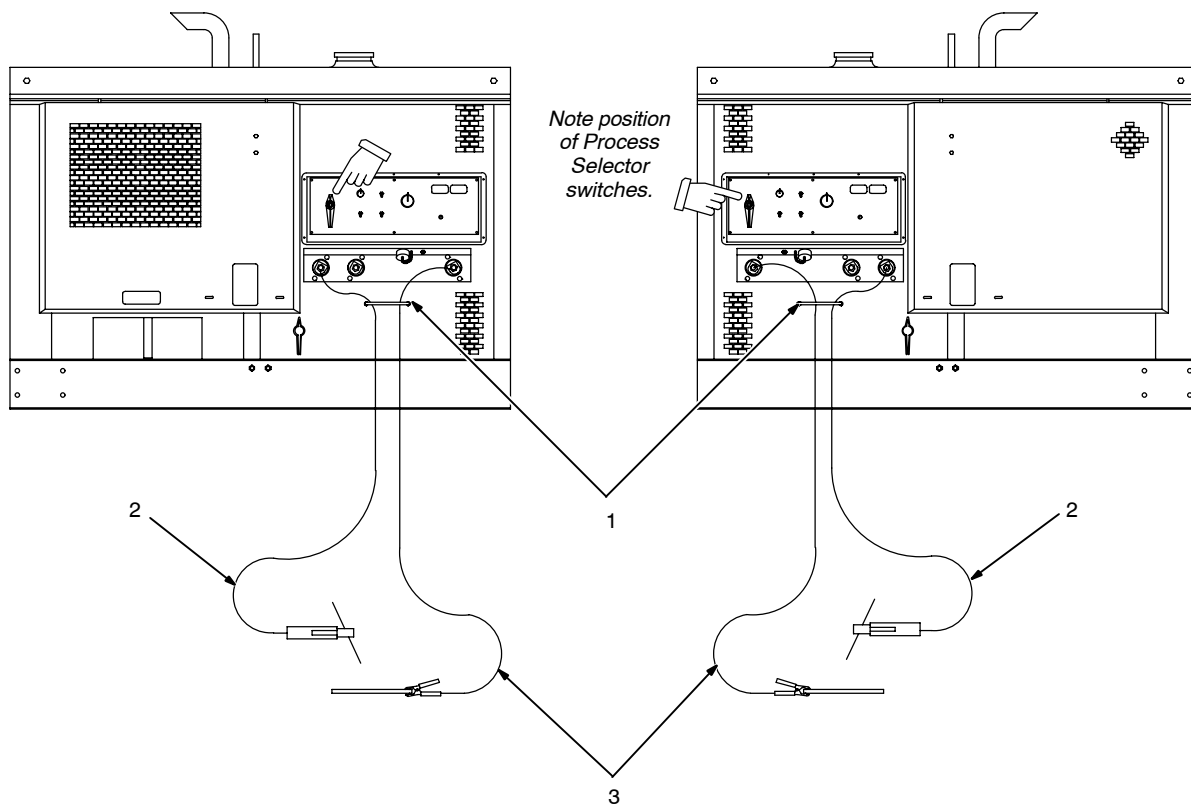

Ref. 190 377 / 802 292-A

▲ **Stop engine.**

▲ **Do not exceed machine duty cycle.**

☞ Use Dual Operator mode for CC and CV welding (see Section 6-1).

See Section 5-15 for proper cable size.

1 Strain Reliefs

Route cables through strain reliefs.

2 Electrode Holder Cables

3 Work Cables

For Stick/TIG welding Direct Current Electrode Positive (DCEP), connect work cables to Negative (-) terminals and electrode holder cables to CC terminals.

For Stick/TIG Direct Current Electrode Negative (DCEN), connect work cables to

CC terminals and electrode holder cables to Negative (-) terminals.

If unit has the Polarity switch option, connect work cables to Work receptacles and electrode holder cables to Electrode receptacles.

☞ Be sure Process Selector switches are set correctly. See Section 6-3.

## 5-9. Making Dual Operator Mode CC Weld Connections w/ Common Work Cable

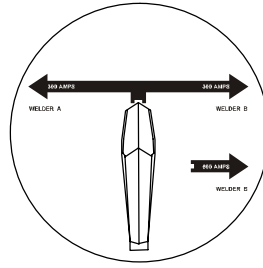
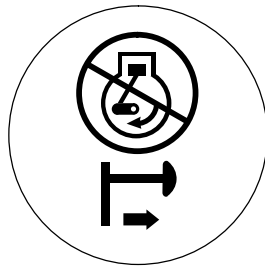

Tools Needed:

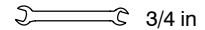

### ▲ INADEQUATE CABLE CONNECTIONS can cause serious damage to welding generator and create a hazardous condition.

When making weld connections with a common work cable, connect a weld cable of adequate size between the Negative (-) weld terminals, and connect a single weld cable of adequate size from the Welder B (right) Negative (-) terminal to the workpiece.

When using these connections as a common work terminal, all connections must be of the same polarity.

For a common work cable connection, the work cable must be able to carry the combined weld output of both modules (see Section 5-15 for proper cable size).

 Direct Current Electrode Positive (DCEP) connections are shown.

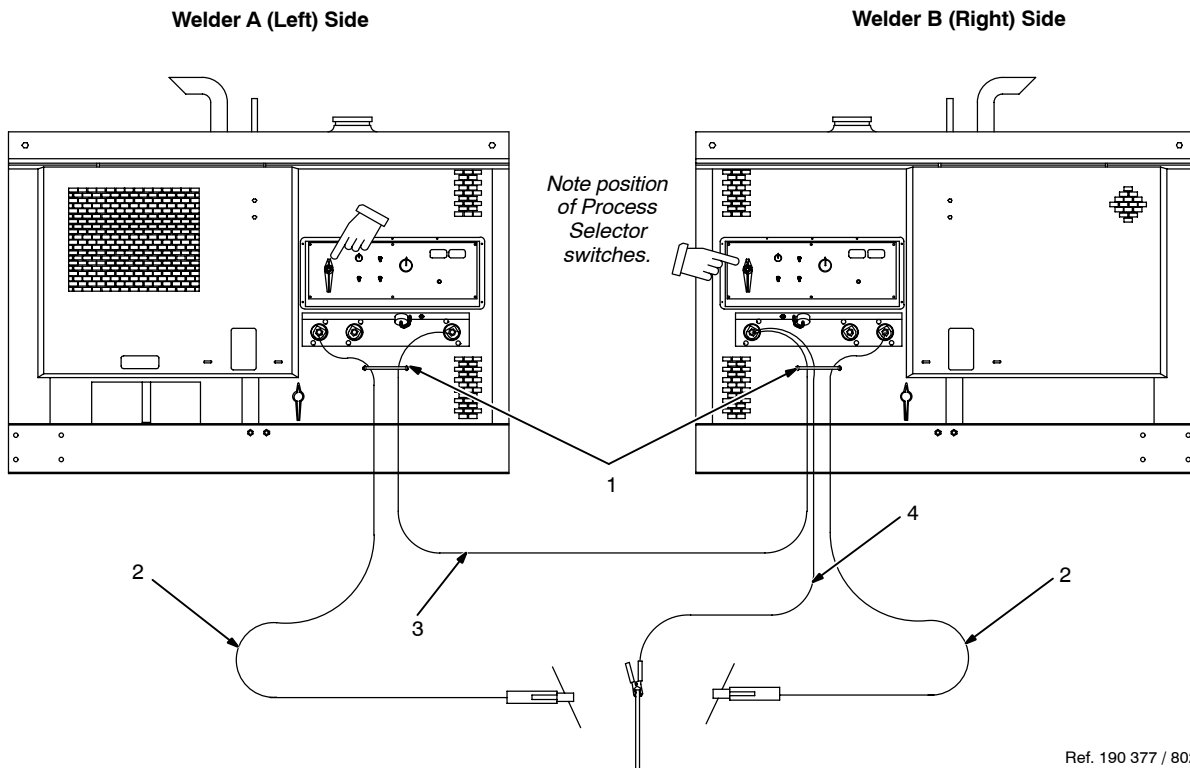

Ref. 190 377 / 802 292-A

### ▲ Stop engine.

### ▲ Do not exceed machine duty cycle.

 For common work connection, work cable must be able to carry combined weld output of both CC weld output terminals (see Section 5-15 for proper cable size).

 Use Dual Operator mode for CC and CV welding (see Section 6-1).

1 Strain Relief

Route cables through strain reliefs.

2 Electrode Holder Cables

3 Work Jumper Cable

4 Common Work Cable

For Stick/TIG welding Direct Current Electrode Positive (DCEP), connect common work cable and work jumper cable to Welder B (right) Negative (-) terminal. Connect other end of work jumper cable to Welder A (left) Negative (-) terminal.

Connect electrode holder cables to CC terminals.

For Stick/TIG Direct Current Electrode Negative (DCEN), connect common work cable and work jumper cable to Welder B (right) CC terminal. Connect other end of

work jumper cable to Welder A (left) CC terminal.





Connect electrode holder cables to Negative (-) terminals.

If unit has the Polarity switch option, connect common work cable and work jumper cable to Welder B (right) Work receptacle. Connect other end of work jumper cable to Welder A (left) Work receptacle.

Connect electrode holder cables to Electrode receptacles.

 Be sure Process Selector switches and optional Polarity switches are set correctly. See Section 6-3.

## 5-10. Making Dual Operator CV Weld Connections w/ Separate Work Cables



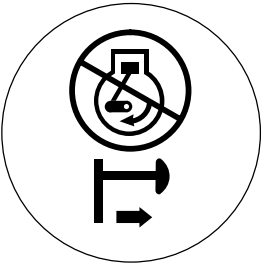
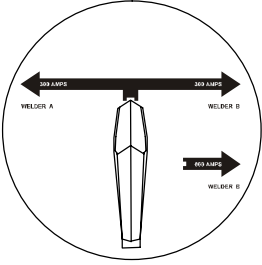

Tools Needed:

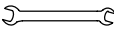
 3/4 in

 *Direct Current Electrode Positive (DCEP) connections are shown.*

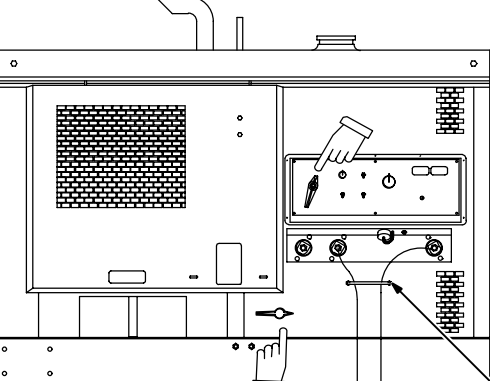
**Welder A (Left Side)**



*Note position of optional Polarity switch.*

**Welder B (Right Side)**

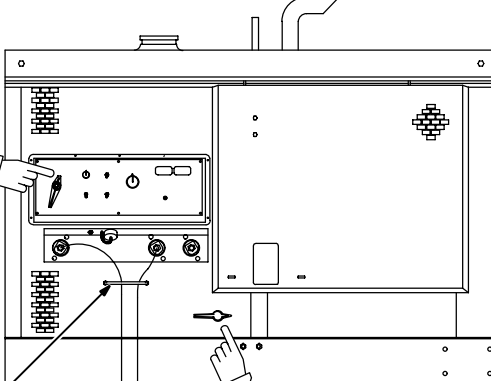

*Note position of optional Polarity switch.*

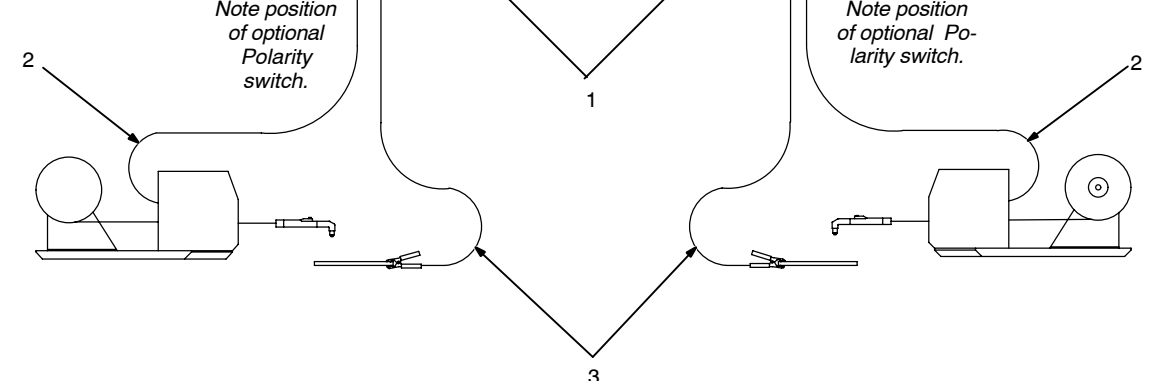

**▲ Stop engine.**

**▲ Do not exceed machine duty cycle.**

 Use Dual Operator mode for CC and CV welding (see Section 6-1).

See Section 5-15 for proper cable size.

1 Strain Reliefs  
Route cables through strain reliefs.

2 Wire Feeder Cables

3 Work Cables

For MIG and FCAW welding Direct Current Electrode Positive (DCEP), connect work cables to Negative (-) terminals and wire feeder cables to CV terminals.

For MIG and FCAW Direct Current Electrode Negative (DCEN), connect work cables to CV terminals and wire feeder cables to Negative (-) terminals.

Ref. 190 377 / 802 292-A

If unit has the Polarity switch option, connect work cables to Work receptacles and wire feeder cables to CV receptacles.

 Place optional Polarity switches in Reverse position when using CV weld receptacles. There is no CV weld output when switch is in Straight position.

 Be sure Process Selector and Polarity switches are set correctly. See Section 6-3.



## 5-11. Making Dual Operator CV Weld Connections w/ Common Work Cable

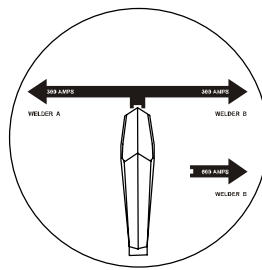
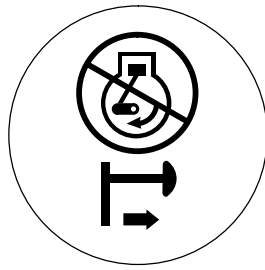

Tools Needed:

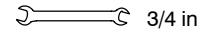

### ▲ INADEQUATE CABLE CONNECTIONS can cause serious damage to welding generator and create a hazardous condition.

When making weld connections with a common work cable, connect a weld cable of adequate size between the Negative (-) weld terminals, and connect a single weld cable of adequate size from the Welder B (right) Negative (-) terminal to the workpiece.

When using these connections as a common work terminal, all connections must be of the same polarity.

For a common work cable connection, the work cable must be able to carry the combined weld output of both modules (see Section 5-15 for proper cable size).

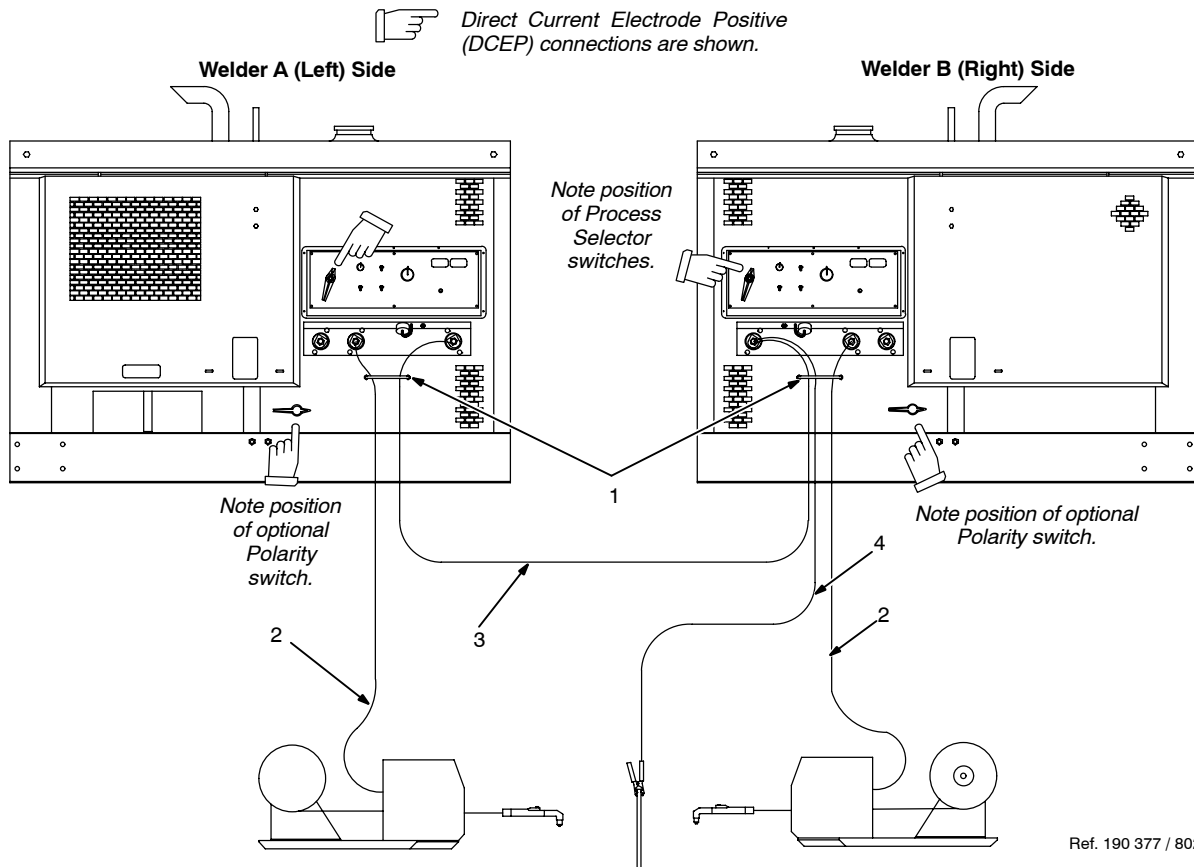

### ▲ Stop engine.

### ▲ Do not exceed machine duty cycle.

☞ For common work connection, work cable must be able to carry combined weld output of both CC weld output terminals (see Section 5-15 for proper cable size).

☞ Use Dual Operator mode for CC and CV welding (see Section 6-1).

#### 1 Strain Relief

Route cables through strain reliefs.

#### 2 Wire Feeder Cables

#### 3 Work Jumper Cable

#### 4 Common Work Cable

For MIG and FCAW welding Direct Current Electrode Positive (DCEP), connect common work cable and work jumper cable to Welder B (right) Negative (-) terminal. Connect other end of work jumper cable to Welder A (left) Negative (-) terminal.

Connect wire feeder cables to CV terminals.

For MIG and FCAW Direct Current Electrode Negative (DCEN), connect common work cable and work jumper cable to Welder B (right) CV terminal. Connect other end of work jumper cable to Welder A (left) CV terminal.

Connect wire feeder cables to Negative (-) terminals.

If unit has the Polarity switch option, connect common work cable and work jumper cable to Welder B (right) Work receptacle. Connect other end of work jumper cable to Welder A (left) Work receptacle.

Connect wire feeder cables to CV receptacles.

☞ Place optional Polarity switches in Reverse position when using CV weld receptacles. There is no CV weld output when switch is in Straight position.

☞ Be sure Process Selector and Polarity switches are set correctly. See Section 6-3.

## 5-12. Making Dual Operator CC And CV Weld Connections w/ Separate Work Cables

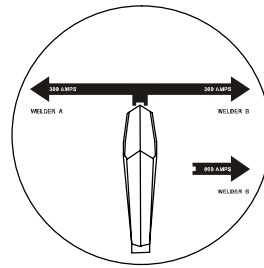
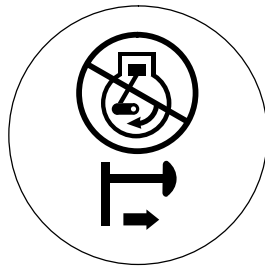

Tools Needed:

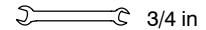

3/4 in

 Direct Current Electrode Positive (DCEP) connections are shown.

Welder A (Left Side)

Welder B (Right Side)

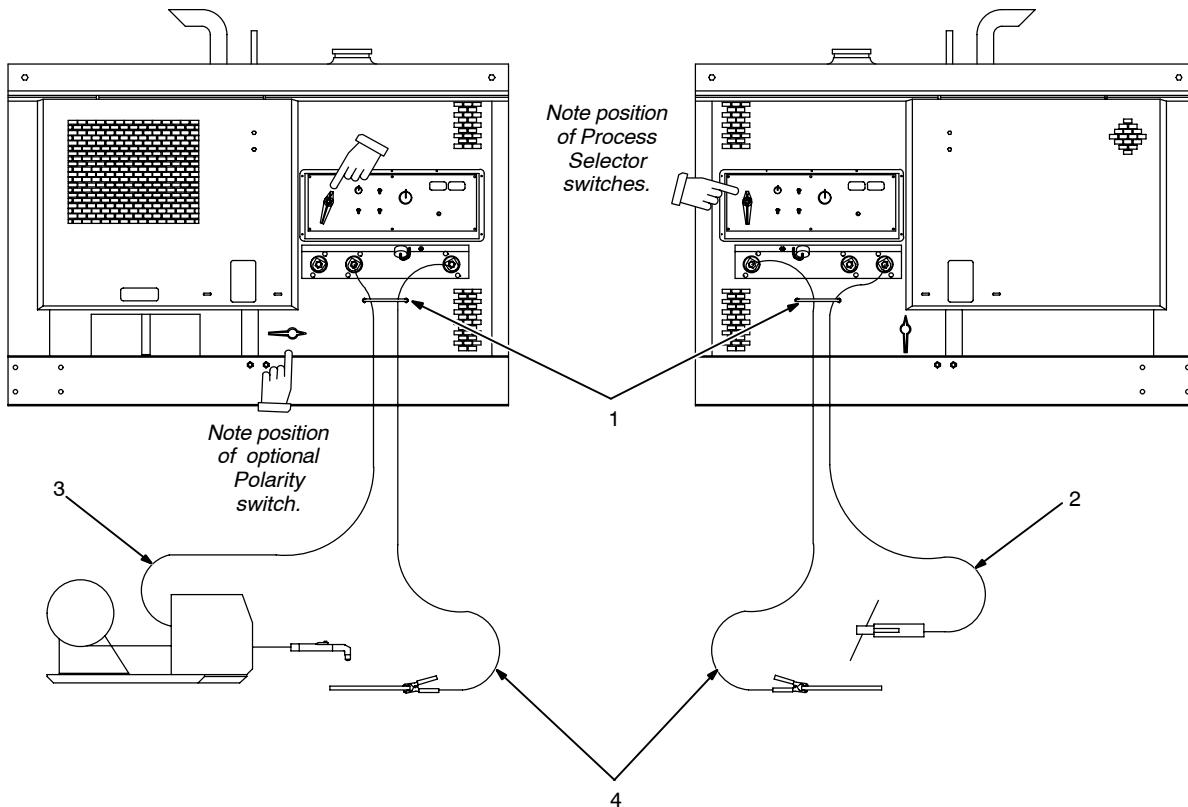

Ref. 190 377 / 802 292-A

▲ **Stop engine.**

▲ **Do not exceed machine duty cycle.**

 Use Dual Operator mode for CC and CV welding (see Section 6-1).

See Section 5-15 for proper cable size.

1 Strain Reliefs

Route cables through strain reliefs.

2 Electrode Holder Cable

3 Wire Feeder Cable

4 Work Cables

For Stick/TIG welding Direct Current Electrode Positive (DCEP), connect work cable

to Negative (-) terminal and electrode holder cable to CC terminal.

For Stick/TIG Direct Current Electrode Negative (DCEN), connect work cable to CC terminal and electrode holder cable to Negative (-) terminal.

 Be sure Process Selector switches are set correctly. See Section 6-3.

For MIG and FCAW welding Direct Current Electrode Positive (DCEP), connect work cable to Negative (-) terminal and wire feeder cable to CV terminal.

For MIG and FCAW Direct Current Electrode Negative (DCEN), connect work cable to CV terminal and wire feeder cable to Negative (-) terminal.

For Stick/TIG welding on units with Polarity switch option, connect work cable to Work receptacle and electrode cable to Electrode receptacle.

For MIG/FCAW welding on units with Polarity switch option, connect work cable to Work receptacle and wire feeder cable to CV receptacle.

 Place optional Polarity switches in Reverse position when using CV weld receptacles. There is no CV weld output when switch is in Straight position.

 Be sure Process Selector and Polarity switches are set correctly. See Section 6-3.

## 5-13. Making Dual Operator CC And CV Weld Connections w/ Common Work Cable

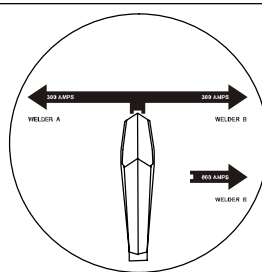
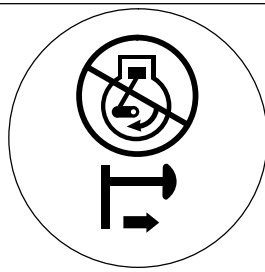

Tools Needed:

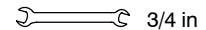

### ▲ INADEQUATE CABLE CONNECTIONS can cause serious damage to welding generator and create a hazardous condition.

When making weld connections with a common work cable, connect a weld cable of adequate size between the Negative (-) weld terminals, and connect a single weld cable of adequate size from the Welder B (right) Negative (-) terminal to the workpiece.

When using these connections as a common work terminal, all connections must be of the same polarity.

For a common work cable connection, the work cable must be able to carry the combined weld output of both modules (see Section 5-15 for proper cable size).

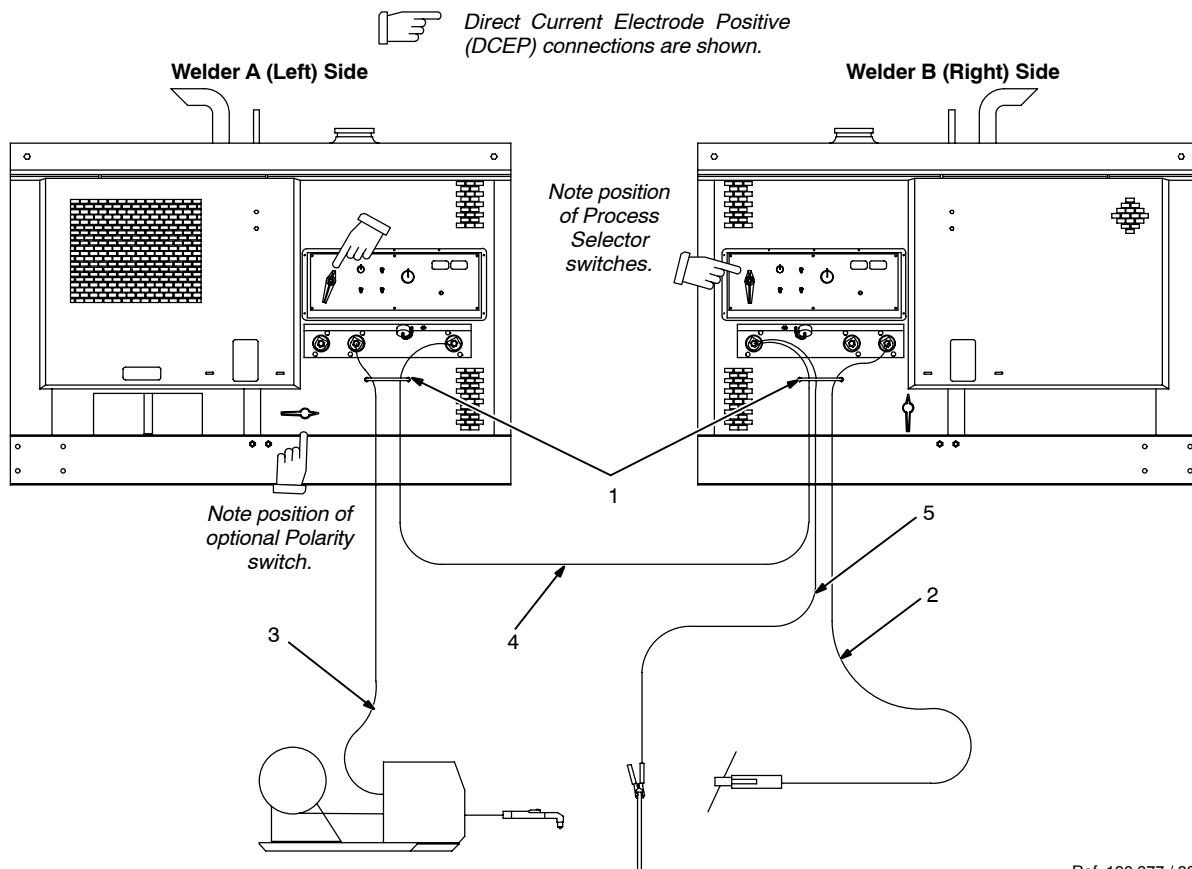

Ref. 190 377 / 802 292-A

### ▲ Stop engine.

### ▲ Do not exceed machine duty cycle.

☞ For common work connection, work cable must be able to carry combined weld output of both CC weld output terminals (see Section 5-15 for proper cable size).

☞ Use Dual Operator mode for CC and CV welding (see Section 6-1).

#### 1 Strain Reliefs

Route cables through strain reliefs.

#### 2 Electrode Holder Cable

#### 3 Wire Feeder Cable

#### 4 Work Jumper Cable

#### 5 Common Work Cable

For Direct Current Electrode Positive (DCEP), connect common work cable and work jumper cable to Welder B (right) Negative (-) terminal. Connect other end of work jumper cable to Welder A (left) Negative (-) terminal.

Connect electrode holder cable to either CC terminal.

Connect wire feeder cable to CV terminal on other side.

☞ Be sure Process Selector switches are set correctly. See Section 6-3.

For Direct Current Electrode Negative (DCEN), connect common work cable and work jumper cable to Welder B (right) CC terminal. Connect other end of work jumper cable to Welder A (left) CV terminal.

Connect electrode holder cable to either Negative (-) terminal, and wire feeder cable to remaining Negative (-) terminal.

If unit has the Polarity switch option, connect common work cable and work jumper cable to Welder B (right) Work receptacle. Connect other end of work jumper cable to Welder A (left) Work receptacle.

Connect electrode holder cable to either Electrode receptacle.

Connect wire feeder cable to CV receptacle on other side.

☞ Place optional Polarity switch in Reverse position when using CV weld receptacle. There is no CV weld output when switch is in Straight position.

☞ Be sure Process Selector and Polarity switches are set correctly. See Section 6-3.

## 5-14. Making Single Operator CC Weld Connections

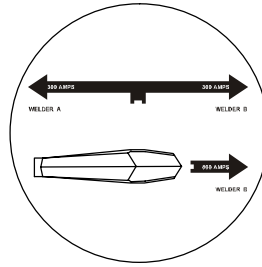
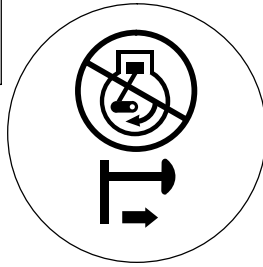

Direct Current Electrode Positive (DCEP) connections are shown.

**Welder A (left) Terminals Inactive In Single Operator Mode**

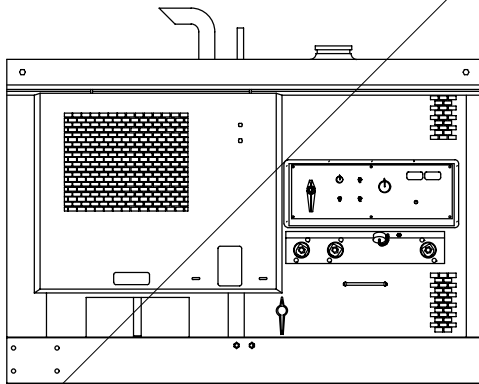

**Welder B(Right) Side**

Note position of Process Selector switch.

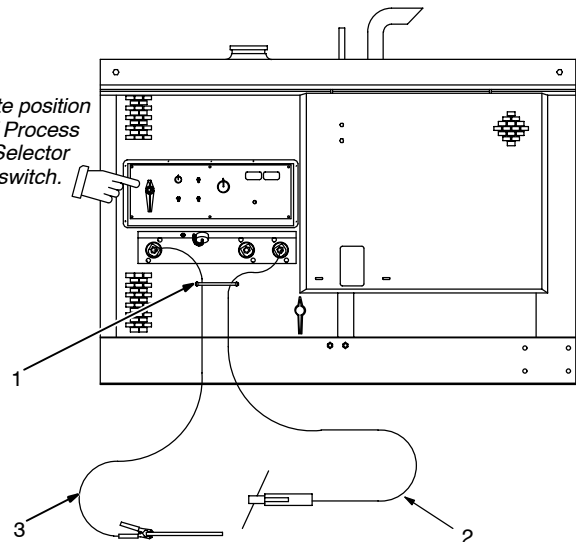

Tools Needed:

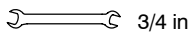

190 377 / 802 292-A

▲ **Stop engine.**

▲ **Do not exceed machine duty cycle.**

☞ *Welder A (left) weld output terminals are disabled in Single Operator mode. Connect only to Welder B (right) terminals for Single Operator mode operation.*

☞ *Use Single Operator mode for CC welding only. Welder A and Welder B CV weld output terminals are disabled in*

*Single Operator mode. (see Section 5-8).*

☞ *See Section 5-15 for proper cable size.*

See Section 5-15 for proper cable size.

- 1 Strain Relief
- Route cables through strain reliefs.
- 2 Electrode Holder Cable
- 3 Work Cable

For Stick/TIG welding Direct Current Electrode Positive (DCEP), connect work cable

to Negative (-) terminal and electrode holder cable to CC terminal.

For Stick/TIG Direct Current Electrode Negative (DCEN), connect work cable to CC terminal and electrode holder cable to Negative (-) receptacle.

If unit has the Polarity switch option, connect work cable to Work terminal and electrode holder cable to Electrode receptacle.

☞ *Be sure Process Selector switch is set correctly. See Section 6-3.*

# Notes

## DECIMAL EQUIVALENTS

	$\frac{1}{64}$	.015625
	$\frac{1}{32}$	.03125
	$\frac{3}{64}$	.046875
$\frac{1}{16}$	$\frac{5}{64}$	.0625
	$\frac{7}{64}$	.078125
	$\frac{9}{32}$	.09375
$\frac{1}{8}$	$\frac{11}{64}$	.109375
	$\frac{13}{64}$	.125
	$\frac{15}{32}$	.140625
	$\frac{17}{64}$	.15625
$\frac{3}{16}$	$\frac{19}{64}$	.171875
	$\frac{21}{64}$	.1875
	$\frac{23}{32}$	.203125
	$\frac{25}{64}$	.21875
$\frac{1}{4}$	$\frac{27}{64}$	.234375
	$\frac{29}{64}$	.25
	$\frac{31}{32}$	.265625
	$\frac{33}{64}$	.28125
$\frac{5}{16}$	$\frac{35}{64}$	.296875
	$\frac{37}{64}$	.3125
	$\frac{39}{32}$	.328125
	$\frac{41}{64}$	.34375
$\frac{3}{8}$	$\frac{43}{64}$	.359375
	$\frac{45}{64}$	.375
	$\frac{47}{32}$	.390625
	$\frac{49}{64}$	.40625
$\frac{7}{16}$	$\frac{51}{64}$	.421875
	$\frac{53}{64}$	.4375
	$\frac{55}{32}$	.453125
	$\frac{57}{64}$	.46875
$\frac{1}{2}$	$\frac{59}{64}$	.484375
	$\frac{61}{64}$	.5
	$\frac{63}{32}$	.515625
	$\frac{65}{64}$	.53125
$\frac{9}{16}$	$\frac{67}{64}$	.546875
	$\frac{69}{64}$	.5625
	$\frac{71}{32}$	.578125
	$\frac{73}{64}$	.59375
$\frac{5}{8}$	$\frac{75}{64}$	.609375
	$\frac{77}{64}$	.625
	$\frac{79}{32}$	.640625
	$\frac{81}{64}$	.65625
$\frac{11}{16}$	$\frac{83}{64}$	.671875
	$\frac{85}{64}$	.6875
	$\frac{87}{32}$	.703125
	$\frac{89}{64}$	.71875
$\frac{3}{4}$	$\frac{91}{64}$	.734375
	$\frac{93}{64}$	.75
	$\frac{95}{32}$	.765625
	$\frac{97}{64}$	.78125
$\frac{13}{16}$	$\frac{99}{64}$	.796875
	$\frac{101}{64}$	.8125
	$\frac{103}{32}$	.828125
	$\frac{105}{64}$	.84375
$\frac{7}{8}$	$\frac{107}{64}$	.859375
	$\frac{109}{64}$	.875
	$\frac{111}{32}$	.890625
	$\frac{113}{64}$	.90625
$\frac{15}{16}$	$\frac{115}{64}$	.921875
	$\frac{117}{64}$	.9375
	$\frac{119}{32}$	.953125
	$\frac{121}{64}$	.96875
$\frac{1}{1}$	$\frac{123}{64}$	.984375
	$\frac{125}{64}$	1.

## 5-15. Selecting Weld Cable Sizes\*

 <p><b>Weld Output Terminals</b></p> <p>▲ Turn off power before connecting to weld output terminals.</p> <p>▲ Do not use worn, damaged, undersized, or poorly spliced cables.</p>	Welding Amperes	Weld Cable Size** and Total Cable (Copper) Length in Weld Circuit Not Exceeding***							
		100 ft (30 m) or Less		150 ft (45 m)	200 ft (60 m)	250 ft (70 m)	300 ft (90 m)	350 ft (105 m)	400 ft (120 m)
		10 – 60% Duty Cycle	60 – 100% Duty Cycle	10 – 100% Duty Cycle					
	100	4 (20)	4 (20)	4 (20)	3 (30)	2 (35)	1 (50)	1/0 (60)	1/0 (60)
	150	3 (30)	3 (30)	2 (35)	1 (50)	1/0 (60)	2/0 (70)	3/0 (95)	3/0 (95)
	200	3 (30)	2 (35)	1 (50)	1/0 (60)	2/0 (70)	3/0 (95)	4/0 (120)	4/0 (120)
	250	2 (35)	1 (50)	1/0 (60)	2/0 (70)	3/0 (95)	4/0 (120)	2 ea. 2/0 (2x70)	2 ea. 2/0 (2x70)
	300	1 (50)	1/0 (60)	2/0 (70)	3/0 (95)	4/0 (120)	2 ea. 2/0 (2x70)	2 ea. 3/0 (2x95)	2 ea. 3/0 (2x95)
	350	1/0 (60)	2/0 (70)	3/0 (95)	4/0 (120)	2 ea. 2/0 (2x70)	2 ea. 3/0 (2x95)	2 ea. 3/0 (2x95)	2 ea. 4/0 (2x120)
	400	1/0 (60)	2/0 (70)	3/0 (95)	4/0 (120)	2 ea. 2/0 (2x70)	2 ea. 3/0 (2x95)	2 ea. 4/0 (2x120)	2 ea. 4/0 (2x120)
	500	2/0 (70)	3/0 (95)	4/0 (120)	2 ea. 2/0 (2x70)	2 ea. 3/0 (2x95)	2 ea. 4/0 (2x120)	3 ea. 3/0 (3x95)	3 ea. 3/0 (3x95)
	600	3/0 (95)	4/0 (120)	2 ea. 2/0 (2x70)	2 ea. 3/0 (2x95)	2 ea. 4/0 (2x120)	3 ea. 3/0 (3x95)	3 ea. 4/0 (3x120)	3 ea. 4/0 (3x120)
	700	4/0 (120)	2 ea. 2/0 (2x70)	2 ea. 3/0 (2x95)	2 ea. 4/0 (2x120)	3 ea. 3/0 (3x95)	3 ea. 4/0 (3x120)	3 ea. 4/0 (3x120)	4 ea. 4/0 (4x120)
	800	4/0 (120)	2 ea. 2/0 (2x70)	2 ea. 3/0 (2x95)	2 ea. 4/0 (2x120)	3 ea. 4/0 (3x120)	3 ea. 4/0 (3x120)	4 ea. 4/0 (4x120)	4 ea. 4/0 (4x120)

\* This chart is a general guideline and may not suit all applications. If cables overheat, use next size larger cable.

\*\*Weld cable size (AWG) is based on either a 4 volts or less drop or a current density of at least 300 circular mils per ampere.  
( ) = mm<sup>2</sup> for metric use

\*\*\*For distances longer than those shown in this guide, call a factory applications representative at 920-735-4505.

S-0007-F

## 5-16. Installing Ether Cylinder (Optional Ether Starting Aid)

**▲ Stop engine.**

**▲ Improper handling or exposure to ether can harm your health. Follow manufacturer's safety instructions on cylinder.**

**▲ Do not use Ether Starting Aid while engine is running.**

Open right side door.

1 Ether Cylinder  
2 Nozzle

Remove cover and clean cylinder nozzle.

3 Clamp  
4 Fitting  
5 Cap  
6 Valve

Remove cap and clean fitting. Install cylinder on fitting. Tighten clamp.

After installing cylinder, wait at least 10 minutes before using to let ether particles settle and prevent atomizer plugging.

Put cap on fitting when cylinder is removed.

ether1 7/96 - 153 382-A / 190 377 / 802 291-A

## 5-17. Remote 14 Receptacle Information

### NOTE

Place Welder Selector switch in Welder A/Welder B position (dual operator mode) for both remote receptacles to work. Welder A (left) remote receptacle output contactor and control is disabled when switch is in Welder B position.

REMOTE 14	Socket*	Socket Information
24 VOLTS AC OUTPUT (CONTACTOR)	A	24 volts ac. Protected by circuit breakers CB5 and CB6.
	B	Contact closure to A completes 24 volts ac contactor control circuit.
REMOTE OUTPUT CONTROL	C	Output to remote control; +10 volts dc in CV, 0 to +10 volts dc in CC.
	D	Remote control circuit common.
	E	0 to +10 volts dc input command signal from remote control.
A/V AMPERAGE VOLTAGE	F	Current feedback; 0 to +10 volts dc, 1 volt per 100 amperes.
	H	Voltage feedback; +1 volts dc per 10 arc volts.
115 VOLTS AC OUTPUT (CONTACTOR)	I	115 volts, 15 amperes, 60 Hz ac. Protected by circuit breakers CB5 and CB6.
	J	Contact closure to I completes 115 volts ac contactor control circuit.
GND	K	Chassis common.
	G	Circuit common for 24 and 115 volts ac circuits.

\*The remaining sockets are not used.

# 5-18. Remote 14 Receptacle Connections

## Dual Operator Operation

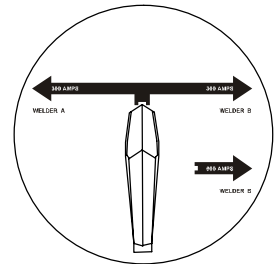
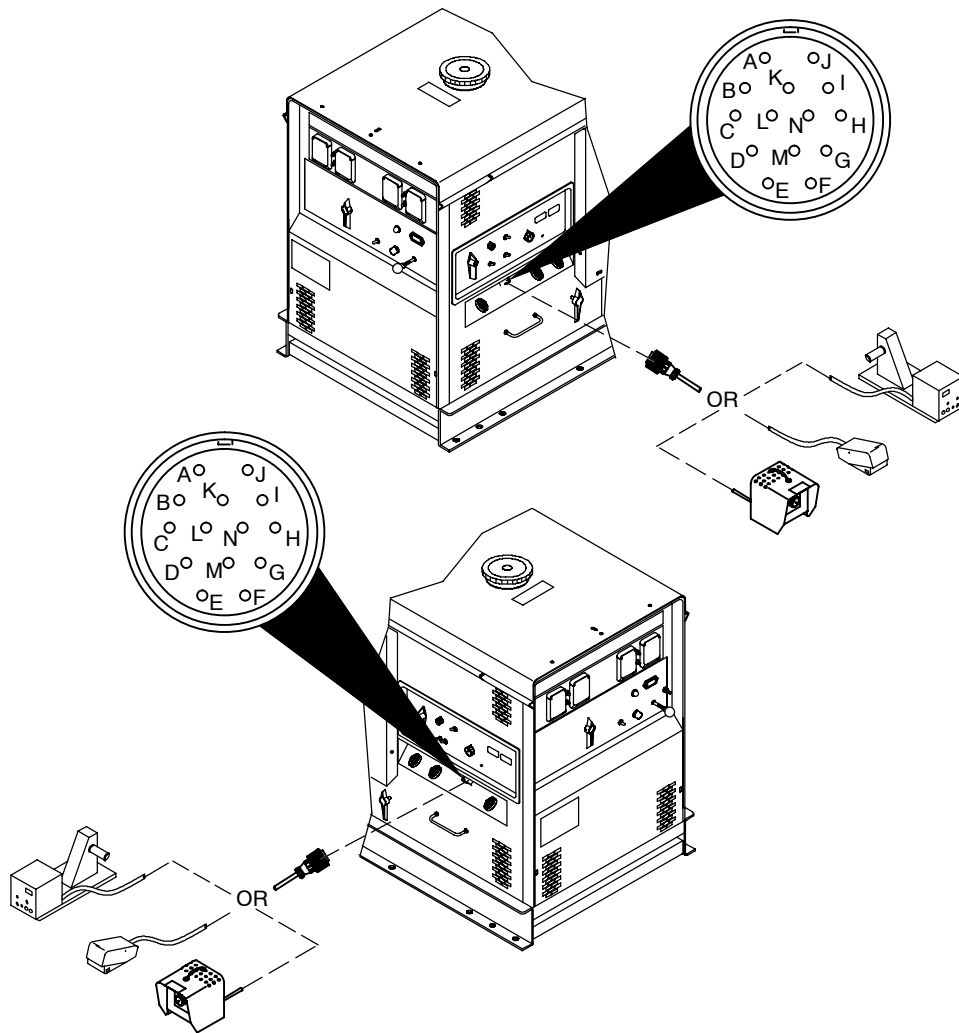

## Single Operator Operation

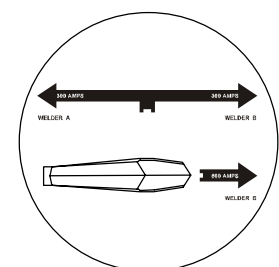
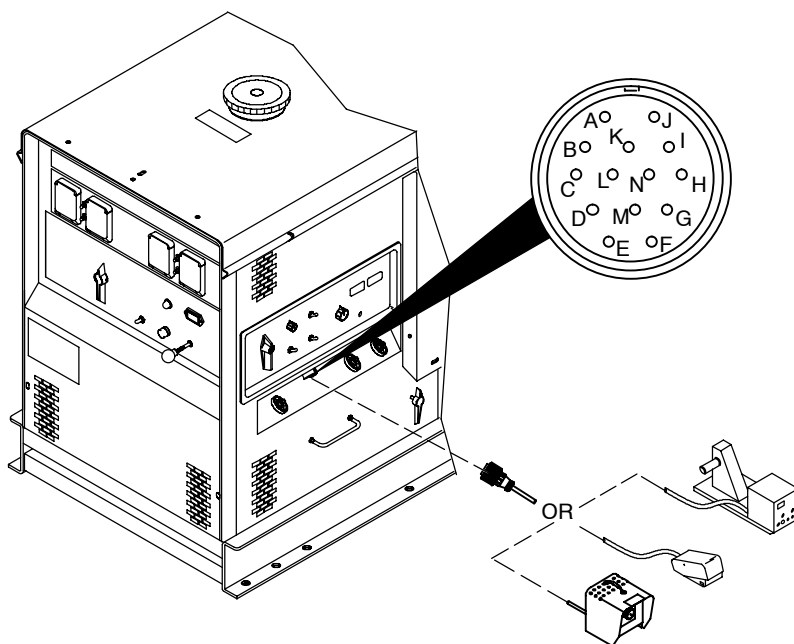

Ref. 802 291-A





## 6-2. Weld Controls (See Section 6-3)

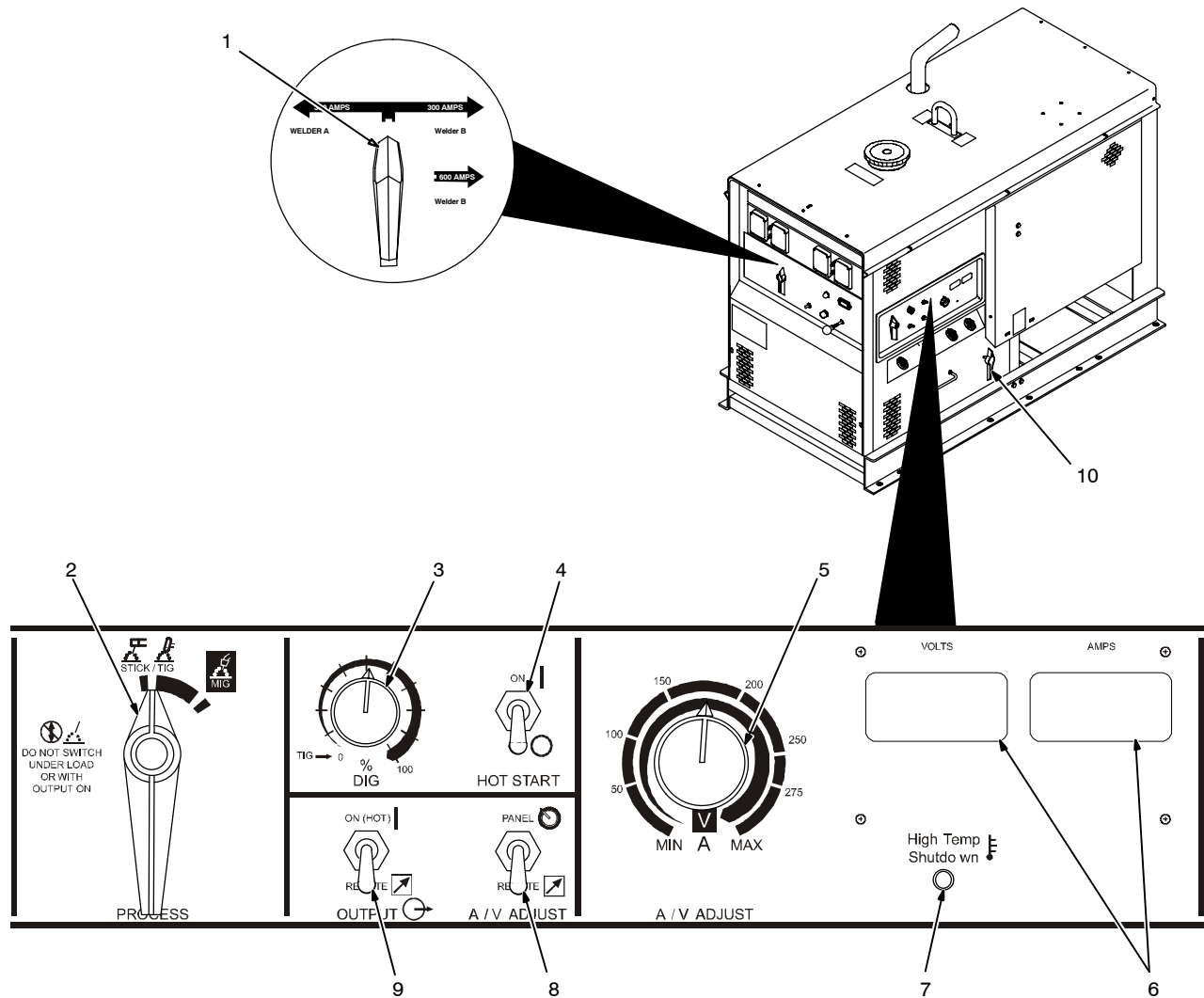

## 6-3. Weld Control Descriptions (See Section 6-2)





### 1 Welder Selector Switch

Use switch to select Dual Operator or Single Operator welding mode.

Place switch in Welder A/Welder B (dual operator) position for CC and CV output from Welder A (left) and Welder B (right) weld output terminals. Control the weld output from the terminals on each side using the weld controls on that same side.

Place switch in Welder B (single operator) position for CC weld output from Welder B (right) weld output terminals only. CV weld output terminals on both sides do not work when unit is in Single Operator mode.

 *Welder A (left) weld output terminals are disabled in Single Operator mode. Connect only to Welder B (right) terminals for Single Operator operation.*

 *When in single Operator mode, only CC weld output is available. Welder A (left) and Welder B (right) side CV weld output terminals are disabled in Single Operator mode. (see Section 5-8).*

### 2 Process Selector Switch

Use switch to select output for weld process. If switch is in Stick/Tig position, place Welder Selector switch in Welder A/Welder B or Welder B Position. If switch is in MIG position, place Welder Selector switch in Welder A/Welder B position only.

 *CV weld output for MIG is only available when Welder Selector switch is in Welder A/Welder B position. **All weld output stops if either Process Selector switch is placed in MIG position when Welder Selector switch is in Welder B position.***

 *Place optional Polarity switch in Reverse position when using CV weld output. There is no CV weld output when Polarity switch is in Straight position.*

 **Do not switch under load or with output on.**

### 3 Arc Force (Dig) Control

Use control to automatically increase amperage as arc length is decreased to assist in arc starts and reduce the chance of the electrode sticking in the puddle. Turn clockwise to increase short-circuit amperage. Set at minimum for TIG welding.

### 4 Hot Start Switch

Use switch to disable hot start circuit. Turn switch On for Stick (SMAW) and Submerged Arc (SAW) Welding, and Air Carbon Arc Cutting and Gouging (CAC-A). Turn switch Off for TIG (GTAW) welding.

When switch is in On position, higher short-circuit amperage helps arc starting. After arc starts, the front panel or remote Amperage/Voltage control setting determines weld amperage.

 *The hot start circuit does not function when constant voltage (CV) welding.*

### 5 Amperage/Voltage Control

When Process Selector switch is in the Stick/TIG position, turn control clockwise to increase amperage. Read amperage from outer scale of control. The Amperage/Voltage control adjusts amperage only when constant current (CC) welding and does not adjust open-circuit voltage.

When Process Selector switch is in the MIG position, turn control clockwise to increase voltage. Voltmeter value changes as control knob is turned. Control can be adjusted while welding.

 *When Welder Selector switch is in Welder B position (single operator mode), weld amperage is two times the value selected by the Amperage/Voltage control. For example, if Amperage/Voltage control is set to 250 A, weld output is actually 500A.*

### 6 Weld Meters

With Process Selector switch in the Stick/Tig position, meters read 0 (zero) with contactor off. Meters display actual output voltage and amperage with contactor on.

With Process Selector switch in the MIG position, voltmeter displays preset voltage with contactor off. Voltmeter and ammeter display actual output voltage and amperage with contactor on.

### 7 High Temperature Shutdown Light

Light goes on and weld output stops if weld rectifier gets too warm. Let unit cool before welding.

### 8 Remote Amperage/Voltage Control Switch

For front panel control, place switch in Panel position. For remote control, place switch in Remote position, and connect remote device (see Section 5-17).

### 9 Output (Contactor) Switch

For front panel control of output, place switch in On (Hot) position. For remote control of output, place switch in Remote position, and connect remote device (see Section 5-17).

 **Weld output terminals are energized when Output (Contactor) switch is On and engine is running.**

### 10 Polarity Switch (Optional)

 **Do not switch under load.**

Use switch to change polarity of weld output (see Sections 5-7 thru 5-14).

 *Place optional Polarity switch in Reverse position when using CV weld receptacle. There is no CV weld output when switch is in Straight position.*

# SECTION 7 – OPERATING AUXILIARY EQUIPMENT

## 7-1. 120 Volt And 240 Volt Duplex Receptacles

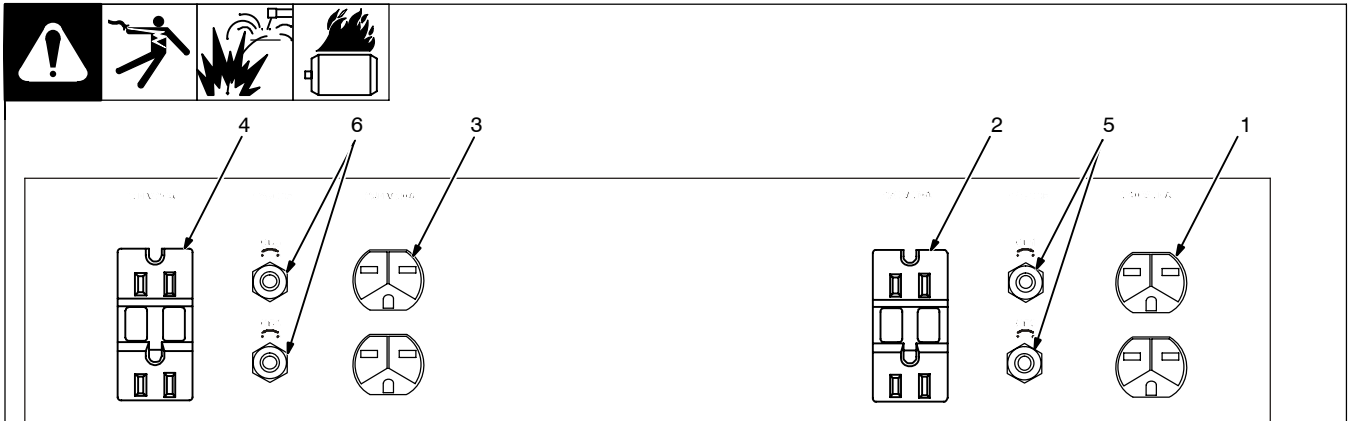

190 376

▲ **Be sure equipment connected to the 240 V receptacles is GFCI-protected.**

☞ *Generator power is not affected by position of Welder Selector switch.*

☞ *4 kVA/kW generator power output is shared by all receptacles.*

- 1 240 V 20 A AC Receptacle RC1
- 2 120 V 20 A AC GFCI Receptacle GFCI 1
- 3 240 V 20 A AC Receptacle RC2
- 4 120 V 20 A AC GFCI Receptacle GFCI 2

Receptacles supply 60 Hz single-phase power at weld/power speed.

If a ground fault is detected, the GFCI receptacle(s) circuit opens to disconnect the

faulty equipment and the GFCI Reset button pops out. Check for damaged tools, cords, plugs, etc. connected to the receptacle. Press button to reset receptacle and resume operation.

☞ *At least once a month, run engine at weld/power speed and press Test button to verify GFCI is working properly.*

- 5 Circuit Breakers CB1 And CB2
- 6 Circuit Breakers CB3 And CB4

CB1 and CB2 protect RC1 and GFCI 1 from overload. If CB1 or CB2 opens, RC1 does not work. 120 volts may still be present at RC1. If CB2 opens, GFCI 1 does not work. Press button to reset breaker.

CB3 and CB4 protect RC2 and GFCI 2 from overload. If CB3 or CB4 opens, RC2 does not work. 120 volts may still be present at

RC2. If CB4 opens, GFCI 2 does not work. Press button to reset breaker.

☞ *If a circuit breaker continues to open, contact Factory Authorized Service Agent.*

Maximum output from each 120 volt GFCI receptacle is 2.4 kVA/kW. Maximum output from each 240 volt duplex receptacle half is 4.0 kVA/kW.

Total combined output from all receptacles is 4 kVA/kW.

EXAMPLE: If 12 A is drawn from RC1, only 9 A is available at GFCI 1:

$$(240\text{ V} \times 12\text{ A}) + (120\text{ V} \times 9\text{ A}) = 4.0\text{ kVA/kW}$$

☞ *Generator power is not affected by weld output.*

# SECTION 8 – MAINTENANCE & TROUBLESHOOTING

## 8-1. Routine Maintenance

								<p>Recycle engine fluids.</p> <p><b>▲ Stop engine before maintaining.</b></p> <p> See Engine Manual and Maintenance Label for important start-up, service, and storage information. Service engine more often if used in severe conditions.</p>
--	--	--	--	--	--	--	--	---

		✓ = Check ◇ = Change ● = Clean ☆ = Replace * To be done by Factory Authorized Service Agent			Reference
Every 8 Hours	 <b>FUEL WATER</b>	 ✓ Fuel Level	 ✓ Oil Level	 ● Oil, Fuel Spills	Section 5-5, 8-4
Every 50 Hours	 ● Air Cleaner Element	 ● Weld Terminals			Section 8-3
Every 100 Hours	 ● Battery Terminals	 ✓ Air Cleaner Hoses	 ◇ Oil ◇ Oil Filter		
Every 250 Hours	 ☆ Unreadable Labels	 ✓ ● Spark Arrestor			Engine Manual, Section 8-9
Every 500 Hours	 ✓ ☆ Weld Cables				
Every 1000 Hours	 ✓ Fan Belt Tension   ✓ ● Slip Rings* ✓ ☆ Brushes*	 ● Inside Unit   ✓ Valve Clearance*	 ◇ Fuel Filter	 ● Drain Sludge	Section 8-4, 8-10 and Engine Manual



## 8-3. Servicing Air Cleaner

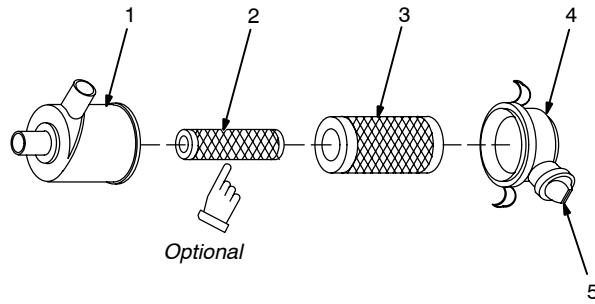
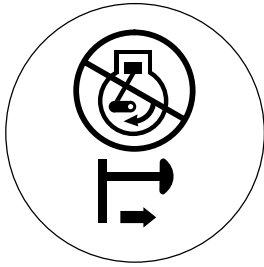

▲ **Stop engine.**

▲ **Do not run engine without air cleaner or with dirty element. Engine damage caused by using a damaged element is not covered by the warranty.**

☞ *The air cleaner primary element can be cleaned but the dirt holding capacity of the filter is reduced with each cleaning. The chance of dirt reaching the clean side of the filter while cleaning and the possibility of filter damage makes cleaning a risk. Consider the risk of unwarrantable equipment damage when determining whether to clean or replace the primary element.*

*If you decide to clean the primary element, we strongly recommend installing an optional safety element to provide additional engine protection. **Never clean a safety element.** Replace the safety element after servicing the primary element three times.*

Clean or replace primary element if dirty (see note above before cleaning). **Replace** primary element if damaged. Replace primary element yearly or after six cleanings.

- 1 Housing
- 2 Safety Element (Optional)
- 3 Primary Element
- 4 Dust Cap
- 5 Dust Ejector

**To clean air filter:**

Wipe off cap and housing. Remove cap and dump out dust. Remove element(s). Wipe dust from inside cap and housing with damp cloth. Reinstall safety element (if present). Reinstall cap.

▲ **Do not clean housing with air hose.**

Clean primary element with compressed air only.

Air pressure must not exceed 100 psi (690 kPa). Use 1/8 in (3 mm) nozzle and keep nozzle at least 2 in (51 mm) from inside of element. Replace primary element if it has holes or damaged gaskets.

Reinstall primary element and cap (dust ejector down).

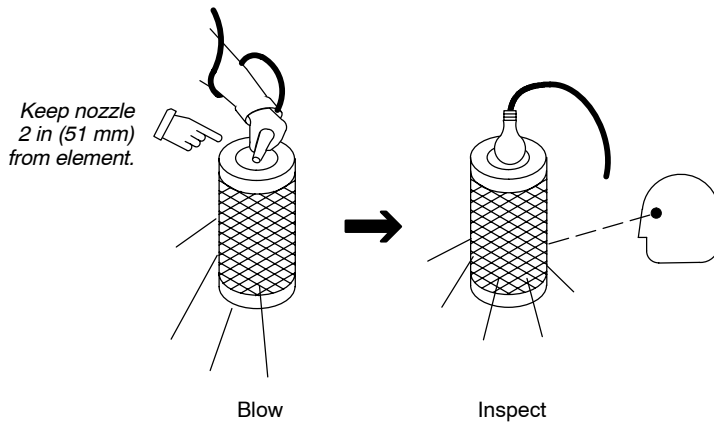

## 8-4. Servicing Fuel And Lubrication Systems

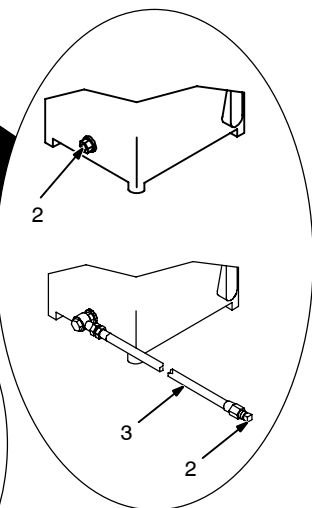
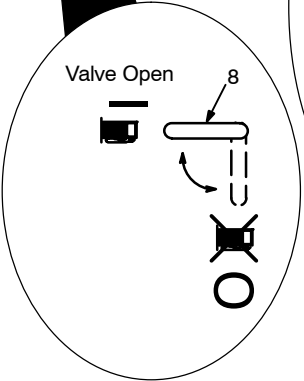
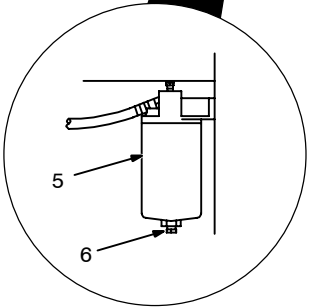
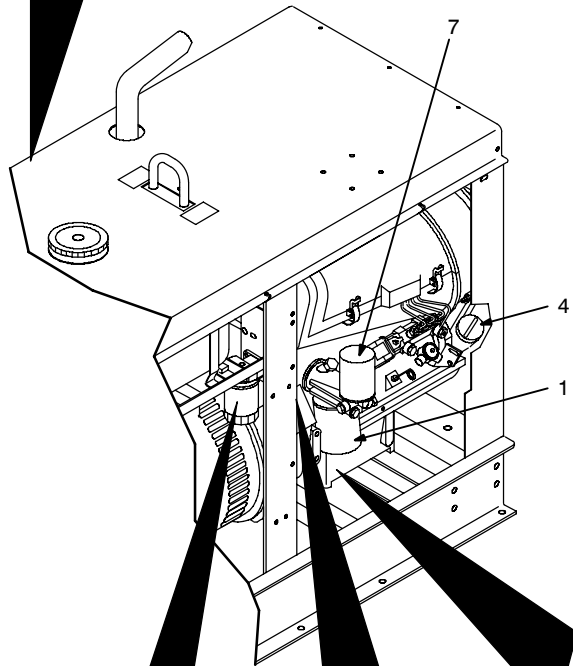
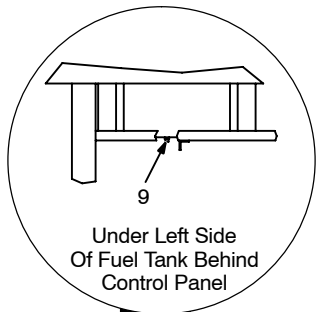
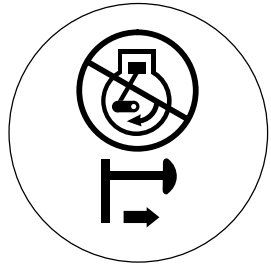

**▲ Stop engine and let cool.**

- 1 Oil Filter
- 2 Oil Drain Plug
- 3 Oil Drain Hose (Optional)
- 4 Oil Fill Cap
- 5 Primary Fuel Filter (Fuel/Water Separator)
- 6 Petcock
- 7 Secondary Fuel Filter
- 8 Fuel Shutoff Valve Lever
- 9 Sludge Drain Plug

**To change oil and filter:**

See engine manual.

**To drain water from fuel system:**

Open primary fuel filter petcock and drain water into metal container. Close petcock when water-free fuel flows.

**To replace primary fuel filter:**

Close shutoff valve and turn filter counterclockwise. Remove filter.

Apply thin coat of fuel to gasket on new filter. Install new filter and turn clockwise. Open shutoff valve. Bleed air from fuel system according to engine manual.

Inspect fuel line, and replace if cracked or worn.

**To replace secondary fuel filter:**

See engine manual.

**To drain sludge from fuel tank:**

This procedure should only be done by a Factory Authorized Service Agent.

Remove Welder A (left) control panel to access sludge drain plug.

Put metal container under drain and remove plug. Reinstall plug when sludge has drained.

Reinstall control panel.

**▲ After servicing, start engine and check for fuel leaks.**

**▲ Stop engine, tighten connections as necessary, and wipe up spilled fuel.**

Close doors.



**Tools Needed:**

3/8, 7/16, 3/4 in



## 8-5. Adjusting Engine Speed



Engine Speed (No Load)		RPM (HZ)
Weld/Power		1850 (61.6)

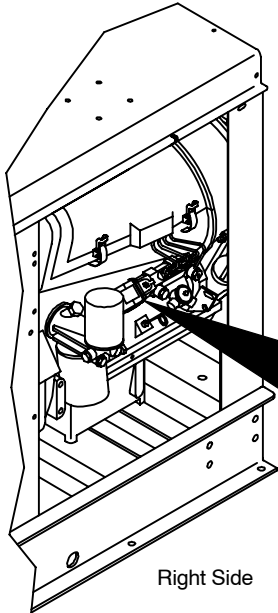

Right Side

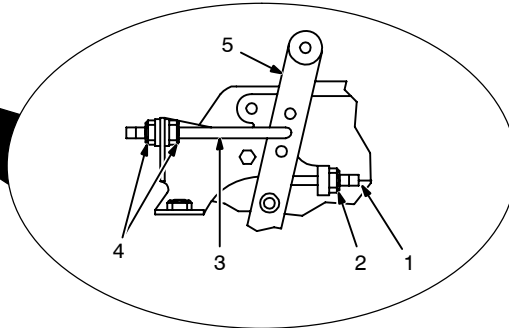

Tools Needed:

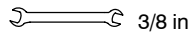

Engine speed is factory set and should not require adjustment. After tuning engine, check engine speed with tachometer. See table for proper no load speed. If necessary, adjust speed as follows:

- 1 High Speed Stop Screw
- 2 Lock Nut

Loosen nut. Turn screw out (toward front of engine) several turns.

- 3 Linkage
- 4 Lock Nuts

Loosen nuts. Start engine and move linkage until engine runs at weld/power speed. Tighten nuts.

### ▲ Stop engine.

- 5 Speed Control Lever

Turn screw in until screw touches lever. Tighten lock nut on screw.

Close side door.

Ref. 045 768-B

## 8-6. Servicing Optional Ether Starting Aid

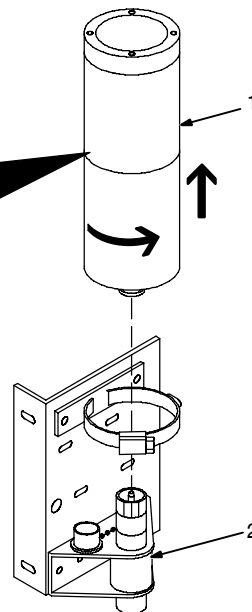
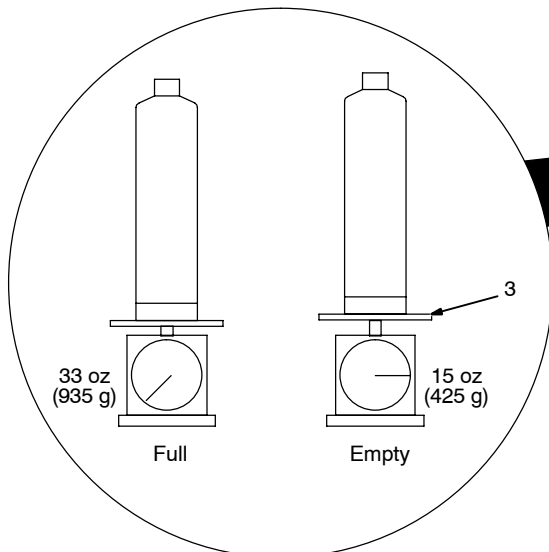
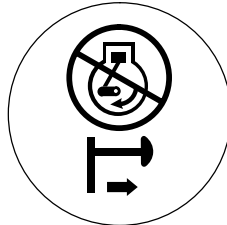

### ▲ Stop engine.

▲ Improper handling or exposure to ether can harm your health. Follow manufacturer's safety instructions on cylinder.

If engine does not start in cold weather, check ether cylinder as follows:

Remove cylinder from valve.

- 1 Ether Cylinder
- 2 Valve
- 3 Scale

Weigh cylinder to see if it is empty. Be sure atomizer is not plugged and valve fitting is clean.

Replace cylinder according to Section 5-16.

ether2 7/96 - 153 382-A / Ref. 190 377 / S-0692

## 8-7. Checking And Replacing Alternator Belt

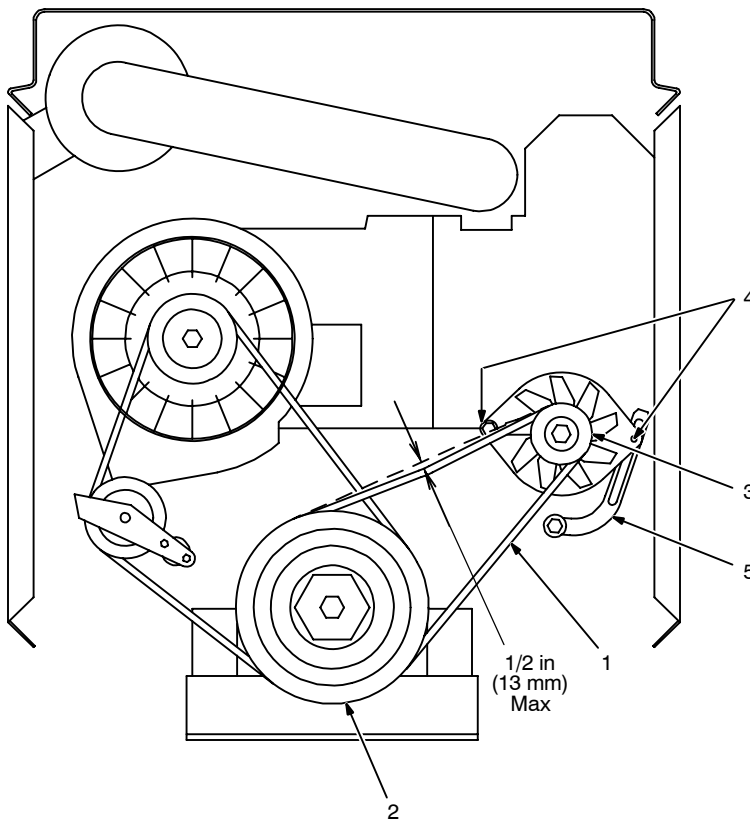
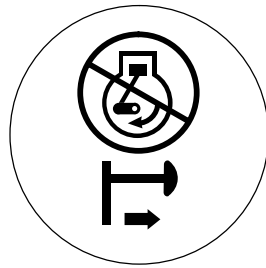

### ▲ Stop engine.

#### To check belt tension:

Remove rear panel.

- 1 Alternator V-Belt
- 2 Crank Pulley
- 3 Alternator Pulley

Place straight edge along top of pulleys. Pull down belt as far as it will go, then measure distance from belt to straight edge.

If measurement is less than 1/2 in (13 mm), belt is okay. If not okay, adjust belt tension.

#### To adjust belt tension:

- 4 Hex Nuts (2)
- 5 Alternator Bracket

Loosen nuts. Pivot alternator until belt is tight. Tighten nuts. Recheck tightness of belt. Readjust if necessary.

Replace belt if damaged or cracked.

#### To replace belt:

Loosen hex nuts and pivot alternator clockwise. Remove belt.

Install new belt, pivot alternator until belt is tight, and tighten nuts. Recheck tightness of belt after running engine 15 minutes.

Reinstall rear panel.

Tools Needed:

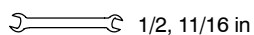

## 8-8. Resetting Fan Belt Safety Shutdown

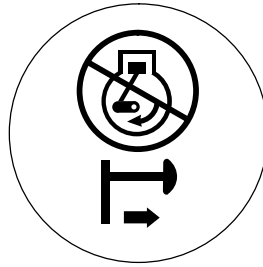

### ▲ Stop engine.

1 Cooling Fan V-Belt

See engine manual to replace or tighten belt.

If belt breaks or becomes loose, safety shutdown stops engine.

Correct problem, then reset safety shutdown as follows:

2 Rod

3 Stop

4 Bracket

5 Handle

Pull handle towards front of unit until stop snaps in position behind bracket.

Close door.

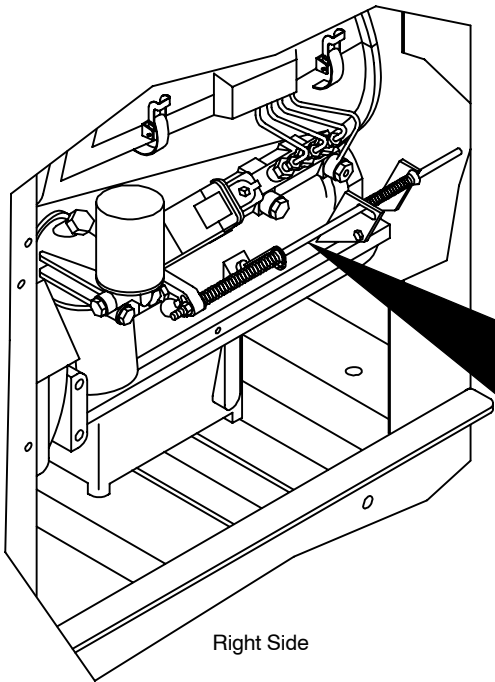
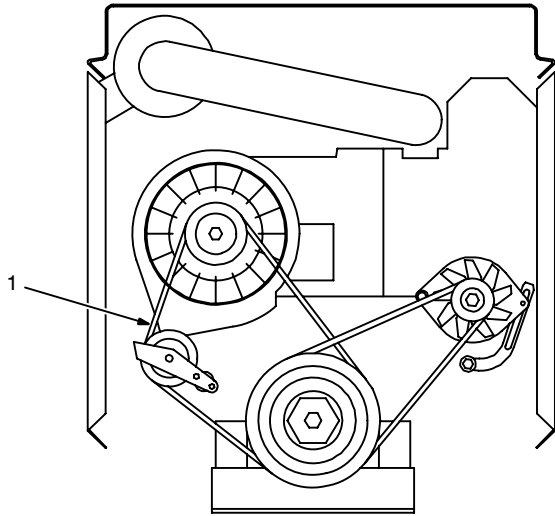

Right Side

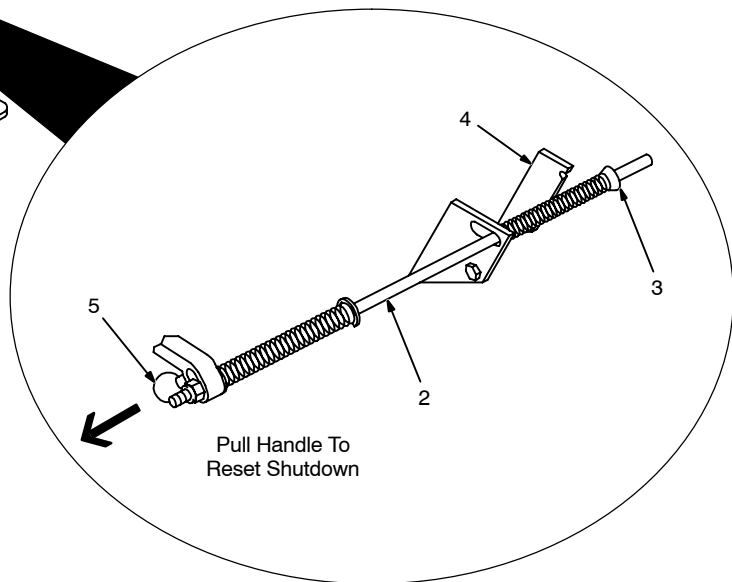

Tools Needed:

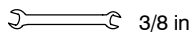
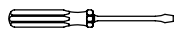

158 715 / Ref. 158 632 / Ref. 190 377

## 8-9. Inspecting And Cleaning Optional Spark Arrestor Muffler

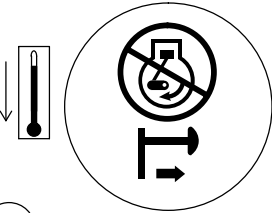
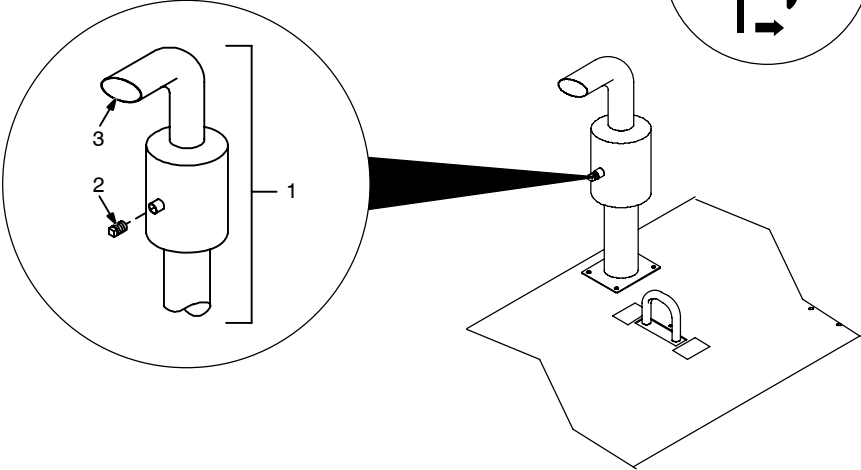
**▲ Stop engine and let cool.**

- 1 Spark Arrestor Muffler
- 2 Cleanout Plug
- 3 Exhaust Pipe

Remove plug and remove any dirt covering cleanout hole.

3 Exhaust Pipe

Start engine and run several minutes to blow out cleanout hole. If nothing blows out of hole, briefly cover end of exhaust pipe with fire-proof material.

**▲ Stop engine and let cool.**

Reinstall cleanout plug.

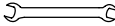
Tools Needed:  
 3/8 in

Ref. 800 633-B / Ref. 190 377

## 8-10. Checking Generator Brushes

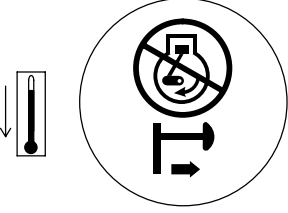
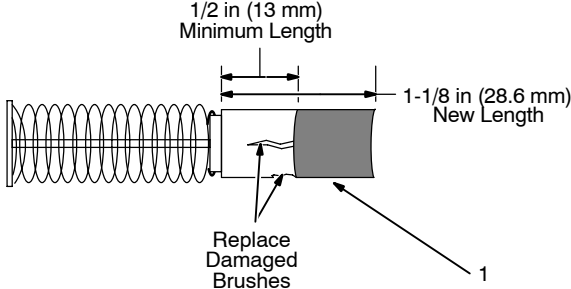
**▲ Stop engine and let cool.**

- 1 Generator Brush With Spring

Mark and disconnect leads at brush holder cap. Remove brushes.

Replace brushes if damaged or if brush material is at or near minimum length.

1/2 in (13 mm)  
Minimum Length

1-1/8 in (28.6 mm)  
New Length

Replace Damaged Brushes

1

Ref 217 359-A / S-0233-A

## 8-11. Circuit Protection

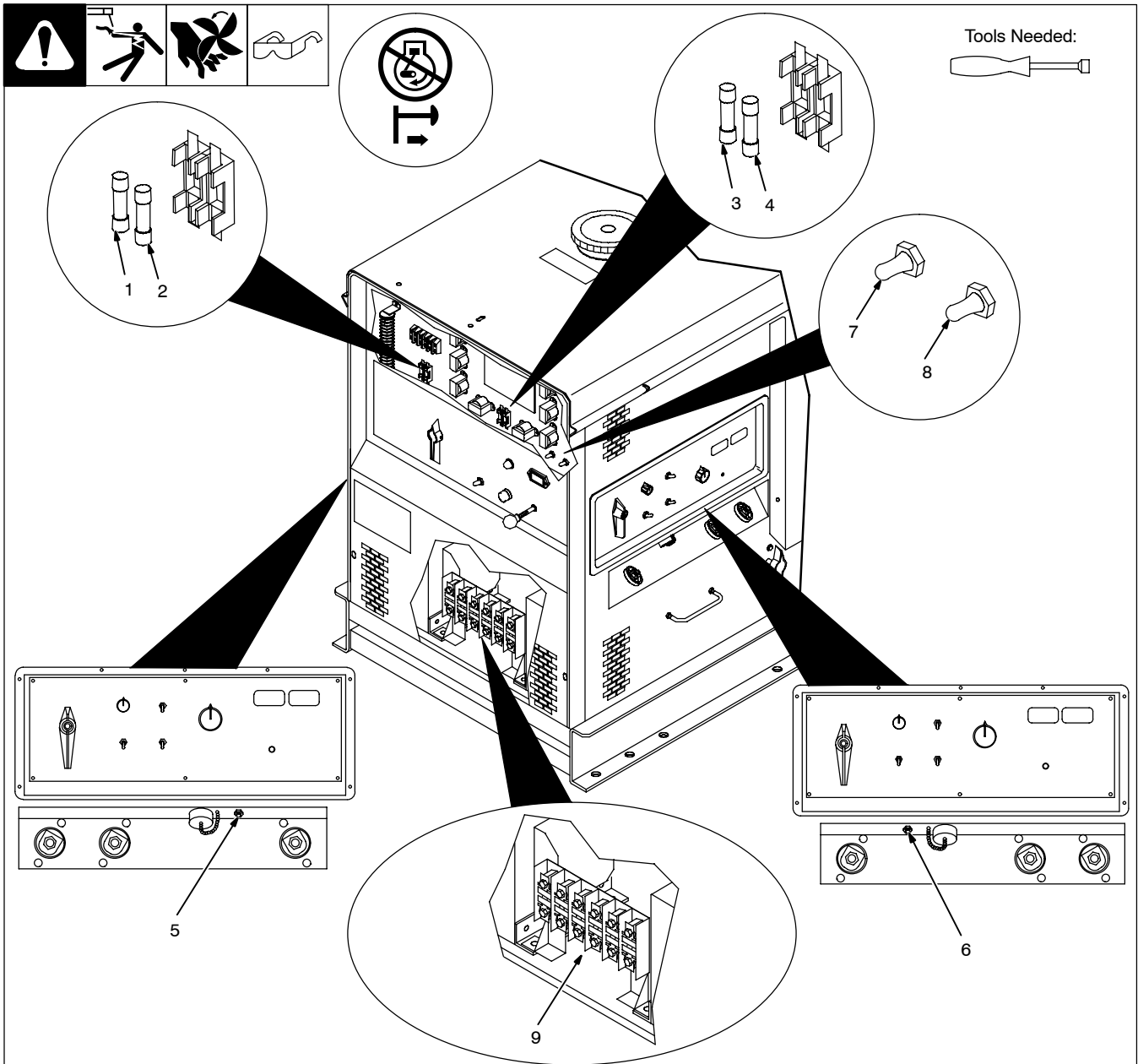

Ref. 802 300 / Ref. 802 292-A

### ▲ Stop engine.

☞ When a circuit breaker or fuse opens, it usually indicates a more serious problem exists. Contact Factory Authorized Service Agent.

- 1 Fuse F1
- 2 Fuse F2
- 3 Fuse F3
- 4 Fuse F4

Open front panel.

Fuse F1 protects the exciter excitation winding. If F1 opens, there is no weld or generator power output on both sides.

Fuse F2 protects the exciter main field excitation winding. If F2 opens, there is no weld output on both sides.

Fuse F3 protects Welder A (left) control board PC1. If F3 opens, Welder A (left) weld output stops.

Fuse F4 protects Welder B (right) control

board PC1. If F4 opens, Welder B (right) weld output stops.

- 5 Circuit Breaker CB5
- 6 Circuit Breaker CB6
- 7 Circuit Breaker CB7
- 8 Circuit Breaker CB8

Circuit Breaker CB5 protects the 24 volt and 115 volt ac output to Welder A (left) remote receptacle RC9. If CB5 opens, Welder A (left) RC9 24 and 115 volt ac output stops.

Circuit Breaker CB6 protects the 24 volt and 115 volt ac output to Welder B (right) remote receptacle RC8. If CB6 opens, Welder B (right) RC8 24 and 115 volt ac output stops.

Circuit Breaker CB7 protects field current regulator board PC4. If CB7 opens, weld and generator power output on both sides stops.

Circuit Breaker CB8 protects the generator field flashing circuit. If CB8 opens, weld and

generator power output may continue if generator maintains excitation. Weld and generator power output stops if generator requires field flashing circuit to restore excitation.

Press button to reset circuit breaker.

- 9 Fuses F11, F12, F13, F21, F22, F23

These fuses protect the weld stator windings. If fuse F11, F12, or F13 opens, Welder B (right) side output is erratic or low. If fuse F21, F22, or F23 opens, Welder A (left) side output is erratic or low.

- 10 Thermostats TP3 And TP4 (Internal – Not Shown)

Thermostat TP3 protects Welder A (left) SR2 rectifier and TP4 protects Welder B (right) SR3 rectifier from overheating. If TP3 or TP4 opens, Welder A (left) or Welder B (right) weld output stops and the High Temp. Shutdown light goes on. Wait fifteen minutes for module to cool and thermostat to automatically reset. Reduce amperage, voltage, or duty cycle before welding.

## 8-12. Troubleshooting

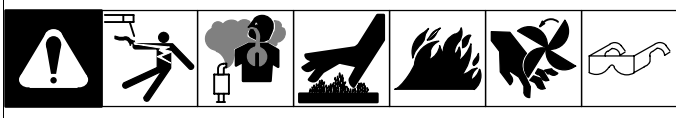

### A. Welding

Trouble	Remedy
No weld output on either side; generator power output okay at ac receptacles.	Place Output (Contactor) switches in On (Hot) position, or place switches in Remote position and connect remote contactors to remote receptacles RC8 and RC9 (see Section 6-3).
	Unit overheated (High Temp. Shutdown light goes on); wait several minutes for thermostat(s) TP3 and TP4 to reset (see Section 8-11).
	Check position of Process Selector switches and Welder Selector switch. All weld output stops if either Process Selector switch is placed in CV position when Welder Selector switch is in Welder B position (see Sections 6-1 and 6-3).
	Check fuse F2, and replace if open (see Section 8-11). Have Factory Authorized Service Agent check field current regulator board PC4.
	Have Factory Authorized Service Agent check field current regulator board PC4 and Welder Selector switch S2.
No weld output on either side and no generator power output at ac receptacles.	Disconnect equipment from generator power receptacles during start-up.
	Check fuse F1, and replace if open (see Section 8-11).
	Reset circuit breakers CB7 and/or CB8 (see Section 8-11).
	Have Factory Authorized Service Agent check brushes and slip rings, field excitation circuit, rotor, stator, and field current regulator board PC4.
No Welder A (left) weld output; Welder B (right) weld output okay.	Check fuse F3, and replace if open (see Section 8-11).
	Check position of Welder Selector switch. Welder A (left) weld output stops when Welder Selector switch is placed in Welder B position (see Section 6-1).
	Unit overheated (High Temp. Shutdown light goes on); wait several minutes for thermostat(s) TP3 to reset (see Section 8-11).
	Have Factory Authorized Service Agent check Welder A (left) contactor circuit.
No Welder B (right) weld output; Welder A (left) weld output okay;	Check fuse F4, and replace if open (see Section 8-11).
	Unit overheated (High Temp. Shutdown light goes on); wait several minutes for thermostat(s) TP4 to reset (see Section 8-11).
	Have Factory Authorized Service Agent check Welder B (right) contactor circuit.
Low Welder A (left) weld output; Welder B (right) output okay.	Check position of Process Selector switch (see Section 6-3).
	Increase Amperage/Voltage control setting.
	Check fuses F21, F22, and F23, and replace if open. If fuse(s) are open, have Factory Authorized Service Agent check main rectifier SR2.
	Have Factory Authorized Service Agent check main rectifier SR2, synchronization transformers T5, T6 and T7, and control board PC1.
Low Welder B (right) weld output; Welder A (left) weld output okay.	Check position of Process Selector switch (see Section 6-3).
	Increase Amperage/Voltage control setting.
	Check fuses F11, F12, and F13, and replace if open. If fuse(s) are open, have Factory Authorized Service Agent check main rectifier SR3.
	Have Factory Authorized Service Agent check main rectifier SR3, synchronization transformers T8, T9 and T10, and control board PC5.

Trouble	Remedy
Low weld output on both sides.	Check engine speed, and adjust if necessary (see Section 8-5).
	Check position of Process Selector switch(s) (see Section 6-3).
	Increase Amperage/Voltage controls settings.
	Have Factory Authorized Service Agent check field current regulator board PC4.
High weld output on both sides.	Have Factory Authorized Service Agent check field current regulator board PC4.
Erratic weld output on either side.	Check and tighten connections inside and outside unit.
	Be sure connection to work piece is clean and tight.
	Use dry, properly stored electrodes.
	Remove excessive coils from weld cables.
	Check Process Selector switch(s) connections and contacts.
	Welder A (left) side: check fuses F21, F22, and F23, and replace if open. If fuse(s) are open, have Factory Authorized Service Agent check main rectifier SR2.
	Welder B (right) side: check fuses F11, F12, and F13, and replace if open. If fuse(s) are open, have Factory Authorized Service Agent check main rectifier SR3.
Low open-circuit voltage on both sides.	Check engine speed, and adjust if necessary (see Section 8-5).
	Have Factory Authorized Service Agent check field current regulator board PC4.
Low open-circuit voltage on either side.	Increase Amperage/Voltage control setting.
	Welder A (left) side: check fuses F21, F22, and F23, and replace if open. If fuse(s) are open, have Factory Authorized Service Agent check main rectifier SR2.
	Welder B (right) side: check fuses F11, F12, and F13, and replace if open. If fuse(s) are open, have Factory Authorized Service Agent check main rectifier SR3.
	Have Factory Authorized Service Agent check main rectifiers SR2 and SR3, synchronization transformers T5 thru T10, and control board PC1 or PC5.
No control of weld output on either side.	Place A/V Control switch in Panel position, or place switch in Remote position and connect remote control to remote receptacle RC8 or RC9 (see Sections 5-17 and 6-3).
	Have Factory Authorized Service Agent check control board PC1 or PC5.
No voltage control on either side; open-circuit voltage present.	Repair or replace remote device.
	Place A/V Control switch in Panel position, or place switch in Remote position and connect remote control to remote receptacle RC8 or RC9 (see Sections 5-17 and 6-3).
	Check connections to Remote receptacle RC8 and RC9.
	Have Factory Authorized Service Agent check control board PC1 or PC5.
Wire feeder does not work (either side).	Reset Welder A (left) circuit breaker CB5 or Welder B (right) circuit breaker CB6 (see Section 8-11).
	Check position of Process Selector switches and Welder Selector switch. All weld output stops if either Process Selector switch is placed in CV position when Welder Selector switch is in Welder B position (see Sections 6-1 and 6-3).
	Check connections to Remote 14 receptacle RC8 (see Section 5-17).
	Place optional Polarity switches in Reverse position. There is no CV weld output when Polarity switch is in Straight position.
	Have Factory Authorized Service Agent check brushes and slip rings, and field excitation circuit.
	Repair or replace wire feeder.

## B. Generator Power

Trouble	Remedy
No output at generator power ac receptacles.	Reset receptacle circuit breakers (see Section 7-1).
	Press GFCI reset button on 120 volt GFCI receptacles (see Section 7-1).
	Check fuse F1, and replace if open (see Section 8-11).
	Check receptacle(s) for continuity and proper connections. Replace receptacle(s) if necessary.
	Have Factory Authorized Service Agent check brushes and slip rings.
High or low output at generator power ac receptacles.	Check engine speed, and adjust if necessary (see Section 8-5).

## C. Engine

Trouble	Remedy
Engine will not crank.	Check battery voltage, and replace battery if necessary.
	Check battery connections and tighten if necessary.
	Have Factory Authorized Service Agent check Engine Start Button PB1.
Engine cranks but does not start.	Check fuel level (see Section 5-5).
	Open fuel valve (see Section 5-5).
	Check battery voltage, and replace battery if necessary.
	Check blower fan V-belt according to engine manual. Safety shutdown stops engine if belt is broken or loose (see Section 8-8).
	Check engine charging system according to engine manual.
	See engine manual.
Engine suddenly stops.	Check blower fan V-belt according to engine manual. Safety shutdown stops engine if belt is broken or loose (see Section 8-8).
	See engine manual.
Battery discharges between uses.	Clean battery, terminals, and posts with baking soda and water solution; rinse with clear water.
	Periodically recharge battery (approximately every 3 months).
	Replace battery.
	Check voltage regulator and connections according to engine manual.
Engine uses oil during run-in period; wetstacking occurs.	Dry engine (see Section 10).





# SECTION 9 - ELECTRICAL DIAGRAMS

SIDE-A

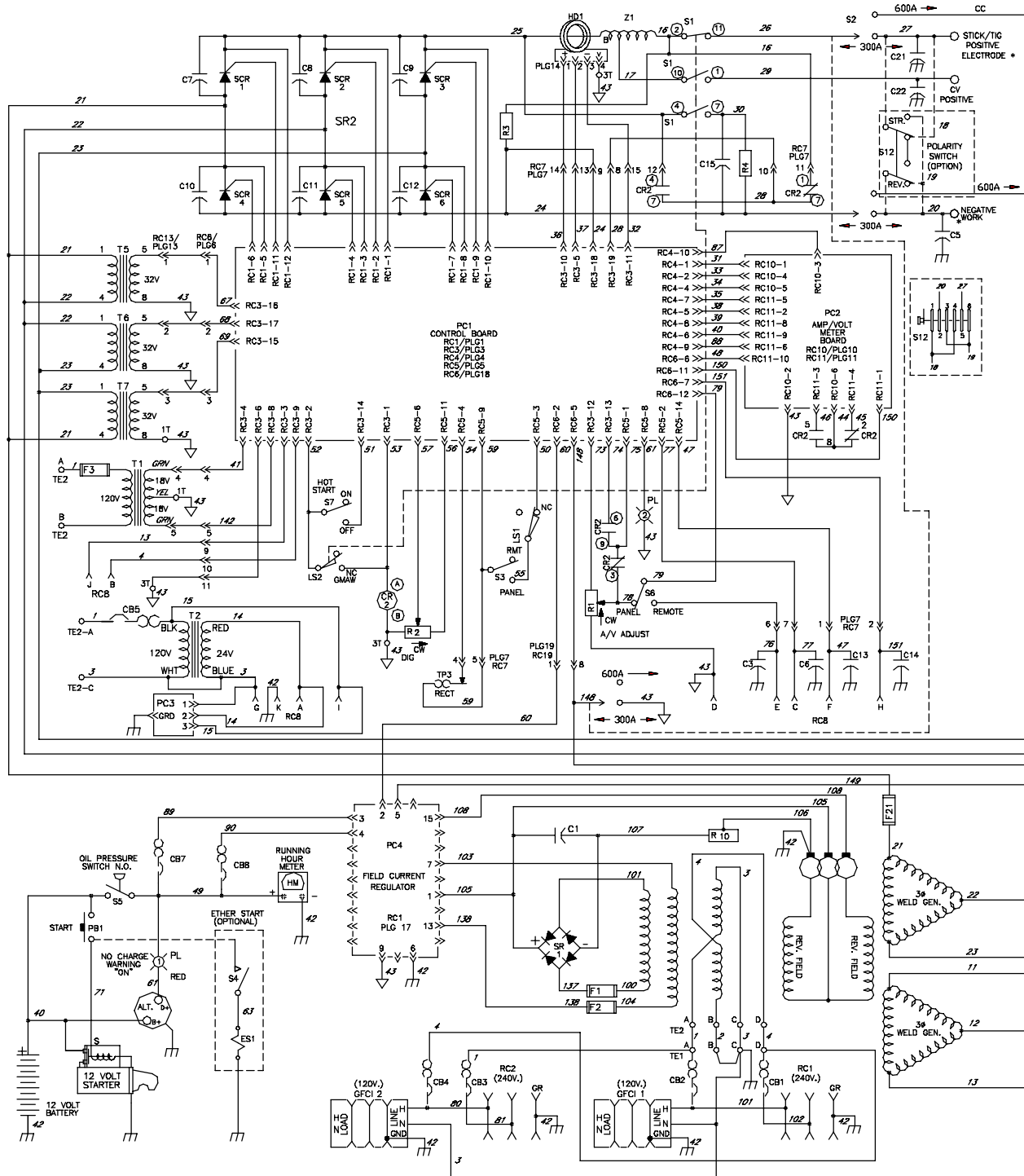

Figure 9-1. Circuit Diagram For Welding Generator

**⚠ WARNING**

- Do not touch live electrical parts.
- Disconnect input power or stop engine before servicing.
- Do not operate with covers removed.
- Have only qualified persons install, use, or service this unit.

**ELECTRIC SHOCK HAZARD**

SIDE-B

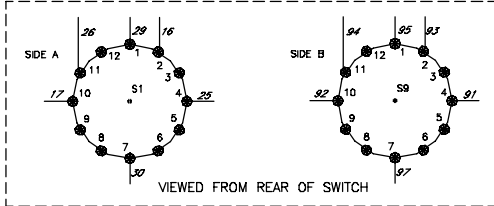
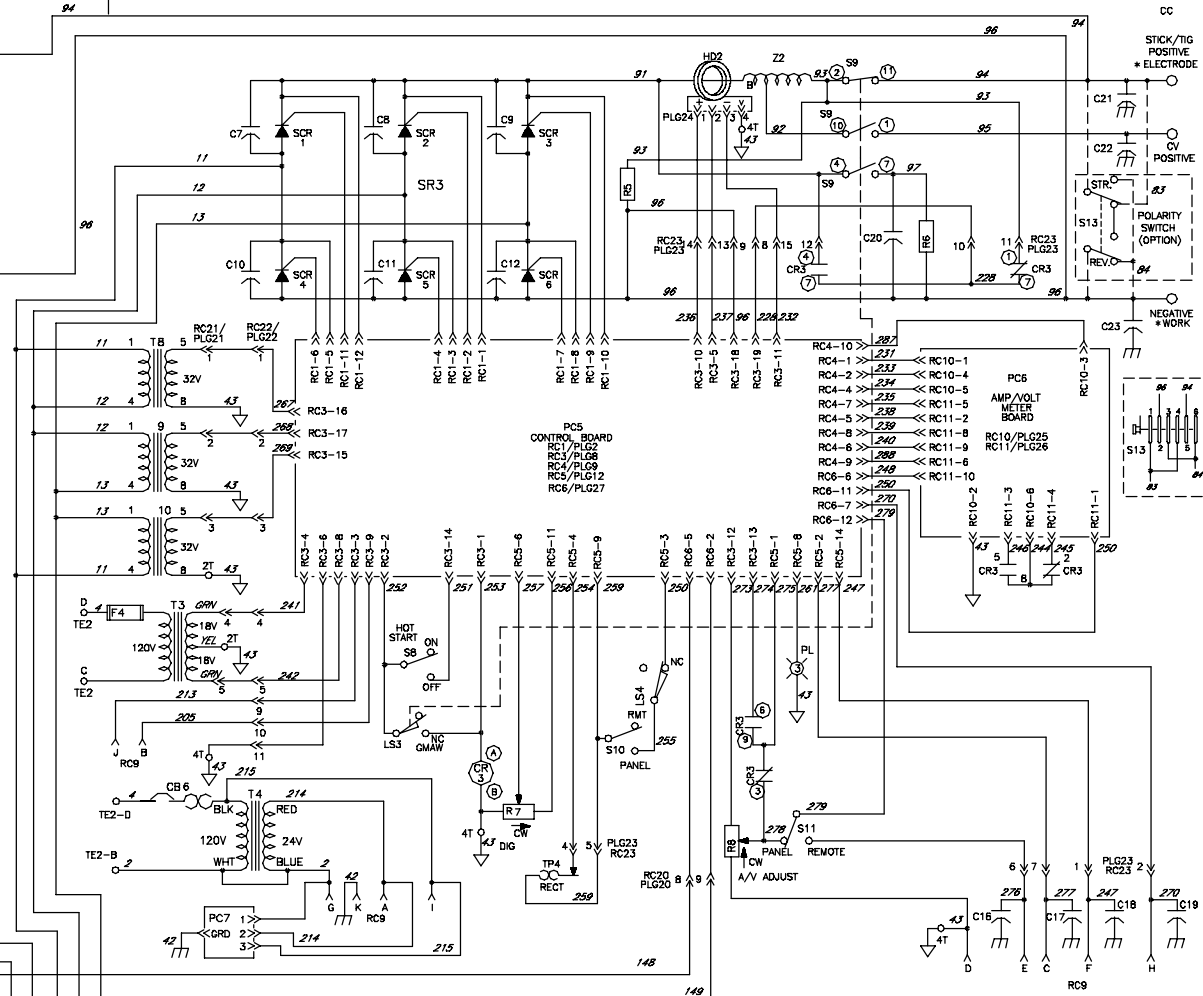

PC1 SIDE A	RC19/PLG18	RC20/PLG20	PC5 SIDE B
RCB-14	3 143	3	RCB-14
RCB-8	4 144	4	RCB-10
RCB-13	5 145	5	RCB-3
RCB-9	6 146	6	RCB-9
RCB-1	7 147	7	RCB-1

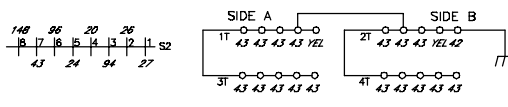

\* WITH THE POLARITY SWITCH OPTION LEADS 20 & 27 ON SIDE A AND LEADS 94 & 96 ON SIDE B GO TO THE POLARITY SWITCH RATHER THAN THE OUTPUT STUDS. THE OUTPUT STUDS ARE LABELED ELECTRODE AND WORK.

# SECTION 10 – RUN-IN PROCEDURE

run\_in3 B/01

## 10-1. Wetstacking

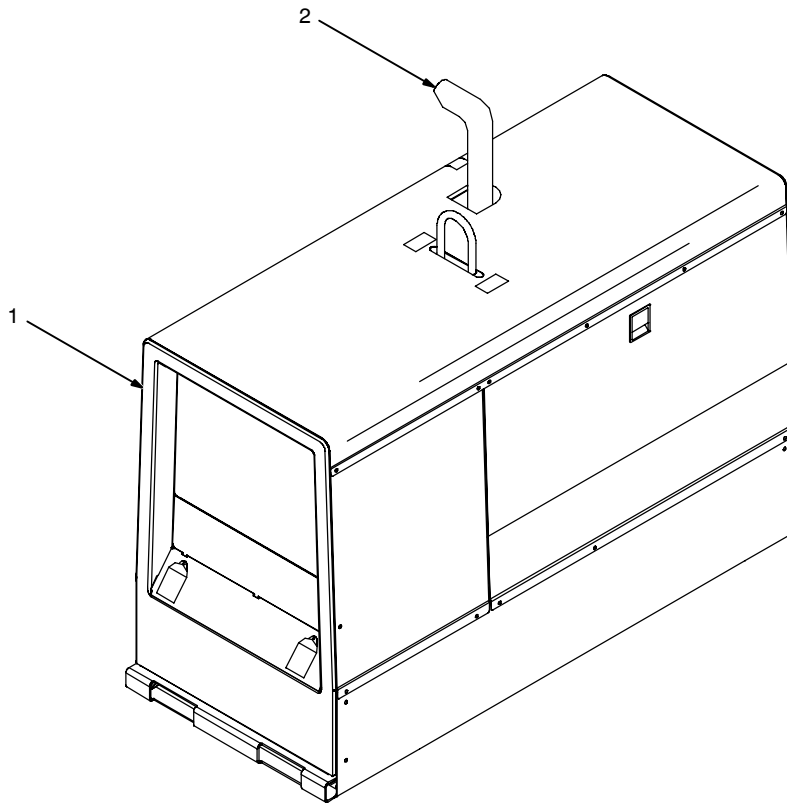

▲ **Do not perform run-in procedure at less than 20 volts weld output and do not exceed duty cycle or equipment damage may occur.**

### 1 Welding Generator

Run diesel engines near rated voltage and current during run-in period to properly seat piston rings and prevent wetstacking. See nameplate, rating label, or specifications section in this manual to find rated voltage and current.

☞ *Do not idle engine longer than necessary. Piston rings seat faster if engine runs at weld/power rpm, and the welding generator is kept loaded during run-in.*

### 2 Engine Exhaust Pipe

Wetstacking is unburned fuel and oil in the exhaust pipe and occurs during run-in if the engine is run too long at light load or idle rpm.

If exhaust pipe is coated with a wet, black, tar-like substance, dry the engine using one of the following run-in procedures.

See the engine manual for additional engine run-in information.

## 10-2. Run-In Procedure Using Load Bank

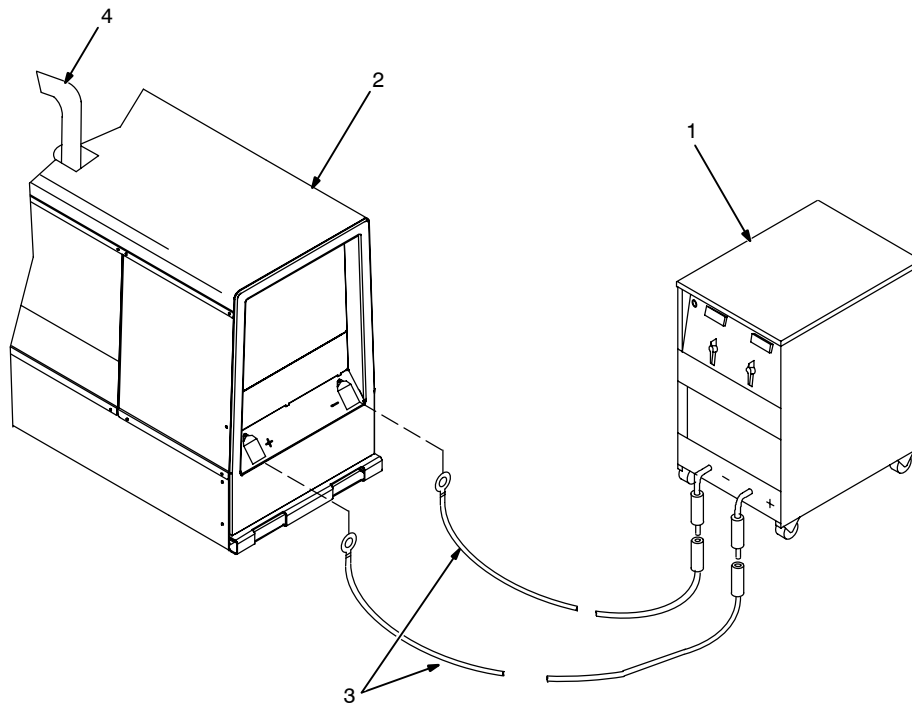

- ▲ **Stop engine.**
- ▲ **Do not touch hot exhaust pipe, engine parts, or load bank/grid.**
- ▲ **Keep exhaust and pipe away from flammables.**
- ▲ **Do not perform run-in procedure at less than 20 volts weld output and do not exceed duty cycle or equipment damage may occur.**

### 1 Load Bank

Turn all load bank switches Off. If needed, connect load bank to 115 volts ac wall receptacle or generator auxiliary power receptacle.

### 2 Welding Generator

Place Welder Selector switch in Welder B position (600 Amps), A/V control in minimum position, and both Process Selector switches in Stick/TIG position.

### 3 Weld Cables

Connect load bank to generator Welder B (right) weld output terminals using proper size weld cables with correct connectors. Observe correct polarity.

Start engine and run for several minutes.

Set load bank switches and then adjust generator A/V control so load equals 350 Amps at 40 volts.

Check generator and load bank meters after first five minutes then every fifteen minutes to be sure generator is loaded properly.

*Check oil level frequently during run-in; add oil if needed.*

After one hour (minimum) place A/V control in minimum position, then turn off load bank to remove load. Run engine several minutes at no load.

### ▲ **Stop engine and let cool.**

### 4 Engine Exhaust Pipe

Repeat procedure if wetstacking is present.

## 10-3. Run-In Procedure Using Resistance Grid

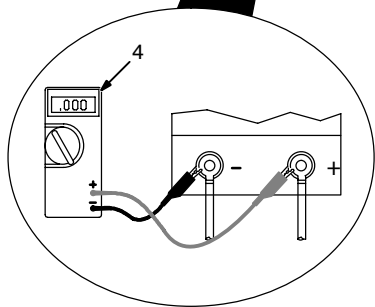
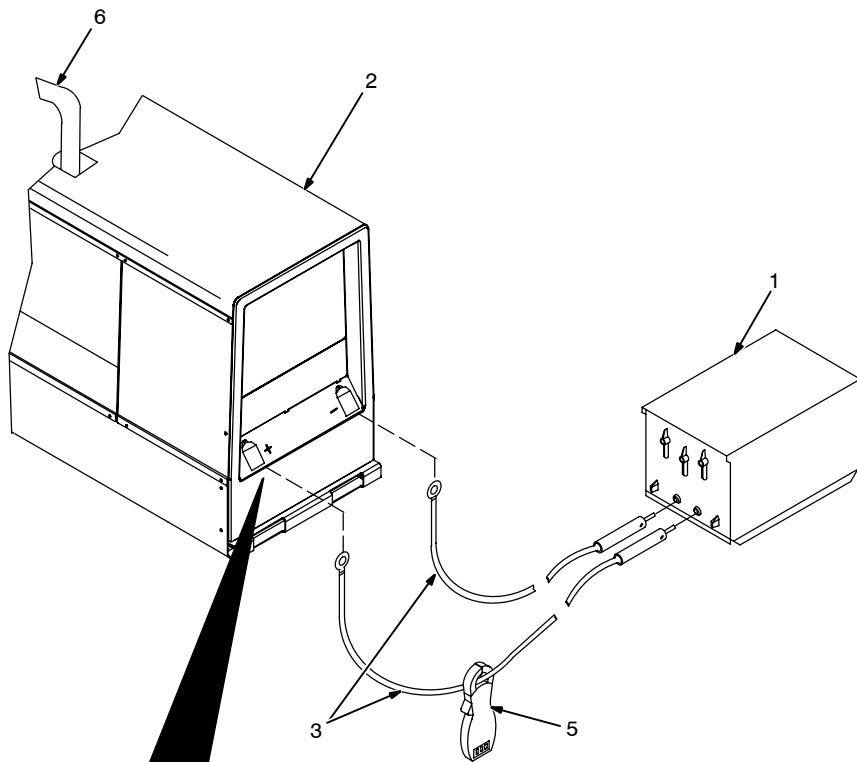

- ▲ **Stop engine.**
- ▲ **Do not touch hot exhaust pipe, engine parts, or load bank/grid.**
- ▲ **Keep exhaust and pipe away from flammables.**
- ▲ **Do not perform run-in procedure at less than 20 volts weld output and do not exceed duty cycle or equipment damage may occur.**

### 1 Resistance Grid

Use grid sized for generator rated output.

Turn Off grid.

### 2 Welding Generator

Place Welder Selector switch in Welder B position (600 Amps), A/V control in minimum position, and both Process Selector switches in Stick/TIG position.

### 3 Weld Cables

Connect grid to generator Welder B (right) weld output terminals using proper size weld cables with correct connectors (polarity is not important).

### 4 Voltmeter

### 5 Clamp-On Ammeter

Connect voltmeter and ammeter as shown, if not provided on generator.

Start engine and run for several minutes.

Set grid switches and then adjust generator A/V control so load equals 350 Amps at 40 volts.

Check generator and meters after first five minutes then every fifteen minutes to be sure generator is loaded properly.

☞ *Check oil level frequently during run-in; add oil if needed.*

After one hour (minimum), place A/V control in minimum position, then shut down grid to remove load. Run engine several minutes at no load.

- ▲ **Stop engine and let cool.**

### 6 Engine Exhaust Pipe

Repeat procedure if wetstacking is present.

# SECTION 11 – GENERATOR POWER GUIDELINES

## NOTE

The views in this section are intended to be representative of all engine-driven welding generators. Your unit may differ from those shown.

### 11-1. Selecting Equipment

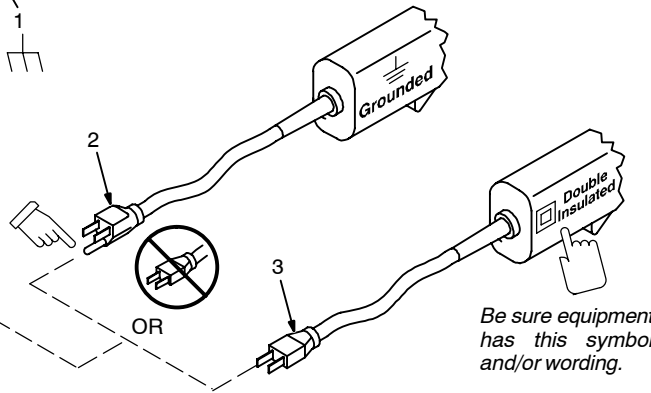
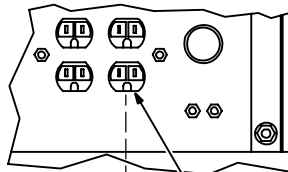

- 1 Generator Power Receptacles – Neutral Bonded To Frame
  - 2 3-Prong Plug From Case Grounded Equipment
  - 3 2-Prong Plug From Double Insulated Equipment
- ▲ **Do not use 2-prong plug unless equipment is double insulated.**

gen\_pwr 11/02 – Ref. ST-159 730 / ST-800 577

### 11-2. Grounding Generator To Truck Or Trailer Frame

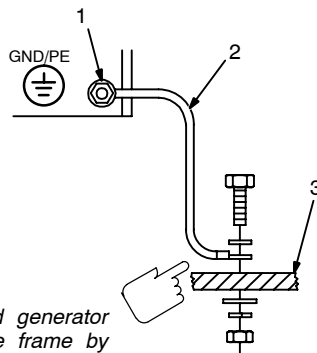
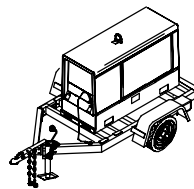
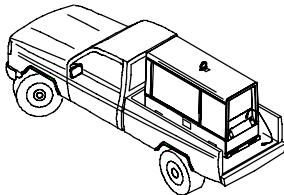

Electrically bond generator frame to vehicle frame by metal-to-metal contact.

- ▲ **Bed liners, shipping skids, and some running gear insulate the welding generator from the vehicle frame. Always connect a ground wire from the generator equipment grounding terminal to bare metal on the vehicle frame as shown.**

- ▲ **Always ground generator frame to vehicle frame to prevent electric shock and static electricity hazards.**

- 1 Equipment Grounding Terminal (On Front Panel)
- 2 Grounding Cable (Not Supplied)
- 3 Metal Vehicle Frame

Connect cable from equipment ground terminal to metal vehicle frame. Use #10 AWG or larger insulated copper wire.

- ▲ **If unit does not have GFCI receptacles, use GFCI-protected extension cord.**

S-0854

### 11-3. Grounding When Supplying Building Systems

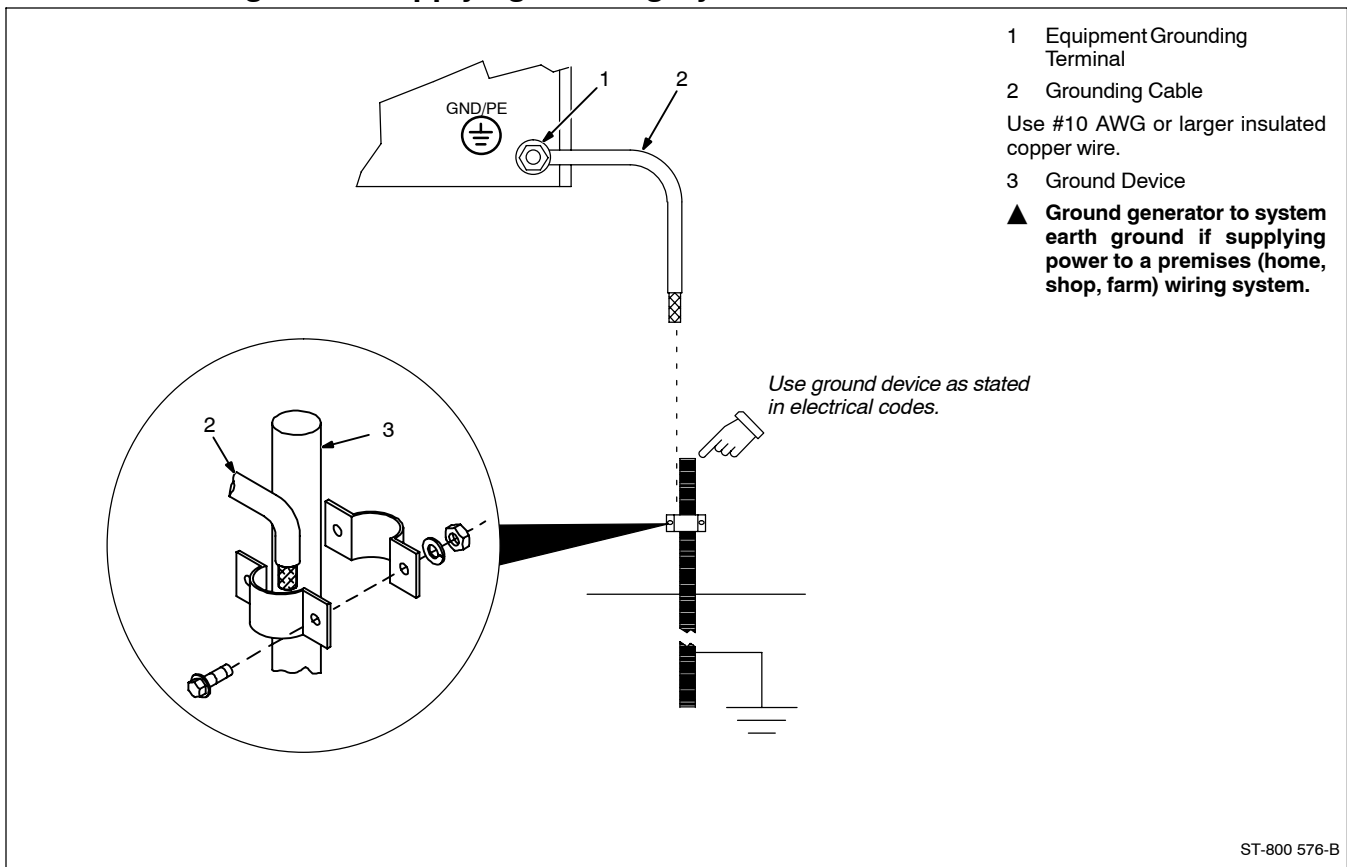

### 11-4. How Much Power Does Equipment Require?

VOLTS	115
AMPS	4.5
Hz	60

1 Resistive Load  
 A light bulb is a resistive load and requires a constant amount of power.

2 Non-Resistive Load  
 Equipment with a motor is a non-resistive load and requires approximately six times more power while starting the motor than when running (see Section 11-8).

3 Rating Data  
 Rating shows volts and amperes, or watts required to run equipment.

**AMPERES x VOLTS = WATTS**

**EXAMPLE 1:** If a drill uses 4.5 amperes at 115 volts, calculate its running power requirement in watts.

$4.5 A \times 115 V = 520 W$

The load applied by the drill is 520 watts.

**EXAMPLE 2:** If three 200 watt flood lamps are used with the drill from Example 1, add the individual loads to calculate total load.

$(200 W + 200 W + 200 W) + 520 W = 1120 W$

The total load applied by the three flood lamps and drill is 1120 watts.

S-0623



## 11-5. Approximate Power Requirements For Industrial Motors

Industrial Motors	Rating	Starting Watts	Running Watts
Split Phase	1/8 HP	800	300
	1/6 HP	1225	500
	1/4 HP	1600	600
	1/3 HP	2100	700
	1/2 HP	3175	875
Capacitor Start-Induction Run	1/3 HP	2020	720
	1/2 HP	3075	975
	3/4 HP	4500	1400
	1 HP	6100	1600
	1-1/2 HP	8200	2200
	2 HP	10550	2850
	3 HP	15900	3900
Capacitor Start-Capacitor Run	5 HP	23300	6800
	1-1/2 HP	8100	2000
	5 HP	23300	6000
	7-1/2 HP	35000	8000
Fan Duty	10 HP	46700	10700
	1/8 HP	1000	400
	1/6 HP	1400	550
	1/4 HP	1850	650
	1/3 HP	2400	800
	1/2 HP	3500	1100

## 11-6. Approximate Power Requirements For Farm/Home Equipment

Farm/Home Equipment	Rating	Starting Watts	Running Watts
Stock Tank De-Icer		1000	1000
Grain Cleaner	1/4 HP	1650	650
Portable Conveyor	1/2 HP	3400	1000
Grain Elevator	3/4 HP	4400	1400
Milk Cooler		2900	1100
Milker (Vacuum Pump)	2 HP	10500	2800
FARM DUTY MOTORS	1/3 HP	1720	720
Std. (e.g. Conveyors,	1/2 HP	2575	975
Feed Augers, Air	3/4 HP	4500	1400
Compressors)	1 HP	6100	1600
	1-1/2 HP	8200	2200
	2 HP	10550	2850
	3 HP	15900	3900
	5 HP	23300	6800
High Torque (e.g. Barn	1-1/2 HP	8100	2000
Cleaners, Silo Unloaders,	5 HP	23300	6000
Silo Hoists, Bunk Feeders)	7-1/2 HP	35000	8000
	10 HP	46700	10700
3-1/2 cu. ft. Mixer	1/2 HP	3300	1000
High Pressure 1.8 Gal/Min	500 PSI	3150	950
Washer 2 gal/min	550 PSI	4500	1400
2 gal/min	700 PSI	6100	1600
Refrigerator or Freezer		3100	800
Shallow Well Pump	1/3 HP	2150	750
	1/2 HP	3100	1000
Sump Pump	1/3 HP	2100	800
	1/2 HP	3200	1050

## 11-7. Approximate Power Requirements For Contractor Equipment

Contractor	Rating	Starting Watts	Running Watts
Hand Drill	1/4 in	350	350
	3/8 in	400	400
	1/2 in	600	600
Circular Saw	6-1/2 in	500	500
	7-1/4 in	900	900
	8-1/4 in	1400	1400
Table Saw	9 in	4500	1500
	10 in	6300	1800
Band Saw	14 in	2500	1100
Bench Grinder	6 in	1720	720
	8 in	3900	1400
	10 in	5200	1600
Air Compressor	1/2 HP	3000	1000
	1 HP	6000	1500
	1-1/2 HP	8200	2200
	2 HP	10500	2800
Electric Chain Saw	1-1/2 HP, 12 in	1100	1100
	2 HP, 14 in	1100	1100
Electric Trimmer	Standard 9 in	350	350
	Heavy Duty 12 in	500	500
Electric Cultivator	1/3 HP	2100	700
Elec. Hedge Trimmer	18 in	400	400
Flood Lights	HID	125	100
	Metal Halide	313	250
	Mercury	1000	
	Sodium Vapor	1400	1000
Submersible Pump	400 gph	600	200
Centrifugal Pump	900 gph	900	500
Floor Polisher	3/4 HP, 16 in	4500	1400
	1 HP, 20 in	6100	1600
High Pressure Washer	1/2 HP	3150	950
	3/4 HP	4500	1400
	1 HP	6100	1600
55 gal Drum Mixer	1/4 HP	1900	700
Wet & Dry Vac	1.7 HP	900	900
	2-1/2 HP	1300	1300

## 11-8. Power Required To Start Motor

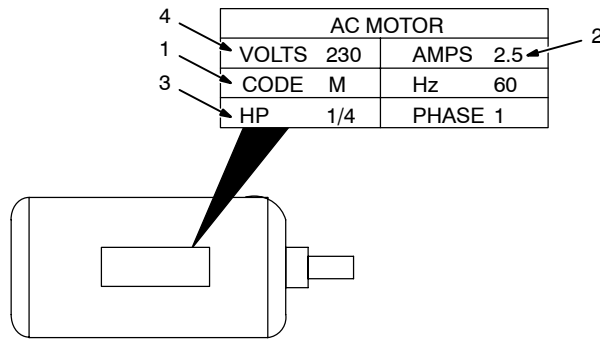

- 1 Motor Start Code
- 2 Running Amperage
- 3 Motor HP
- 4 Motor Voltage

To find starting amperage:

**Step 1:** Find code and use table to find kVA/HP. If code is not listed, multiply running amperage by six to find starting amperage.

**Step 2:** Find Motor HP and Volts.

**Step 3:** Determine starting amperage (see example).

Welding generator amperage output must be at least twice the motor's running amperage.

Single-Phase Induction Motor Starting Requirements

Motor Start Code	G	H	J	K	L	M	N	P
KVA/HP	6.3	7.1	8.0	9.0	10.0	11.2	12.5	14.0

$$\frac{\text{kVA/HP} \times \text{HP} \times 1000}{\text{VOLTS}} = \text{STARTING AMPERAGE}$$

**EXAMPLE:** Calculate the starting amperage required for a 230 V, 1/4 HP motor with a motor start code of M.

Volts = 230    HP = 1/4    Using Table, Code M results in kVA/HP = 11.2

$$\frac{11.2 \times 1/4 \times 1000}{230} = 12.2 \text{ A} \quad \text{Starting the motor requires 12.2 amperes.}$$

S-0624

## 11-9. How Much Power Can Generator Supply?

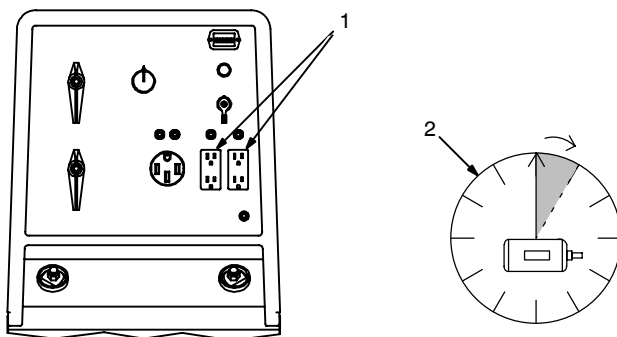

- 1 Limit Load To 90% Of Generator Output

Always start non-resistive (motor) loads in order from largest to smallest, and add resistive loads last.

- 2 5 Second Rule

If motor does not start within 5 seconds, turn off power to prevent motor damage. Motor requires more power than generator can supply.

Ref. ST-800 396-A / S-0625



## 11-11. Selecting Extension Cord (Use Shortest Cord Possible)



### Cord Lengths for 120 Volt Loads

▲ If unit does not have GFCI receptacles, use GFCI-protected extension cord.

Current (Amperes)	Load (Watts)	Maximum Allowable Cord Length in ft (m) for Conductor Size (AWG)*					
		4	6	8	10	12	14
5	600			350 (106)	225 (68)	137 (42)	100 (30)
7	840		400 (122)	250 (76)	150 (46)	100 (30)	62 (19)
10	1200	400 (122)	275 (84)	175 (53)	112 (34)	62 (19)	50 (15)
15	1800	300 (91)	175 (53)	112 (34)	75 (23)	37 (11)	30 (9)
20	2400	225 (68)	137 (42)	87 (26)	50 (15)	30 (9)	
25	3000	175 (53)	112 (34)	62 (19)	37 (11)		
30	3600	150 (46)	87 (26)	50 (15)	37 (11)		
35	4200	125 (38)	75 (23)	50 (15)			
40	4800	112 (34)	62 (19)	37 (11)			
45	5400	100 (30)	62 (19)				
50	6000	87 (26)	50 (15)				

\*Conductor size is based on maximum 2% voltage drop

### Cord Lengths for 240 Volt Loads

▲ If unit does not have GFCI receptacles, use GFCI-protected extension cord.

Current (Amperes)	Load (Watts)	Maximum Allowable Cord Length in ft (m) for Conductor Size (AWG)*					
		4	6	8	10	12	14
5	1200			700 (213)	450 (137)	225 (68)	200 (61)
7	1680		800 (244)	500 (152)	300 (91)	200 (61)	125 (38)
10	2400	800 (244)	550 (168)	350 (107)	225 (69)	125 (38)	100 (31)
15	3600	600 (183)	350 (107)	225 (69)	150 (46)	75 (23)	60 (18)
20	4800	450 (137)	275 (84)	175 (53)	100 (31)	60 (18)	
25	6000	350 (107)	225 (69)	125 (38)	75 (23)		
30	7000	300 (91)	175 (53)	100 (31)	75 (23)		
35	8400	250 (76)	150 (46)	100 (31)			
40	9600	225 (69)	125 (38)	75 (23)			
45	10,800	200 (61)	125 (38)				
50	12,000	175 (53)	100 (31)				

\*Conductor size is based on maximum 2% voltage drop

# SECTION 12 – PARTS LIST

 Hardware is common and not available unless listed.

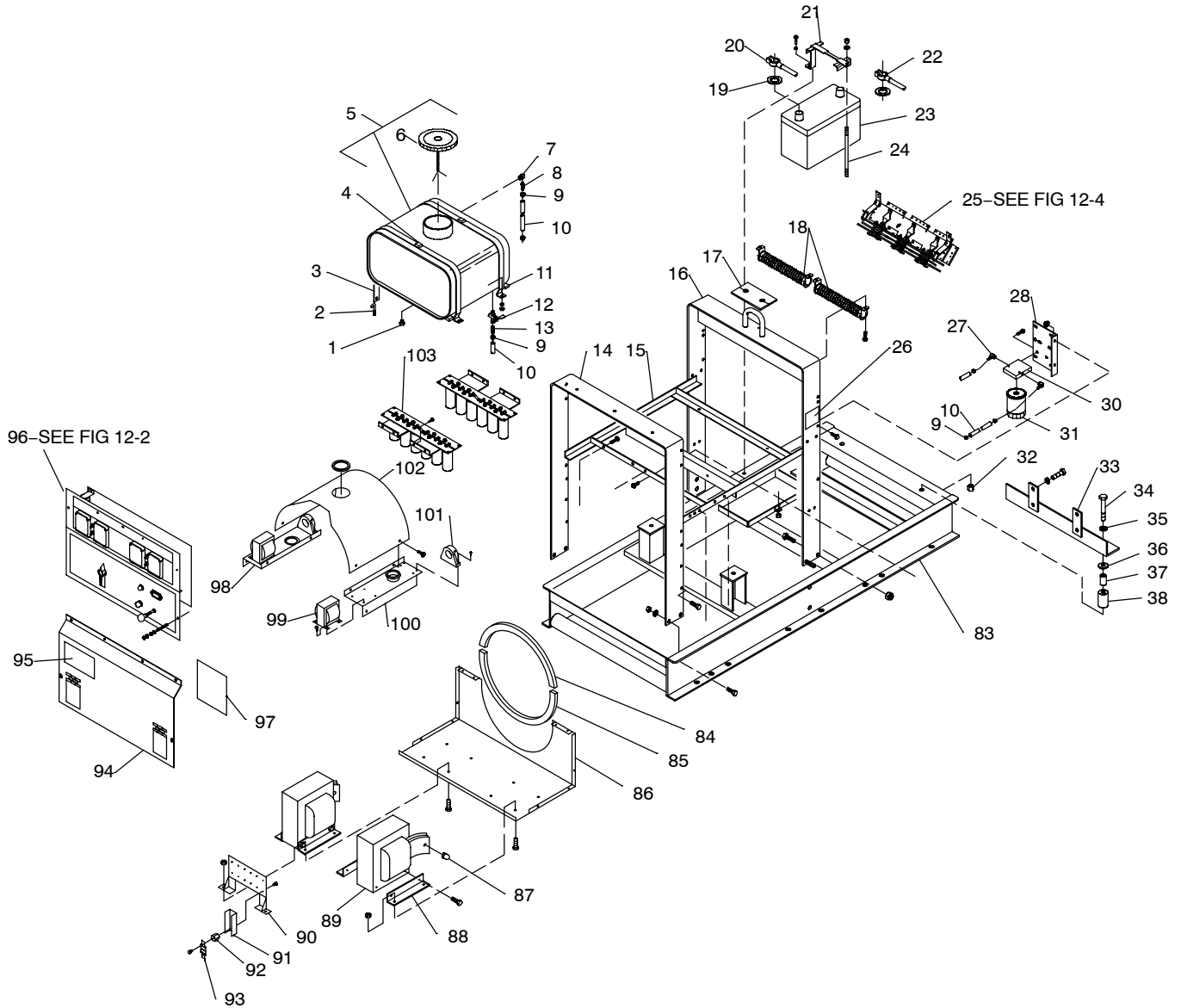
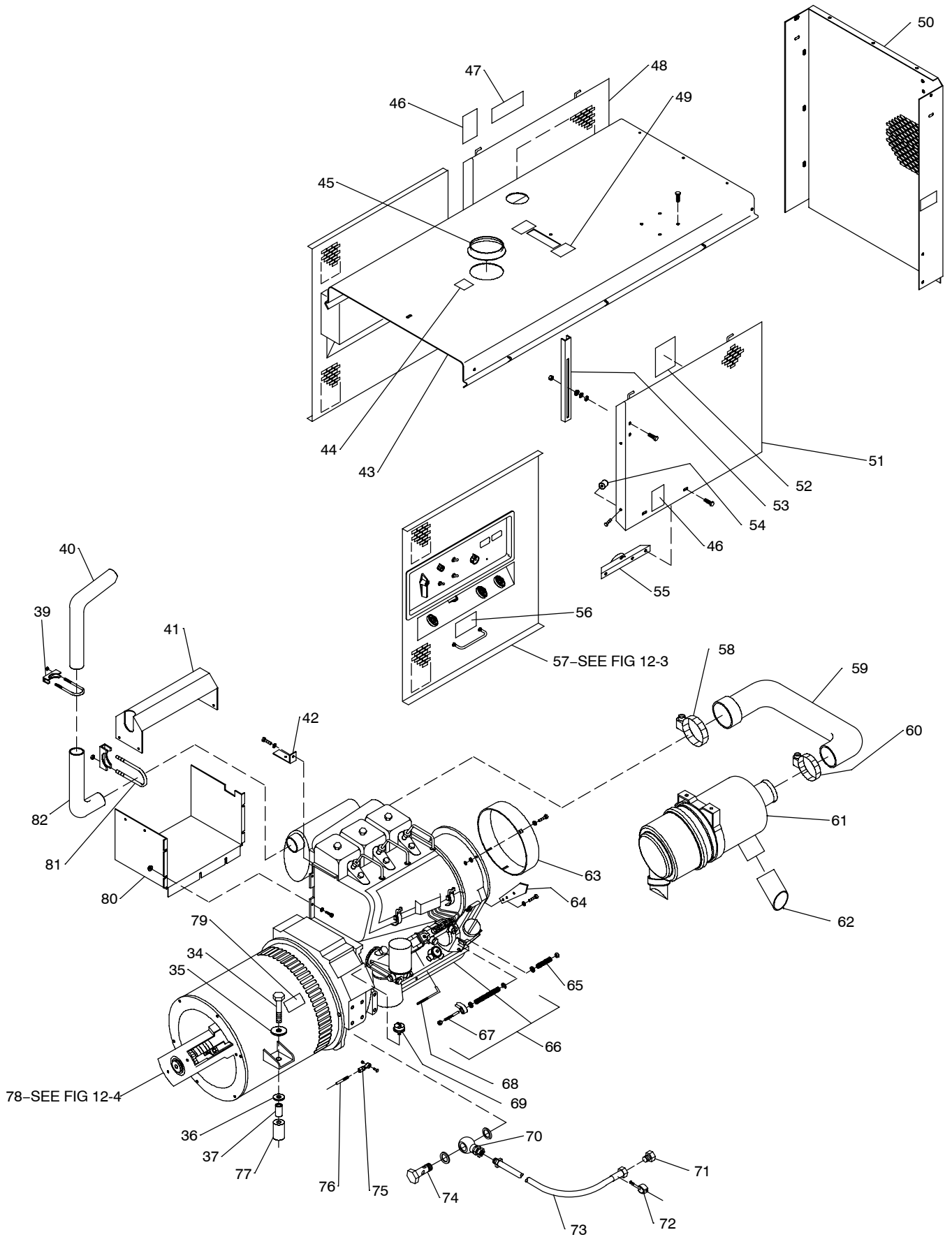

Figure 12-1. Main Assembly



Item No.	Dia. Mkgs.	Part No.	Description	Quantity
<b>Figure 12-1. Main Assembly</b>				
1		605 288	FITTING, pipe galv plug sqhd .250NPT	1
2		070 010	BOLT, J stl .250-20 x 2.750 pld	2
3		088 696	STRAP, hold down fuel tank	2
4		134 771	PLUG, protective .640sq	2
5		184 675	TANK, fuel 22.3gal (consisting of)	1
6		182 022	CAP, fuel	1
7		020 185	FITTING, pipe brs elbow st 1/8NPT	1
8		053 525	FITTING, hose brs barbed M 5/16tbg x 1/8NPT	1
9		172 071	CLAMP, hose .520-.605clp dia slfng	6
10		134 835	HOSE, SAE .312 ID x .560 OD (order by ft)	9ft
11		097 507	STRIP, rbr adh back .125 x 1.000 x 20.500 60 duro	2
12		175 432	VALVE, shut-off fuel	1
13		039 599	FITTING, brs barbed M 5/16 tbg x 1/4 NPT	1
14		+048 227	UPRIGHT, base front	1
15		170 689	FRAME, mtg reactor and fuel tank	1
16		+170 617	UPRIGHT, base center	1
17		017 479	SEAL, weather lift eye	1
18	R3, R5	097 459	RESISTOR, WW fxd 375W 20 ohm	2
19		108 081	TERMINAL PROTECTOR, battery post mtg	2
20		182 276	CABLE, bat pos	1
21		208 353	HOLD DOWN, battery	1
22		032 453	CABLE, bat neg	1
23		190 896	BATTERY, stor 12v 660 crk 110 rsv gp 24 low	1
24		010 460	STUD, stl .312-18 x 10.000	1
25	SR2, SR3	Figure 12-5	RECTIFIER ASSEMBLY	1
26		176 697	LABEL, fuel shut-off	1
27		145 282	FITTING, hose brs barbed elbow M 5/16tbg x 1/4NPT	2
28		083 859	BRACKET, mtg fuel filter	1
29		Deleted		
30		202 242	BASE, fuel filter assy	1
31		192 744	SEPARATOR, fuel filter & water	1
32		135 205	NUT, 625-11 .94 hex .76H stl pld	8
33		116 707	SUPPORT, front engine	1
34		119 849	SCREW, 625-11 x 4.00 hexhd pln gr 5 pld	4
35		071 731	WASHER, flat stl .656 ID x 2.250 OD x .187thk	4
36		071 890	RETAINER, mount eng/gen	4
37		071 730	TUBING, stl .875 OD x 12ga wall x 2.500	4
38		072 848	MOUNT, eng/gen nprn .875 ID x 2.500 OD x 2.000 50 dur	2
39		010 875	CLAMP, muffler 2.000 dia	1
40		105 734	PIPE, muffler extension elbow 1.875 OD	1
41		176 232	BAFFLE, air muffler exhaust	1
42		048 216	BRACKET, mtg breather	1
43		+105 909	COVER, top	1
44		192 041	LABEL, use diesel fuel only	1
45		035 968	WASHER, flat rbr 3.625 ID x 5.875 OD x .062thk	1
46		158 610	LABEL, warning electric shock	2
47		168 385	LABEL, warning battery explosion	1
48		+192 313	DOOR, side LH	1
49		222 513	LABEL, warning falling equipment can cause serious	2
50		117 257	PANEL, end engine	1
51		+192 314	DOOR, side RH	1
52		181 642	LABEL, diesel engine maintenance	1
53		004 130	BRACKET, support door	2
54		087 341	BUMPER, door 1.000 OD x .750 high	4
55		087 336	LATCH	2
56		027 434	LABEL, welder will not start by applying power to terminals	2
57		Figure 12-3	SIDE CONTROL PANELS	2
58		023 313	CLAMP, hose 3.250-3.000 clp dia slftg	1
59		201 547	HOSE, air cleaner w/spring	1
60		010 863	CLAMP, hose 2.062 - 3.000 clp slftg	1



Item No.	Dia. Mkgs.	Part No.	Description	Quantity
<b>Figure 12-1. Main Assembly (Continued)</b>				
61		189 764	AIR CLEANER, intake	1
		*192 938	FILTER, air element primary	1
		*♦192 939	FILTER, air element safety	1
		203 462	BRACKET, mtg air cleaner	1
62		165 785	HOSE, air cleaner 2.437 ID	1
63		048 213	BAFFLE, air intake	1
		194 467	WASHER, flat (for baffle) 6.25 ID x 11.50 OD x .62 T buna	1
64			LEVER, trip shutdown (included w/engine – see engine parts list)	1
65			SPRING (included w/engine – see engine parts list)	1
66		181 634	ENGINE, dsl electric (consisting of)	1
67		087 371	ROD, shutdown	1
		*064 677	FILTER, oil	1
		*062 342	FILTER, fuel primary	1
		*064 686	FILTER, fuel secondary	1
		*064 690	BELT, blower	1
68		070 661	ROD, speed control	1
69		151 969	SWITCH, pressure 4PSI N/O	1
70		♦047 361	FITTING, banjo	1
71		♦089 351	FITTING, pipe brs plug hexhd 1/2NPT	1
72		♦192 197	BRACKET, mounting	1
73		♦008 114	HOSE, oil w/fittings 17.500 lg	1
74		♦047 234	BOLT, banjo	1
		♦047 235	WASHER, oil seal copper	2
75		127 994	BALL JOINT, .250-28	1
76		162 740	STUD, stl .250-28 x 45.000	1
77		083 476	MOUNT, eng/gen nprn .875 ID x 2.500 OD x 2.000 60 dur	2
78		Figure 12-4	GENERATOR	1
79		225 120	LABEL, warning moving parts can cause injury	2
80		176 236	BAFFLE, air outlet	1
81			CLAMP, muffler (included with engine)	1
82		105 733	PIPE, muffler extension elbow 1.875 OD	1
83		165 739	BASE	1
84		191 446	EXTRUSION, rubber w/adhesive 1.000 x 1.000 D (order by ft)	2.1ft
85		173 352	EXTRUSION, rubber clamp/bulb (order by ft)	2.4ft
86		192 305	TRAY, base	1
87		176 167	NUT, 250-20 acorn nylon	6
88		192 303	ANGLE, mtg stabilizer	4
89	Z1, Z2	192 296	STABILIZER	2
90		205 791	BRACKET, mtg fuse assembly (consisting of)	1
91		204 965	STRIP, insulation	6
92		026947	STAND-OFF, insul .250-20 x 1.0	12
93	F11-13, F21-23	027 267	FUSE, link 300 A 250 volt	6
94		192 304	PANEL, front lower	1
95		223 379	LABEL, warning general precautionary CSA	1
96		Figure 12-2	FRONT PANEL	1
97		175 256	INSULATOR, side rh	1
98		192 300	SHROUD, generator LH	1
99	T2, T4	192 371	TRANSFORMER, 115V pri 24VCT 8A w/leads	2
100		192 301	SHROUD, generator RH	1
101		168 829	TRANSDUCER, current 1000A module max open loop	2
102		192 299	SHROUD, generator center	1
103		194 021	CAPACITOR ASSEMBLY, (consisting of)	2
		162 817	BUS BAR, capacitor	2
	C15, C20	163 535	CAPACITOR, elctlt	6
	R4, R6	140 002	RESISTOR, WW fxd 10W	1
		162 799	BRACKET, mtg capacitors	2

Item No.	Dia. Mkgs.	Part No.	Description	Quantity
----------	------------	----------	-------------	----------

**Figure 12-1. Main Assembly (Continued)**

.....	201 915	..	KIT, label (includes safety and informational labels)	1
.....	201 916	..	KIT, label (includes safety and informational labels)	1
.....			(Models w/opt. Polarity Switch)	1

+When ordering a component originally displaying a precautionary label, the label should also be ordered.

\*Recommended Spare Parts.

◆OPTIONAL

**To maintain the factory original performance of your equipment, use only Manufacturer's Suggested Replacement Parts. Model and serial number required when ordering parts from your local distributor.**

 Hardware is common and not available unless listed.

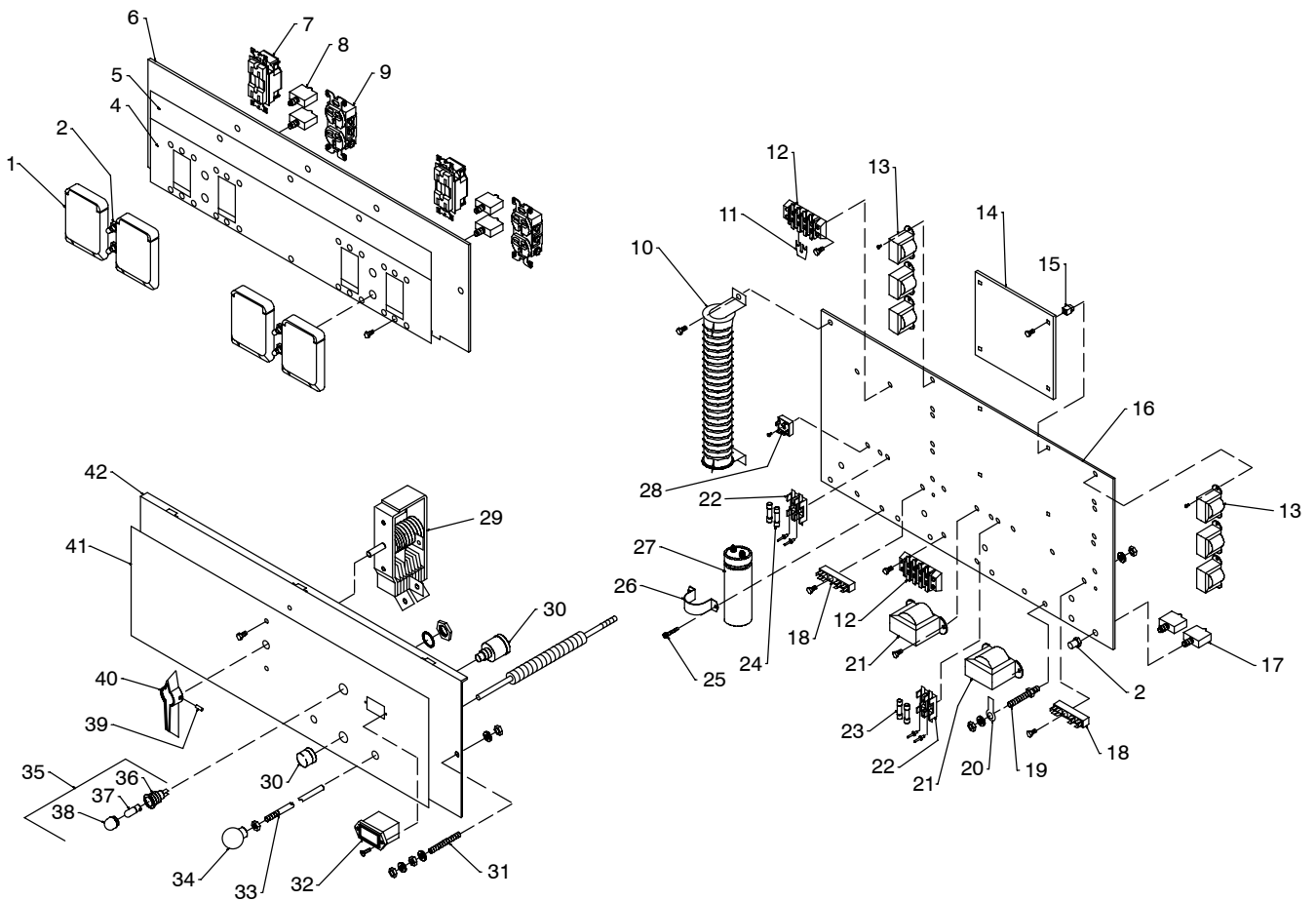

**Figure 12-2. Front Panel**

Item No.	Dia. Mkgs.	Part No.	Description	Quantity
.. 1		209056	COVER, receptacle w/gasket	4
.. 2		190 323	BOOT, circuit breaker	6
.. 3		Deleted		
.. 4			PLATE, ident control rating (order by model and serial number)	1
.. 5		190 375	NAMEPLATE	1
.. 6		216270	PANEL, aux power	1
..		192 334	HARNES, wiring aux power panel (consisting of)	1
.. 7	GFCI1,2	151 981	RECEPTACLE, str dx grd 2P3W 15/20A 125V GFCI	2
.. 8	CB1-4	093 996	CIRCUIT BREAKER, man reset 1P 20A 250VAC frict	4
.. 9	RC1, RC2	193 257	RECEPTACLE, str dx grd 2P3W 15/20A 250V	2
.. 10	R10	189 699	RESISTOR, WW tap 375W	1
.. 11		038 620	LINK, jumper term blk 30A	2
.. 12	TE1,2	038 621	BLOCK, term 30A 4 pole	2
.. 13	T5 - 10	210 636	TRANSFORMER, control 6VA 120VCT	6
.. 14	PC4	191 255	CIRCUIT CARD ASSEMBLY, field current regulator	1
.. 15		083 147	GROMMET, SCR NO 8/10 panel	4
.. 16		192 332	PANEL LAYOUT, mtg component	1
.. 17	CB7,8	139 266	CIRCUIT BREAKER, man reset	2
.. 18	1T,2T	190 210	BLOCK, term 5-3-3	2
.. 19		083 030	STUD, brs .250-20 x 1	1
.. 20		010 381	CONNECTOR, rectifier	1
.. 21	T1, T3	192 367	TRANSFORMER, control	2
.. 22		184 649	HOLDER, fuse mintr .250	2
.. 23	F3,4	*012 643	FUSE, mintr gl slo-blo 1A, 250V	2
.. 24	F1,2	*125 847	FUSE, mintr cer slo-blo 12A, 250V	2
.. 25		129 351	SCREW, 008-32x .50 hexwhd.34d stl pld slffmg tap-rw	2
.. 26		177 136	CLAMP, capacitor 1.375dia	1
.. 27	C1	087 110	CAPACITOR, elctlt 240	1
.. 28	SR1	035 704	RECTIFIER, integ bridge	1
..		195 702	HARNES, wiring componet panel (consisting of)	1
..		188 512	SEAL, wire univ 6P/S 3 row	3
..		187 651	SEAL, wire univ 9P/S 3 row	3
..	RC13,21	116 045	HOUSING, plugs and pins	2
..	PLG17	135 275	HOUSING, plugs and pins	1
..	RC19, PLG20	168 071	HOUSING, plugs and pins	1
.. 29	S2	192 292	SWITCH, paralleling	1
..		192 006	HARNES, engine (consisting of)	1
.. 30	PB1	046 433	SWITCH, PB MC NO SPST 35A	1
.. 31			STUD	1
.. 32	HM	145 247	METER, hour 12-24VDC	1
.. 33		205 744	ROD, engine shutoff assembly	1
.. 34		019 603	KNOB, ball	1
.. 35	PL1	188 266	LIGHT, ind red lens 13V (consisting of)	1
.. 36		082 788	HOLDER, light ind only	1
.. 37		048 155	BULB, incand min	1
.. 38		082 789	LENS, light ind red	1
.. 39		010 647	PIN, spring CS .156 x 1.250	1
.. 40		111 785	HANDLE, switch	1
.. 41			PLATE, ident control rating (order by model and serial number)	1
.. 42		192 316	PANEL, front control	1

+When ordering a component originally displaying a precautionary label, the label should also be ordered.

\*Recommended Spare Parts.

**To maintain the factory original performance of your equipment, use only Manufacturer's Suggested Replacement Parts. Model and serial number required when ordering parts from your local distributor.**

☞ Hardware is common and not available unless listed.

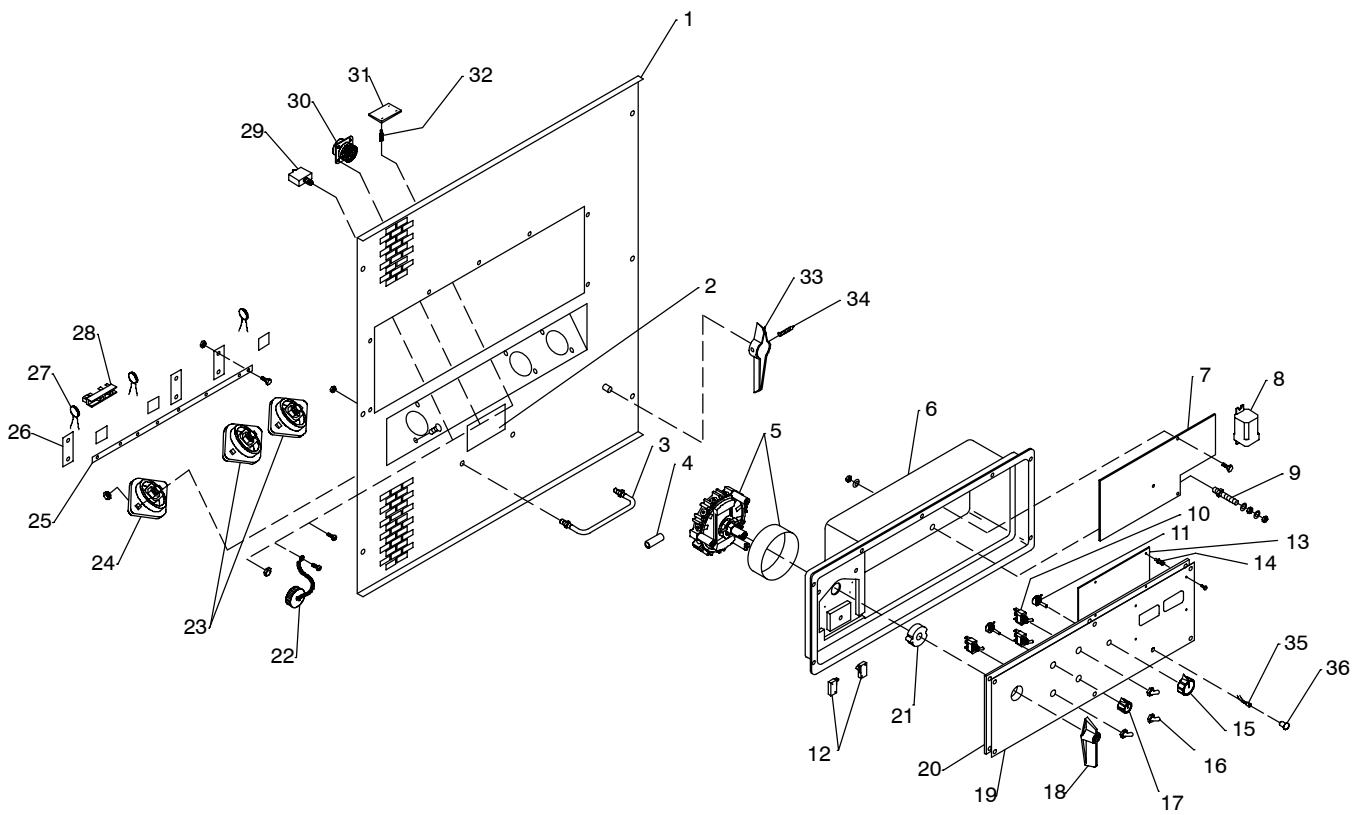

Figure 12-3. Side Control Panels – Welder B (Right) Side Shown

Item No.	Dia. Mkgs.	Part No.	Description	Quantity
----------	------------	----------	-------------	----------

**Figure 12-3. Side Control Panels (Figure 12-1 Item 57)**

.. 1		+192 330	.. PANEL, side output RH	1
		+192 325	.. PANEL, side output LH	1
.. 2		027 434	.. LABEL, welder will not start by applying power to terminals	2
.. 3		010 828	.. HANDLE	2
.. 4		086 074	.. TUBING, cop .540 ID x .123 wall x .562 – welder A (left) side only	1
.. 5	S1, S9	204 903	.. SWITCH, mode single w/ dust cover (consisting of)	2
		163 557	.. SWITCH, mode single	1
		202 881	.. COVER, dust	1
.. 6		193 337	.. ELECTRONICS BOX	2
.. 7	PC5	204 832	.. CIRCUIT CARD ASSEMBLY, welder B (right) side control	1
	PC1	204 835	.. CIRCUIT CARD ASSEMBLY, welder A (left) side control	1
		192 218	.. HARNESS, wiring control box welder B (right) (consisting of)	1
.. 8	CR3	000 770	.. RELAY, encl 24VDC 3PDT 10A/120VAC 11 pin	1
.. 9	GRD	185 011	.. STUD, primary board brs 10-32 x 1.592	1
.. 10	S8,10,11	011 609	.. SWITCH, tgl SPDT 15A 125VAC on-none-on	3
.. 11	R7,8	035 897	.. POTENTIOMETER, cp std slot 1t 2w 1k linear	2
.. 12	LS3, 4	089 645	.. SWITCH, lim 11A 125V	2
	PLG27	131 056	.. CONNECTOR, housing plug pins and sockets	1
		187 651	.. SEAL, wire univ 9P/S 3 row	1
	PLG20	168 071	.. CONNECTOR, housing plug pins and sockets	1
	PLG9,26	148 439	.. CONNECTOR, housing plug pins and sockets	2
	PLG12	152 249	.. CONNECTOR, housing plug pins and sockets	1
	PLG10	153 501	.. CONNECTOR, housing plug pins and sockets	1
	RC22	168 845	.. CONNECTOR, housing plug pins and sockets	1
	RC23	168846	.. CONNECTOR, housing plug pins and sockets	1
	PLG8	169 240	.. CONNECTOR, housing plug pins and sockets	1
		192 208	.. HARNESS, wiring control box welder A (left) (consisting of)	1
	CR2	000 770	.. RELAY, encl 24VDC 3PDT 10A/120VAC 11 pin	1
	GRD	185 011	.. STUD, primary board brs 10-32 x 1.592	1
	S3,6,7	011 609	.. SWITCH, tgl SPDT 15A 125VAC on-none-on	3
	R1,8	035 897	.. POTENTIOMETER, cp std slot 1t 2w 1k linear	2
	LS1,2	089 645	.. SWITCH, lim 11A 125V	2
	PLG18	131 056	.. CONNECTOR, housing plug pins and sockets	1
		187 651	.. SEAL, wire univ 9P/S 3 row	1
	PLG19	168 071	.. CONNECTOR, housing plug pins and sockets	1
	PLG4,11	148 439	.. CONNECTOR, housing plug pins and sockets	2
	PLG5	152 249	.. CONNECTOR, housing plug pins and sockets	1
	PLG10	153 501	.. CONNECTOR, housing plug pins and sockets	1
	RC6	168 845	.. CONNECTOR, housing plug pins and sockets	1
	RC7	168846	.. CONNECTOR, housing plug pins and sockets	1
	PLG3	169 240	.. CONNECTOR, housing plug pins and sockets	1
.. 13	PC2, PC6	178 130	.. CIRCUIT CARD ASSEMBLY, digital meter	2
.. 14		165 316	.. STAND-OFF, No. 6-32 x .875 lg .312 hex nyl	8
		136 343	.. SCREW, K50 x 20 soc hd trx stl pld slftpg	8
.. 15		097 924	.. KNOB, pointer 1.625dia x .250 ID	2
.. 16		021 385	.. BOOT, toggle switch lever	6
.. 17		097 922	.. KNOB, pointer .875dia x .250 ID	2
.. 18		148 956	.. HANDLE, switch	2
.. 19			.. NAMEPLATE (order by model and serial number)	2
.. 20		162 815	.. PANEL, front upper	2
.. 21		161 297	.. CAM, switch selector 2posn	2
.. 22		170 391	.. CONNECTOR, circ protective cap	1
.. 23		039 047	.. TERMINAL, pwr output red (consisting of)	4
		039 049	.. TERMINAL BOARD, red	1
		039 044	.. BUS BAR, term bd	1
		601 976	.. SCREW, 500-13 x 1.50 hexhd	1
		601 880	.. NUT, 500-13 x .75 hex .31H	1

Item No.	Dia. Mkgs.	Part No.	Description	Quantity
<b>Figure 12-3. Side Control Panels (Continued)</b>				
.. 24		039 046	.. TERMINAL, pwr output black (consisting of)	2
		039 045	.. TERMINAL BOARD, black	1
		039 044	.. BUS BAR, term bd	1
		601 976	.. SCREW, 500-13 x 1.50 hexhd	1
		601 880	.. NUT, 500-13 x .75 hex .31H	1
.. 25		192 494	.. BUS BAR, connecting	2
.. 26		192 493	.. STAND-OFF, bus bar	6
.. 27	C2,4,5,21,22,23	136 736	.. CAPACITOR, cer disc .1uf 500VDC	6
		192 336	.. HARNESS, wiring unit welder B (right) (consisting of)	1
.. 28	4T	190 210	.. BLOCK, term 5-3-3	1
.. 29	CB6	139 266	.. CIRCUIT BREAKER, man reset	1
.. 30	RC9	134 735	.. CONNECTOR, circ MS/CPC 14skt	1
.. 31	PC7	181 261	.. CIRCUIT CARD ASSEMBLY, filter	1
	PLG24	115 094	.. HOUSING, plug and sockets	1
	PLG22	168 847	.. HOUSING, plug pins and sockets	1
	PLG23	152 249	.. HOUSING, plug pins and sockets	1
	PLG21	135 556	.. HOUSING, plug pins and sockets	1
		188 512	.. SEAL, wire univ 6P/S 3 row	1
		192 337	.. HARNESS, wiring unit welder A (left) (consisting of)	1
	3T	190 210	.. BLOCK, term 5-3-3	1
	CB5	139 266	.. CIRCUIT BREAKER, man reset	1
	RC8	134 735	.. CONNECTOR, circ MS/CPC 14skt	1
	PC3	181 261	.. CIRCUIT CARD ASSEMBLY, filter	1
	PLG14	115 094	.. HOUSING, plug and sockets	1
	PLG6	168 847	.. HOUSING, plug pins and sockets	1
	PLG3	152 249	.. HOUSING, plug pins and sockets	1
	PLG13	135 556	.. HOUSING, plug pins and sockets	1
		188 512	.. SEAL, wire univ 6P/S 3 row	1
.. 32		165 316	.. STAND-OFF, No. 6-32 x .875 lg .312 hex nyl	6
		145 217	.. SCREW, K40 x 12 pan hd phl stl pld slftpg	6
.. 33		◆059 773	.. HANDLE, switch	2
.. 34		◆010 647	.. PIN, spring	2
		◆091 067	.. SWITCH, polarity	2
		◆168 077	.. CONNECTOR, tw lk insul fem (Dinse-type) to output stud	6
		◆199 123	.. LABEL, component identification master polarity	1
		◆199 124	.. LABEL, component identification slave polarity	1
.. 35	PL2, PL3	159 522	.. LED, yellow 2.1v 20 ma 45.0 mcd panel mtg .250 hole	2
.. 36		159 036	.. LENS, led clear panel mtg	2

+When ordering a component originally displaying a precautionary label, the label should also be ordered.

\*Recommended Spare Parts.

◆OPTIONAL

**To maintain the factory original performance of your equipment, use only Manufacturer's Suggested Replacement Parts. Model and serial number required when ordering parts from your local distributor.**

☞ Hardware is common and not available unless listed.

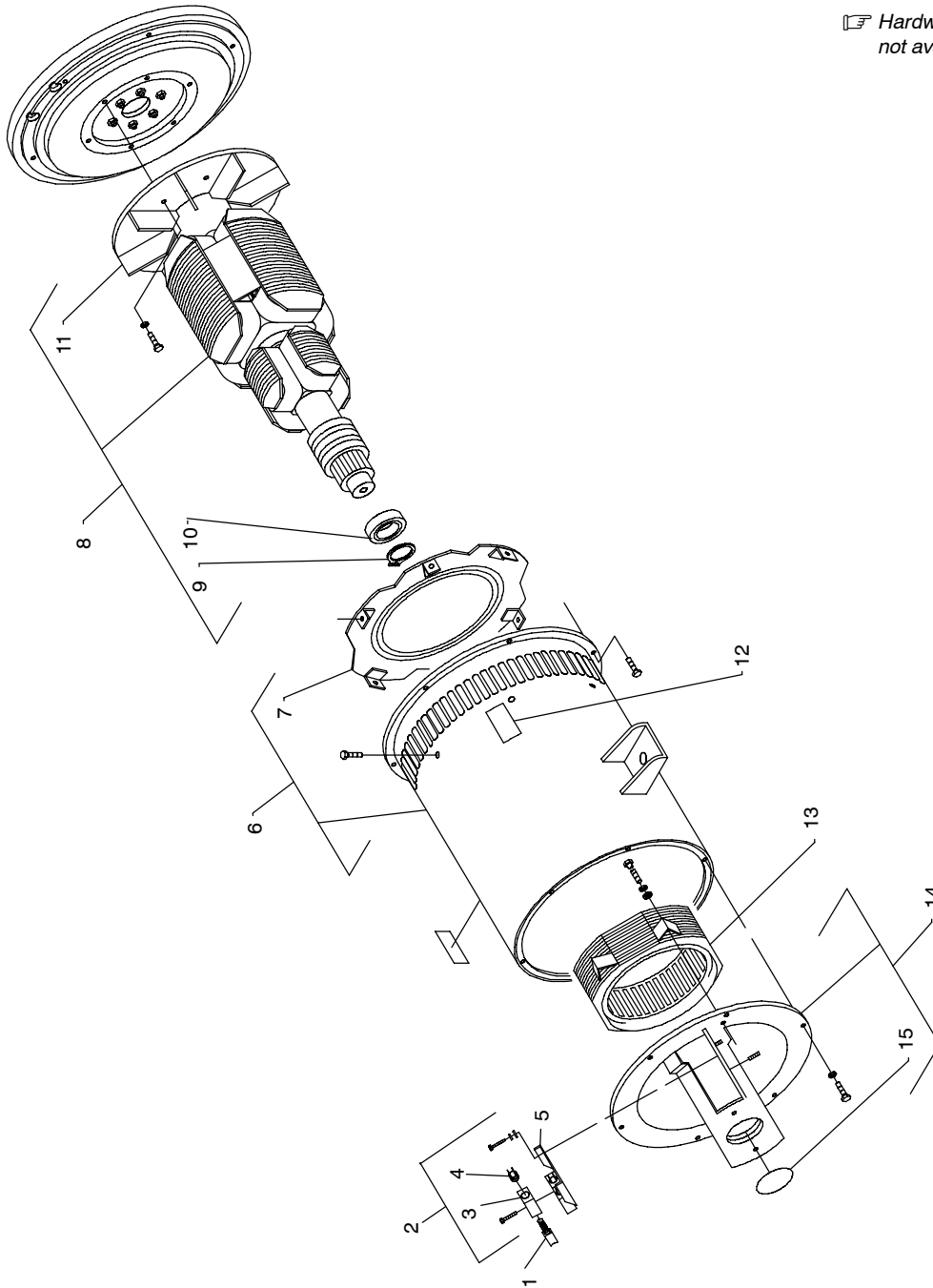

**Figure 12-4. Generator**

Ref. 048 456-E

Item No.	Dia. Mkgs.	Part No.	Description	Quantity
----------	------------	----------	-------------	----------

**Figure 12-4. Generator (Figure 12-1 Item 78)**

.. 1 .....	*151 299	.. BRUSH, contact elect clrg .375 x .750 .....	3
.. 2 .....	188 387	.. BRUSHHOLDER/BRACKET ASSEMBLY, (consisting of) .....	1
.. 3 .....	600 270	.. HOLDER, brush .....	3
.. 4 .....	152 044	.. CAP, holder brush .....	3
.. 5 .....	173 066	.. BRACKET, mtg brushholder .....	1
.. 6 .....	+205 600	.. STATOR, generator (consisting of) .....	1
.. 7 .....	039 207	.. BAFFLE, air generator .....	1
.. 8 .....	192 286	.. ROTOR, generator (consisting of) .....	1
.. 9 .....	024 617	.. RING, retaining external .....	1
.. 10 .....	053 390	.. BEARING, ball .....	1
.. 11 .....	083 748	.. FAN, rotor .....	1
.. 12 .....	225 120	.. LABEL, warning moving parts can cause injury .....	2

Item No.	Dia. Mkgs.	Part No.	Description	Quantity
----------	------------	----------	-------------	----------

**Figure 12-4. Generator (Continued)**

.. 13	195 704	..	STATOR, exciter aux pwr 120/240	1
.. 14	173 068	..	ENDBELL, generator (consisting of)	1
.. 15	143 220	....	O-RING 2.859ID x .139CS	1

+When ordering a component originally displaying a precautionary label, the label should also be ordered.

\*Recommended Spare Parts.

**To maintain the factory original performance of your equipment, use only Manufacturer's Suggested Replacement Parts. Model and serial number required when ordering parts from your local distributor.**

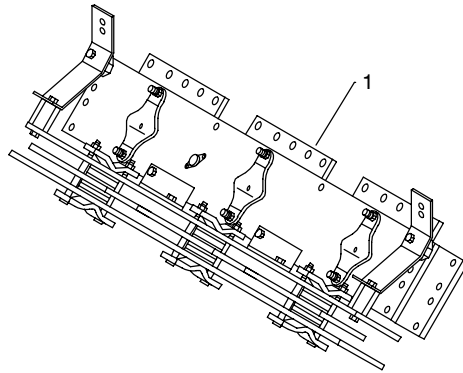

 Hardware is common and not available unless listed.

802 319

**Figure 12-5. Rectifier Assembly**

Item No.	Dia. Mkgs.	Part No.	Description	Quantity
----------	------------	----------	-------------	----------

**Figure 12-5. Rectifier (Figure 12-1 Item 25)**

.. 1	205 613	..	RECTIFIER ASSEMBLY	1
.....	203 001	..	RECTIFIER, Si Diode (One Side Service kit W/Varnish Coating)	1
.....	PLG1, PLG2 . 158 720	..	CONNECTOR & SOCKETS	1

**To maintain the factory original performance of your equipment, use only Manufacturer's Suggested Replacement Parts. Model and serial number required when ordering parts from your local distributor.**







# TRUE BLUE<sup>®</sup>

## WARRANTY

Effective January 1, 2005

(Equipment with a serial number preface of "LF" or newer)

This limited warranty supersedes all previous Miller warranties and is exclusive with no other guarantees or warranties expressed or implied.

### Warranty Questions?

Call  
1-800-4-A-MILLER  
for your local  
Miller distributor.

Your distributor also gives  
you ...

#### Service

You always get the fast,  
reliable response you  
need. Most replacement  
parts can be in your  
hands in 24 hours.

#### Support

Need fast answers to the  
tough welding questions?  
Contact your distributor.  
The expertise of the  
distributor and Miller is  
there to help you, every  
step of the way.

**LIMITED WARRANTY** - Subject to the terms and conditions below, Miller Electric Mfg. Co., Appleton, Wisconsin, warrants to its original retail purchaser that new Miller equipment sold after the effective date of this limited warranty is free of defects in material and workmanship at the time it is shipped by Miller. THIS WARRANTY IS EXPRESSLY IN LIEU OF ALL OTHER WARRANTIES, EXPRESS OR IMPLIED, INCLUDING THE WARRANTIES OF MERCHANTABILITY AND FITNESS.

Within the warranty periods listed below, Miller will repair or replace any warranted parts or components that fail due to such defects in material or workmanship. Miller must be notified in writing within thirty (30) days of such defect or failure, at which time Miller will provide instructions on the warranty claim procedures to be followed.

Miller shall honor warranty claims on warranted equipment listed below in the event of such a failure within the warranty time periods. All warranty time periods start on the date that the equipment was delivered to the original retail purchaser, or one year after the equipment is sent to a North American distributor or eighteen months after the equipment is sent to an International distributor.

- 5 Years Parts — 3 Years Labor
  - \* Original main power rectifiers
  - \* Inverters (input and output rectifiers only)
- 3 Years — Parts and Labor
  - \* Transformer/Rectifier Power Sources
  - \* Plasma Arc Cutting Power Sources
  - \* Semi-Automatic and Automatic Wire Feeders
  - \* Inverter Power Sources (Unless Otherwise Stated)
  - \* Water Coolant Systems (Integrated)
  - \* Intelligig
  - \* Maxstar 150
  - \* Engine Driven Welding Generators  
**(NOTE: Engines are warranted separately by the engine manufacturer.)**
- 1 Year — Parts and Labor Unless Specified
  - \* DS-2 Wire Feeder
  - \* Motor Driven Guns (w/exception of Spoolmate Spoolguns)
  - \* Process Controllers
  - \* Positioners and Controllers
  - \* Automatic Motion Devices
  - \* RFCS Foot Controls
  - \* Induction Heating Power Sources and Coolers
  - \* Water Coolant Systems (Non-Integrated)
  - \* Flowgauge and Flowmeter Regulators (No Labor)
  - \* HF Units
  - \* Grids
  - \* Maxstar 85, 140
  - \* Spot Welders
  - \* Load Banks
  - \* Arc Stud Power Sources & Arc Stud Guns
  - \* Racks
  - \* Running Gear/Trailers
  - \* Plasma Cutting Torches (except APT & SAF Models)
  - \* Field Options  
**(NOTE: Field options are covered under True Blue<sup>®</sup> for the remaining warranty period of the product they are installed in, or for a minimum of one year — whichever is greater.)**
- 6 Months — Batteries
- 90 Days — Parts
  - \* MIG Guns/TIG Torches

- \* Induction Heating Coils and Blankets
- \* APT & SAF Model Plasma Cutting Torches
- \* Remote Controls
- \* Accessory Kits
- \* Replacement Parts (No labor)
- \* Spoolmate Spoolguns
- \* Canvas Covers

Miller's True Blue<sup>®</sup> Limited Warranty shall not apply to:

- Consumable components; such as contact tips, cutting nozzles, contactors, brushes, slip rings, relays or parts that fail due to normal wear. (Exception: brushes, slip rings, and relays are covered on Bobcat, Trailblazer, and Legend models.)**
- Items furnished by Miller, but manufactured by others, such as engines or trade accessories. These items are covered by the manufacturer's warranty, if any.
- Equipment that has been modified by any party other than Miller, or equipment that has been improperly installed, improperly operated or misused based upon industry standards, or equipment which has not had reasonable and necessary maintenance, or equipment which has been used for operation outside of the specifications for the equipment.

MILLER PRODUCTS ARE INTENDED FOR PURCHASE AND USE BY COMMERCIAL/INDUSTRIAL USERS AND PERSONS TRAINED AND EXPERIENCED IN THE USE AND MAINTENANCE OF WELDING EQUIPMENT.

In the event of a warranty claim covered by this warranty, the exclusive remedies shall be, at Miller's option: (1) repair; or (2) replacement; or, where authorized in writing by Miller in appropriate cases, (3) the reasonable cost of repair or replacement at an authorized Miller service station; or (4) payment of or credit for the purchase price (less reasonable depreciation based upon actual use) upon return of the goods at customer's risk and expense. Miller's option of repair or replacement will be F.O.B., Factory at Appleton, Wisconsin, or F.O.B. at a Miller authorized service facility as determined by Miller. Therefore no compensation or reimbursement for transportation costs of any kind will be allowed.

TO THE EXTENT PERMITTED BY LAW, THE REMEDIES PROVIDED HEREIN ARE THE SOLE AND EXCLUSIVE REMEDIES. IN NO EVENT SHALL MILLER BE LIABLE FOR DIRECT, INDIRECT, SPECIAL, INCIDENTAL OR CONSEQUENTIAL DAMAGES (INCLUDING LOSS OF PROFIT), WHETHER BASED ON CONTRACT, TORT OR ANY OTHER LEGAL THEORY.

ANY EXPRESS WARRANTY NOT PROVIDED HEREIN AND ANY IMPLIED WARRANTY, GUARANTY OR REPRESENTATION AS TO PERFORMANCE, AND ANY REMEDY FOR BREACH OF CONTRACT TORT OR ANY OTHER LEGAL THEORY WHICH, BUT FOR THIS PROVISION, MIGHT ARISE BY IMPLICATION, OPERATION OF LAW, CUSTOM OF TRADE OR COURSE OF DEALING, INCLUDING ANY IMPLIED WARRANTY OF MERCHANTABILITY OR FITNESS FOR PARTICULAR PURPOSE, WITH RESPECT TO ANY AND ALL EQUIPMENT FURNISHED BY MILLER IS EXCLUDED AND DISCLAIMED BY MILLER.

Some states in the U.S.A. do not allow limitations of how long an implied warranty lasts, or the exclusion of incidental, indirect, special or consequential damages, so the above limitation or exclusion may not apply to you. This warranty provides specific legal rights, and other rights may be available, but may vary from state to state.

In Canada, legislation in some provinces provides for certain additional warranties or remedies other than as stated herein, and to the extent that they may not be waived, the limitations and exclusions set out above may not apply. This Limited Warranty provides specific legal rights, and other rights may be available, but may vary from province to province.





# Owner's Record

Please complete and retain with your personal records.

Model Name	Serial/Style Number
Purchase Date	(Date which equipment was delivered to original customer.)
Distributor	
Address	
City	
State	Zip



## For Service

**Contact a DISTRIBUTOR or SERVICE AGENCY near you.**

Always provide Model Name and Serial/Style Number.

Contact your Distributor for:

- Welding Supplies and Consumables
  - Options and Accessories
  - Personal Safety Equipment
  - Service and Repair
  - Replacement Parts
  - Training (Schools, Videos, Books)
  - Technical Manuals (Servicing Information and Parts)
  - Circuit Diagrams
  - Welding Process Handbooks
- To locate a Distributor or Service Agency visit [www.millerwelds.com](http://www.millerwelds.com) or call 1-800-4-A-Miller

Contact the Delivering Carrier to:

- File a claim for loss or damage during shipment.
- For assistance in filing or settling claims, contact your distributor and/or equipment manufacturer's Transportation Department.

### Miller Electric Mfg. Co.

An Illinois Tool Works Company  
1635 West Spencer Street  
Appleton, WI 54914 USA

### International Headquarters—USA

USA Phone: 920-735-4505 Auto-Attended  
USA & Canada FAX: 920-735-4134  
International FAX: 920-735-4125

### European Headquarters – United Kingdom

Phone: 44 (0) 1204-593493  
FAX: 44 (0) 1204-598066

[www.MillerWelds.com](http://www.MillerWelds.com)

