



OM-945

194 047AA

2006-07

Processes



Stick (SMAW) Welding

Description



Engine Driven Welding Generator

Champion™ 10,000

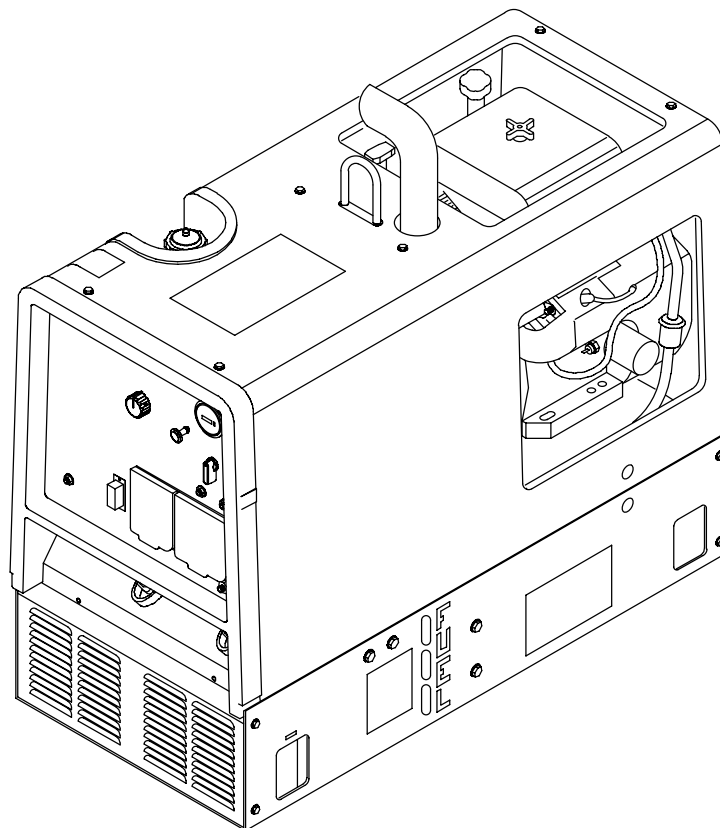

www.HobartWelders.com



OWNER'S MANUAL

From Hobart to You

Thank you and congratulations on choosing Hobart. Now you can get the job done and get it done right. We know you don't have time to do it any other way.

This Owner's Manual is designed to help you get the most out of your Hobart products. Please take time to read the Safety precautions. They will help you protect yourself against potential hazards on the worksite.



Hobart is registered to the ISO 9001:2000 Quality System Standard.

We've made installation and operation quick and easy. With Hobart you can count on years of reliable service with proper maintenance. And if for some reason the unit needs repair, there's a Troubleshooting section that will help you figure out what the problem is. The parts list will then help you to decide the exact part you may need to fix the problem. Warranty and service information for your particular model are also provided.

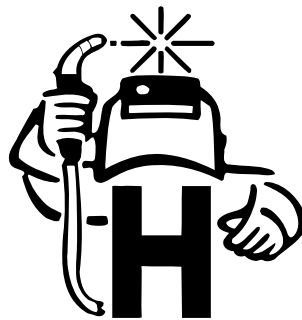

Hobart Welders manufactures a full line of welders and welding related equipment. For information on other quality Hobart products, contact your local Hobart distributor to receive the latest full line catalog or individual specification sheets. **To locate your nearest distributor or service agency call 1-877-Hobart1 or visit our website at www.HobartWelders.com.**

For Technical Help call 1-800-332-3281.

5/3/1 WARRANTY

Working as hard as you do – every power source from Hobart is backed by the best warranty in the business.

Protect Your Investment!



Register your product at:
HobartWelders.com

TABLE OF CONTENTS

SECTION 1 – SAFETY PRECAUTIONS – READ BEFORE USING	1
1-1. Symbol Usage	1
1-2. Arc Welding Hazards	1
1-3. Engine Hazards	2
1-4. Compressed Air Hazards	3
1-5. Additional Symbols For Installation, Operation, And Maintenance	3
1-6. California Proposition 65 Warnings	4
1-7. Principal Safety Standards	4
1-8. EMF Information	4
SECTION 2 – CONSIGNES DE SÉCURITÉ – LIRE AVANT UTILISATION	5
2-1. Signification des symboles	5
2-2. Dangers relatifs au soudage à l'arc	5
2-3. Dangers existant en relation avec le moteur	6
2-4. Dangers liés à l'air comprimé	7
2-5. Dangers supplémentaires en relation avec l'installation, le fonctionnement et la maintenance	7
2-6. Proposition californienne 65 Avertissements	8
2-7. Principales normes de sécurité	8
2-8. Information EMF	8
SECTION 3 – DEFINITIONS	9
SECTION 4 – SPECIFICATIONS	9
4-1. Weld, Power, and Engine Specifications	9
4-2. Dimensions, Weights, and Operating Angles	10
4-3. Generator Power Curve	10
4-4. Fuel Consumption (All Models)	11
4-5. Duty Cycle	11
4-6. Volt-Ampere Curves	12
SECTION 5 – INSTALLATION	13
5-1. Installing Welding Generator	13
5-2. Engine Prestart Checks (Robin-Powered Units)	14
5-3. Engine Prestart Checks (Kohler-Powered Units)	14
5-4. Activating The Dry Charge Battery (If Applicable)	15
5-5. Connecting the Battery	15
5-6. Installing Exhaust Pipe	16
5-7. Weld Output Terminals	16
5-8. Connecting To Weld Output Terminals	17
5-9. Selecting Weld Cable Sizes*	17
SECTION 6 – OPERATING THE WELDING GENERATOR	18
6-1. Front Panel Controls	18
6-2. Cold Weather Engine Operation	19
6-3. Amperage Selection Table For Stick (SMAW) Electrodes	19
SECTION 7 – OPERATING AUXILIARY EQUIPMENT	20
7-1. Standard Receptacles	20
7-2. Optional Generator Power Receptacles	21
7-3. Wiring Instructions For Optional 240 Volt, Single-Phase Plug (NEMA 14-50P)	22
SECTION 8 – MAINTENANCE (ROBIN-POWERED UNITS)	23
8-1. Routine Maintenance (Robin-Powered Units)	23
8-2. Maintenance Label (Robin-Powered Units)	24
8-3. Servicing Air Cleaner (Robin-Powered Units)	25
8-4. Overload Protection (Robin-Powered Units)	26
8-5. Servicing Optional Spark Arrestor (Robin-Powered Units)	26
8-6. Changing Engine Oil, Oil Filter, and Fuel Filter (Robin-Powered Units)	27
8-7. Adjusting Engine Speed (Robin-Powered Units)	28

TABLE OF CONTENTS

SECTION 9 – MAINTENANCE – (KOHLER-POWERED UNITS)	29
9-1. Routine Maintenance (Kohler-Powered Units)	29
9-2. Maintenance Label (Kohler-Powered Units)	30
9-3. Servicing Air Cleaner (Kohler-Powered Units)	31
9-4. Overload Protection (Kohler-Powered Units)	32
9-5. Servicing Optional Spark Arrestor (Kohler-Powered Units)	32
9-6. Changing Engine Oil, Oil Filter, and Fuel Filter (Kohler-Powered Units)	33
9-7. Adjusting Engine Speed (Kohler-Powered Units)	34
SECTION 10 – TROUBLESHOOTING	35
SECTION 11 – ELECTRICAL DIAGRAM	38
SECTION 12 – GENERATOR POWER GUIDELINES	39
SECTION 13 – STICK WELDING (SMAW) GUIDELINES	46
SECTION 14 – PARTS LIST	54
OPTIONS AND ACCESSORIES	
WARRANTY	

SECTION 1 – SAFETY PRECAUTIONS – READ BEFORE USING

rom_nd_3/05

▲ **Warning: Protect yourself and others from injury — read and follow these precautions.**

1-1. Symbol Usage



Means Warning! Watch Out! There are possible hazards with this procedure! The possible hazards are shown in the adjoining symbols.

▲ **Marks a special safety message.**

☞ Means “Note”; not safety related.



This group of symbols means Warning! Watch Out! possible ELECTRIC SHOCK, MOVING PARTS, and HOT PARTS hazards. Consult symbols and related instructions below for necessary actions to avoid the hazards.

1-2. Arc Welding Hazards

▲ **The symbols shown below are used throughout this manual to call attention to and identify possible hazards. When you see the symbol, watch out, and follow the related instructions to avoid the hazard. The safety information given below is only a summary of the more complete safety information found in the Safety Standards listed in Section 1-7. Read and follow all Safety Standards.**

▲ **Only qualified persons should install, operate, maintain, and repair this unit.**

▲ **During operation, keep everybody, especially children, away.**



ELECTRIC SHOCK can kill.

Touching live electrical parts can cause fatal shocks or severe burns. The electrode and work circuit is electrically live whenever the output is on. The input power circuit and machine internal circuits are also live when power is on. In semiautomatic or automatic wire welding, the wire, wire reel, drive roll housing, and all metal parts touching the welding wire are electrically live. Incorrectly installed or improperly grounded equipment is a hazard.

- Do not touch live electrical parts.
- Wear dry, hole-free insulating gloves and body protection.
- Insulate yourself from work and ground using dry insulating mats or covers big enough to prevent any physical contact with the work or ground.
- Do not use AC output in damp areas, if movement is confined, or if there is a danger of falling.
- Use AC output ONLY if required for the welding process.
- If AC output is required, use remote output control if present on unit.
- Additional safety precautions are required when any of the following electrically hazardous conditions are present: in damp locations or while wearing wet clothing; on metal structures such as floors, gratings, or scaffolds; when in cramped positions such as sitting, kneeling, or lying; or when there is a high risk of unavoidable or accidental contact with the workpiece or ground. For these conditions, use the following equipment in order presented: 1) a semiautomatic DC constant voltage (wire) welder, 2) a DC manual (stick) welder, or 3) an AC welder with reduced open-circuit voltage. In most situations, use of a DC, constant voltage wire welder is recommended. And, do not work alone!
- Disconnect input power or stop engine before installing or servicing this equipment. Lockout/tagout input power according to OSHA 29 CFR 1910.147 (see Safety Standards).
- Properly install and ground this equipment according to its Owner's Manual and national, state, and local codes.
- Always verify the supply ground — check and be sure that input power cord ground wire is properly connected to ground terminal in disconnect box or that cord plug is connected to a properly grounded receptacle outlet.
- When making input connections, attach proper grounding conductor first — double-check connections.
- Frequently inspect input power cord for damage or bare wiring — replace cord immediately if damaged — bare wiring can kill.
- Turn off all equipment when not in use.
- Do not use worn, damaged, undersized, or poorly spliced cables.
- Do not drape cables over your body.
- If earth grounding of the workpiece is required, ground it directly with a separate cable.
- Do not touch electrode if you are in contact with the work, ground, or another electrode from a different machine.
- Use only well-maintained equipment. Repair or replace damaged parts at once. Maintain unit according to manual.

- Do not touch electrode holders connected to two welding machines at the same time since double open-circuit voltage will be present.
- Wear a safety harness if working above floor level.
- Keep all panels and covers securely in place.
- Clamp work cable with good metal-to-metal contact to workpiece or worktable as near the weld as practical.
- Insulate work clamp when not connected to workpiece to prevent contact with any metal object.
- Do not connect more than one electrode or work cable to any single weld output terminal.

SIGNIFICANT DC VOLTAGE exists in inverters after stopping engine.

- Stop engine on inverter and discharge input capacitors according to instructions in Maintenance Section before touching any parts.

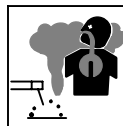

FUMES AND GASES can be hazardous.

Welding produces fumes and gases. Breathing these fumes and gases can be hazardous to your health.

- Keep your head out of the fumes. Do not breathe the fumes.
- If inside, ventilate the area and/or use local forced ventilation at the arc to remove welding fumes and gases.
- If ventilation is poor, wear an approved air-supplied respirator.
- Read and understand the Material Safety Data Sheets (MSDSs) and the manufacturer's instructions for metals, consumables, coatings, cleaners, and degreasers.
- Work in a confined space only if it is well ventilated, or while wearing an air-supplied respirator. Always have a trained watchperson nearby. Welding fumes and gases can displace air and lower the oxygen level causing injury or death. Be sure the breathing air is safe.
- Do not weld in locations near degreasing, cleaning, or spraying operations. The heat and rays of the arc can react with vapors to form highly toxic and irritating gases.
- Do not weld on coated metals, such as galvanized, lead, or cadmium plated steel, unless the coating is removed from the weld area, the area is well ventilated, and while wearing an air-supplied respirator. The coatings and any metals containing these elements can give off toxic fumes if welded.



BUILDUP OF GAS can injure or kill.

- Shut off shielding gas supply when not in use.
- Always ventilate confined spaces or use approved air-supplied respirator.

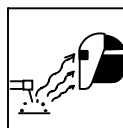

ARC RAYS can burn eyes and skin.

Arc rays from the welding process produce intense visible and invisible (ultraviolet and infrared) rays that can burn eyes and skin. Sparks fly off from the weld.

- Wear an approved welding helmet fitted with a proper shade of filter lenses to protect your face and eyes from arc rays and sparks when welding or watching (see ANSI Z49.1 and Z87.1 listed in Safety Standards).
- Wear approved safety glasses with side shields under your helmet.
- Use protective screens or barriers to protect others from flash, glare, and sparks; warn others not to watch the arc.
- Wear protective clothing made from durable, flame-resistant material (leather, heavy cotton, or wool) and foot protection.



WELDING can cause fire or explosion.

Welding on closed containers, such as tanks, drums, or pipes, can cause them to blow up. Sparks can fly off from the welding arc. The flying sparks, hot workpiece, and hot equipment can cause fires and burns. Accidental contact of electrode to metal objects can cause sparks, explosion, overheating, or fire. Check and be sure the area is safe before doing any welding.

- Remove all flammables within 35 ft (10.7 m) of the welding arc. If this is not possible, tightly cover them with approved covers.
- Do not weld where flying sparks can strike flammable material.
- Protect yourself and others from flying sparks and hot metal.
- Be alert that welding sparks and hot materials from welding can easily go through small cracks and openings to adjacent areas.
- Watch for fire, and keep a fire extinguisher nearby.
- Be aware that welding on a ceiling, floor, bulkhead, or partition can cause fire on the hidden side.
- Do not weld on closed containers such as tanks, drums, or pipes, unless they are properly prepared according to AWS F4.1 (see Safety Standards).
- Connect work cable to the work as close to the welding area as practical to prevent welding current from traveling long, possibly unknown paths and causing electric shock, sparks, and fire hazards.
- Do not use welder to thaw frozen pipes.
- Remove stick electrode from holder or cut off welding wire at contact tip when not in use.
- Wear oil-free protective garments such as leather gloves, heavy shirt, cuffless trousers, high shoes, and a cap.
- Remove any combustibles, such as a butane lighter or matches, from your person before doing any welding.
- Follow requirements in OSHA 1910.252 (a) (2) (iv) and NFPA 51B for hot work and have a fire watcher and extinguisher nearby.

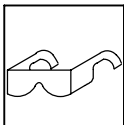

FLYING METAL can injure eyes.

- Welding, chipping, wire brushing, and grinding cause sparks and flying metal. As welds cool, they can throw off slag.
- Wear approved safety glasses with side shields even under your welding helmet.

1-3. Engine Hazards



BATTERY EXPLOSION can BLIND.

- Always wear a face shield, rubber gloves, and protective clothing when working on a battery.
- Stop engine before disconnecting or connecting battery cables or servicing battery.
- Do not allow tools to cause sparks when working on a battery.
- Do not use welder to charge batteries or jump start vehicles.
- Observe correct polarity (+ and -) on batteries.
- Disconnect negative (-) cable first and connect it last.



FUEL can cause fire or explosion.

- Stop engine and let it cool off before checking or adding fuel.
- Do not add fuel while smoking or if unit is near any sparks or open flames.
- Do not overfill tank — allow room for fuel to expand.
- Do not spill fuel. If fuel is spilled, clean up before starting engine.
- Dispose of rags in a fireproof container.
- Always keep nozzle in contact with tank when fueling.



HOT PARTS can cause severe burns.

- Do not touch hot parts bare handed.
- Allow cooling period before working on equipment.
- To handle hot parts, use proper tools and/or wear heavy, insulated welding gloves and clothing to prevent burns.



NOISE can damage hearing.

Noise from some processes or equipment can damage hearing.

- Wear approved ear protection if noise level is high.

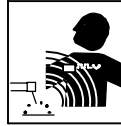

MAGNETIC FIELDS can affect pacemakers.

- Pacemaker wearers keep away.
- Wearers should consult their doctor before going near arc welding, gouging, or spot welding operations.



CYLINDERS can explode if damaged.

Shielding gas cylinders contain gas under high pressure. If damaged, a cylinder can explode. Since gas cylinders are normally part of the welding process, be sure to treat them carefully.

- Protect compressed gas cylinders from excessive heat, mechanical shocks, physical damage, slag, open flames, sparks, and arcs.
- Install cylinders in an upright position by securing to a stationary support or cylinder rack to prevent falling or tipping.
- Keep cylinders away from any welding or other electrical circuits.
- Never drape a welding torch over a gas cylinder.
- Never allow a welding electrode to touch any cylinder.
- Never weld on a pressurized cylinder — explosion will result.
- Use only correct shielding gas cylinders, regulators, hoses, and fittings designed for the specific application; maintain them and associated parts in good condition.
- Turn face away from valve outlet when opening cylinder valve.
- Keep protective cap in place over valve except when cylinder is in use or connected for use.
- Use the right equipment, correct procedures, and sufficient number of persons to lift and move cylinders.
- Read and follow instructions on compressed gas cylinders, associated equipment, and Compressed Gas Association (CGA) publication P-1 listed in Safety Standards.



MOVING PARTS can cause injury.

- Keep away from fans, belts, and rotors.
- Keep all doors, panels, covers, and guards closed and securely in place.
- Stop engine before installing or connecting unit.
- Have only qualified people remove doors, panels, covers, or guards for maintenance and troubleshooting as necessary.
- To prevent accidental starting during servicing, disconnect negative (-) battery cable from battery.
- Keep hands, hair, loose clothing, and tools away from moving parts.
- Reinstall doors, panels, covers, or guards when servicing is finished and before starting engine.
- Before working on generator, remove spark plugs or injectors to keep engine from kicking back or starting.
- Block flywheel so that it will not turn while working on generator components.



HOT PARTS can cause severe burns.

- Do not touch hot engine parts.
- Allow cooling period before maintaining.
- Wear protective gloves and clothing when working on a hot engine.



STEAM AND HOT COOLANT can burn.

- If possible, check coolant level when engine is cold to avoid scalding.
- Always check coolant level at overflow tank, if present on unit, instead of radiator (unless told otherwise in maintenance section or engine manual).
- If the engine is warm, checking is needed, and there is no overflow tank, follow the next two statements.
- Wear safety glasses and gloves and put a rag over radiator cap.
- Turn cap slightly and let pressure escape slowly before completely removing cap.



ENGINE EXHAUST GASES can kill.

- Use equipment outside in open, well-ventilated areas.
- If used in a closed area, vent engine exhaust outside and away from any building air intakes.

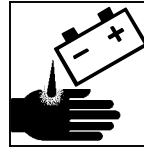

BATTERY ACID can BURN SKIN and EYES.

- Do not tip battery.
- Replace damaged battery.
- Flush eyes and skin immediately with water.

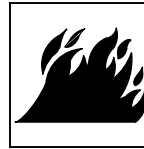

ENGINE HEAT can cause fire.

- Do not locate unit on, over, or near combustible surfaces or flammables.
- Keep exhaust and exhaust pipes way from flammables.



EXHAUST SPARKS can cause fire.

- Do not let engine exhaust sparks cause fire.
- Use approved engine exhaust spark arrester in required areas — see applicable codes.

1-4. Compressed Air Hazards



BREATHING COMPRESSED AIR can cause serious injury or death.

- Do not use compressed air for breathing.
- Use only for cutting, gouging, and tools.

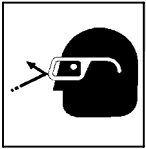

COMPRESSED AIR can cause injury.

- Wear approved safety goggles.
- Do not direct air stream toward self or others.



TRAPPED AIR PRESSURE AND WHIPPING HOSES can cause injury.

- Release air pressure from tools and system before servicing, adding or changing attachments, or opening compressor oil drain or oil fill cap.



HOT METAL from air arc cutting and gouging can cause fire or explosion.

- Do not cut or gouge near flammables.
- Watch for fire; keep extinguisher nearby.



HOT PARTS can cause burns and injury.

- Do not touch hot compressor or air system parts.
- Let system cool down before touching or servicing.

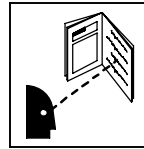

READ INSTRUCTIONS.

- Read Owner's Manual before using or servicing unit.
- Stop engine and release air pressure before servicing.
- Use only genuine Miller/Hobart replacement parts.

1-5. Additional Symbols For Installation, Operation, And Maintenance



FALLING UNIT can cause injury.

- Use lifting eye to lift unit and properly installed accessories only. Do not exceed maximum lift eye weight rating (see Specifications).
- Lift and support unit only with proper equipment and correct procedures.
- If using lift forks to move unit, be sure forks are long enough to extend beyond opposite side of unit.

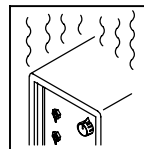

OVERUSE can cause OVERHEATING.

- Allow cooling period; follow rated duty cycle.
- Reduce current or reduce duty cycle before starting to weld again.
- Do not block or filter airflow to unit.

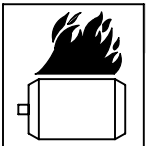

OVERHEATING can damage motors.

- Turn off or unplug equipment before starting or stopping engine.
- Do not let low voltage and frequency caused by low engine speed damage electric motors.
- Do not connect 50 or 60 Hertz motors to the 100 Hertz receptacle where applicable.

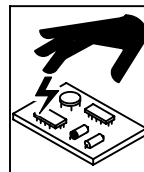

STATIC (ESD) can damage PC boards.

- Put on grounded wrist strap BEFORE handling boards or parts.
- Use proper static-proof bags and boxes to store, move, or ship PC boards.

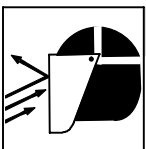

FLYING SPARKS can cause injury.

- Wear a face shield to protect eyes and face.
- Shape tungsten electrode only on grinder with proper guards in a safe location wearing proper face, hand, and body protection.
- Sparks can cause fires — keep flammables away.

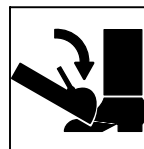

TILTING OF TRAILER can cause injury.

- Use tongue jack or blocks to support weight.
- Properly install welding generator onto trailer according to instructions supplied with trailer.

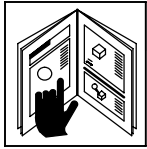

READ INSTRUCTIONS.

- Use only genuine MILLER/Hobart replacement parts.
- Perform engine and air compressor (if applicable) maintenance and service according to this manual and the engine/air compressor (if applicable) manuals.

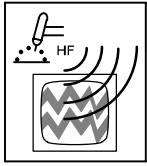

H.F. RADIATION can cause interference.

- High-frequency (H.F.) can interfere with radio navigation, safety services, computers, and communications equipment.
- Have only qualified persons familiar with electronic equipment perform this installation.
- The user is responsible for having a qualified electrician promptly correct any interference problem resulting from the installation.
- If notified by the FCC about interference, stop using the equipment at once.
- Have the installation regularly checked and maintained.
- Keep high-frequency source doors and panels tightly shut, keep spark gaps at correct setting, and use grounding and shielding to minimize the possibility of interference.

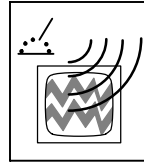

ARC WELDING can cause interference.

- Electromagnetic energy can interfere with sensitive electronic equipment such as microprocessors, computers, and computer-driven equipment such as robots.
- Be sure all equipment in the welding area is electromagnetically compatible.
- To reduce possible interference, keep weld cables as short as possible, close together, and down low, such as on the floor.
- Locate welding operation 100 meters from any sensitive electronic equipment.
- Be sure this welding machine is installed and grounded according to this manual.
- If interference still occurs, the user must take extra measures such as moving the welding machine, using shielded cables, using line filters, or shielding the work area.

1-6. California Proposition 65 Warnings

- ▲ **Welding or cutting equipment produces fumes or gases which contain chemicals known to the State of California to cause birth defects and, in some cases, cancer. (California Health & Safety Code Section 25249.5 et seq.)**
- ▲ **Battery posts, terminals and related accessories contain lead and lead compounds, chemicals known to the State of California to cause cancer and birth defects or other reproductive harm. Wash hands after handling.**

For Gasoline Engines:

- ▲ **Engine exhaust contains chemicals known to the State of California to cause cancer, birth defects, or other reproductive harm.**

For Diesel Engines:

- ▲ **Diesel engine exhaust and some of its constituents are known to the State of California to cause cancer, birth defects, and other reproductive harm.**

1-7. Principal Safety Standards

Safety in Welding, Cutting, and Allied Processes, ANSI Standard Z49.1, from Global Engineering Documents (phone: 1-877-413-5184, website: www.global.ihs.com).

Recommended Safe Practices for the Preparation for Welding and Cutting of Containers and Piping, American Welding Society Standard AWS F4.1, from Global Engineering Documents (phone: 1-877-413-5184, website: www.global.ihs.com).

National Electrical Code, NFPA Standard 70, from National Fire Protection Association, P.O. Box 9101, 1 Battery March Park, Quincy, MA 02269-9101 (phone: 617-770-3000, website: www.nfpa.org and www.sparky.org).

Safe Handling of Compressed Gases in Cylinders, CGA Pamphlet P-1, from Compressed Gas Association, 1735 Jefferson Davis Highway, Suite 1004, Arlington, VA 22202-4102 (phone: 703-412-0900, website: www.cganet.com).

Code for Safety in Welding and Cutting, CSA Standard W117.2, from Canadian Standards Association, Standards Sales, 178 Rexdale Bou-

levard, Rexdale, Ontario, Canada M9W 1R3 (phone: 800-463-6727 or in Toronto 416-747-4044, website: www.csa-international.org).

Practice For Occupational And Educational Eye And Face Protection, ANSI Standard Z87.1, from American National Standards Institute, 11 West 42nd Street, New York, NY 10036-8002 (phone: 212-642-4900, website: www.ansi.org).

Standard for Fire Prevention During Welding, Cutting, and Other Hot Work, NFPA Standard 51B, from National Fire Protection Association, P.O. Box 9101, 1 Battery March Park, Quincy, MA 02269-9101 (phone: 617-770-3000, website: www.nfpa.org).

OSHA, Occupational Safety and Health Standards for General Industry, Title 29, Code of Federal Regulations (CFR), Part 1910, Subpart Q, and Part 1926, Subpart J, from U.S. Government Printing Office, Superintendent of Documents, P.O. Box 371954, Pittsburgh, PA 15250 (there are 10 Regional Offices—phone for Region 5, Chicago, is 312-353-2220, website: www.osha.gov).

1-8. EMF Information

Considerations About Welding And The Effects Of Low Frequency Electric And Magnetic Fields

Welding current, as it flows through welding cables, will cause electromagnetic fields. There has been and still is some concern about such fields. However, after examining more than 500 studies spanning 17 years of research, a special blue ribbon committee of the National Research Council concluded that: "The body of evidence, in the committee's judgment, has not demonstrated that exposure to power-frequency electric and magnetic fields is a human-health hazard." However, studies are still going forth and evidence continues to be examined. Until the final conclusions of the research are reached, you may wish to minimize your exposure to electromagnetic fields when welding or cutting.

To reduce magnetic fields in the workplace, use the following procedures:

1. Keep cables close together by twisting or taping them.
2. Arrange cables to one side and away from the operator.
3. Do not coil or drape cables around your body.
4. Keep welding power source and cables as far away from operator as practical.
5. Connect work clamp to workpiece as close to the weld as possible.

About Pacemakers:

Pacemaker wearers consult your doctor before welding or going near welding operations. If cleared by your doctor, then following the above procedures is recommended.

SECTION 2 – CONSIGNES DE SÉCURITÉ – LIRE AVANT UTILISATION

rom_fre 3/05

▲ **Avertissement: Protégez vous et les autres des blessures – lisez et suivez ces précautions.**

2-1. Signification des symboles



Signifie Mise en garde ! Soyez vigilant ! Cette procédure présente des risques de danger ! Ceux-ci sont identifiés par des symboles adjacents aux directives.

▲ **Identifie un message de sécurité particulier.**

☞ Signifie NOTA ; n'est pas relatif à la sécurité.



Ce groupe de symboles signifie Mise en garde ! Soyez vigilant ! Il y a des risques de danger reliés aux CHOCS ÉLEC-

TRIFIQUES, aux PIÈCES EN MOUVEMENT et aux PIÈCES CHAUDES. Reportez-vous aux symboles et aux directives ci-dessous afin de connaître les mesures à prendre pour éviter tout danger.

2-2. Dangers relatifs au soudage à l'arc

▲ **Les symboles présentés ci-après sont utilisés tout au long du présent manuel pour attirer votre attention et identifier les risques de danger. Lorsque vous voyez un symbole, soyez vigilant et suivez les directives mentionnées afin d'éviter tout danger. Les consignes de sécurité présentées ci-après ne font que résumer l'information contenue dans les normes de sécurité énumérées à la section 2-7. Veuillez lire et respecter toutes ces normes de sécurité.**

▲ **L'installation, l'utilisation, l'entretien et les réparations ne doivent être confiés qu'à des personnes qualifiées.**

▲ **Au cours de l'utilisation, tenir toute personne à l'écart et plus particulièrement les enfants.**



UN CHOC ÉLECTRIQUE peut tuer.

Un simple contact avec des pièces électriques peut provoquer une électrocution ou des blessures graves. L'électrode et le circuit de soudage sont sous tension dès que l'appareil est sur ON. Le circuit d'entrée et les circuits internes de l'appareil sont également sous tension à ce moment-là. En soudage semi-automatique ou automatique, le fil, le dévidoir, le logement des galets d'entraînement et les pièces métalliques en contact avec le fil de soudage sont sous tension. Des matériels mal installés ou mal mis à la terre présentent un danger.

- Ne jamais toucher les pièces électriques sous tension.
- Porter des gants et des vêtements de protection secs ne comportant pas de trous.
- S'isoler de la pièce et de la terre au moyen de tapis ou d'autres moyens isolants suffisamment grands pour empêcher le contact physique éventuel avec la pièce ou la terre.
- Ne pas se servir de source électrique à courant électrique dans les zones humides, dans les endroits confinés ou là où on risque de tomber.
- Se servir d'une source électrique à courant électrique UNIQUEMENT si le procédé de soudage le demande.
- Si l'utilisation d'une source électrique à courant électrique s'avère nécessaire, se servir de la fonction de télécommande si l'appareil en est équipé.
- Des précautions de sécurité supplémentaires sont requises dans des environnements à risque comme: les endroits humides ou lorsque l'on porte des vêtements mouillés; sur des structures métalliques au sol, grillages et échafaudages; dans des positions assises, à genoux et allongées; ou quand il y a un risque important de contact accidentel avec la pièce ou le sol. Dans ces cas utiliser les appareils suivants dans l'ordre de préférence: 1) un poste à souder DC semi-automatique de type CV (MIG/MAG), 2) un poste à souder manuel (électrode enrobée) DC, 3) un poste à souder manuel AC avec tension à vide réduite. Dans la plupart des cas, un poste courant continu de type CV est recommandé. Et, ne pas travailler seul!
- Couper l'alimentation ou arrêter le moteur avant de procéder à l'installation, à la réparation ou à l'entretien de l'appareil. Déverrouiller l'alimentation selon la norme OSHA 29 CFR 1910.147 (voir normes de sécurité).
- Installer et mettre à la terre correctement cet appareil conformément à son manuel d'utilisation et aux codes nationaux, provinciaux et municipaux.
- Toujours vérifier la terre du cordon d'alimentation – Vérifier et s'assurer que le fil de terre du cordon d'alimentation est bien raccordé à la borne de terre du sectionneur ou que la fiche du cordon est raccordée à une prise correctement mise à la terre.
- En effectuant les raccordements d'entrée fixer d'abord le conducteur de mise à la terre approprié et contre-vérifier les connexions.
- Vérifier fréquemment le cordon d'alimentation pour voir s'il n'est pas endommagé ou dénudé – remplacer le cordon immédiatement s'il est endommagé – un câble dénudé peut provoquer une électrocution.
- Mettre l'appareil hors tension quand on ne l'utilise pas.
- Ne pas utiliser des câbles usés, endommagés, de grosseur insuffisante ou mal éplissés.
- Ne pas enrouler les câbles autour du corps.
- Si la pièce soudée doit être mise à la terre, la faire directement avec un câble distinct – ne pas utiliser le connecteur de pièce ou le câble de retour.
- Ne pas toucher l'électrode quand on est en contact avec la pièce, la terre ou une électrode provenant d'une autre machine.
- Ne pas toucher des porte électrodes connectés à deux machines en même temps à cause de la présence d'une tension à vide doublée.
- N'utiliser qu'un matériel en bon état. Réparer ou remplacer sur-le-champ les pièces endommagées. Entretien de l'appareil conformément à ce manuel.

- Porter un harnais de sécurité quand on travaille en hauteur.
- Maintenir solidement en place tous les panneaux et capots.
- Fixer le câble de retour de façon à obtenir un bon contact métal-métal avec la pièce à souder ou la table de travail, le plus près possible de la soudure.
- Isoler la pince de masse quand pas mis à la pièce pour éviter le contact avec tout objet métallique.

Une tension DC importante subsiste à l'intérieur des onduleurs après avoir coupé l'alimentation.

- Couper l'alimentation du poste et décharger les condensateurs d'entrée comme indiqué dans la Section Maintenance avant de toucher des composants.

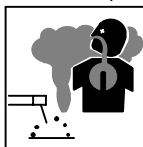

LES FUMÉES ET LES GAZ peuvent être dangereux.

Le soudage génère des fumées et des gaz. Leur inhalation peut être dangereux pour votre santé.

- Eloigner votre tête des fumées. Ne pas respirer les fumées.
- À l'intérieur, ventiler la zone et/ou utiliser une ventilation forcée au niveau de l'arc pour l'évacuation des fumées et des gaz de soudage.
- Si la ventilation est médiocre, porter un respirateur anti-vapeurs approuvé.
- Lire et comprendre les spécifications de sécurité des matériaux (MSDS) et les instructions du fabricant concernant les métaux, les consommables, les revêtements, les nettoyeurs et les dégraisseurs.
- Travailler dans un espace fermé seulement s'il est bien ventilé ou en portant un respirateur à alimentation d'air. Demander toujours à un surveillant dûment formé de se tenir à proximité. Des fumées et des gaz de soudage peuvent déplacer l'air et abaisser le niveau d'oxygène provoquant des blessures ou des accidents mortels. S'assurer que l'air de respiration ne présente aucun danger.
- Ne pas souder dans des endroits situés à proximité d'opérations de dégraissage, de nettoyage ou de pulvérisation. La chaleur et les rayons de l'arc peuvent réagir en présence de vapeurs et former des gaz hautement toxiques et irritants.
- Ne pas souder des métaux munis d'un revêtement, tels que l'acier galvanisé, plaqué en plomb ou au cadmium à moins que le revêtement n'ait été enlevé dans la zone de soudure, que l'endroit soit bien ventilé, et en portant un respirateur à alimentation d'air. Les revêtements et tous les métaux renfermant ces éléments peuvent dégager des fumées toxiques en cas de soudage.

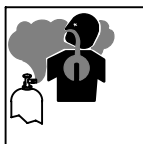

LES ACCUMULATIONS DE GAZ risquent de provoquer des blessures ou même la mort.

- Fermer l'alimentation du gaz protecteur en cas de non utilisation.
- Veiller toujours à bien aérer les espaces confinés ou se servir d'un respirateur d'adduction d'air homologué.

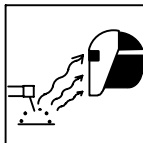

LES RAYONS DE L'ARC peuvent provoquer des brûlures dans les yeux et sur la peau.

Le rayonnement de l'arc du procédé de soudage génère des rayons visibles et invisibles intenses (ultraviolets et infrarouges) susceptibles de provoquer des brûlures dans les yeux et sur la peau. Des étincelles sont projetées pendant le soudage.

- Porter un casque de soudage approuvé muni de verres filtrants appropriés pour protéger visage et yeux pendant le soudage (voir ANSI Z49.1 et Z87.1 énuméré dans les normes de sécurité).
- Porter des lunettes de sécurité avec écrans latéraux même sous votre casque.
- Avoir recours à des écrans protecteurs ou à des rideaux pour protéger les autres contre les rayonnements les éblouissements et les étincelles ; prévenir toute personne sur les lieux de ne pas regarder l'arc.
- Porter des vêtements confectionnés avec des matières résistantes et ignifuges (cuir, coton lourd ou laine) et des bottes de protection.



LE SOUDAGE peut provoquer un incendie ou une explosion.

Le soudage effectué sur des conteneurs fermés tels que des réservoirs, tambours ou des conduites peut provoquer leur éclatement. Des étincelles peuvent être projetées de l'arc de soudure. La projection d'étincelles, des pièces chaudes et des équipements chauds peut provoquer des incendies et des brûlures. Le contact accidentel de l'électrode avec des objets métalliques peut provoquer des étincelles, une explosion, un surchauffement ou un incendie. Avant de commencer le soudage, vérifier et s'assurer que l'endroit ne présente pas de danger.

- Déplacer toutes les substances inflammables à une distance de 10,7 m de l'arc de soudage. En cas d'impossibilité les recouvrir soigneusement avec des protections homologués.
- Ne pas souder dans un endroit où des étincelles peuvent tomber sur des substances inflammables.
- Se protéger et d'autres personnes de la projection d'étincelles et de métal chaud.
- Des étincelles et des matériaux chauds du soudage peuvent facilement passer dans d'autres zones en traversant de petites fissures et des ouvertures.
- Surveiller tout déclenchement d'incendie et tenir un extincteur à proximité.
- Le soudage effectué sur un plafond, plancher, paroi ou séparation peut déclencher un incendie de l'autre côté.
- Ne pas effectuer le soudage sur des conteneurs fermés tels que des réservoirs, tambours, ou conduites, à moins qu'ils n'aient été préparés correctement conformément à AWS F4.1 (voir les normes de sécurité).
- Brancher le câble sur la pièce le plus près possible de la zone de soudage pour éviter le transport du courant sur une longue distance par des chemins inconnus éventuels en provoquant des risques d'électrocution et d'incendie.
- Brancher le câble de masse sur la pièce le plus près possible de la zone de soudage pour éviter le transport du courant sur une longue distance par des chemins inconnus éventuels en provoquant des risques d'électrocution, d'étincelles et d'incendie.
- Ne pas utiliser le poste de soudage pour dégeler des conduites gelées.
- En cas de non utilisation, enlever la baguette d'électrode du porte-électrode ou couper le fil à la pointe de contact.
- Porter des vêtements de protection dépourvus d'huile tels que des gants en cuir, une chemise en matériau lourd, des pantalons sans revers, des chaussures hautes et un couvre chef.
- Avant de souder, retirer toute substance combustible de vos poches telles qu'un allumeur au butane ou des allumettes.
- Suivre les recommandations dans OSHA 1910.252(a)(2)(iv) et NFPA 51B pour les travaux à chaud et avoir de la surveillance et un extincteur à proximité.

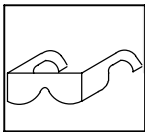

DES PARTICULES VOLANTES peuvent blesser les yeux.

- Le soudage, l'écaillage, le passage de la pièce à la brose en fil de fer, et le meulage génèrent des étincelles et des particules métalliques volantes. Pendant la période de refroidissement des soudures, elles risquent de projeter du laitier.

- Porter des lunettes de sécurité avec écrans latéraux ou un écran facial.



DES PIÈCES CHAUDES peuvent provoquer des brûlures graves.

- Ne pas toucher à mains nues les parties chaudes.
- Prévoir une période de refroidissement avant de travailler à l'équipement.
- Ne pas toucher aux pièces chaudes, utiliser les outils recommandés et porter des gants de soudage et des vêtements épais pour éviter les brûlures.

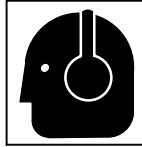

LE BRUIT peut affecter l'ouïe.

Le bruit des processus et des équipements peut affecter l'ouïe.

- Porter des protections approuvés pour les oreilles si le niveau sonore est trop élevé.



LES CHAMPS MAGNÉTIQUES peuvent affecter les stimulateurs cardiaques.

- Porteurs de stimulateur cardiaque, restez à distance.
- Les porteurs d'un stimulateur cardiaque doivent d'abord consulter leur médecin avant de s'approcher des opérations de soudage à l'arc, de gougeage ou de soudage par points.

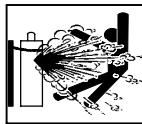

Si des BOUTEILLES sont endommagées, elles pourront exploser.

Des bouteilles de gaz protecteur contiennent du gaz sous haute pression. Si une bouteille est endommagée, elle peut exploser. Du fait que les bouteilles de gaz font normalement partie du procédé de soudage, les manipuler avec précaution.

- Protéger les bouteilles de gaz comprimé d'une chaleur excessive, des chocs mécaniques, des dommages physiques, du laitier, des flammes ouvertes, des étincelles et des arcs.
- Placer les bouteilles debout en les fixant dans un support stationnaire ou dans un porte-bouteilles pour les empêcher de tomber ou de se renverser.
- Tenir les bouteilles éloignées des circuits de soudage ou autres circuits électriques.
- Ne jamais placer une torche de soudage sur une bouteille à gaz.
- Une électrode de soudage ne doit jamais entrer en contact avec une bouteille.
- Ne jamais souder une bouteille pressurisée – risque d'explosion.
- Utiliser seulement des bouteilles de gaz protecteur, régulateurs, tuyaux et raccords convenables pour cette application spécifique; les maintenir ainsi que les éléments associés en bon état.
- Ne pas tenir la tête en face de la sortie en ouvrant la soupape de la bouteille.
- Maintenir le chapeau de protection sur la soupape, sauf en cas d'utilisation ou de branchement de la bouteille.
- Utiliser les équipements corrects, les bonnes procédures et suffisamment de personnes pour soulever et déplacer les bouteilles.
- Lire et suivre les instructions sur les bouteilles de gaz comprimé, l'équipement connexe et le dépliant P-1 de la CGA (Compressed Gas Association) mentionné dans les principales normes de sécurité.

2-3. Dangers existant en relation avec le moteur

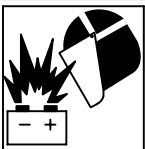

L'EXPLOSION DE LA BATTERIE peut RENDRE AVEUGLE.

- Toujours porter une protection faciale, des gants en caoutchouc et vêtements de protection lors d'une intervention sur la batterie.

- Arrêter le moteur avant de débrancher ou de brancher les câbles de batterie.
- Éviter de provoquer des étincelles avec les outils en travaillant sur la batterie.
- Ne pas utiliser le poste de soudage pour charger les batteries ou des véhicules de démarrage rapide.
- Observer la polarité correcte (+ et -) sur les batteries.
- Débrancher le câble négatif (-) en premier lieu. Le rebrancher en dernier lieu.



LE CARBURANT MOTEUR peut provoquer un incendie ou une explosion.

- Arrêter le moteur avant de vérifier le niveau de carburant ou de faire le plein.

- Ne pas faire le plein en fumant ou proche d'une source d'étincelles ou d'une flamme nue.
- Ne pas faire le plein de carburant à ras bord; prévoir de l'espace pour son expansion.
- Faire attention de ne pas renverser de carburant. Nettoyer tout carburant renversé avant de faire démarrer le moteur.
- Jeter les chiffons dans un récipient ignifuge.



DES ORGANES MOBILES peuvent provoquer des blessures.

- Ne pas approcher les mains des ventilateurs, courroies et autres pièces en mouvement.

- Maintenir fermés et fixement en place les portes, panneaux, recouvrements et dispositifs de protection.



DES PIÈCES CHAUDES peuvent provoquer des brûlures et blessures.

- Ne pas toucher les parties chaudes du moteur.
- Laisser l'ensemble se refroidir avant d'effectuer la maintenance.

- Porter des gants et des vêtements de protection pour travailler sur un moteur chaud.

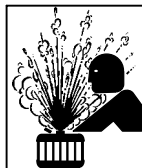

LA VAPEUR ET LE LIQUIDE DE REFROIDISSEMENT CHAUD peuvent provoquer des brûlures.

- Il est préférable de vérifier le liquide de refroidissement une fois le moteur refroidi pour éviter de se brûler.

- Toujours vérifier le niveau de liquide de refroidissement dans le vase d'expansion (si présent), et non dans le radiateur (sauf si précisé autrement dans la section maintenance du manuel du moteur).

- Si le moteur est chaud et que le liquide doit être vérifié, opérer comme suivant.
- Mettre des lunettes de sécurité et des gants, placer un torchon sur le bouchon du radiateur.
- Dévisser le bouchon légèrement et laisser la vapeur s'échapper avant d'enlever le bouchon.



LES ACCUMULATIONS DE GAZ risquent de provoquer des blessures ou même la mort.

- Fermer l'alimentation du gaz protecteur en cas de non utilisation.
- Veiller toujours à bien aérer les espaces confinés ou se servir d'un respirateur d'adduction d'air homologué.

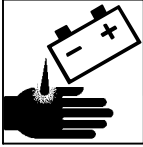

L'ACIDE DE LA BATTERIE peut provoquer des brûlures dans les YEUX et sur la PEAU.

- Ne pas renverser la batterie.
- Remplacer une batterie endommagée.
- Rincer immédiatement les yeux et la peau à l'eau.



- Ne pas placer l'appareil sur, au-dessus ou à proximité de surfaces inflammables.

- Tenir à distance les produits inflammables de l'échappement.



LES ÉTINCELLES À L'ÉCHAPPEMENT peuvent provoquer un incendie.

- Empêcher les étincelles d'échappement du moteur de provoquer un incendie.
- Utiliser uniquement un pare-étincelles approuvé – voir codes en vigueur.

2-4. Dangers liés à l'air comprimé



RESPIRER L'AIR COMPRIMÉ peut provoquer des blessures graves ou causer la mort.

- Ne pas utiliser l'air comprimé pour respirer.
- Utiliser l'air comprimé seulement pour le coupage, gougeage et les outils pneumatiques.



L'AIR COMPRIMÉ peut provoquer des blessures.

- Porter des lunettes de sécurité approuvées.
- Ne pas diriger le jet d'air vers d'autres ou soi-même.



L'AIR COMPRI ME EMMAGASINE ET DES TUYAUX SOUS PRESSION peuvent provoquer des blessures.

- Relâcher la pression d'air de l'outillage ou du système avant d'effectuer la maintenance, avant de changer ou de rajouter des éléments ou avant d'ouvrir la purge ou le bouchon de remplissage d'huile.



Le METAL CHAUD lors du coupage et gougeage plasma peut provoquer un incendie ou une explosion.

- Ne pas couper ou gouger à proximité de produits inflammables.
- Surveillez et garder un extincteur à proximité.

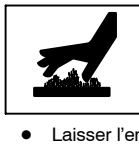

DES PIÈCES CHAUDES peuvent provoquer des brûlures et blessures.

- Ne pas toucher le compresseur ou d'autres éléments du circuit air comprimé chauds.

- Laisser l'ensemble se refroidir avant de toucher ou d'effectuer la maintenance.

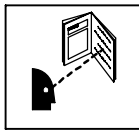

LIRE LES INSTRUCTIONS.

- Lisez le manuel d'instructions avant l'utilisation ou la maintenance de l'appareil.
- Arrêter le moteur et relâcher la pression avant d'effectuer la maintenance.

- Utiliser uniquement des pièces de rechange Miller/Hobart.

2-5. Dangers supplémentaires en relation avec l'installation, le fonctionnement et la maintenance

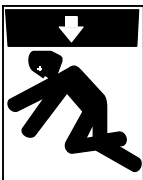

LA CHUTE DE L'APPAREIL peut blesser.

- Utiliser un œilleton de levage pour lever l'appareil et les accessoires correctement installés. Ne pas dépasser le poids nominal maximal de l'œilleton (voir les spécifications).
- Ne lever et ne soutenir l'appareil qu'avec de l'équipement approprié et en suivant les procédures adéquates.

- En utilisant des fourches de levage pour déplacer l'unité, s'assurer que les fourches sont suffisamment longues pour dépasser du côté opposé de l'appareil.

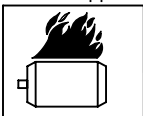

LE SURCHAUFFEMENT peut endommager le moteur électrique.

- Arrêter ou déconnecter l'équipement avant de démarrer ou d'arrêter le moteur.
- Ne pas laisser tourner le moteur trop lentement sous risque d'endommager le moteur électrique à cause d'une tension et d'une fréquence trop faibles.
- Ne pas brancher de moteur de 50 ou de 60 Hz à la prise de 100 Hz, s'il y a lieu.

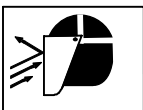

LES ÉTINCELLES VOLANTES risquent de provoquer des blessures.

- Porter un écran facial pour protéger le visage et les yeux.

- Affûter l'électrode au tungstène uniquement à la meuleuse dotée de protecteurs. Cette manœuvre est à exécuter dans un endroit sûr lorsque l'on porte l'équipement homologué de protection du visage, des mains et du corps.
- Les étincelles risquent de causer un incendie – éloigner toute substance inflammable.

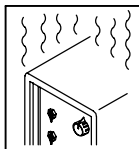

L'EMPLOI EXCESSIF peut SURCHAUFFER L'ÉQUIPEMENT.

- Laisser l'équipement refroidir ; respecter le facteur de marche nominal.
- Réduire le courant ou le facteur de marche avant de poursuivre le soudage.
- Ne pas obstruer les passages d'air du poste.

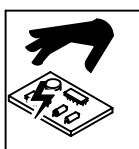

LES CHARGES ÉLECTROSTATIQUES peuvent endommager les circuits imprimés.

- Établir la connexion avec la barrette de terre avant de manipuler des cartes ou des pièces.
- Utiliser des pochettes et des boîtes antistatiques pour stocker, déplacer ou expédier des cartes de circuits imprimés.



UNE REMORQUE QUI BASCULE peut entraîner des blessures.

- Utiliser les supports de la remorque ou des blocs pour soutenir le poids.
- Installer convenablement le poste sur la remorque comme indiqué dans le manuel s'y rapportant.

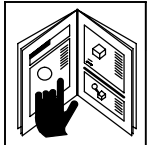

LIRE LES INSTRUCTIONS.

- Utiliser seulement les pièces de rechange d'origine.
- Effectuer la maintenance du moteur et du compresseur (si applicable) suivant ce manuel et le manuel du moteur/compresseur (si applicable).

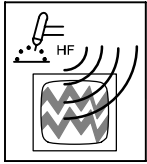

LE RAYONNEMENT HAUTE FRÉQUENCE (H.F.) risque de provoquer des interférences.

- Le rayonnement haute fréquence (H.F.) peut provoquer des interférences avec les équipements de radio-navigation et de communication, les services de sécurité et les ordinateurs.
- Demander seulement à des personnes qualifiées familiarisées avec des équipements électroniques de faire fonctionner l'installation.
- L'utilisateur est tenu de faire corriger rapidement par un électricien qualifié les interférences résultant de l'installation.
- Si le FCC signale des interférences, arrêter immédiatement l'appareil.
- Effectuer régulièrement le contrôle et l'entretien de l'installation.
- Maintenir soigneusement fermés les portes et les panneaux des sources de haute fréquence, maintenir les éclateurs à une distance correcte et utiliser une terre et un blindage pour réduire les interférences éventuelles.

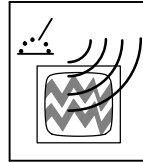

LE SOUDAGE À L'ARC risque de provoquer des interférences.

- L'énergie électromagnétique risque de provoquer des interférences pour l'équipement électronique sensible tel que les ordinateurs et l'équipement commandé par ordinateur tel que les robots.
- Veiller à ce que tout l'équipement de la zone de soudage soit compatible électromagnétiquement.
- Pour réduire la possibilité d'interférence, maintenir les câbles de soudage aussi courts que possible, les grouper, et les poser aussi bas que possible (ex. par terre).
- Veiller à souder à une distance de 100 mètres de tout équipement électronique sensible.
- Veiller à ce que ce poste de soudage soit posé et mis à la terre conformément à ce mode d'emploi.
- En cas d'interférences après avoir pris les mesures précédentes, il incombe à l'utilisateur de prendre des mesures supplémentaires telles que le déplacement du poste, l'utilisation de câbles blindés, l'utilisation de filtres de ligne ou la pose de protecteurs dans la zone de travail.

2-6. Proposition californienne 65 Avertissements

- ▲ Les équipements de soudage et de coupage produisent des fumées et des gaz qui contiennent des produits chimiques dont l'État de Californie reconnaît qu'ils provoquent des malformations congénitales et, dans certains cas, des cancers. (Code de santé et de sécurité de Californie, chapitre 25249.5 et suivants)
- ▲ Les batteries, les bornes et autres accessoires contiennent du plomb et des composés à base de plomb, produits chimiques dont l'État de Californie reconnaît qu'ils provoquent des cancers et des malformations congénitales ou autres problèmes de procréation. Se laver les mains après manipulation.

Pour les moteurs à essence :

- ▲ Les gaz d'échappement des moteurs contiennent des produits chimiques dont l'État de Californie reconnaît qu'ils provoquent des cancers et des malformations congénitales ou autres problèmes de procréation.

Pour les moteurs diesel :

- ▲ Les gaz d'échappement des moteurs diesel et certains de leurs composants sont reconnus par l'État de Californie comme provoquant des cancers et des malformations congénitales ou autres problèmes de procréation.

2-7. Principales normes de sécurité

Safety in Welding, Cutting, and Allied Processes, ANSI Standard Z49.1, de Global Engineering Documents (téléphone : 1-877-413-5184, site Internet : www.global.ihs.com).

Recommended Safe Practices for the Preparation for Welding and Cutting of Containers and Piping, American Welding Society Standard AWS F4.1 de Global Engineering Documents (téléphone : 1-877-413-5184, site Internet : www.global.ihs.com).

National Electrical Code, NFPA Standard 70, de National Fire Protection Association, P.O. Box 9101, 1 Battery March Park, Quincy, MA 02269-9101 (téléphone : 617-770-3000, site Internet : www.nfpa.org).

Safe Handling of Compressed Gases in Cylinders, CGA Pamphlet P-1, de Compressed Gas Association, 1735 Jefferson Davis Highway, Suite 1004, Arlington, VA 22202-4102 (téléphone : 703-412-0900, site Internet : www.cganet.com).

Code for Safety in Welding and Cutting, CSA Standard W117.2, de Canadian Standards Association, Standards Sales, 178 Rexdale

Boulevard, Rexdale, Ontario, Canada M9W 1R3 (téléphone : 800-463-6727 ou à Toronto 416-747-4044, site Internet : www.csa-international.org).

Practice For Occupational And Educational Eye And Face Protection, ANSI Standard Z87.1, de American National Standards Institute, 11 West 42nd Street, New York, NY 10036-8002 (téléphone : 212-642-4900, site Internet : www.ansi.org).

Standard for Fire Prevention During Welding, Cutting, and Other Hot Work, NFPA Standard 51B, de National Fire Protection Association, P.O. Box 9101, 1 Battery March Park, Quincy, MA 02269-9101 (téléphone : 617-770-3000, site Internet : www.nfpa.org).

OSHA, Occupational Safety and Health Standards for General Industry, Title 29, Code of Federal Regulations (CFR), Part 1910, Subpart Q, and Part 1926, Subpart J, de U.S. Government Printing Office, Superintendent of Documents, P.O. Box 371954, Pittsburgh, PA 15250 (il y a 10 bureaux régionaux—le téléphone de la région 5, Chicago, est 312-353-2220, site Internet : www.osha.gov).

2-8. Information EMF

Considérations sur le soudage et les effets de basse fréquence et des champs magnétiques et électriques.

Le courant de soudage, pendant son passage dans les câbles de soudage, causera des champs électromagnétiques. Il y a eu et il y a encore un certain souci à propos de tels champs. Cependant, après avoir examiné plus de 500 études qui ont été faites pendant une période de recherche de 17 ans, un comité spécial ruban bleu du National Research Council a conclu : « L'accumulation de preuves, suivant le jugement du comité, n'a pas démontré que l'exposition aux champs magnétiques et champs électriques à haute fréquence représente un risque à la santé humaine ». Toutefois, des études sont toujours en cours et les preuves continuent à être examinées. En attendant que les conclusions finales de la recherche soient établies, il vous serait souhaitable de réduire votre exposition aux champs électromagnétiques pendant le soudage ou le coupage.

Pour réduire les champs magnétiques sur le poste de travail, appliquer les

procédures suivantes :

















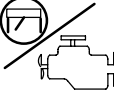

1. Maintenir les câbles ensemble en les tordant ou en les enveloppant.
2. Disposer les câbles d'un côté et à distance de l'opérateur.
3. Ne pas courber pas et ne pas entourer pas les câbles autour de votre corps.
4. Garder le poste de soudage et les câbles le plus loin possible de vous.
5. Connecter la pince sur la pièce aussi près que possible de la soudure.

En ce qui concerne les stimulateurs cardiaques

Les porteurs de stimulateur cardiaque doivent consulter leur médecin avant de souder ou d'approcher des opérations de soudage. Si le médecin approuve, il est recommandé de suivre les procédures précédentes.

SECTION 3 – DEFINITIONS

3-1. Symbol Definitions

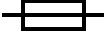
	Stop Engine		Fast (Run, Weld/Power)		Fast/Slow (Run/Idle)		Slow (Idle)
	Start Engine		Read Operator's Manual	A	Amperes	V	Volts
	Engine Oil		Fuel		Battery (Engine)		Engine
	Engine Choke		Check Valve Clearance		Circuit Protector		Temperature
+	Positive	—	Negative		Alternating Current (AC)		Output
h	Hours	s	Seconds		Time		Protective Earth (Ground)
	Welding Arc (Electrode)		Stick (SMAW)		Fuse		

SECTION 4 – SPECIFICATIONS

4-1. Weld, Power, and Engine Specifications

Note  This unit uses either a Robin or a Kohler engine. Differences between models are noted throughout this manual.

Welding Mode	Weld Output Range	Rated Welding Output	Maximum Open Circuit Voltage	Single-Phase Generator Power Rating	Fuel Capacity	Engine
CC/DC	50 – 230 A	230 A, 25 V, 30% Duty Cycle 210 A, 25 V, 60% Duty Cycle 170 A, 25 V, 100% Duty Cycle	73	Peak: 10 kVA/kW, 84/42 A, 120/240 V AC, 60 Hz Continuous: 9.5 kVA/kW (while not welding)	10 gal (38 L) Tank	Robin Air-Cooled, Two-Cylinder, Four-Cycle, 22 HP Gasoline Engine or Kohler CH-20 Air-Cooled, Two-Cylinder, Four-Cycle, 20 HP Gasoline Engine

4-2. Dimensions, Weights, and Operating Angles

Dimensions	
Height	33-1/2 in (851 mm)
Width	18-1/2 in (470 mm)
Depth	38 in (965 mm)
A	18 in (457 mm)
B	16-9/16 in (421 mm)
C	23/32 in (18 mm)
D	3 in (76 mm)
E	31-1/2 in (800 mm)
F	37-1/2 in (953 mm)
G	13/32 in (10 mm) Dia.
Weight	
Robin-Powered Unit:	445 lb (202 kg)
Kohler-Powered Unit:	444 lb (201 kg)
Lifting Eye Weight Rating	
	1280 lb (580 kg)

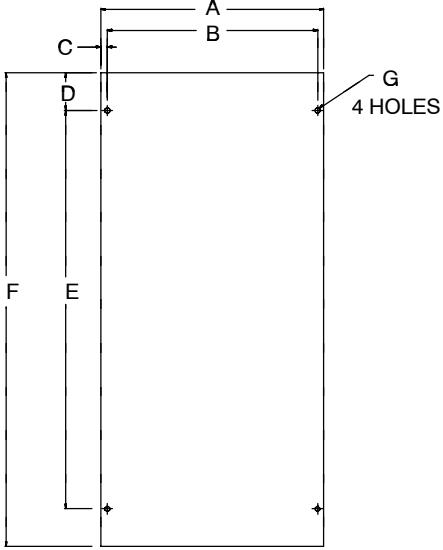

4 HOLES

802 855



- ▲ Do not exceed tilt angles or engine could be damaged or unit could tip.
- ▲ Do not move or operate unit where it could tip.

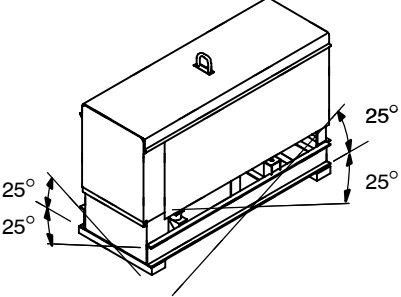

4-3. Generator Power Curve

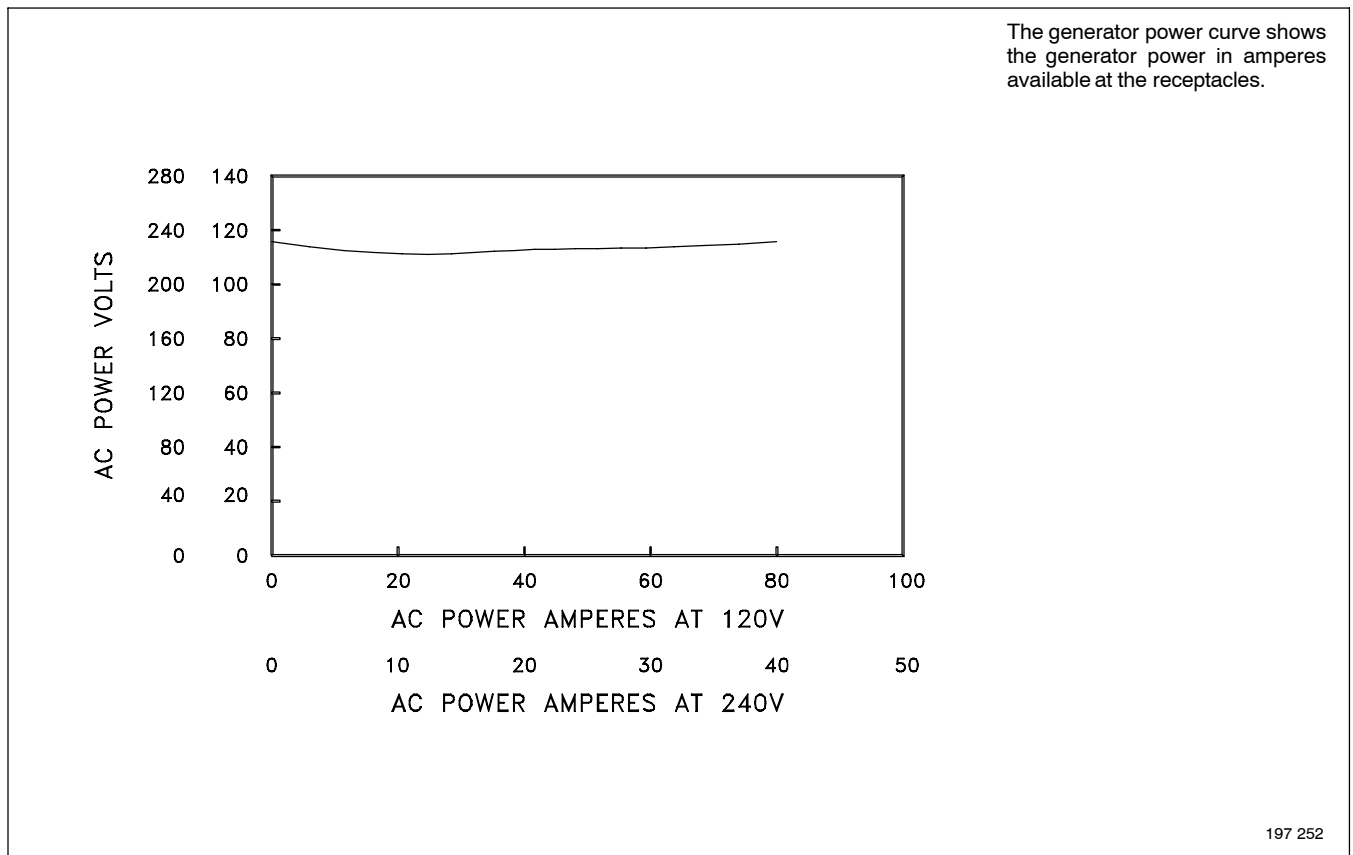

4-4. Fuel Consumption (All Models)

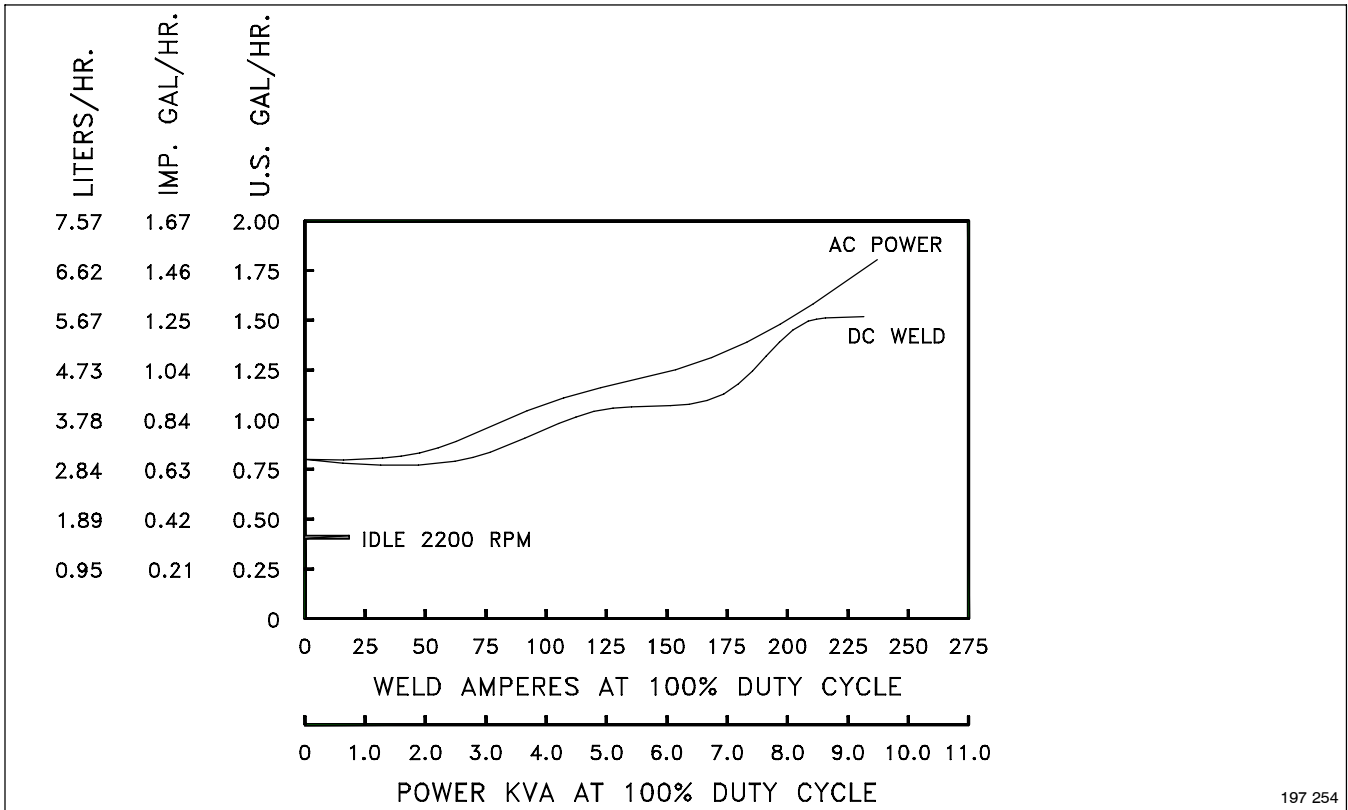

197 254

4-5. Duty Cycle

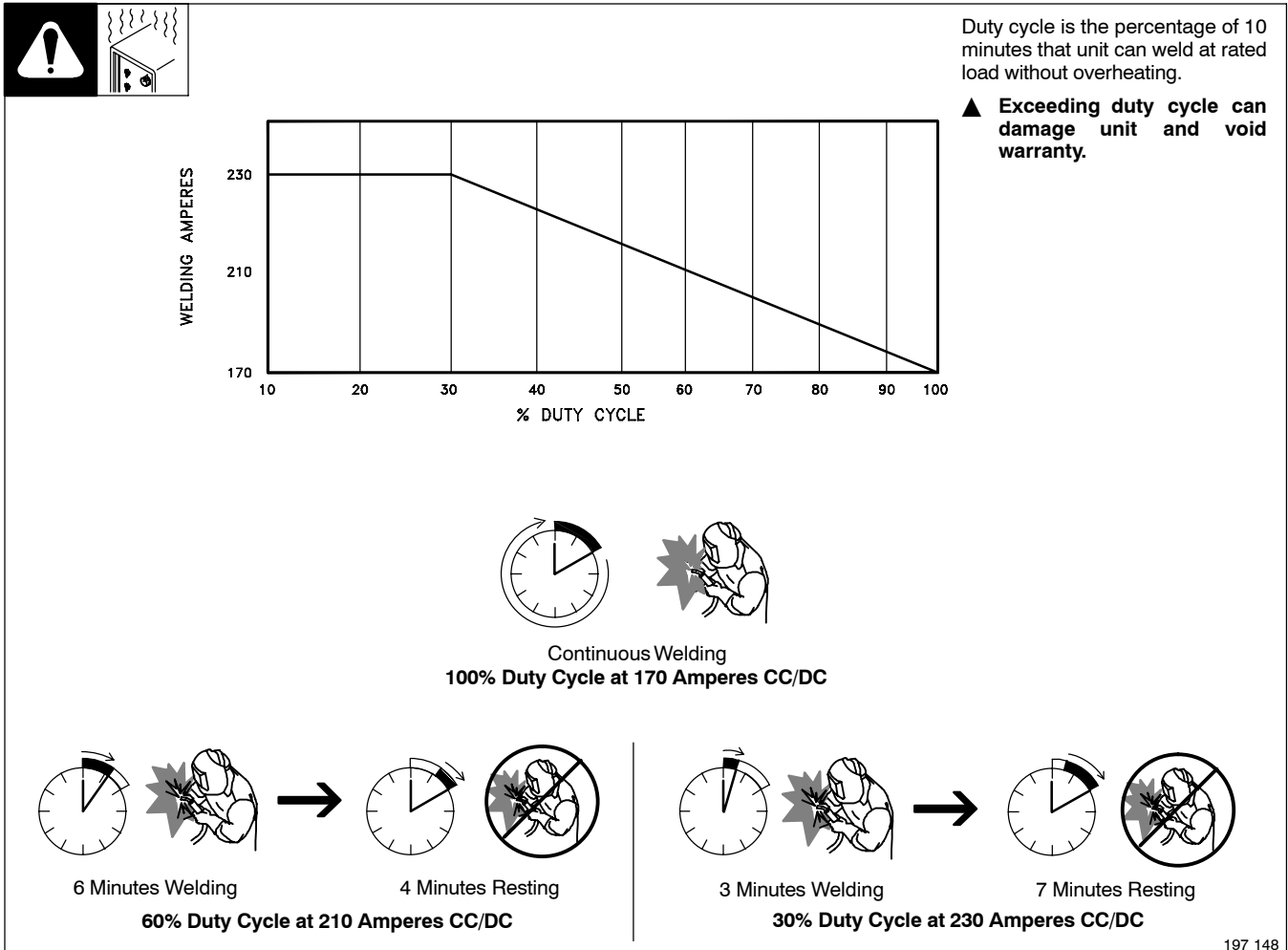

197 148

4-6. Volt-Ampere Curves

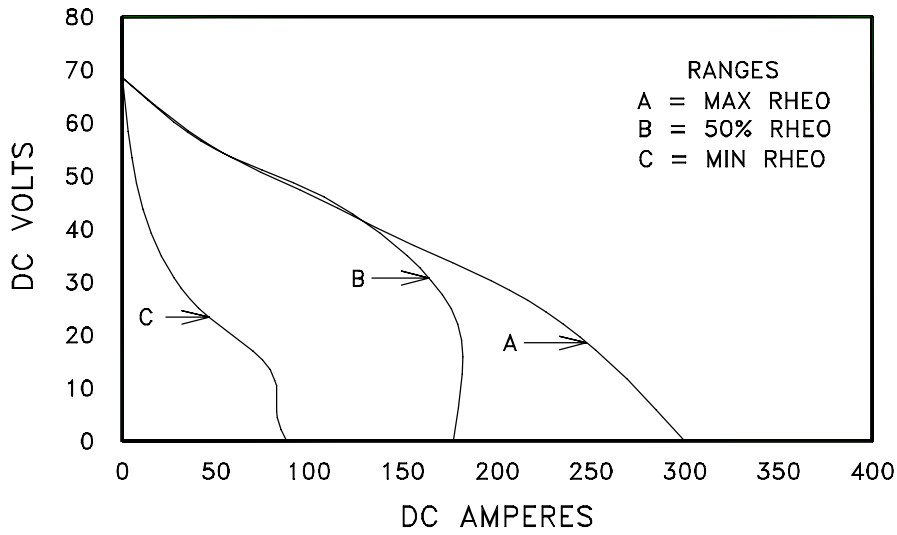

The volt-ampere curve shows the minimum and maximum voltage and amperage output capabilities of the welding generator. Curves of all other settings fall between the curves shown.

197 253

Notes

MATERIAL THICKNESS REFERENCE CHART

	24 Gauge (.025 in)
	22 Gauge (.031 in)
	20 Gauge (.037 in)
	18 Gauge (.050 in)
	16 Gauge (.063 in)
	14 Gauge (.078 in)
	1/8 in (.125 in)
	3/16 in (.188 in)
	1/4 in (.25 in)
	5/16 in (.313 in)
	3/8 in (.375 in)
	1/2 in (.5 in)

SECTION 5 – INSTALLATION

5-1. Installing Welding Generator



Movement

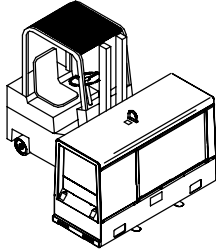

▲ Do not lift unit from end.

OR

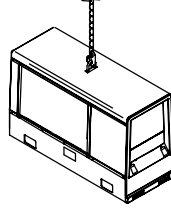

Location / Airflow Clearance

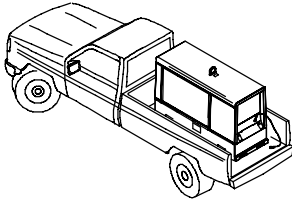

OR

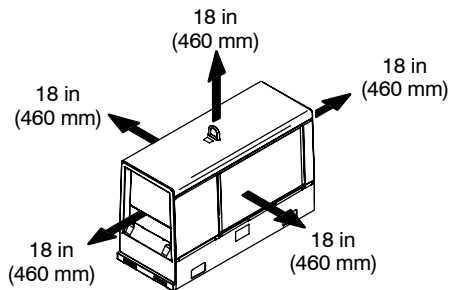
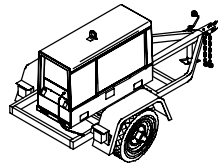

- ▲ Do not weld on base. Welding on base can cause fuel tank fire or explosion. Bolt unit down using holes provided in base.
- ▲ Always securely fasten welding generator onto transport vehicle or trailer and comply with all DOT and other applicable codes.
- ▲ Do not mount unit by supporting the base only at the four mounting holes. Use cross-supports to adequately support unit and prevent damage to base.
- ▲ Always ground generator frame to vehicle frame to prevent electric shock and static electricity hazards.
- ▲ If unit does not have GFCI receptacles, use GFCI-protected extension cord.

Mounting:

- 1 Cross-Supports

Mount unit on flat surface or use cross-supports to support base.

Grounding:

- 2 Equipment Grounding Terminal (On Front Panel)
- 3 Grounding Cable (Not Supplied)
- 4 Metal Vehicle Frame

Connect cable from equipment ground terminal to metal vehicle frame. Use #10 AWG or larger insulated copper wire.

Mounting

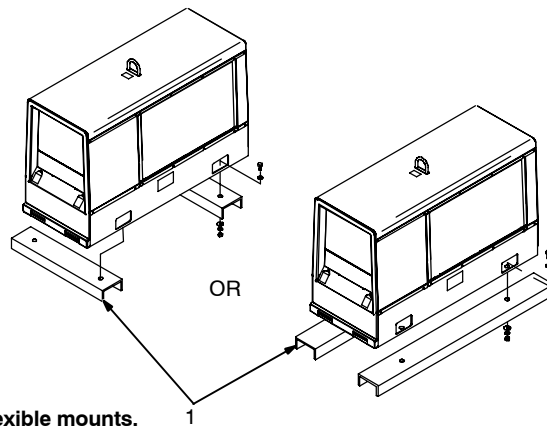
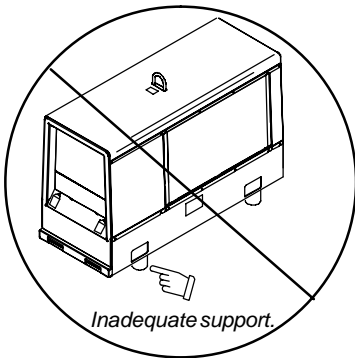

▲ Do not use flexible mounts.

Grounding

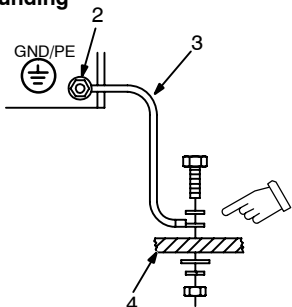

- ▲ Bed liners, shipping skids, and some running gears insulate the welding generator from the vehicle frame. Always connect a ground wire from the generator equipment grounding terminal to bare metal on the vehicle frame as shown.

Electrically bond generator frame to vehicle frame by metal-to-metal contact.

5-2. Engine Prestart Checks (Robin-Powered Units)

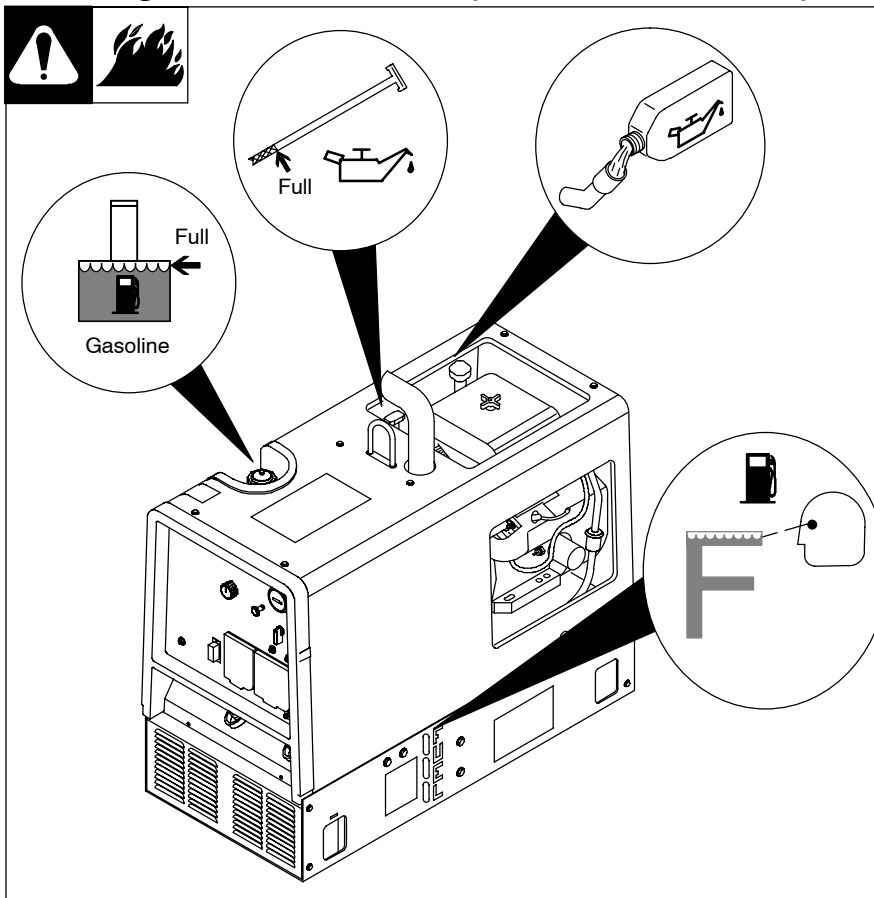

The diagram shows a side view of a generator with callouts for fuel and oil. A callout for the fuel tank shows a dipstick with a 'Full' mark and a fuel can. A callout for the oil dipstick shows a dipstick with a 'Full' mark and an oil can. A callout for the fuel tank window shows a fuel can and a dipstick with a 'Full' mark. A callout for the oil dipstick shows a dipstick with a 'Full' mark and an oil can. A callout for the fuel tank window shows a fuel can and a dipstick with a 'Full' mark. A callout for the oil dipstick shows a dipstick with a 'Full' mark and an oil can.

Check all fluids daily. Engine must be cold and on a level surface. Unit is shipped with 10W30 engine oil.

Engine stops if oil pressure gets too low.

- ☞ Follow run-in procedure in engine manual.
- ☞ This unit has a low oil pressure shutdown switch. However, some conditions may cause engine damage before the engine shuts down. Check oil level often and do not use the oil pressure shutdown system to monitor oil level.

Fuel

To help prime the fuel system at initial start-up, fill tank with fresh fuel (see maintenance label for specifications). Always leave filler neck empty to allow room for expansion (see fuel tank window on base). Check fuel level on a cold engine before use each day.

Oil

- ☞ Do not exceed the "Full" mark on the oil level dipstick. The fuel pump may operate erratically if crankcase is overfilled.

After fueling, check oil with unit on level surface. If oil is not up to full mark on dipstick, add oil (see maintenance label).

- ☞ To improve cold weather starting:

Keep battery in good condition. Store battery in warm area.

Use correct grade oil for cold weather.

802 353-G

5-3. Engine Prestart Checks (Kohler-Powered Units)

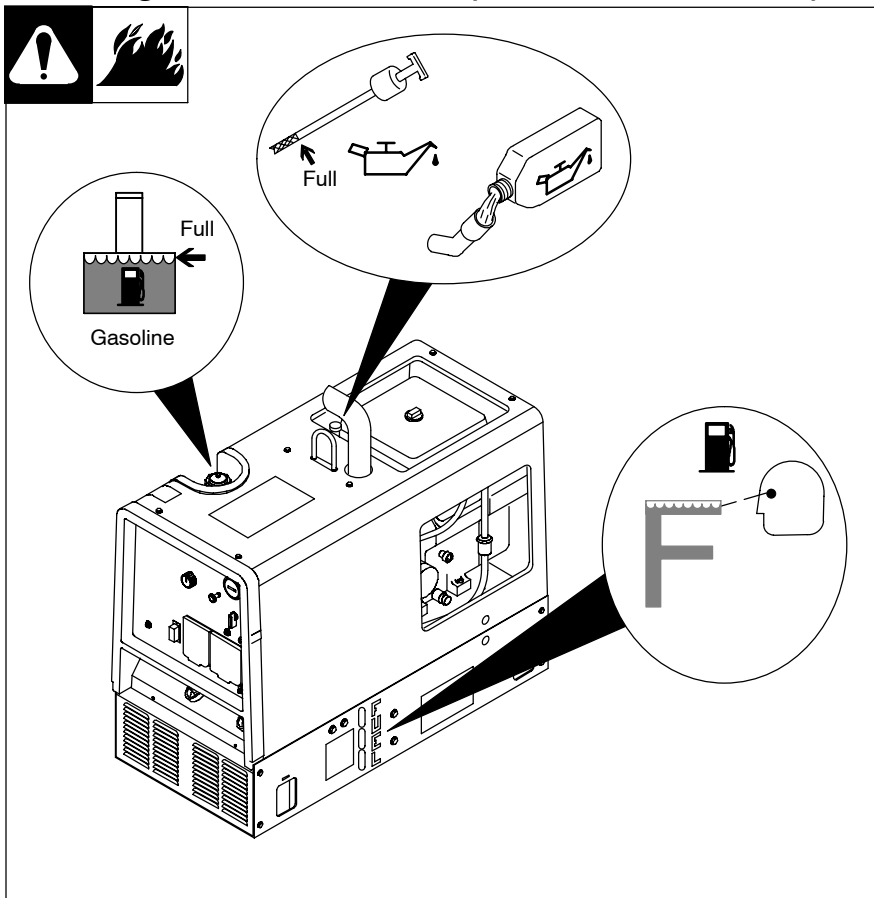

The diagram shows a side view of a generator with callouts for fuel and oil. A callout for the fuel tank shows a dipstick with a 'Full' mark and a fuel can. A callout for the oil dipstick shows a dipstick with a 'Full' mark and an oil can. A callout for the fuel tank window shows a fuel can and a dipstick with a 'Full' mark. A callout for the oil dipstick shows a dipstick with a 'Full' mark and an oil can. A callout for the fuel tank window shows a fuel can and a dipstick with a 'Full' mark. A callout for the oil dipstick shows a dipstick with a 'Full' mark and an oil can.

Check all fluids daily. Engine must be cold and on a level surface. Unit is shipped with 10W30 engine oil.

Engine stops if oil pressure gets too low.

- ☞ Follow run-in procedure in engine manual.
- ☞ This unit has a low oil pressure shutdown switch. However, some conditions may cause engine damage before the engine shuts down. Check oil level often and do not use the oil pressure shutdown system to monitor oil level.

Fuel

To help prime the fuel system at initial start-up, fill tank with fresh fuel (see maintenance label for specifications). Always leave filler neck empty to allow room for expansion (see fuel tank window on base). Check fuel level on a cold engine before use each day.

Oil

- ☞ Do not exceed the "Full" mark on the oil level dipstick. The fuel pump may operate erratically if crankcase is overfilled.

After fueling, check oil with unit on level surface. If oil is not up to full mark on dipstick, add oil (see maintenance label).

- ☞ To improve cold weather starting:

Keep battery in good condition. Store battery in warm area.

Use correct grade oil for cold weather.

802 339-G

5-4. Activating The Dry Charge Battery (If Applicable)

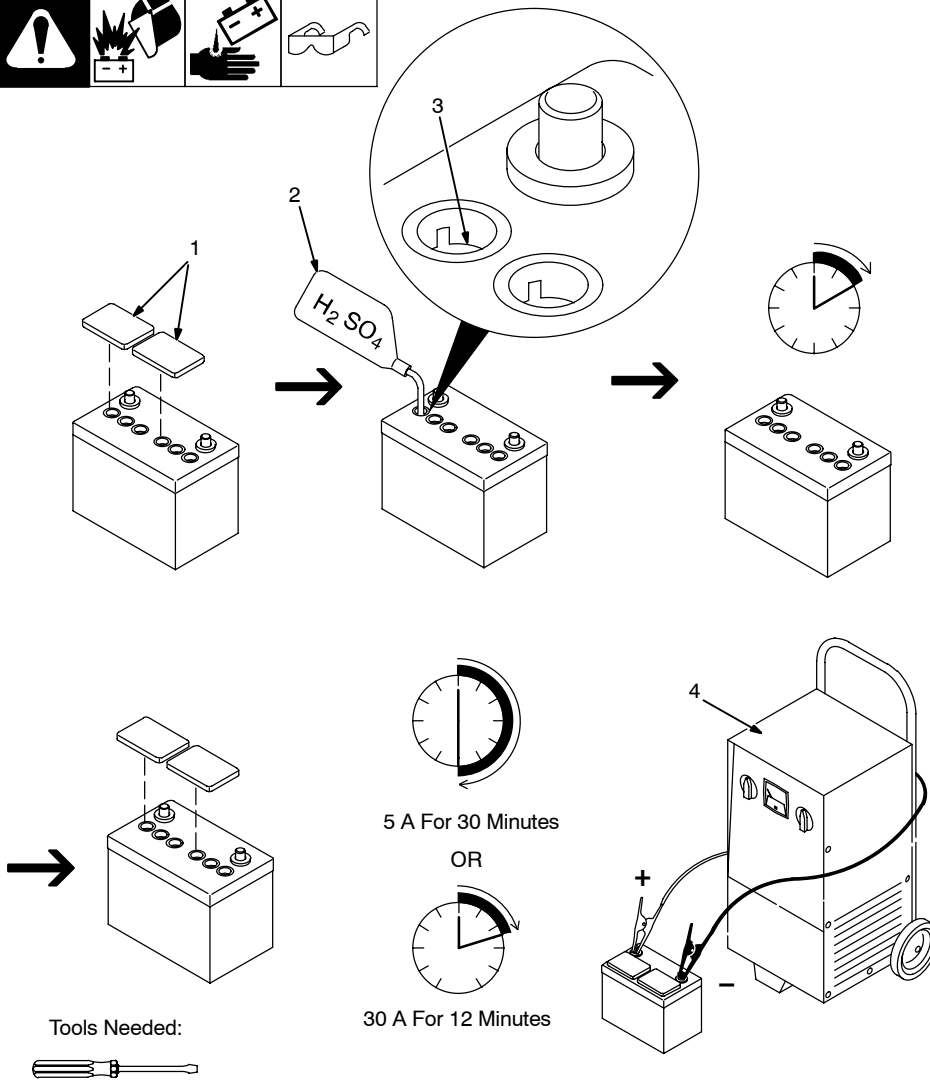
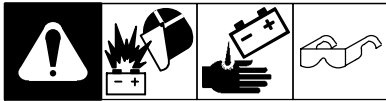

▲ Always wear a face shield, rubber gloves and protective clothing when working on a battery.

Remove battery from unit.

- 1 Vent Caps
- 2 Sulfuric Acid Electrolyte (1.265 Specific Gravity)
- 3 Well

Fill each cell with electrolyte to **bottom** of well (maximum).

▲ Do not overfill battery cells.

Wait ten minutes and check electrolyte level. If necessary, add electrolyte to raise to proper level. Reinstall vent caps.

- 4 Battery Charger

▲ Read and follow all instructions supplied with battery charger.

Charge battery for 12 minutes at 30 amperes or 30 minutes at 5 amperes. Disconnect charging cables and install battery.

☞ When electrolyte is low, add only distilled water to cells to maintain proper level.

drybatt1 6/05 - S-0886

5-5. Connecting the Battery

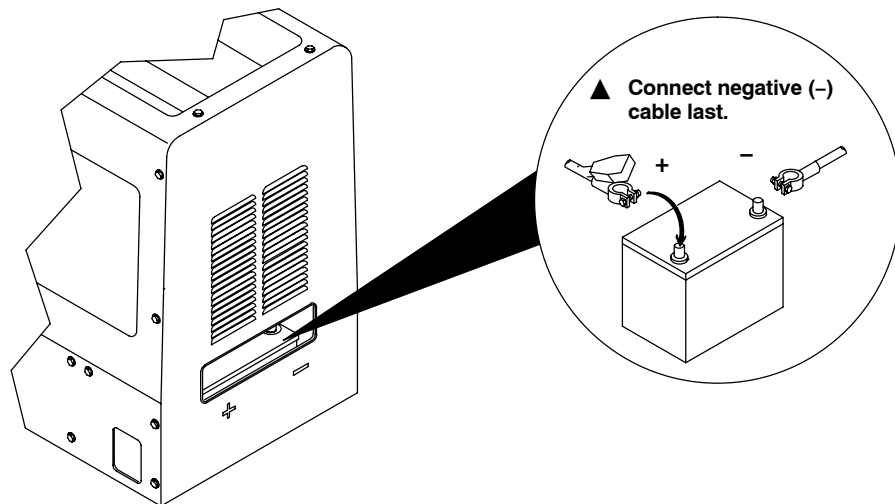
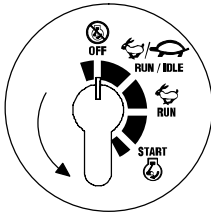

Tools Needed:

- 1/2 in Wrench

Ref. 226 427-A / Ref. 802 341 / Ref. S-0756-D

5-6. Installing Exhaust Pipe

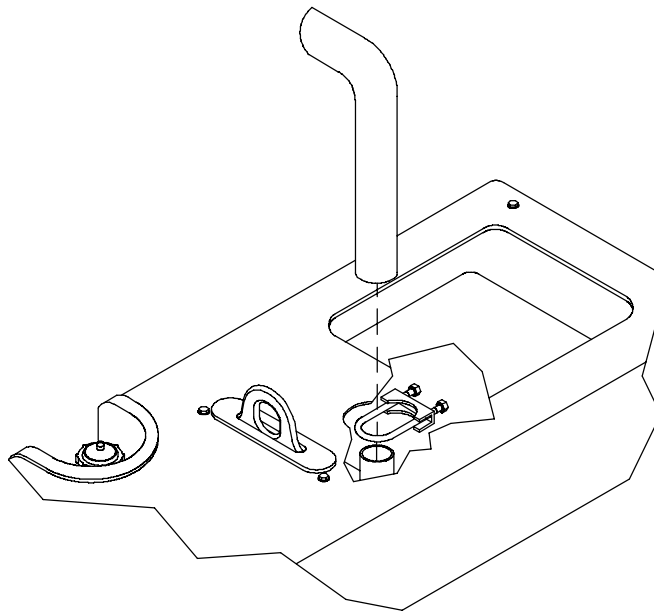
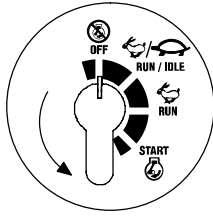

▲ Engine backfire can cause severe burns or other injuries. Do not point exhaust pipe toward control panel. Keep away from exhaust outlet.

☞ Point exhaust pipe in desired direction but always away from front panel and direction of travel.

Tools Needed:

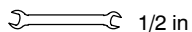

801 681 / Ref. 226 427-A

5-7. Weld Output Terminals

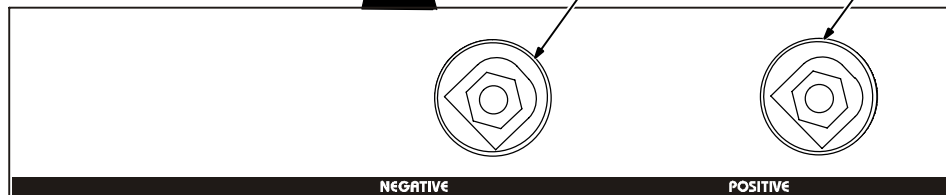
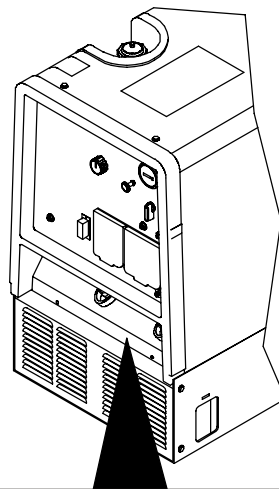

- 1 Negative (-) Weld Output Terminal
- 2 Positive (+) Weld Output Terminal

For Direct Current Electrode Positive (DCEP), connect work cable to Negative (-) terminal and electrode holder cable to Positive (+) terminal.

For Direct Current Electrode Negative (DCEN), reverse cable connections.

Tools Needed:

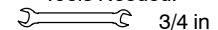

802 353-G / Ref. 226 427-A

5-8. Connecting To Weld Output Terminals

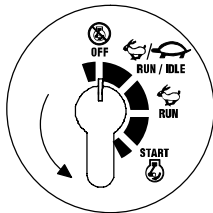



▲ Stop engine.

▲ Failure to properly connect weld cables may cause excessive heat and start a fire, or damage your machine.

- 1 Weld Output Terminal
- 2 Supplied Weld Output Terminal Nut
- 3 Weld Cable Terminal
- 4 Copper Bar

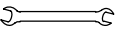
Remove supplied nut from weld output terminal. Slide weld cable terminal onto weld output terminal and secure with nut so that weld cable terminal is tight against copper bar. **Do not place anything between weld cable terminal and copper bar. Make sure that the surfaces of the weld cable terminal and copper bar are clean.**

Tools Needed:
 3/4 in

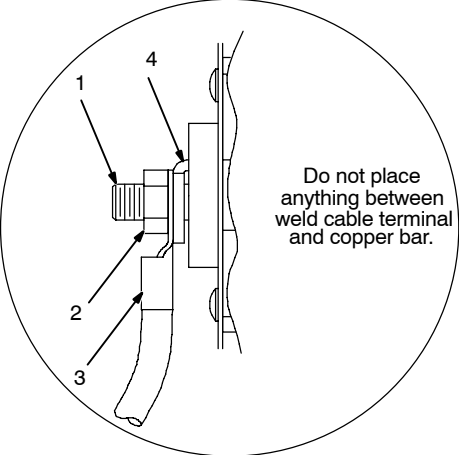

Do not place anything between weld cable terminal and copper bar.

Correct Installation

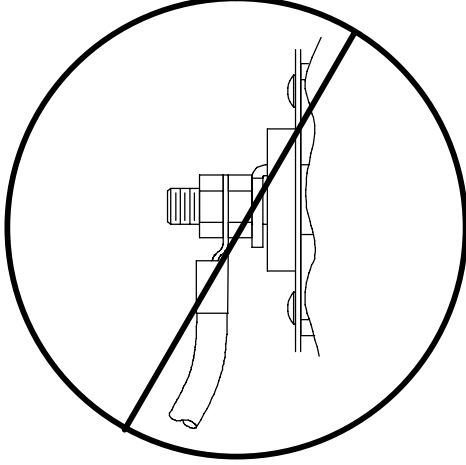

Incorrect Installation

803 778-A / Ref. 226 427-A

5-9. Selecting Weld Cable Sizes*

 Weld Output Terminals	Welding Amperes	Weld Cable Size** and Total Cable (Copper) Length in Weld Circuit Not Exceeding***							
		100 ft (30 m) or Less		150 ft (45 m)	200 ft (60 m)	250 ft (70 m)	300 ft (90 m)	350 ft (105 m)	400 ft (120 m)
		10 – 60% Duty Cycle	60 – 100% Duty Cycle	10 – 100% Duty Cycle					
<p>▲ Turn off power before connecting to weld output terminals.</p> <p>▲ Do not use worn, damaged, undersized, or poorly spliced cables.</p>	100	4 (20)	4 (20)	4 (20)	3 (30)	2 (35)	1 (50)	1/0 (60)	1/0 (60)
	150	3 (30)	3 (30)	2 (35)	1 (50)	1/0 (60)	2/0 (70)	3/0 (95)	3/0 (95)
	200	3 (30)	2 (35)	1 (50)	1/0 (60)	2/0 (70)	3/0 (95)	4/0 (120)	4/0 (120)
	250	2 (35)	1 (50)	1/0 (60)	2/0 (70)	3/0 (95)	4/0 (120)	2 ea. 2/0 (2x70)	2 ea. 2/0 (2x70)
	300	1 (50)	1/0 (60)	2/0 (70)	3/0 (95)	4/0 (120)	2 ea. 2/0 (2x70)	2 ea. 3/0 (2x95)	2 ea. 3/0 (2x95)
	350	1/0 (60)	2/0 (70)	3/0 (95)	4/0 (120)	2 ea. 2/0 (2x70)	2 ea. 3/0 (2x95)	2 ea. 3/0 (2x95)	2 ea. 4/0 (2x120)
	400	1/0 (60)	2/0 (70)	3/0 (95)	4/0 (120)	2 ea. 2/0 (2x70)	2 ea. 3/0 (2x95)	2 ea. 4/0 (2x120)	2 ea. 4/0 (2x120)
500	2/0 (70)	3/0 (95)	4/0 (120)	2 ea. 2/0 (2x70)	2 ea. 3/0 (2x95)	2 ea. 4/0 (2x120)	3 ea. 3/0 (3x95)	3 ea. 3/0 (3x95)	

* This chart is a general guideline and may not suit all applications. If cable overheating occurs, use next size larger cable.

**Weld cable size (AWG) is based on either a 4 volts or less drop or a current density of at least 300 circular mils per ampere.
 () = mm² for metric use

S-0007-F

***For distances longer than those shown in this guide, call a factory applications representative at 1-800-332-3281.

SECTION 6 – OPERATING THE WELDING GENERATOR

NOTE

If the unit is extremely overloaded, weld and generator power will stop. Turn unit off and restart to reset the generator protection circuit and restore weld generator power output.

If the rated output of the unit is exceeded, engine speed may vary rapidly until the weld or generator load is reduced.

6-1. Front Panel Controls

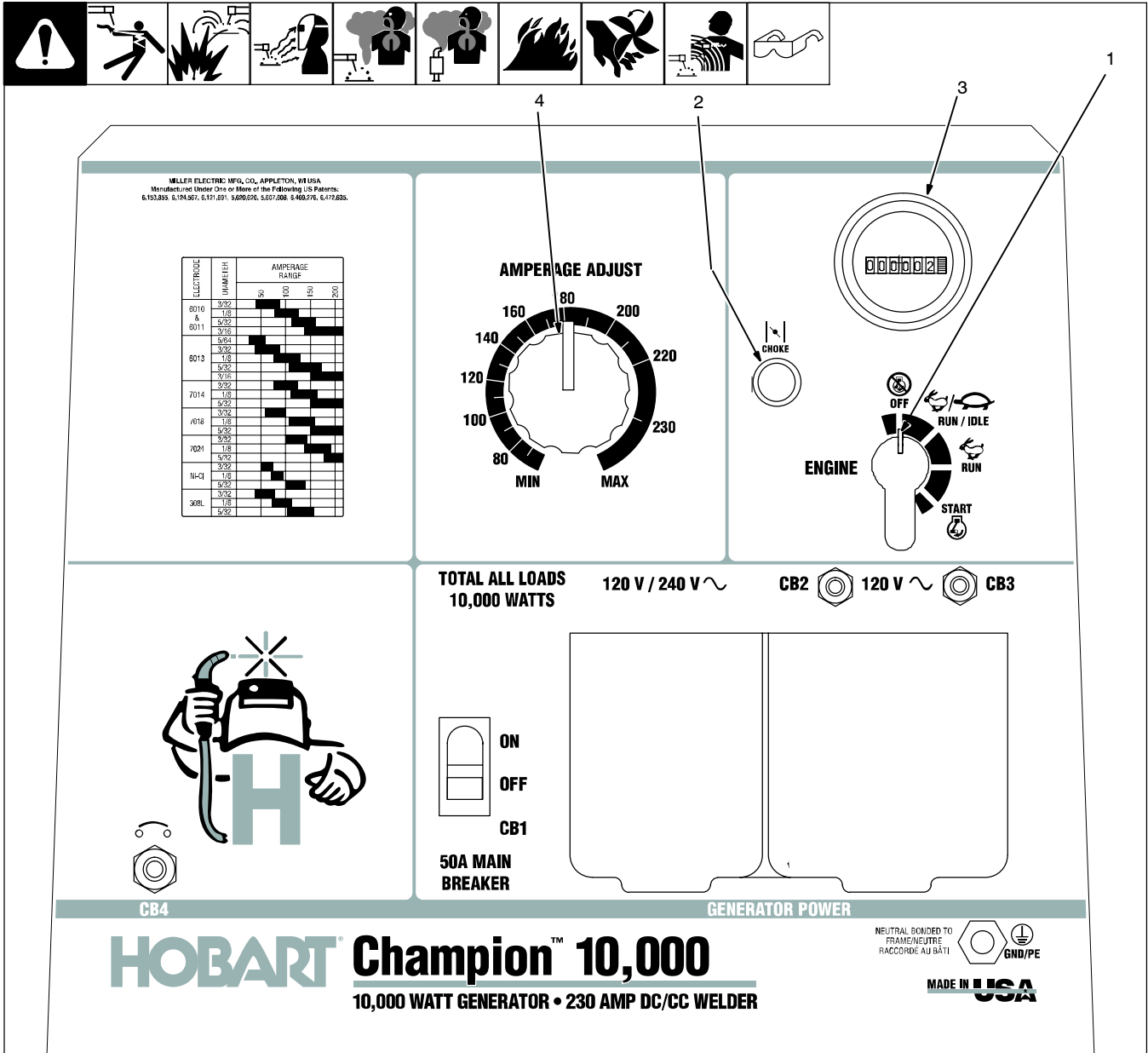

MILLER ELECTRIC MFG. CO., APPLETON, WI USA
Manufactured Under One or More of the Following US Patents:
6,153,809; 6,124,957; 6,171,051; 5,600,026; 5,077,008; 4,466,576; 6,177,625.

ELECTRODE	DIAMETER	AMPERAGE RANGE			
		50	100	150	200
8010 & 8011	3/32				
	1/8				
8013	3/32				
	1/8				
7014	3/32				
	1/8				
A016	3/32				
	1/8				
7021	3/32				
	1/8				
N-C1	3/32				
	1/8				
308L	3/32				
	1/8				

AMPERAGE ADJUST

MIN 80 100 120 140 160 80 200 220 230 MAX

ENGINE

OFF RUN / IDLE RUN START

CHOKER

1 Engine Control Switch

2 Engine Choke Control

3 Engine Hour Meter

4 Amperage Control

TOTAL ALL LOADS 10,000 WATTS

120 V / 240 V ~

CB2 120 V ~ CB3

50A MAIN BREAKER

ON

OFF

CB1

GENERATOR POWER

NEUTRAL BONDED TO FRAME/NEUTRE RACCORDÉ AU BÂTI

GND/PE

MADE IN USA

HOBART Champion™ 10,000

10,000 WATT GENERATOR • 230 AMP DC/CC WELDER

Ref.226 427-A

1 Engine Control Switch

Use switch to start engine, select speed, and stop engine. In Run/Idle position, engine runs at idle speed at no load, and weld/power speed under load. In Run position, engine runs at weld/power speed.

2 Engine Choke Control

Use control to change engine air-fuel mix.

To Start: pull out choke and turn Engine Control switch to Start position. Release switch and slowly push choke in when engine starts.

 If the engine does not start, let the engine come to a complete stop before attempting restart.

 During cold weather some gasoline engines encounter difficulties that are easily remedied. See Section 6-2 and 10-1.

To Stop: turn Engine Control switch to Off position.

3 Engine Hour Meter

4 Amperage Control

Use control to select weld amperage. Select amperage according to electrode being used (see Section 6-3). Control may be adjusted while welding. Control does not affect generator power output.

6-2. Cold Weather Engine Operation

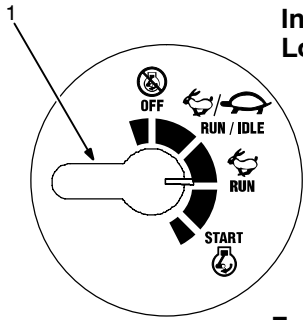

Infrequently Loaded

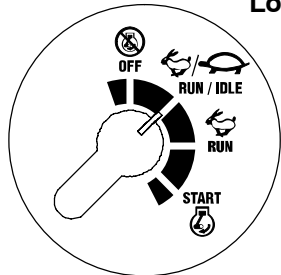

Frequently Loaded

Ref. 226 427-A

1 Engine Control Switch

Carburetor Icing

Carburetor icing causes the unit to drop below the normal idle speed and then stall. This condition occurs when the temperature is near freezing and the relative humidity is high. Ice forms on the throttle plate and inner bore of the carburetor. The engine typically restarts without problems but soon stalls again.

- Treat gasoline with a fuel de-icer product (isopropyl alcohol).
- Place the Engine Control switch in the Run position.
- Run engine only when expecting to frequently load it.

Breather Icing

Oil breather/pulse line icing occurs in severe cold (continuously below 0°F). Moisture accumulates in the oil from piston ring blow-by if the engine is extensively idled. This may cause vacuum line freezing, oil breather tube freezing or ice in the carburetor. All of these cause operating problems. Due to ice in the lines, the engine may not restart until it is warmed to above freezing.

- Load engine and reduce idle times to prevent engine shutdowns.
- Use an electric fuel pump to avoid pulse line freezing.
- Install engine cold-weather kit.

Both Kohler (1-800-544-2444) and Robin (1-800-277-6246) offer kits for cold weather operation. The user can install these kits. Both kits pull heated air from the muffler surface into the carburetor and shut the cold air off. This increases engine temperature during operation in both idle and high speed.

☞ When the ambient temperatures become warmer (above 45°F) the air flow will have to be returned to normal.

6-3. Amperage Selection Table For Stick (SMAW) Electrodes

☞ Use table on front panel to select correct amperage for the electrode being used.

ELECTRODE	DIAMETER	AMPERAGE RANGE			
		50	100	150	200
6010 & 6011	3/32				
	1/8				
	5/32				
	3/16				
6013	5/64				
	3/32				
	1/8				
	5/32				
	3/16				
7014	3/32				
	1/8				
	5/32				
7018	3/32				
	1/8				
	5/32				
7024	3/32				
	1/8				
	5/32				
Ni-CI	3/32				
	1/8				
	5/32				
308L	3/32				
	1/8				
	5/32				

Ref. 202 069-A

SECTION 7 – OPERATING AUXILIARY EQUIPMENT

NOTE

If the unit is extremely overloaded, weld and generator power will stop. Turn unit off and restart to reset the generator protection circuit and restore weld and generator power output.

If the rated output of the unit is exceeded, engine speed may vary rapidly until the weld or generator power load is reduced.

The welding generator provides power while welding and with the Amperage control in any position. However, under these conditions equipment connected to the welding generator may be subject to larger than normal voltage fluctuations. It is recommended that only lamps be powered under these conditions.

7-1. Standard Receptacles

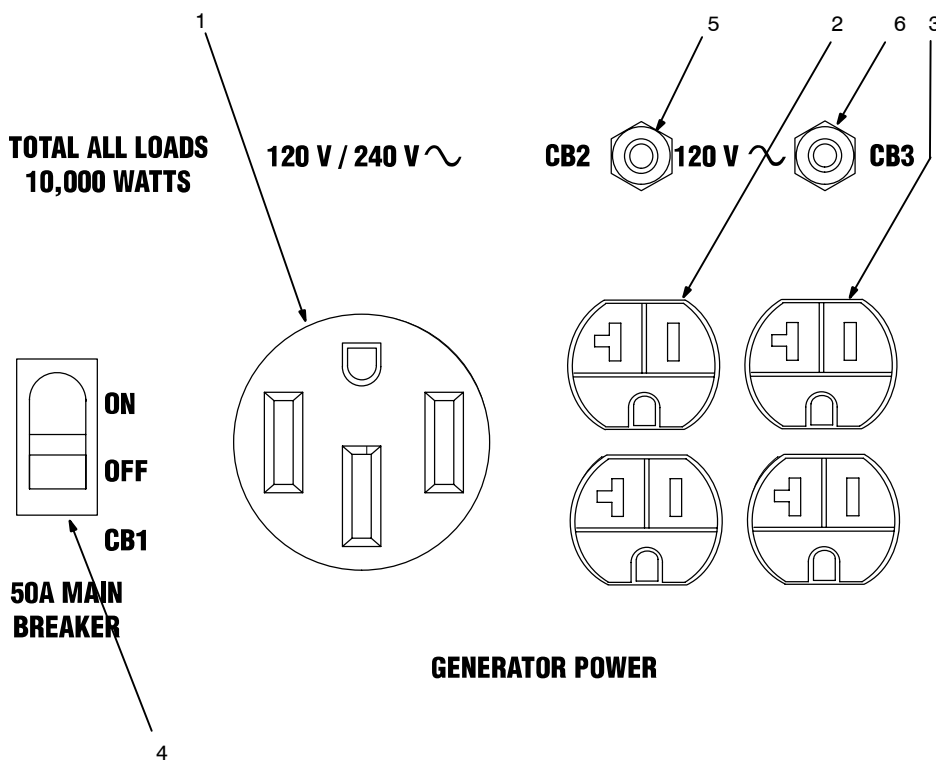

▲ If unit does not have GFCI receptacles, use GFCI-protected extension cord.

- 1 120/240 V 50 A AC Receptacle RC1

RC1 supplies 60 Hz single-phase power at weld/power speed. Maximum output is 10 kVA/kW.

- 2 120 V 20 A AC Duplex Receptacle RC2

- 3 120 V 20 A AC Duplex Receptacle RC3

RC2 and RC3 supply 60 Hz single-phase power at weld/power speed. Maximum output from RC2 or RC3 is 2.4 kVA/kW.

- 4 Supplementary Protector CB1

CB1 protects the ac receptacles from overload. If CB1 opens, the ac receptacles do not work.

 Move CB1 toggle switch to On position to reset. If supplementary protector continues to open, contact Factory Authorized Service Agent.

- 5 Supplementary Protector CB2

- 6 Supplementary Protector CB3

CB2 protects RC2 and CB3 protects RC3 from overload. If a supplementary protector opens, the receptacle does not work.

 Press button to reset. If supplementary protector continues to open, contact Factory Authorized Service Agent.

Combined output of all receptacles limited to 10 kVA/kW rating of the generator.

EXAMPLE: If 20 A is drawn from each 120 V duplex receptacle, only 21 A is available at the 240V receptacle:

$$2 \times (120 \text{ V} \times 20 \text{ A}) + (240 \text{ V} \times 21 \text{ A}) = 10 \text{ kVA/kW (approx.)}$$

7-3. Wiring Instructions For Optional 240 Volt, Single-Phase Plug (NEMA 14-50P)



Current Available in Amperes	
240 V Receptacle*	Each 120 V Duplex Receptacle
0	20
5	20
10	20
15	20
20	20
25	15
30	10
35	5
40	0

V x A = Watts

*One 240 V load or two 120 V loads.

The plug can be wired for a 240 V, 2-wire load or a 120/240V, 3-wire load. See circuit diagram.

1 Plug Wired for 120/240 V, 3-Wire Load

When wired for 120 V loads, each duplex receptacle shares a load with one half of 240 V receptacle.

2 Plug Wired for 240 V, 2-Wire Load

3 Neutral (Silver) Terminal

4 Load 1 (Brass) Terminal

5 Load 2 (Brass) Terminal

6 Ground (Green) Terminal

7 Amperes Available using 120/240 V Plug

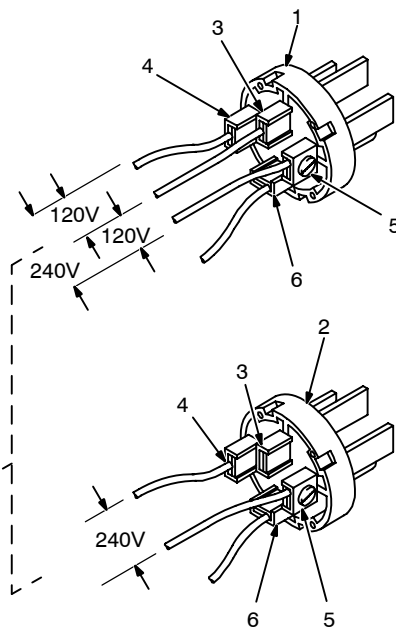

Tools Needed:

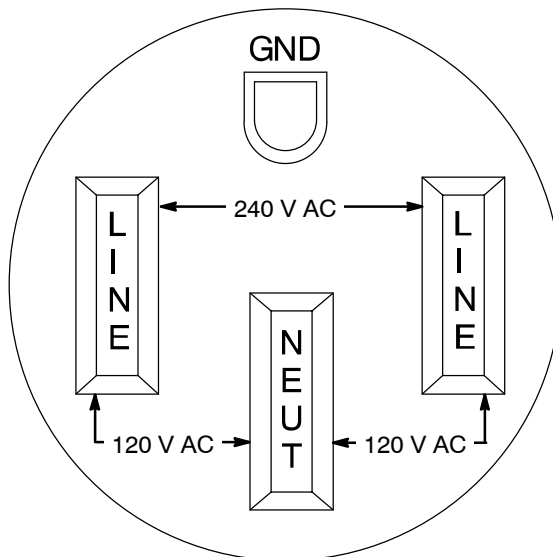
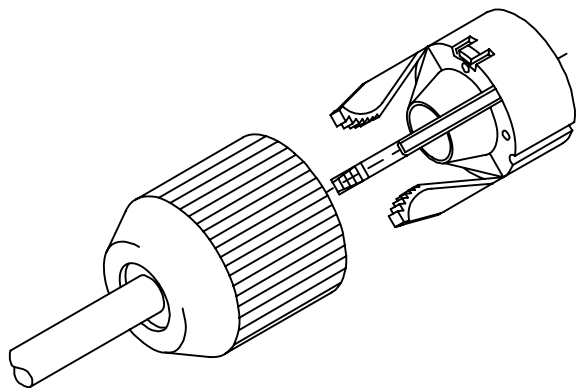
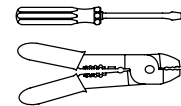

SECTION 8 – MAINTENANCE (ROBIN-POWERED UNITS)

8-1. Routine Maintenance (Robin-Powered Units)

								<p>Recycle engine fluids.</p> <p>▲ Stop engine before maintaining.</p> <p> See <i>Engine Manual and Maintenance Label</i> for important start-up, service, and storage information. Service engine more often if used in severe conditions.</p>
--	--	--	--	--	--	--	--	--

		✓ = Check ◇ = Change ● = Clean ☆ = Replace * To be done by Factory Authorized Service Agent				Reference			
Every 8 Hours		✓ Fuel Level		✓ Oil Level		● Oil, Fuel Spills	Section 5-2		
Every 20 Hours		✓ ● Spark Arrester Screen					Section 8-5		
Every 25 Hours		● Air Cleaner Wrapper					Section 8-3		
Every 50 Hours		● Weld Terminals							
Every 100 Hours		● Battery Terminals		● Cooling System		◇ Oil		✓ ☆ Air Cleaner Element	Engine Manual, Section 8-6, 8-3
Every 200 Hours		☆ Unreadable Labels		✓ Spark Plug Gap		◇ Oil Filter		☆ Fuel Filter	Engine Manual, Section 8-6
Every 500 Hours		✓ ☆ Weld Cables		✓ ● Slip Rings* ✓ ☆ Brushes*		✓ Valve Clearance*			Engine Manual
Every 1000 Hours		● Inside Unit							

8-2. Maintenance Label (Robin-Powered Units)

KOHLER CH20, ROBIN EH64/EH65 GAS ENGINES



See Engine Manual for complete engine care. Give Engine Specification and Serial Number when ordering parts.



Check Daily.

To Drain Oil:
Push And Turn CCW

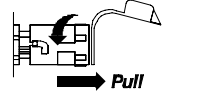

Pull

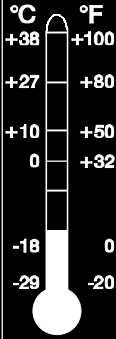
		KOHLER	ROBIN
	°C		
	+38		
	+27		
	+10		
	0		
	-18		
	°F		
+100	↑	10W-30	80
+80			
+50			
+32			
0			
-20			
		↓	↓
		5W-20, 5W-30	10W-30, 10W-40 5W-30

Recommended Oil
 API Service Classification . . . SG or higher
 (If using LP fuel, use synthetic oil.)

Oil Change 100 hours
 Oil Filter Change 200 hours
 Oil Filter **KOHLER:** MILLER 066 698, Kohler 1205001
ROBIN: MILLER 198 754, Robin 248-65801-00

Oil Capacity w/filter change . . . Approximately 1.5 quarts

DO NOT OVERFILL . . . KOHLER: Keep oil level between L & F marks on dipstick.
ROBIN: Keep oil level between 2 holes on dipstick.

NO SOBRELLENE . . . KOHLER: Mantenga el nivel del aceite entre las marcas L y F del medidor.
ROBIN: Mantenga el nivel del aceite entre los dos huecos del medidor.



Fuel Grade Unleaded, 87 Octane min.
Fuel Filter KOHLER: MILLER 215 984, Kohler 2505008
ROBIN: MILLER 215 984, Robin 263-65012-A3



Air Filter Service 100 hours – see Owner's Manual
Air Filter KOHLER: MILLER 067 272, Kohler 4708303
Air Filter Wrapper KOHLER: MILLER 067 273, Kohler 2408302
Air Filter ROBIN: MILLER 198 755, Robin 263-32610-A1
(Includes Air Filter Wrapper)



12 Volt Battery BCI Group 58
Cranking Performance at 0°F (-18°C) . . . 430 Amps min.



Engine Speed
No Load

High Speed . . . 3675-3750 RPM
 Idle 2200-2300 RPM
 Miller Legend. . See Owner's Manual

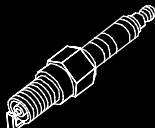

Spark Plug KOHLER: MILLER 067 007, Kohler 1213202,
 Champion RC-12YC
 Gap: 0.030 in. **ROBIN:** MILLER 198 777, Robin X65-01407-30,
 NGK BPR4EY
Use only resistor spark plugs and wires.

Tune-up and Filter Kit . . (Includes Air, Oil and Fuel Filters, and 2 Spark Plugs)
KOHLER: MILLER 180 096
ROBIN: MILLER 199 062

215 939-D

OM-945 Page 24

8-4. Overload Protection (Robin-Powered Units)



Tools Needed:

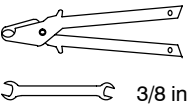

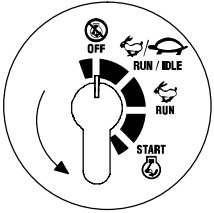

▲ Stop engine. Disconnect negative (-) battery cable.

☞ *If the unit is extremely overloaded, weld and generator power will stop. Turn unit off and re-start to reset the generator protection circuit and restore weld and generator power output.*

If the rated output of the unit is exceeded, engine speed may vary rapidly until the weld or generator power load is reduced.

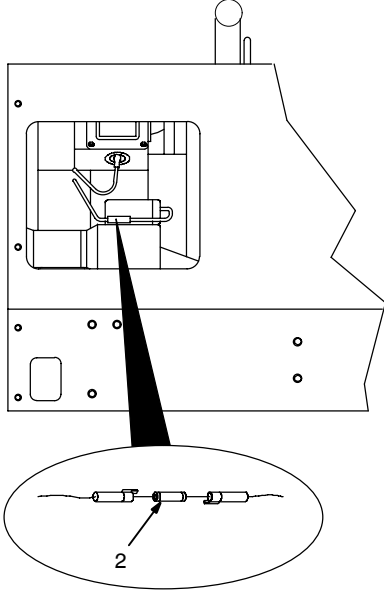

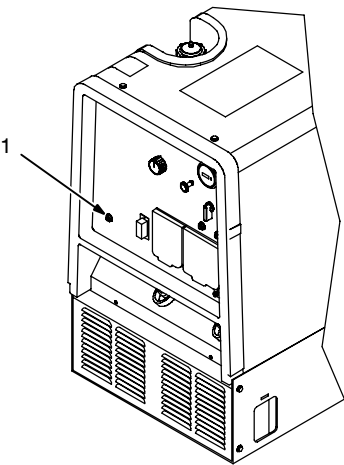

1 Circuit Breaker CB4 (See Parts List)

CB4 protects the generator excitation circuit. If CB4 opens, there is no/low weld and generator power output.

Press button to reset breaker.

2 Fuse F6 (See Parts List)

F6 protects the engine wiring system. If F6 opens, the engine does not crank. If F6 opens while the engine is running, the engine stops.

Replace fuse if open. Reinstall cover before operating.

☞ *If a fuse or circuit breaker opens, it usually indicates a more serious problem exists. Contact a Factory Authorized Service Agent.*

802 342 / Ref. 802 353-G

8-5. Servicing Optional Spark Arrestor (Robin-Powered Units)



Tools Needed:

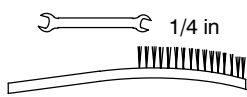

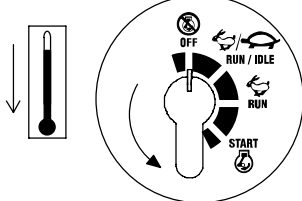

▲ Stop engine and let cool.

1 Spark Arrestor Screen

Clean and inspect screen. Replace spark arrestor if screen wires are broken or missing.

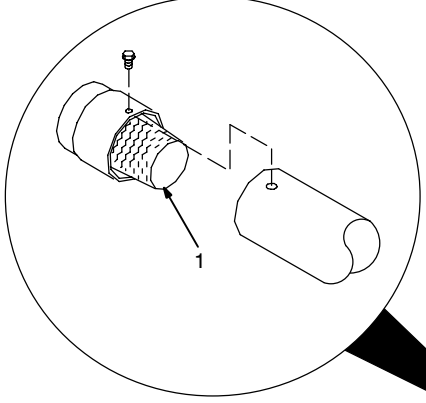

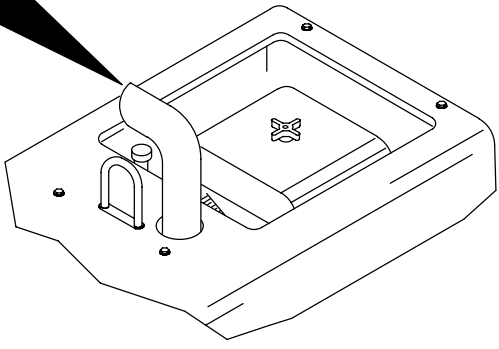

Ref. 801 682-A / Ref. 802 353-A

8-6. Changing Engine Oil, Oil Filter, and Fuel Filter (Robin-Powered Units)

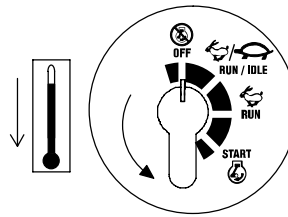

▲ Stop engine and let cool.

- 1 Oil Drain Valve
- 2 1/2 ID x 7 in Hose
- 3 Oil Filter

Change engine oil and filter according to engine owner's manual.

▲ Close valve and valve cap before adding oil and running engine.

Fill crankcase with new oil to full mark on dipstick (see Section 8-2).

- 4 Fuel Filter
- 5 Fuel Line

Replace line if cracked or worn. Install new filter. Wipe up any spilled fuel.

Start engine, and check for fuel leaks.

▲ Stop engine, tighten connections as necessary, and wipe up fuel.

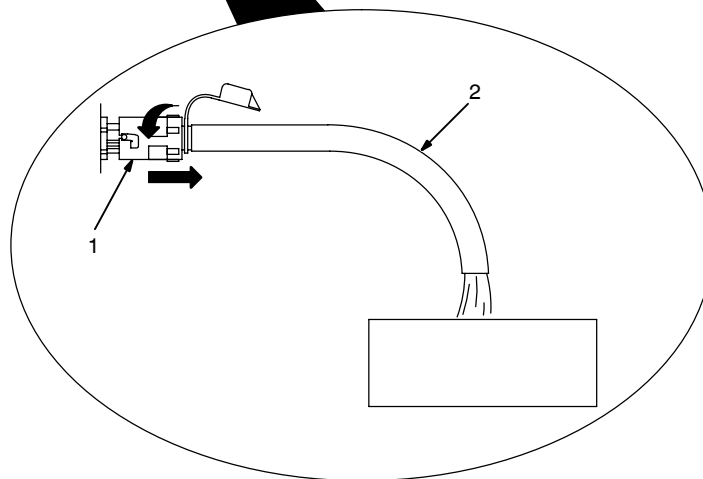
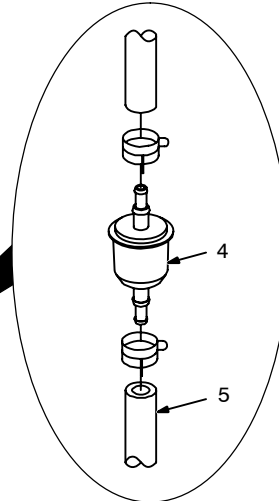
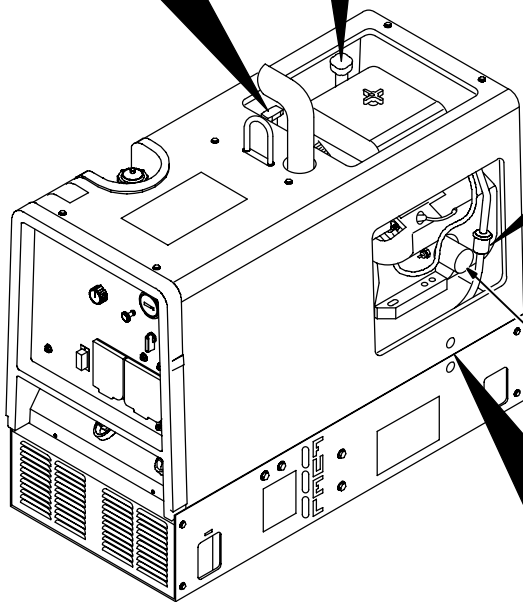
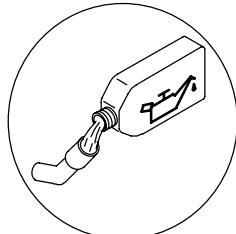
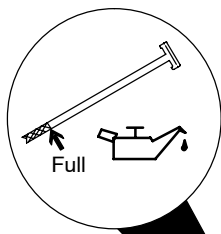

Tools Needed:

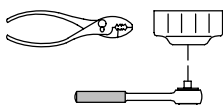

8-7. Adjusting Engine Speed (Robin-Powered Units)



	2200 ± 100 rpm
	3700 ± 50 rpm

After tuning engine, check engine speeds with a tachometer (see table). If necessary, adjust speeds as follows:

Start engine and run until warm.

Remove wrapper to access speed adjustments.

Idle Speed Adjustment

Move Engine Control switch to Run/Idle position.

- 1 Throttle Solenoid
- 2 Mounting Screws
- 3 Idle Speed Screw

Loosen mounting screws. Adjust solenoid position so engine runs at idle speed. If necessary, back out idle speed screw so solenoid can be moved to correct position. Tighten mounting screws. Be sure solenoid linkage works smoothly.

Turn idle speed screw for fine adjustments.

Weld/Power Speed Adjustment

Move Engine Control switch to Run position.

- 4 Jam Nut
- 5 Lock Nut
- 6 Weld/Power Speed Adjustment Screw

Loosen jam nut and lock nut. Turn adjustment screw until engine runs at weld/power speed. Tighten jam nut, and then tighten lock nut.

▲ Stop engine.

Reinstall wrapper.

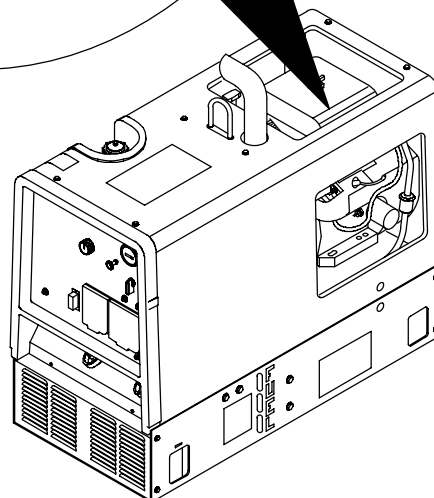
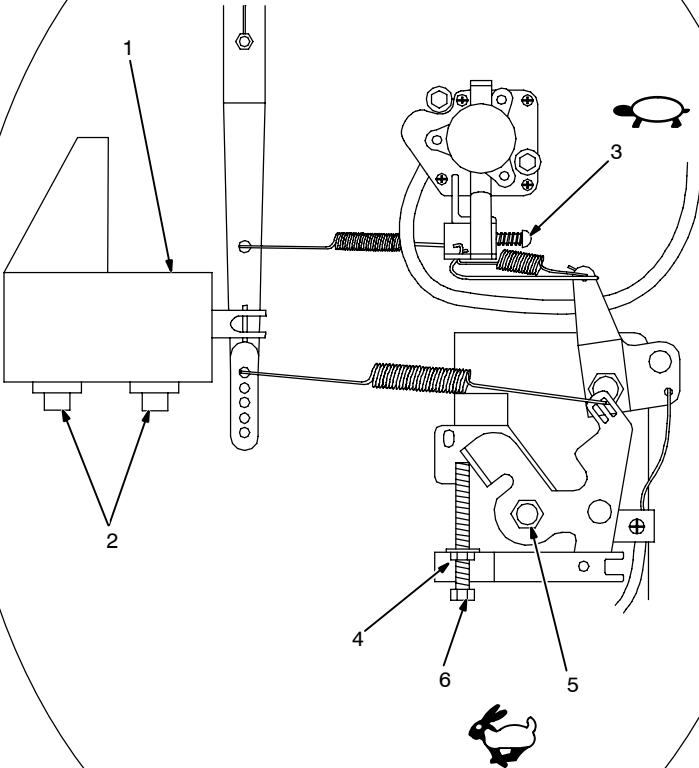

Tools Needed:

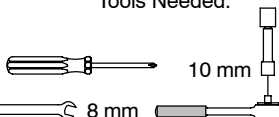

SECTION 9 – MAINTENANCE – (KOHLER-POWERED UNITS)

9-1. Routine Maintenance (Kohler-Powered Units)

							<p>Recycle engine fluids.</p> <p>▲ Stop engine before maintaining.</p> <p>☞ See <i>Engine Manual and Maintenance Label</i> for important start-up, service, and storage information. Service engine more often if used in severe conditions.</p>
--	--	--	--	--	--	--	---

		✓ = Check ◇ = Change ● = Clean * To be done by Factory Authorized Service Agent	☆ = Replace	Reference		
Every 8 Hours		✓ Fuel Level	 ✓ Oil Level	 ● Oil, Fuel Spills	Section 5-3	
Every 20 Hours		✓ ● Spark Arrester Screen			Section 9-5	
Every 25 Hours		● Air Cleaner Wrapper			Section 9-3	
Every 50 Hours		● Weld Terminals				
Every 100 Hours		● Battery Terminals	 ● Cooling System	 ◇ Oil	 ✓ ☆ Air Cleaner Element	Engine Manual, Section 9-3, 9-6
Every 200 Hours		☆ Unreadable Labels	 ✓ Spark Plug Gap	 ◇ Oil Filter	 ☆ Fuel Filter	Engine Manual, Section 9-6
Every 500 Hours		✓ ☆ Weld Cables	 ✓ ● Slip Rings* ✓ ☆ Brushes*			Engine Manual
Every 1000 Hours		● Inside Unit				

9-2. Maintenance Label (Kohler-Powered Units)

KOHLER CH20, ROBIN EH64/EH65 GAS ENGINES



See Engine Manual for complete engine care. Give Engine Specification and Serial Number when ordering parts.



Check Daily.

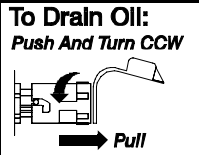

To Drain Oil:
Push And Turn CCW
Pull

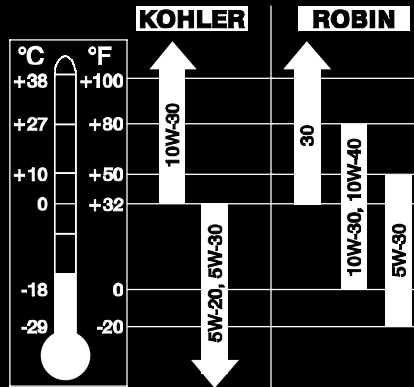

Recommended Oil

API Service Classification . . . SG or higher
(If using LP fuel, use synthetic oil.)

Oil Change 100 hours

Oil Filter Change 200 hours

Oil Filter **KOHLER:** MILLER 066 698, Kohler 1205001
ROBIN: MILLER 198 754, Robin 248-65801-00

Oil Capacity w/filter change . . Approximately 1.5 quarts

DO NOT OVERFILL . . **KOHLER:** Keep oil level between L & F marks on dipstick.
ROBIN: Keep oil level between 2 holes on dipstick.

NO SOBRELLENE . . . **KOHLER:** Mantenga el nivel del aceite entre las marcas L y F del medidor.
ROBIN: Mantenga el nivel del aceite entre los dos huecos del medidor.



Gasoline

Fuel Grade Unleaded, 87 Octane mln.

Fuel Filter **KOHLER:** MILLER 215 984, Kohler 2505008
ROBIN: MILLER 215 984, Robin 263-65012-A3



Air Filter Service 100 hours – see Owner’s Manual

Air Filter **KOHLER:** MILLER 067 272, Kohler 4708303

Air Filter Wrapper **KOHLER:** MILLER 067 273, Kohler 2408302

Air Filter **ROBIN:** MILLER 198 755, Robin 263-32610-A1
(Includes Air Filter Wrapper)



12 Volt Battery BCI Group 58

Cranking Performance at 0°F (-18°C) . . . 430 Amps mln.



Engine Speed High Speed . . . 3675-3750 RPM

No Load Idle 2200-2300 RPM

Miller Legend. . See Owner’s Manual

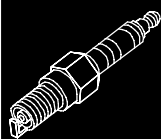

Spark Plug **KOHLER:** MILLER 067 007, Kohler 1213202,
Champion RC-12YC

Gap: 0.030 In. **ROBIN:** MILLER 198 777, Robin X65-01407-30,
NGK BPR4EY

Use only resistor spark plugs and wires.

Tune-up and Filter Kit . . (Includes Air, Oil and Fuel Filters, and 2 Spark Plugs)

KOHLER: MILLER 180 096

ROBIN: MILLER 199 062

215 939-D

9-3. Servicing Air Cleaner (Kohler-Powered Units)

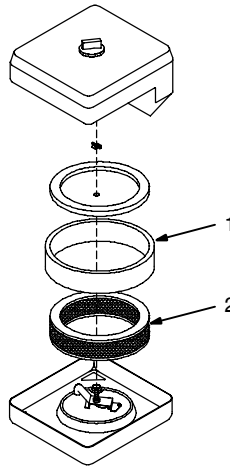
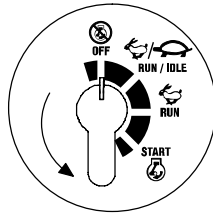

- ▲ Stop engine.
- ▲ Do not run engine without air cleaner or with dirty element.

1 Wrapper

Wash wrapper with soap and water solution. Allow wrapper to air dry completely.

Spread 1 tablespoon SAE 30 oil evenly into wrapper. Squeeze out excess oil.

2 Element

Replace element if damaged, dirty, or oily.

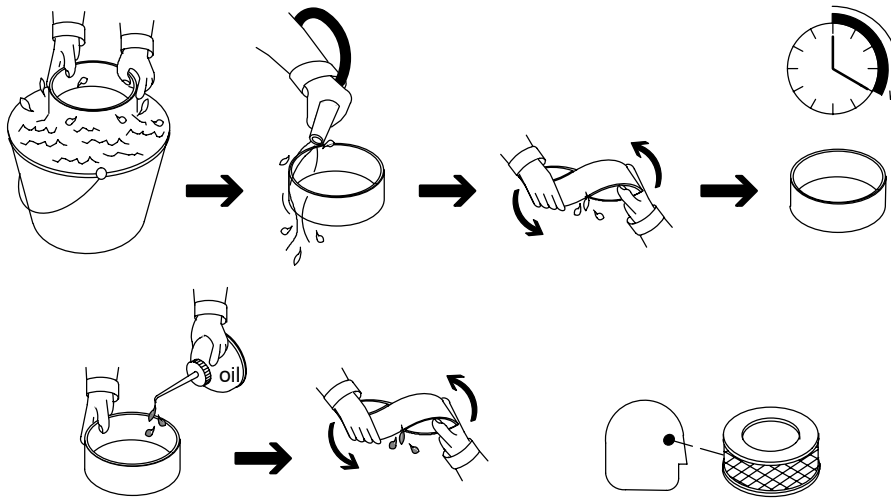

aircleaner3 11/04 - 802 772 / S-0759

Notes



HOBART INSTITUTE OF WELDING TECHNOLOGY

400 Trade Square East, Troy, Ohio 45373
1-800-332-9448 www.welding.org

**Start Your Professional
Welding Career Now!**

**Over 80,000 trained
since 1930!**

9-4. Overload Protection (Kohler-Powered Units)



Tools Needed:

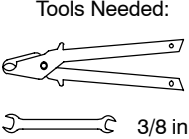

3/8 in

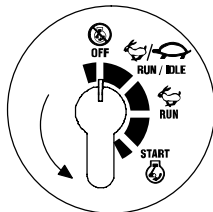

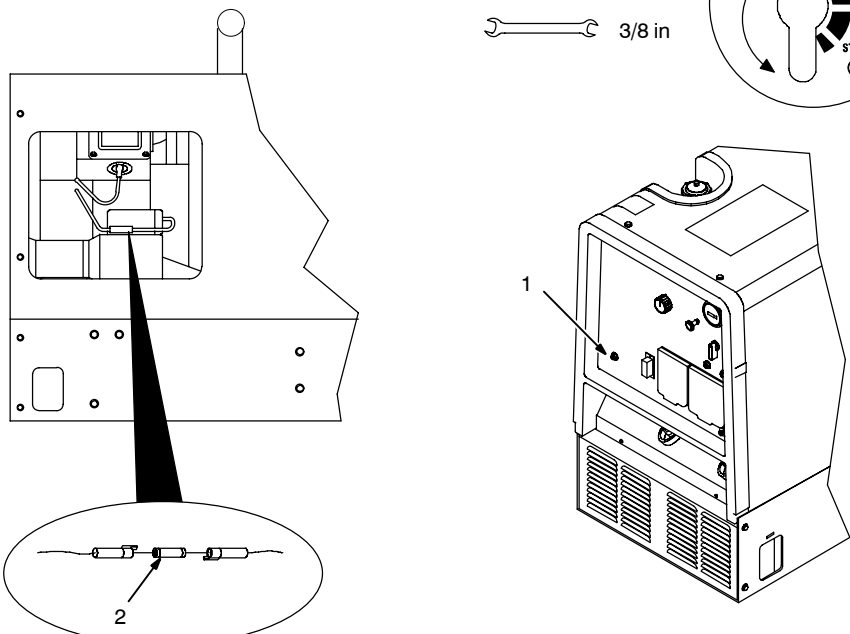

▲ Stop engine.

☞ *If the unit is extremely overloaded, weld and generator power will stop. Turn unit off and restart to reset the generator protection circuit and restore weld and generator power output.*

If the rated output of the unit is exceeded, engine speed may vary rapidly until the weld or generator power load is reduced.

- 1 Circuit Breaker CB4 (See Parts List)

CB4 protects the generator excitation circuit. If CB4 opens, there will be no/low weld and generator power output.

Press button to reset breaker.

- 2 Fuse F6 (See Parts List)

F6 protects the engine wiring harness. If F6 opens, the engine does not crank. If F6 opens while the engine is running, the engine stops.

Replace fuse if open. Reinstall panel before operating unit.

☞ *If a fuse or circuit breaker opens, it usually indicates a more serious problem exists. Contact a Factory Authorized Service Agent.*

Ref. 801 221-B / Ref. 802 353-G

9-5. Servicing Optional Spark Arrestor (Kohler-Powered Units)



Tools Needed:

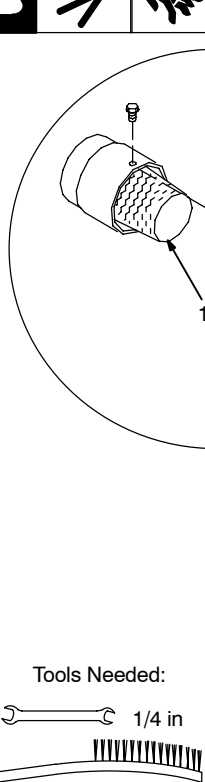

1/4 in

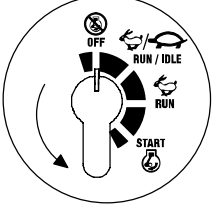

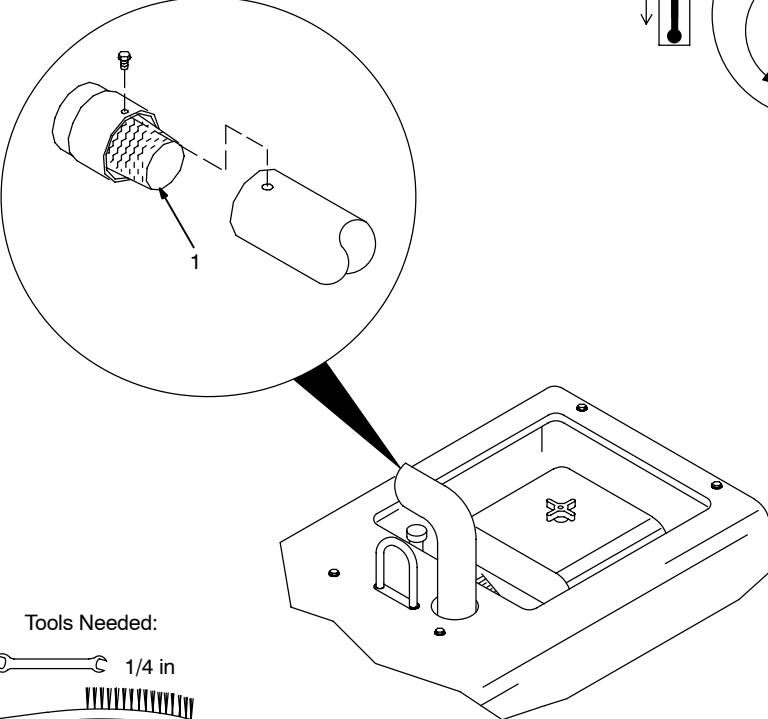

▲ Stop engine and let cool.

- 1 Spark Arrestor Screen

Clean and inspect screen. Replace spark arrestor if screen wires are broken or missing.

Ref. 801 695-A / Ref. 802 339-A

9-6. Changing Engine Oil, Oil Filter, and Fuel Filter (Kohler-Powered Units)

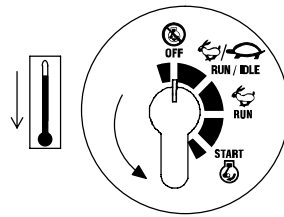

▲ Stop engine and let cool.

- 1 Oil Drain Valve
- 2 1/2 ID x 7 in Hose
- 3 Oil Filter

Change engine oil and filter according to engine owner's manual.

▲ Close valve and valve cap before adding oil and running engine.

Fill crankcase with new oil to full mark on dipstick (see Section 9-2).

- 4 Fuel Filter
- 5 Fuel Line

Replace line if cracked or worn. Install new filter. Wipe up any spilled fuel.

Start engine, and check for fuel leaks.

▲ Stop engine, tighten connections as necessary, and wipe up fuel.

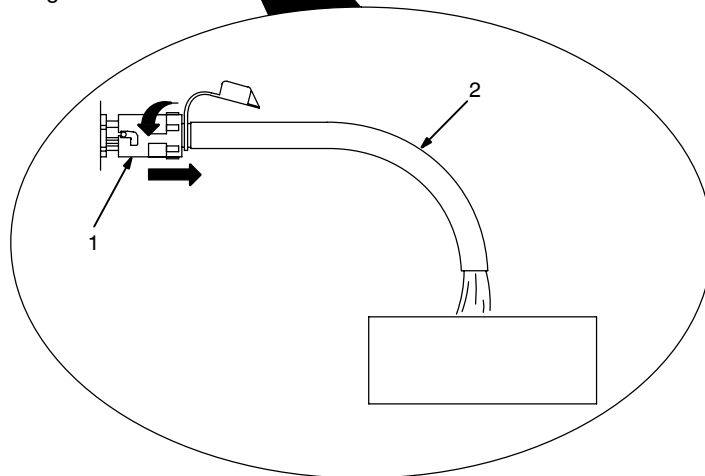
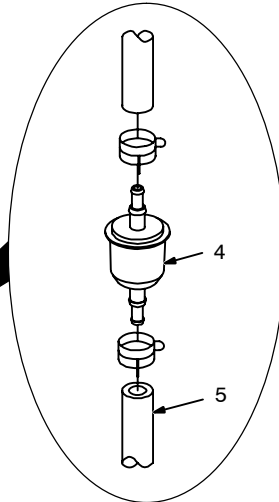
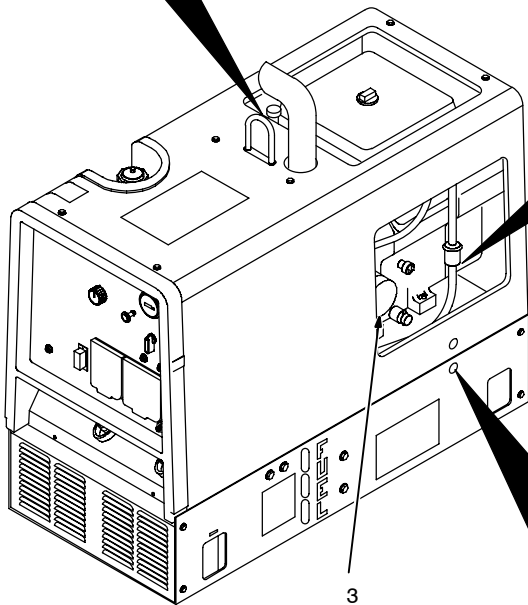
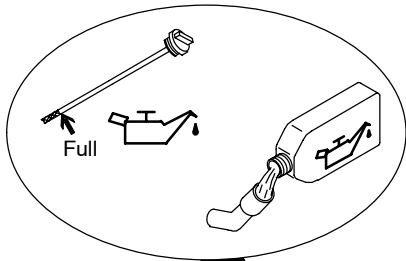

Tools Needed:

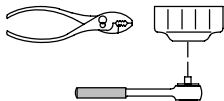

9-7. Adjusting Engine Speed (Kohler-Powered Units)

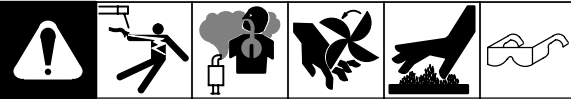

	2200 ± 50 rpm
	3700 ± 50 rpm

After tuning engine, check engine speeds with a tachometer (see table). If necessary, adjust speeds as follows:

Start engine and run until warm.

Remove wrapper to access speed adjustments.

Idle Speed Adjustment

Move Engine Control switch to Run/Idle position.

- 1 Throttle Solenoid
- 2 Mounting Screws
- 3 Idle Speed Screw

Loosen mounting screws. Adjust solenoid position so engine runs at idle speed. If necessary, back out idle speed screw so solenoid can be moved to correct position. Tighten mounting screws. Be sure solenoid linkage works smoothly.

Turn idle speed screw for fine adjustments.

Weld/Power Speed Adjustment

Move Engine Control switch to Run position.

- 4 Weld/Power Speed Adjustment Nut
- 5 Lock Nut

Loosen lock nut. Turn adjustment nut until engine runs at weld/power speed. Tighten lock nut.

▲ Stop engine.

Reinstall wrapper.

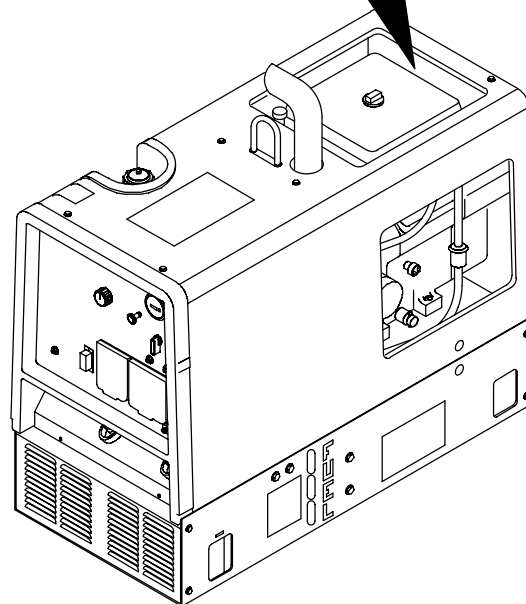
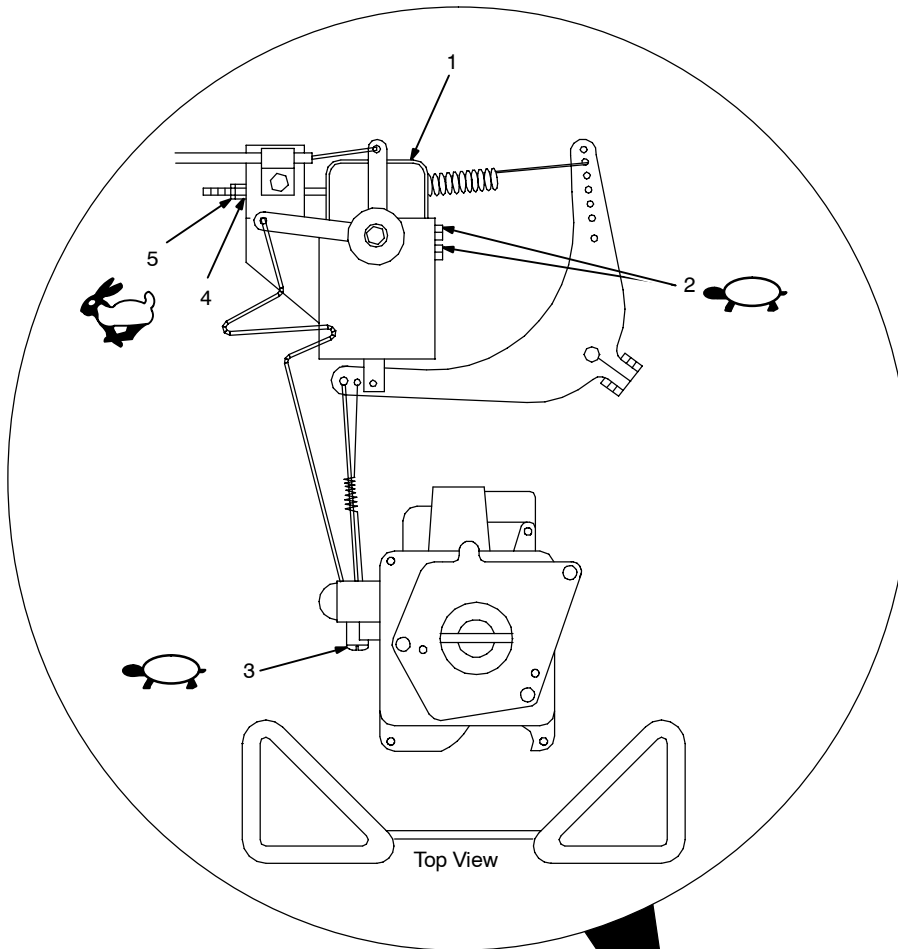

Tools Needed:

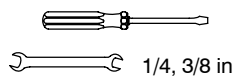

1/4, 3/8 in

802 339-G / 801 209-A

SECTION 10 – TROUBLESHOOTING

10-1. Troubleshooting

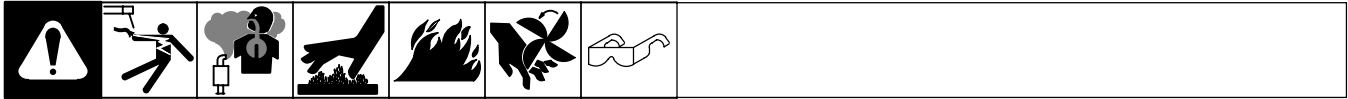

A. Welding

Trouble	Remedy
No weld output.	Check control settings.
	Check weld connections.
	Reset circuit breaker CB4 (see Section 8-4 or 9-4).
	Unit overloaded. Stop unit and reduce load. Restart unit to reset generator protection circuit and resume operation.
	Be sure all equipment is disconnected from receptacles when starting unit.
	Check plug PLG6 connection.
	Have Factory Authorized Service Agent check brushes, slip rings, integrated rectifier SR2 and field control board PC1.
Low weld output.	Reset circuit breaker CB4 (see Section 8-4 or 9-4).
	Check control settings.
	Check engine speed, and adjust if necessary (see Section 8-7 or 9-7).
	Service air cleaner according to engine manual.
	Have Factory Authorized Service Agent check brushes and slip rings and field control board PC1.
High weld output.	Check control settings.
	Check engine speed, and adjust if necessary (see Section 8-7 or 9-7).
Erratic weld output.	Check control settings.
	Tighten and clean connections to electrode and workpiece.
	Use dry, properly-stored electrodes for Stick and TIG welding.
	Remove excessive coils from weld cables.
	Clean and tighten connections both inside and outside welding generator.
	Check engine speed, and adjust if necessary (see Section 8-7 or 9-7).
	Have Factory Authorized Service Agent check brushes and slip rings.

B. Generator Power

Trouble	Remedy
No output at generator power ac receptacles.	Reset supplementary protectors (see Section 7-1 or 7-2).
	Press optional GFCI receptacle Reset button (see Section 7-2).
	Reset circuit breaker CB4 (see Section 8-4 or 9-4).
	Unit overloaded. Stop unit and reduce load. Restart unit to reset generator protection circuit and resume operation.
	Check plug PLG6 connection.
	Have Factory Authorized Service Agent check brushes, slip rings, integrated rectifier SR2 and field control board PC1.
High power output at generator power ac receptacles.	Check engine speed, and adjust if necessary (see Section 8-7 or 9-7).
Low power output at generator power ac receptacles.	Reset circuit breaker CB4 (see Section 8-4 or 9-4).
	Check engine speed, and adjust if necessary (see Section 8-7 or 9-7).

Trouble	Remedy
Erratic power output at generator power ac receptacles.	Check fuel level.
	Check engine speed and adjust if necessary (see Section 8-7 or 9-7).
	Check receptacle wiring and connections.
	Have Factory Authorized Service Agent check brushes and slip rings.

C. Engine

Trouble	Remedy
Engine will not crank.	Check fuse F6, and replace if open (see Section 8-4 or 9-4).
	Check battery voltage.
	Check battery connections and tighten if necessary.
	Check plug PLG4 and plug PLG8 connections.
	Have Factory Authorized Service Agent check Engine Control switch S2.
Engine will not start.	Check fuel level.
	Check battery voltage.
	Check battery connections and tighten if necessary.
	Check oil level (see Section 5-2 or 5-3).
	Check low oil pressure shutdown switch (see Parts List for location).
Have Factory Authorized Service Agent check fuel shutoff solenoid FS1.	
Engine starts, but stops when Engine Control switch returns to Run position.	Check oil level.
	Check and refill crankcase with proper viscosity oil for operating temperature, if necessary.
	Check low oil pressure shutdown switch (see Parts List for location).
Engine stopped during normal operation.	Check fuel level.
	Check oil level (see Section 5-2 or 5-3).
	Check fuse F6, and replace if open (see Section 8-4 or 9-4).
	Check low oil pressure shutdown switch (see Parts List for location).
	Periodically recharge battery (approximately every 3 months).
	Replace battery.
	Check voltage regulator and connections according to engine manual.
Have Factory Authorized Service Agent check fuel shutoff solenoid FS1.	
Battery Discharges between uses.	Clean battery, terminals, and posts with baking soda and water solution; rinse with clear water.
	Periodically recharge battery (approximately every 3 months).
	Replace battery.
	Check voltage regulator and connections according to engine manual.
Engine idles, but does not come up to weld speed.	Have Factory Authorized Service Agent check field control board PC1, and current transformer CT1.
Engine speed varies rapidly under heavy generator power load.	Reduce generator power load at ac receptacles.
Unstable or sluggish engine speeds.	Readjust throttle linkage if necessary. Check throttle solenoid TS1 for smooth operation.
	Check oil level. Oil level should not exceed Full mark on dipstick. Fuel pump will operate erratically if crankcase is overfilled.
	Tune-up engine according to engine manual.
Engine does not return to idle speed.	Remove weld and generator power loads.
	Check throttle linkage for smooth, non-binding operation.
	Have Factory Authorized Service Agent check current transformer CT1, Engine Control switch S2, throttle solenoid TS1, and field control board PC1.

SECTION 11 - ELECTRICAL DIAGRAM

⚠ WARNING

- Do not touch live electrical parts.
- Disconnect input power or stop engine before servicing.
- Do not operate with covers removed.
- Have only qualified persons install, use, or service this unit.

ELECTRIC SHOCK HAZARD

(POSITION)

S2	1	2	3	4	5	6
RUN/IDLE	X	X	X	X	X	X
RUN						
START						

(TERMINAL)

A	B	C	D	E	F
1T	O	O	O	O	O
33	53	60	60	51	
33					

X = CLOSED TO "B" TERMINAL

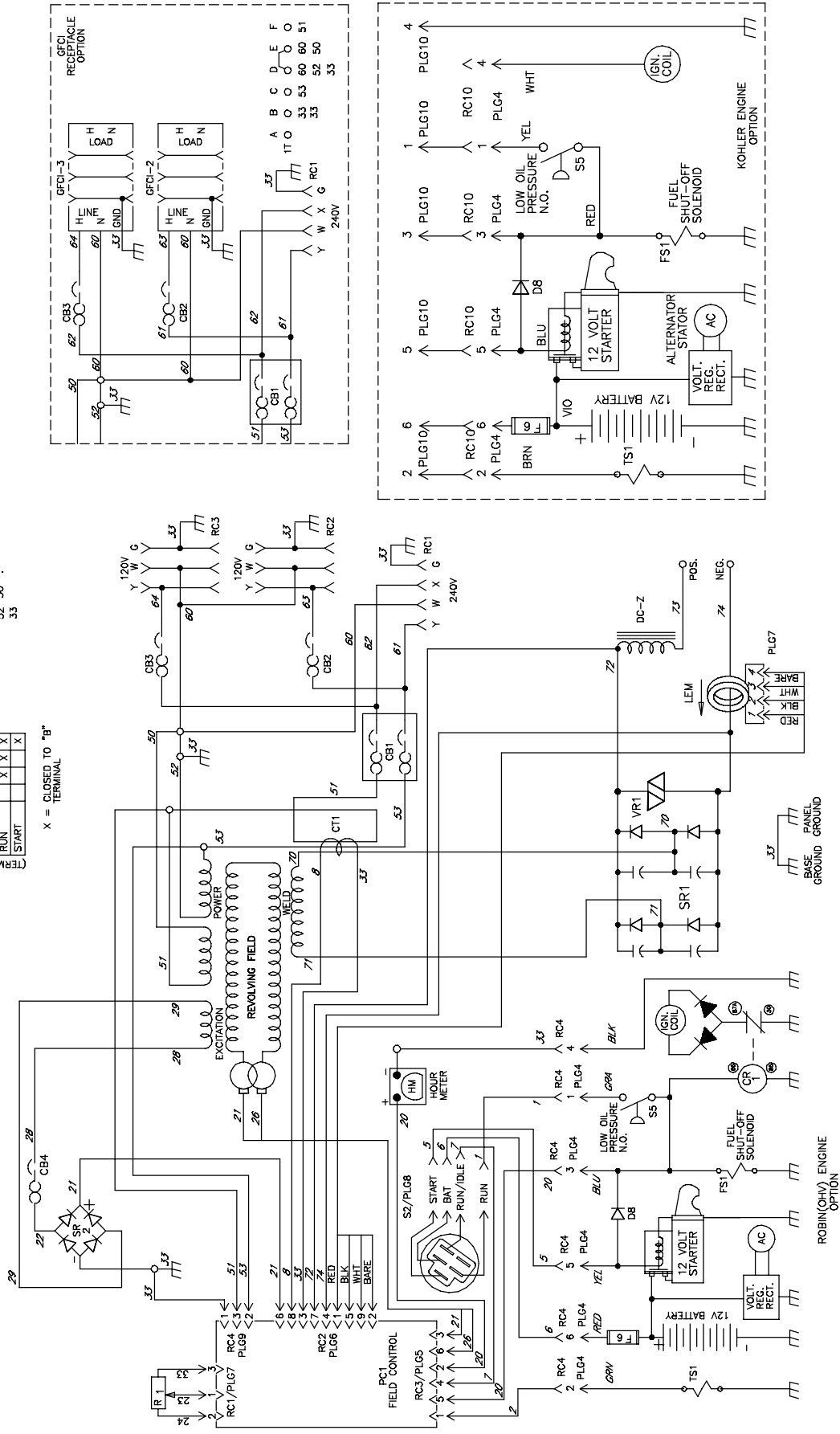

Figure 11-1. Circuit Diagram For Welding Generator (Robin And Kohler-Powered Units)

SECTION 12 – GENERATOR POWER GUIDELINES

NOTE

The views in this section are intended to be representative of all engine-driven welding generators. Your unit may differ from those shown.

12-1. Selecting Equipment

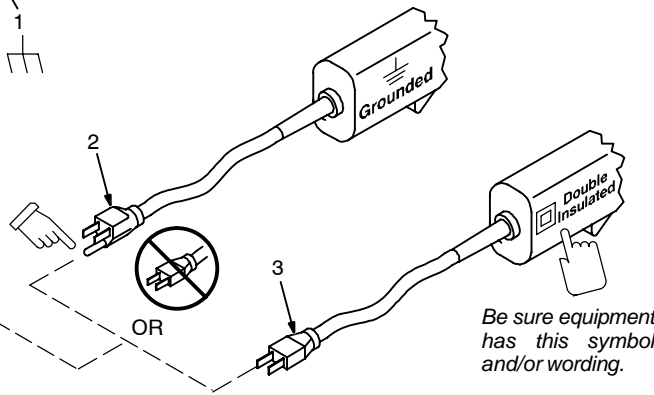
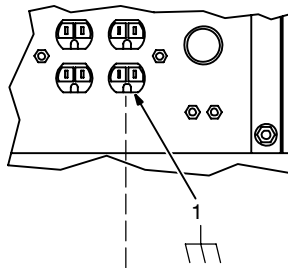

- 1 Generator Power Receptacles – Neutral Bonded To Frame
 - 2 3-Prong Plug From Case Grounded Equipment
 - 3 2-Prong Plug From Double Insulated Equipment
- ▲ **Do not use 2-prong plug unless equipment is double insulated.**

gen_pwr 11/02 – Ref. ST-159 730 / ST-800 577

12-2. Grounding Generator To Truck Or Trailer Frame

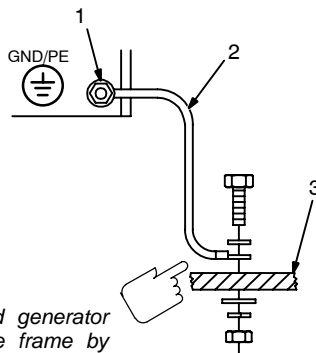
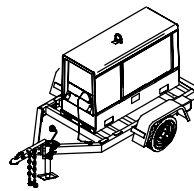
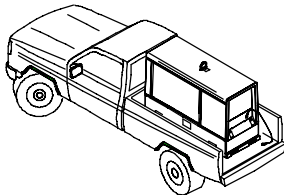

Electrically bond generator frame to vehicle frame by metal-to-metal contact.

- ▲ **Bed liners, shipping skids, and some running gear insulate the welding generator from the vehicle frame. Always connect a ground wire from the generator equipment grounding terminal to bare metal on the vehicle frame as shown.**

- ▲ **Always ground generator frame to vehicle frame to prevent electric shock and static electricity hazards.**

- 1 Equipment Grounding Terminal (On Front Panel)
- 2 Grounding Cable (Not Supplied)
- 3 Metal Vehicle Frame

Connect cable from equipment ground terminal to metal vehicle frame. Use #10 AWG or larger insulated copper wire.

- ▲ **If unit does not have GFCI receptacles, use GFCI-protected extension cord.**

S-0854

12-3. Grounding When Supplying Building Systems

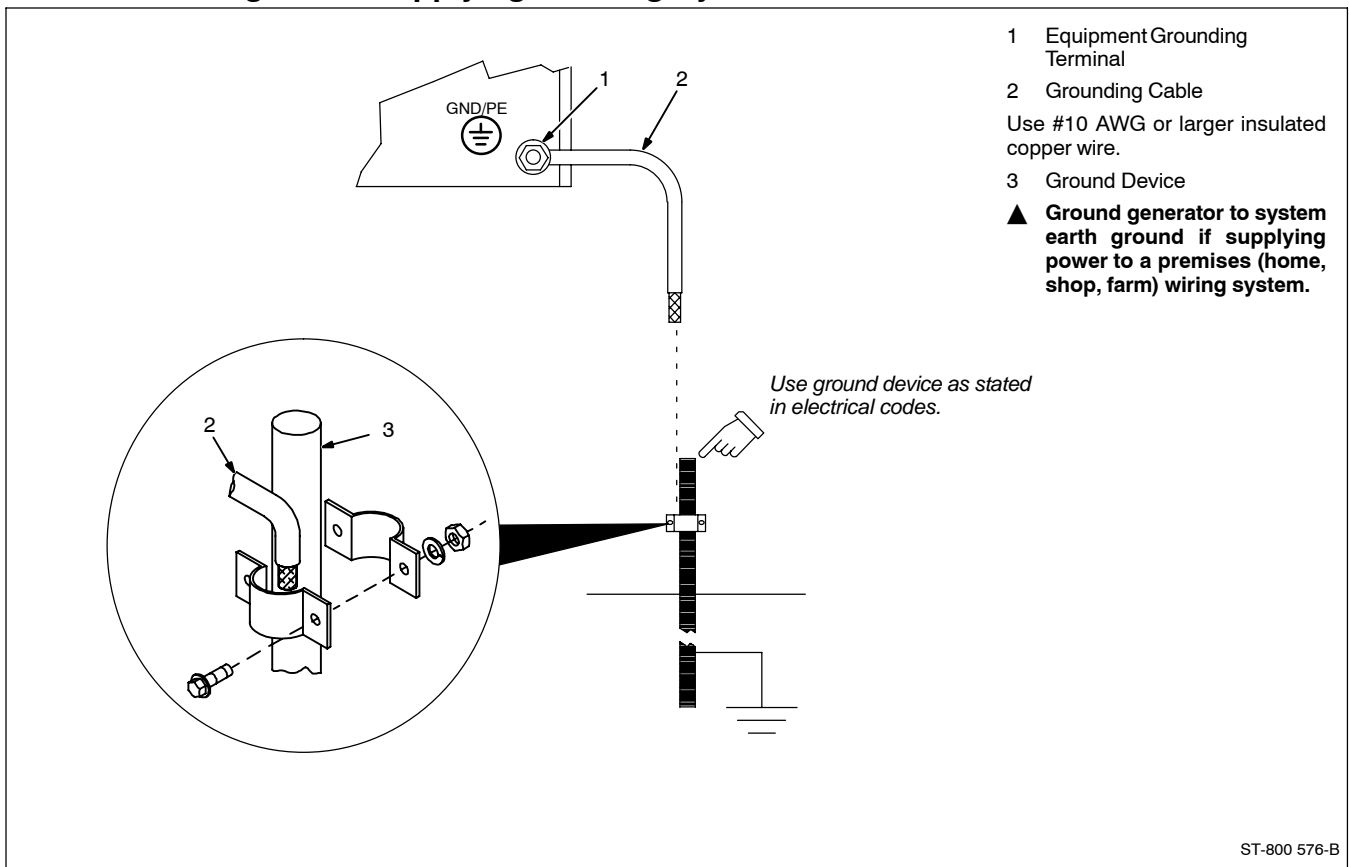

12-4. How Much Power Does Equipment Require?

1 Resistive Load
 A light bulb is a resistive load and requires a constant amount of power.

2 Non-Resistive Load
 Equipment with a motor is a non-resistive load and requires approximately six times more power while starting the motor than when running (see Section 12-8).

3 Rating Data
 Rating shows volts and amperes, or watts required to run equipment.

AMPERES x VOLTS = WATTS

EXAMPLE 1: If a drill uses 4.5 amperes at 115 volts, calculate its running power requirement in watts.

$4.5 \text{ A} \times 115 \text{ V} = 520 \text{ W}$

The load applied by the drill is 520 watts.

EXAMPLE 2: If three 200 watt flood lamps are used with the drill from Example 1, add the individual loads to calculate total load.

$(200 \text{ W} + 200 \text{ W} + 200 \text{ W}) + 520 \text{ W} = 1120 \text{ W}$

The total load applied by the three flood lamps and drill is 1120 watts.

S-0623

12-5. Approximate Power Requirements For Industrial Motors

Industrial Motors	Rating	Starting Watts	Running Watts
Split Phase	1/8 HP	800	300
	1/6 HP	1225	500
	1/4 HP	1600	600
	1/3 HP	2100	700
	1/2 HP	3175	875
Capacitor Start-Induction Run	1/3 HP	2020	720
	1/2 HP	3075	975
	3/4 HP	4500	1400
	1 HP	6100	1600
	1-1/2 HP	8200	2200
	2 HP	10550	2850
	3 HP	15900	3900
Capacitor Start-Capacitor Run	5 HP	23300	6800
	1-1/2 HP	8100	2000
	5 HP	23300	6000
	7-1/2 HP	35000	8000
Fan Duty	10 HP	46700	10700
	1/8 HP	1000	400
	1/6 HP	1400	550
	1/4 HP	1850	650
	1/3 HP	2400	800
	1/2 HP	3500	1100

12-6. Approximate Power Requirements For Farm/Home Equipment

Farm/Home Equipment	Rating	Starting Watts	Running Watts
Stock Tank De-Icer		1000	1000
Grain Cleaner	1/4 HP	1650	650
Portable Conveyor	1/2 HP	3400	1000
Grain Elevator	3/4 HP	4400	1400
Milk Cooler		2900	1100
Milker (Vacuum Pump)	2 HP	10500	2800
FARM DUTY MOTORS	1/3 HP	1720	720
Std. (e.g. Conveyors,	1/2 HP	2575	975
Feed Augers, Air	3/4 HP	4500	1400
Compressors)	1 HP	6100	1600
	1-1/2 HP	8200	2200
	2 HP	10550	2850
	3 HP	15900	3900
	5 HP	23300	6800
High Torque (e.g. Barn	1-1/2 HP	8100	2000
Cleaners, Silo Unloaders,	5 HP	23300	6000
Silo Hoists, Bunk Feeders)	7-1/2 HP	35000	8000
	10 HP	46700	10700
3-1/2 cu. ft. Mixer	1/2 HP	3300	1000
High Pressure 1.8 Gal/Min	500 PSI	3150	950
Washer 2 gal/min	550 PSI	4500	1400
2 gal/min	700 PSI	6100	1600
Refrigerator or Freezer		3100	800
Shallow Well Pump	1/3 HP	2150	750
	1/2 HP	3100	1000
Sump Pump	1/3 HP	2100	800
	1/2 HP	3200	1050

12-7. Approximate Power Requirements For Contractor Equipment

Contractor	Rating	Starting Watts	Running Watts
Hand Drill	1/4 in	350	350
	3/8 in	400	400
	1/2 in	600	600
Circular Saw	6-1/2 in	500	500
	7-1/4 in	900	900
	8-1/4 in	1400	1400
Table Saw	9 in	4500	1500
	10 in	6300	1800
Band Saw	14 in	2500	1100
Bench Grinder	6 in	1720	720
	8 in	3900	1400
	10 in	5200	1600
Air Compressor	1/2 HP	3000	1000
	1 HP	6000	1500
	1-1/2 HP	8200	2200
	2 HP	10500	2800
Electric Chain Saw	1-1/2 HP, 12 in	1100	1100
	2 HP, 14 in	1100	1100
Electric Trimmer	Standard 9 in	350	350
	Heavy Duty 12 in	500	500
Electric Cultivator	1/3 HP	2100	700
Elec. Hedge Trimmer	18 in	400	400
Flood Lights	HID	125	100
	Metal Halide	313	250
	Mercury	1000	
	Sodium Vapor	1400	1000
Submersible Pump	400 gph	600	200
Centrifugal Pump	900 gph	900	500
Floor Polisher	3/4 HP, 16 in	4500	1400
	1 HP, 20 in	6100	1600
High Pressure Washer	1/2 HP	3150	950
	3/4 HP	4500	1400
	1 HP	6100	1600
55 gal Drum Mixer	1/4 HP	1900	700
Wet & Dry Vac	1.7 HP	900	900
	2-1/2 HP	1300	1300

12-8. Power Required To Start Motor

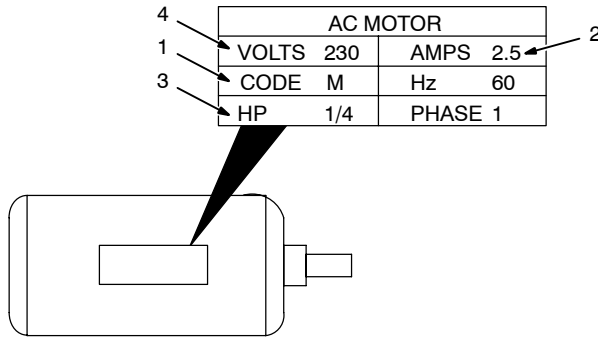

- 1 Motor Start Code
- 2 Running Amperage
- 3 Motor HP
- 4 Motor Voltage

To find starting amperage:

Step 1: Find code and use table to find kVA/HP. If code is not listed, multiply running amperage by six to find starting amperage.

Step 2: Find Motor HP and Volts.

Step 3: Determine starting amperage (see example).

Welding generator amperage output must be at least twice the motor's running amperage.

Single-Phase Induction Motor Starting Requirements

Motor Start Code	G	H	J	K	L	M	N	P
KVA/HP	6.3	7.1	8.0	9.0	10.0	11.2	12.5	14.0

$$\frac{\text{kVA/HP} \times \text{HP} \times 1000}{\text{VOLTS}} = \text{STARTING AMPERAGE}$$

EXAMPLE: Calculate the starting amperage required for a 230 V, 1/4 HP motor with a motor start code of M.

Volts = 230 HP = 1/4 Using Table, Code M results in kVA/HP = 11.2

$$\frac{11.2 \times 1/4 \times 1000}{230} = 12.2 \text{ A} \quad \text{Starting the motor requires 12.2 amperes.}$$

S-0624

12-9. How Much Power Can Generator Supply?

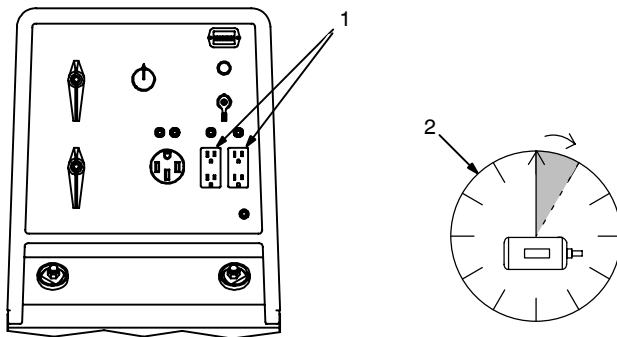

- 1 Limit Load To 90% Of Generator Output

Always start non-resistive (motor) loads in order from largest to smallest, and add resistive loads last.

- 2 5 Second Rule

If motor does not start within 5 seconds, turn off power to prevent motor damage. Motor requires more power than generator can supply.

Ref. ST-800 396-A / S-0625

12-10. Typical Connections To Supply Standby Power



▲ Properly install and ground this equipment according to its Owner's Manual and national, state, and local codes.

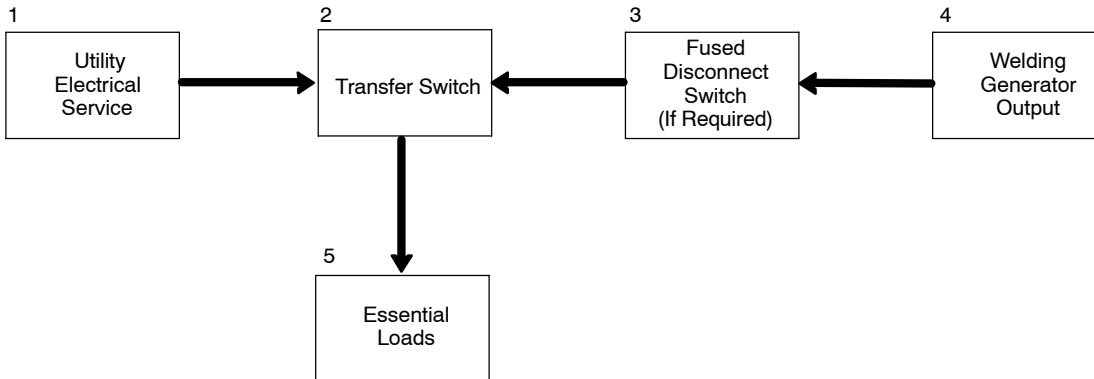

▲ Have only qualified persons perform these connections according to all applicable codes and safety practices.

▲ Properly install and ground this equipment according to its Owner's Manual and national, state, and local codes.

 Customer-supplied equipment is required if generator will supply standby power during emergencies or power outages.

1 Utility Electrical Service

2 Transfer Switch (Double-Throw)

Switch transfers the electrical load from electric utility service to the generator. Transfer load back to electric utility when service is restored.

Install correct switch (customer-supplied). Switch rating must be same as or greater than the branch overcurrent protection.

3 Fused Disconnect Switch

Install correct switch (customer-supplied) if required by electrical code.

4 Welding Generator Output

Generator output voltage and wiring must be consistent with regular (utility) system voltage and wiring.

Connect generator with temporary or permanent wiring suitable for the installation.

Turn off or unplug all equipment connected to generator before starting or stopping engine. When starting or stopping, the engine has low speed which causes low voltage and frequency.

5 Essential Loads

Generator output may not meet the electrical requirements of the premises. If generator does not produce enough output to meet all requirements, connect only essential loads (pumps, freezers, heaters, etc. – See Section 12-4).

Notes

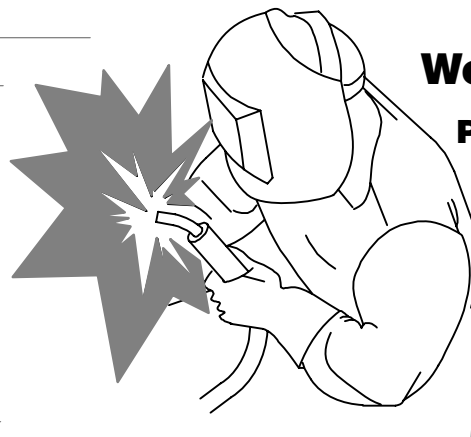

Work like a Pro!

Pros weld and cut safely. Read the safety rules at the beginning of this manual.

12-11. Selecting Extension Cord (Use Shortest Cord Possible)



Cord Lengths for 120 Volt Loads

▲ If unit does not have GFCI receptacles, use GFCI-protected extension cord.

Current (Amperes)	Load (Watts)	Maximum Allowable Cord Length in ft (m) for Conductor Size (AWG)*					
		4	6	8	10	12	14
5	600			350 (106)	225 (68)	137 (42)	100 (30)
7	840		400 (122)	250 (76)	150 (46)	100 (30)	62 (19)
10	1200	400 (122)	275 (84)	175 (53)	112 (34)	62 (19)	50 (15)
15	1800	300 (91)	175 (53)	112 (34)	75 (23)	37 (11)	30 (9)
20	2400	225 (68)	137 (42)	87 (26)	50 (15)	30 (9)	
25	3000	175 (53)	112 (34)	62 (19)	37 (11)		
30	3600	150 (46)	87 (26)	50 (15)	37 (11)		
35	4200	125 (38)	75 (23)	50 (15)			
40	4800	112 (34)	62 (19)	37 (11)			
45	5400	100 (30)	62 (19)				
50	6000	87 (26)	50 (15)				

*Conductor size is based on maximum 2% voltage drop

Cord Lengths for 240 Volt Loads

▲ If unit does not have GFCI receptacles, use GFCI-protected extension cord.

Current (Amperes)	Load (Watts)	Maximum Allowable Cord Length in ft (m) for Conductor Size (AWG)*					
		4	6	8	10	12	14
5	1200			700 (213)	450 (137)	225 (84)	200 (61)
7	1680		800 (244)	500 (152)	300 (91)	200 (61)	125 (38)
10	2400	800 (244)	550 (168)	350 (107)	225 (69)	125 (38)	100 (31)
15	3600	600 (183)	350 (107)	225 (69)	150 (46)	75 (23)	60 (18)
20	4800	450 (137)	275 (84)	175 (53)	100 (31)	60 (18)	
25	6000	350 (107)	225 (69)	125 (38)	75 (23)		
30	7000	300 (91)	175 (53)	100 (31)	75 (23)		
35	8400	250 (76)	150 (46)	100 (31)			
40	9600	225 (69)	125 (38)	75 (23)			
45	10,800	200 (61)	125 (38)				
50	12,000	175 (53)	100 (31)				

*Conductor size is based on maximum 2% voltage drop

SECTION 13 – STICK WELDING (SMAW) GUIDELINES



13-1. Stick Welding Procedure

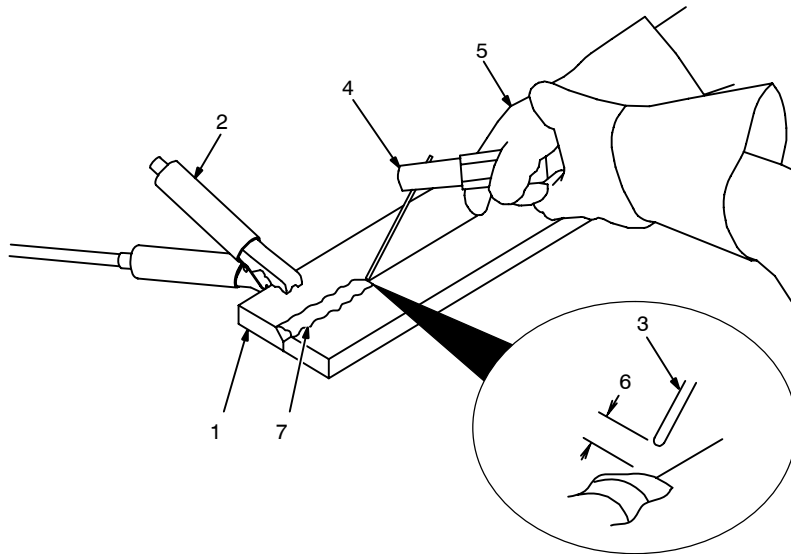

▲ Weld current starts when electrode touches workpiece.

▲ Weld current can damage electronic parts in vehicles. Disconnect both battery cables before welding on a vehicle. Place work clamp as close to the weld as possible.

1 Workpiece

Make sure workpiece is clean before welding.

2 Work Clamp

3 Electrode

A small diameter electrode requires less current than a large one. Follow electrode manufacturer's instructions when setting weld amperage (see Section 13-2).

4 Insulated Electrode Holder

5 Electrode Holder Position

6 Arc Length

Arc length is the distance from the electrode to the workpiece. A short arc with correct amperage will give a sharp, crackling sound.

7 Slag

Use a chipping hammer and wire brush to remove slag. Remove slag and check weld bead before making another weld pass.

Tools Needed:

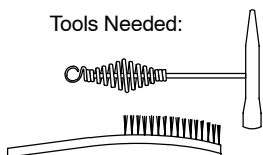

13-2. Electrode and Amperage Selection Chart

ELECTRODE	DIAMETER	AMPERAGE RANGE								
		50	100	150	200	250	300	350	400	450
6010 & 6011	3/32									
	1/8									
	5/32									
	3/16									
	7/32									
6013	1/4									
	1/16									
	5/64									
	3/32									
	1/8									
	5/32									
	3/16									
7014	7/32									
	1/4									
	3/32									
	1/8									
	5/32									
7018	3/16									
	7/32									
	1/4									
	3/32									
	1/8									
7024	5/32									
	3/16									
	7/32									
	1/4									
	3/32									
Ni-CI	1/8									
	5/32									
	3/16									
308L	3/32									
	1/8									
	5/32									

ELECTRODE	DC*	AC	POSITION	PENETRATION	USAGE
6010	EP		ALL	DEEP	MIN. PREP, ROUGH
6011	EP	✓	ALL	DEEP	HIGH SPATTER
6013	EP,EN	✓	ALL	LOW	GENERAL
7014	EP,EN	✓	ALL	MED	SMOOTH, EASY, FAST
7018	EP	✓	ALL	LOW	LOW HYDROGEN, STRONG
7024	EP,EN	✓	FLAT HORIZ FILLET	LOW	SMOOTH, EASY, FASTER
NI-CL	EP	✓	ALL	LOW	CAST IRON
308L	EP	✓	ALL	LOW	STAINLESS

*EP = ELECTRODE POSITIVE (REVERSE POLARITY)
EN = ELECTRODE NEGATIVE (STRAIGHT POLARITY)

Ref. S-087 985-A

13-3. Striking an Arc – Scratch Start Technique

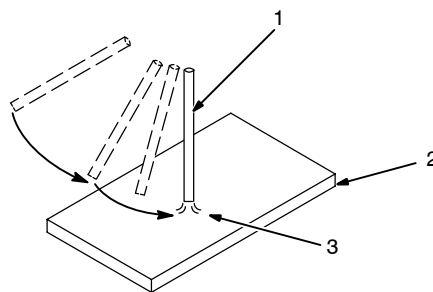

- 1 Electrode
- 2 Workpiece
- 3 Arc

Drag electrode across workpiece like striking a match; lift electrode slightly after touching work. If arc goes out electrode was lifted too high. If electrode sticks to workpiece, use a quick twist to free it.

S-0049

13-4. Striking an Arc – Tapping Technique

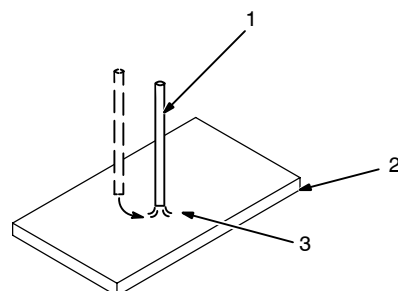

- 1 Electrode
- 2 Workpiece
- 3 Arc

Bring electrode straight down to workpiece; then lift slightly to start arc. If arc goes out, electrode was lifted too high. If electrode sticks to workpiece, use a quick twist to free it.

S-0050

13-5. Positioning Electrode Holder

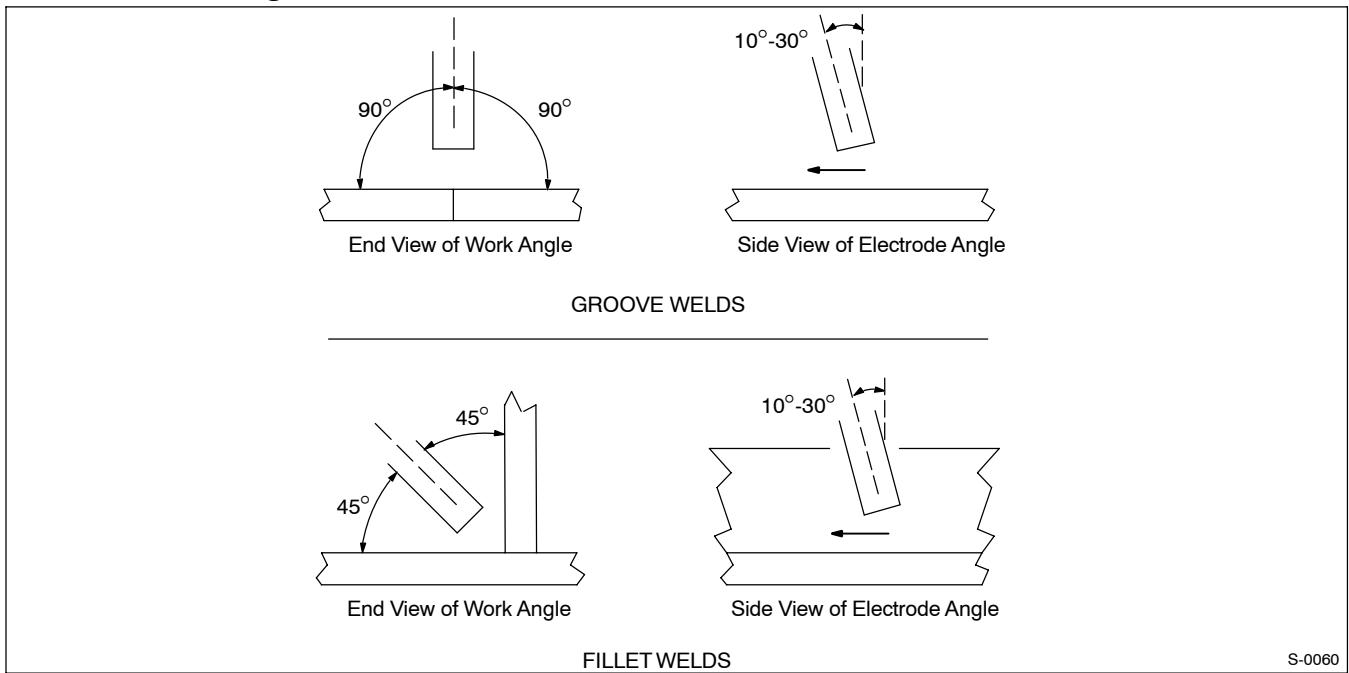

S-0060

13-6. Poor Weld Bead Characteristics

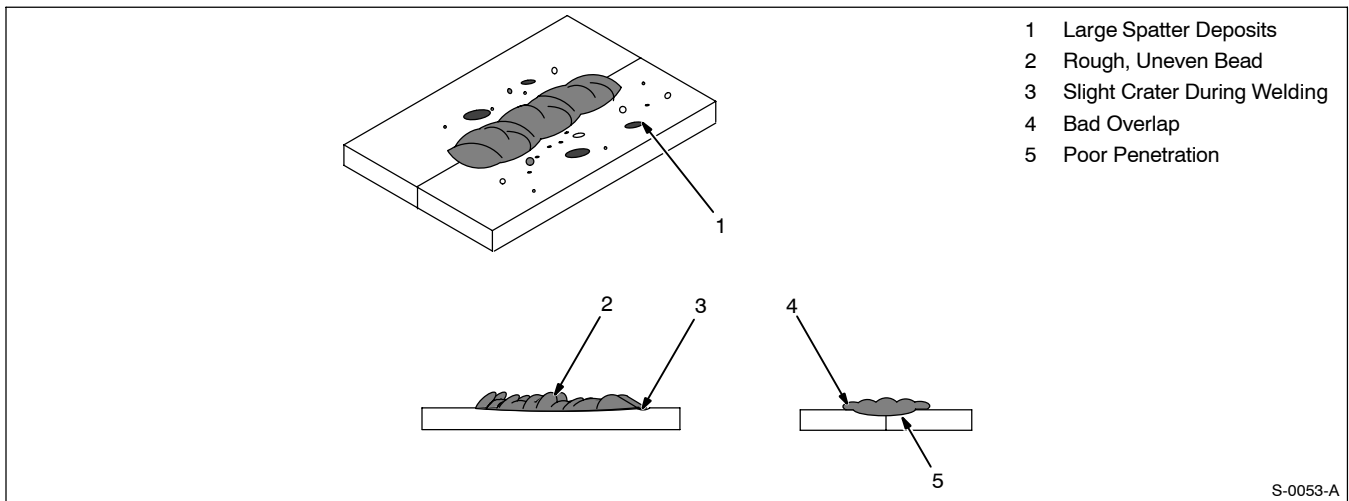

S-0053-A

13-7. Good Weld Bead Characteristics

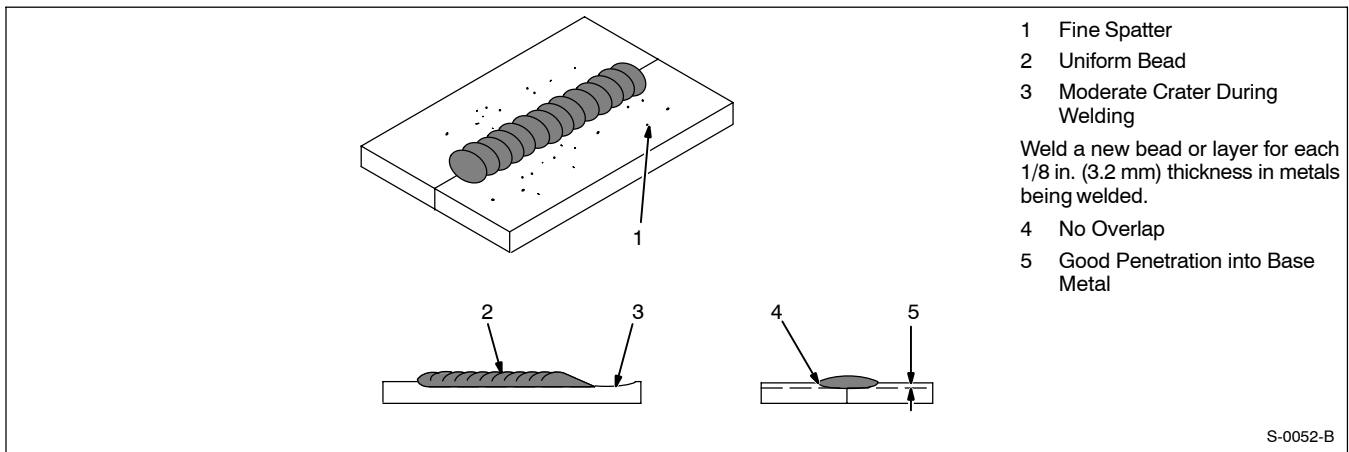

S-0052-B

13-8. Conditions That Affect Weld Bead Shape

NOTE 

Weld bead shape is affected by electrode angle, arc length, travel speed, and thickness of base metal.

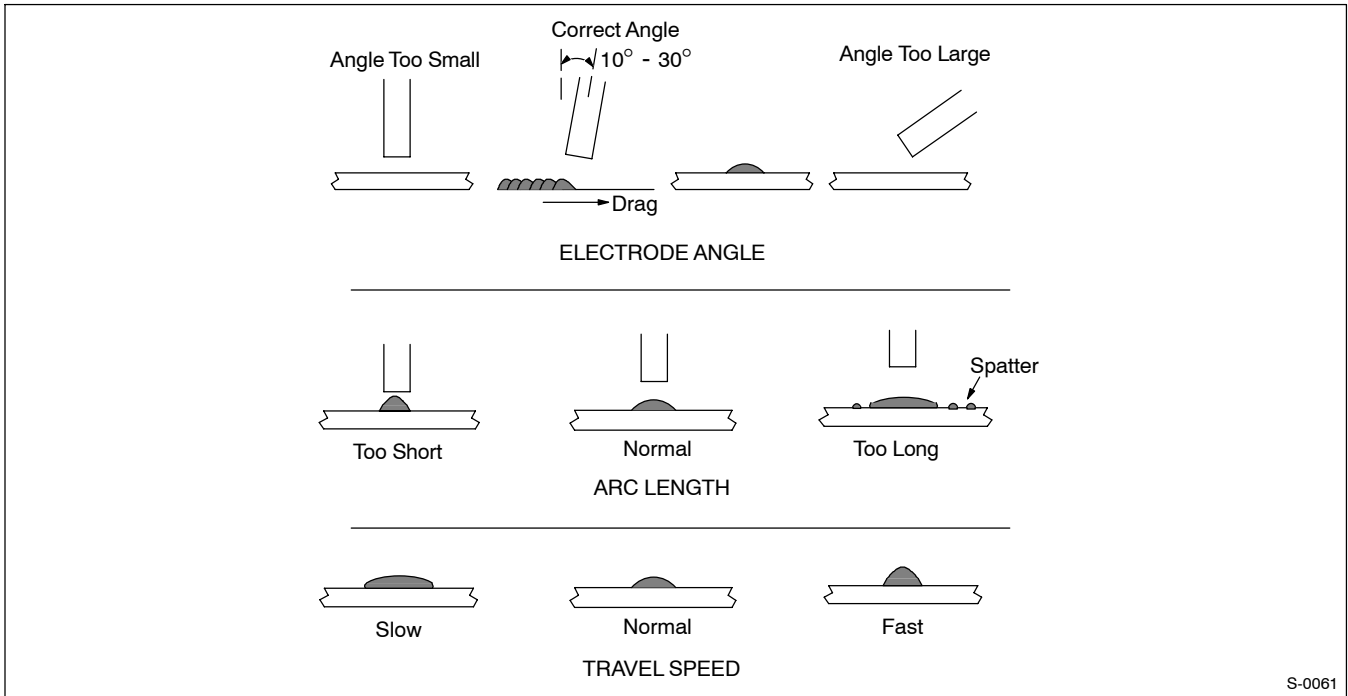

13-9. Electrode Movement During Welding

NOTE 

Normally, a single stringer bead is satisfactory for most narrow groove weld joints; however, for wide groove weld joints or bridging across gaps, a weave bead or multiple stringer beads work better.

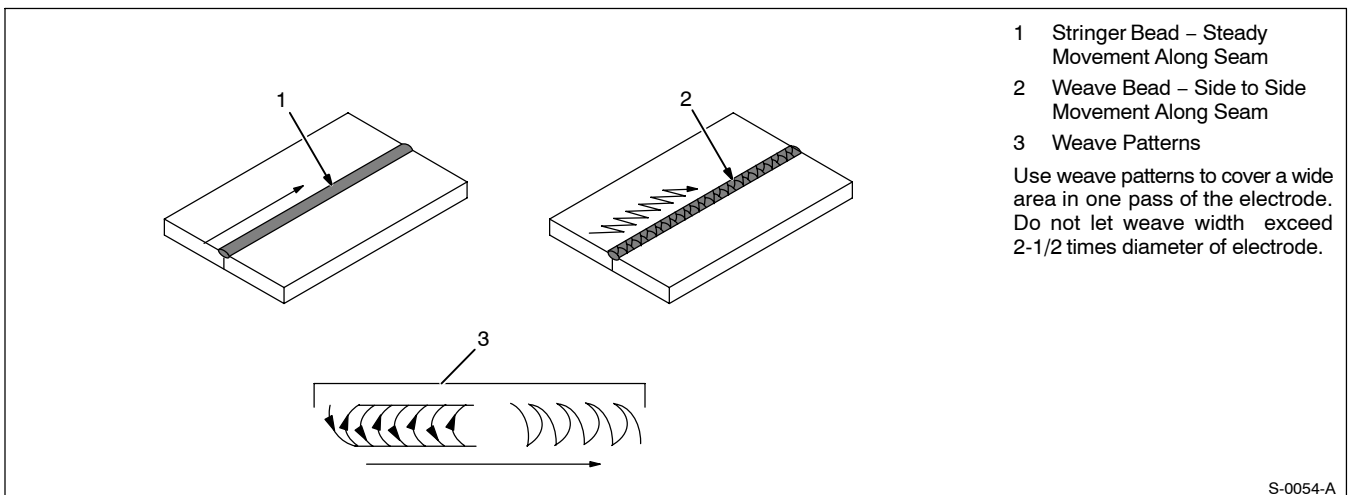

13-10. Butt Joints

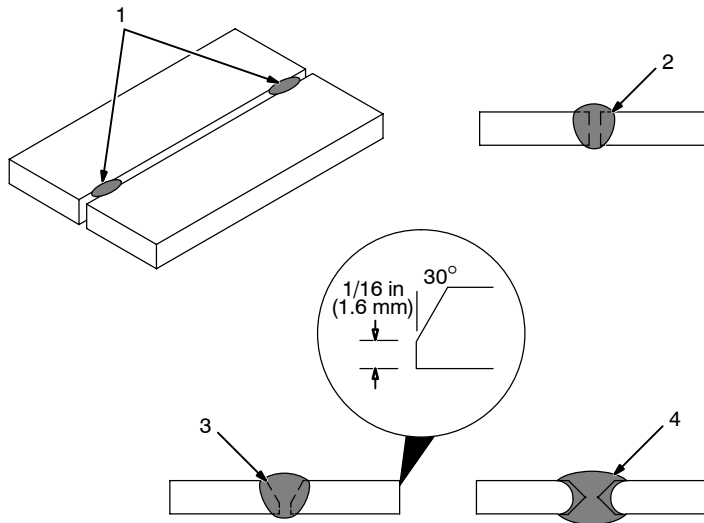

1 Tack Welds

Prevent edges of joint from drawing together ahead of electrode by tack welding the materials in position before final weld.

2 Square Groove Weld

Good for materials up to 3/16 in (5 mm) thick.

3 Single V-Groove Weld

Good for materials 3/16 – 3/4 in (5-19 mm) thick. Cut bevel with oxy-acetylene or plasma cutting equipment. Remove scale from material after cutting. A grinder can also be used to prepare bevels.

Create 30 degree angle of bevel on materials in V-groove welding.

4 Double V-Groove Weld

Good for materials thicker than 3/16 in (5 mm).

S-0662

13-11. Lap Joint

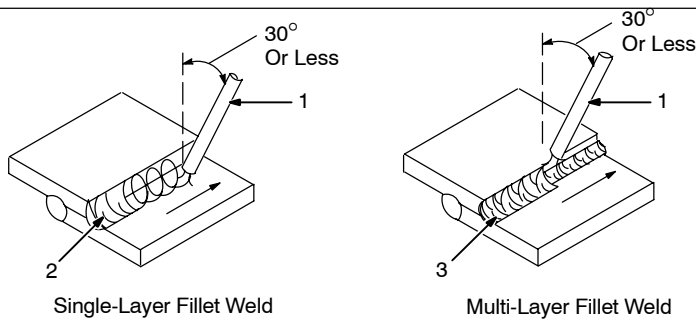

Single-Layer Fillet Weld

Multi-Layer Fillet Weld

1 Electrode

2 Single-Layer Fillet Weld

Move electrode in circular motion.

3 Multi-Layer Fillet Weld

Weld a second layer when a heavier fillet is needed. Remove slag before making another weld pass. Weld both sides of joint for maximum strength.

S-0063 / S-0064

13-12. Tee Joint

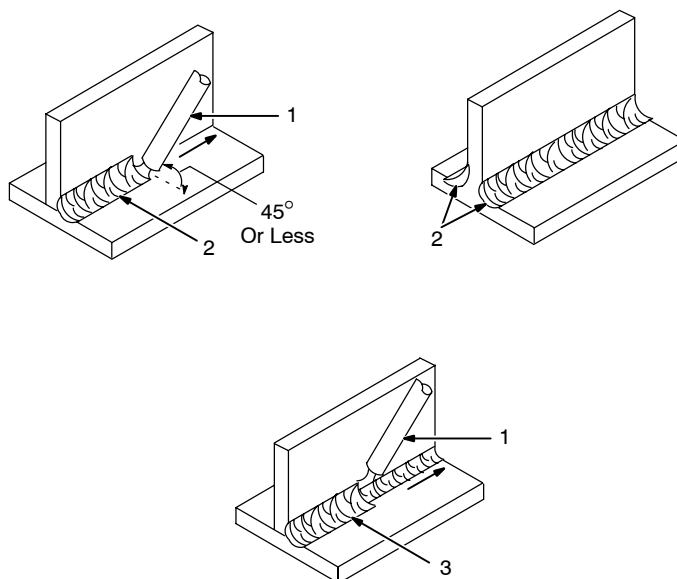

1 Electrode

2 Fillet Weld

Keep arc short and move at definite rate of speed. Hold electrode as shown to provide fusion into the corner. Square edge of the weld surface.

For maximum strength weld both sides of upright section.

3 Multi-Layer Deposits

Weld a second layer when a heavier fillet is needed. Use any of the weaving patterns shown in Section 13-9. Remove slag before making another weld pass.

S-0060 / S-0058-A / S-0061

13-13. Weld Test

1 Vise
2 Weld Joint
3 Hammer

Strike weld joint in direction shown. A good weld bends over but does not break.

S-0057-B

13-14. Troubleshooting – Porosity

Porosity – small cavities or holes resulting from gas pockets in weld metal.

Possible Causes	Corrective Actions
Arc length too long.	Reduce arc length.
Damp electrode.	Use dry electrode.
Workpiece dirty.	Remove all grease, oil, moisture, rust, paint, coatings, slag, and dirt from work surface before welding.

13-15. Troubleshooting – Excessive Spatter

Excessive Spatter – scattering of molten metal particles that cool to solid form near weld bead.

Possible Causes	Corrective Actions
Amperage too high for electrode.	Decrease amperage or select larger electrode.
Arc length too long or voltage too high.	Reduce arc length or voltage.

13-16. Troubleshooting – Incomplete Fusion

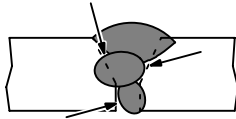
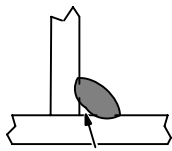

Incomplete Fusion – failure of weld metal to fuse completely with base metal or a preceding weld bead.

Possible Causes	Corrective Actions
Insufficient heat input.	Increase amperage. Select larger electrode and increase amperage.
Improper welding technique.	Place stringer bead in proper location(s) at joint during welding.
	Adjust work angle or widen groove to access bottom during welding.
	Momentarily hold arc on groove side walls when using weaving technique.
	Keep arc on leading edge of weld puddle.
Workpiece dirty.	Remove all grease, oil, moisture, rust, paint, coatings, slag, and dirt from work surface before welding.

13-17. Troubleshooting – Lack Of Penetration

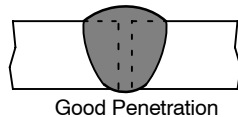
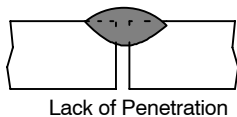

Lack Of Penetration – shallow fusion between weld metal and base metal.

Possible Causes	Corrective Actions
Improper joint preparation.	Material too thick. Joint preparation and design must provide access to bottom of groove.
Improper weld technique.	Keep arc on leading edge of weld puddle.
Insufficient heat input.	Increase amperage. Select larger electrode and increase amperage.
	Reduce travel speed.

13-18. Troubleshooting – Excessive Penetration

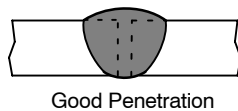
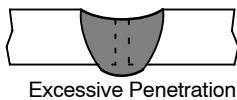

Excessive Penetration – weld metal melting through base metal and hanging underneath weld.

Possible Causes	Corrective Actions
Excessive heat input.	Select lower amperage. Use smaller electrode.
	Increase and/or maintain steady travel speed.

13-19. Troubleshooting – Burn-Through

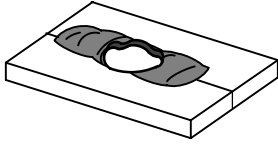

Burn-Through – weld metal melting completely through base metal resulting in holes where no metal remains.

Possible Causes	Corrective Actions
Excessive heat input.	Select lower amperage. Use smaller electrode.
	Increase and/or maintain steady travel speed.

13-20. Troubleshooting – Waviness Of Bead

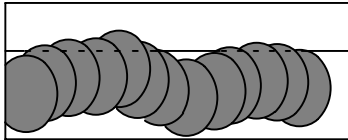

Waviness Of Bead – weld metal that is not parallel and does not cover joint formed by base metal.

Possible Causes	Corrective Actions
Unsteady hand.	Use two hands. Practice technique.

13-21. Troubleshooting – Distortion

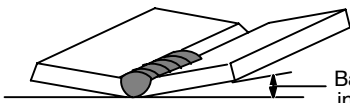

Base metal moves in the direction of the weld bead.

Distortion – contraction of weld metal during welding that forces base metal to move.

Possible Causes	Corrective Actions
Excessive heat input.	Use restraint (clamp) to hold base metal in position.
	Make tack welds along joint before starting welding operation.
	Select lower amperage for electrode.
	Increase travel speed.
	Weld in small segments and allow cooling between welds.

SECTION 14 – PARTS LIST

 Hardware is common and not available unless listed.

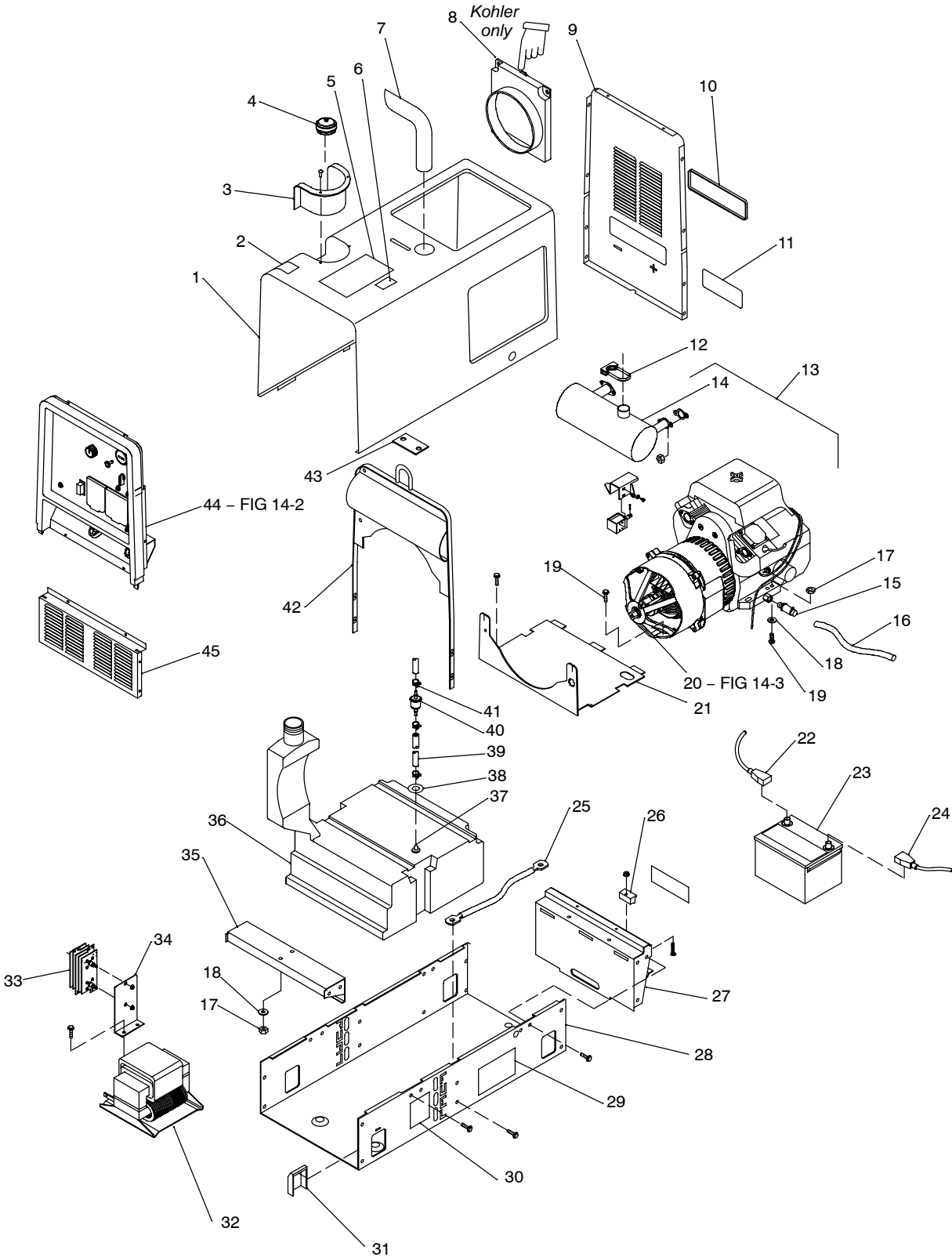

Figure 14-1. Main Assembly (Robin Engine Shown)

Item No.	Dia. Mkgs.	Part No.	Description	Quantity
Figure 14-1. Main Assembly				
1		+193 777	Wrapper	1
2		227 725	Label, Use Gasoline Fuel Only	1
3		211 398	Grommet, Plastic Neck Filler Fuel	1
4		220 711	Cap, Tank Screw-on w/Vent	1
5		227 726	Label, Warning General Precautionary CSA	1
6		220 457	Label, Need Help	1
7		211 527	Pipe, Exhaust Elbow	1
8		196 252	Baffle, engine air (Kohler only)	1
9		226 448	Panel, Rear	1
10		194 263	Grommet, Plastic Snap-in Battery Access	1
11		227 913	Label, Warning Battery Explosion Can Blind	1
12		209 057	Clamp, Muffler 1.625 Dia U Pld	1
13		224 134	Engine, Robin Gas Elec Start (consisting of)	1
14		228 679	Muffler, Exhaust Engine (Robin)	1
		217 441	Gasket, muffler	2
		*198 754	Filter, oil	1
		*198 755	Element, air cleaner w/precleaner	1
		198 756	Pump, fuel	1
	S5	198 757	Switch, low oil pressure	1
		*215 985	Filter, fuel w/clamps	1
		*198 777	Plug, spark	2
			Solenoid w/ mtg bracket (see engine parts list)	1
		198 778	Regulator, voltage	1
15		165 271	Valve, Oil Drain 3/8-18 Nptf	1
	F6	*021 718	Fuse, Mintr GI 30. Amp 32 Volt	1
		114 923	Boot, solenoid	1
		199 062	Kit, tune-up and filter - Robin (includes air filter element and wrapper, oil filter, fuel filter, and spark plugs)	1
13		230 512	Engine, Kohler Gas Elec Ch20s-ps-64760 (consisting of)	1
14		228 678	Muffler, Exhaust Engine (Kohler)	1
		189 477	Gasket, muffler	2
		230 506	Harness, Adapter	1
		066 698	Filter, oil	1
		190 248	Pump, fuel	1
		067 272	Element, air cleaner	1
		*215 985	Filter, fuel w/clamps	1
		*067 273	Wrapper, air filter	1
		067 007	Plug, spark	2
		199 530	Solenoid, idle	1
15		165 271	Valve, Oil Drain 3/8-18 Nptf	1
	F6	*021 718	Fuse, Mintr GI 30. Amp 32 Volt	1
		114 923	Boot, solenoid	1
		180 096	Kit, tune-up and filter - Kohler (includes air filter element and wrapper, oil filter, fuel filter, and spark plugs)	1
16		196 778	Hose, Vinyl Clear .500 Id X .625 Od X 7.000 (oil drain)	1
17		167 788	Nut, 375-16 .56hex .34h Stl Pld Sem Cone Wshr.88d	3
18		151 542	Washer, Flat .438idx1.000odx.125t Stl Pld	3
19		142 156	Screw, 375-16x1.75 Hexwhd.81d Gr8 Pld	3
20		Figure 14-3	Generator	1
21		193 782	Cover, Tank Fuel	1
22		217 848	Cable, Bat Neg 15.000 No 4 Awg W/Clamp & .343 Rng	1
23		168 037	Battery, Stor 12v 430 Crk 75 Rsv Gp 58 Dry	1
24		219 811	Cable, Bat Pos 25.000 No 4 Awg W/Clamp & .312 Rng	1
25		172 669	Cable, Bat Neg 11.000 6ga W/.250 Rng & .375 Rng	1
26		182 935	Hold Down, Battery	1
27		193 780	Bracket, Mtg Engine	1
28		+226 446	Base	1
29		215 939	Label, Engine Maintenance	1
30		229 134	Label, warning do not weld on base	2

Item No.	Dia. Mkgs.	Part No.	Description	Quantity
----------	------------	----------	-------------	----------

Figure 14-1. Main Assembly (Continued)

.. 31		181 057	.. Cover, Base	2
.. 32	DC-Z	205 978	.. Stabilizer Assy,	1
.. 33	SR1	192 682	.. Rectifier, Si 1ph 240 Amp 400 Piv 60% Duty Cycle	1
.. 34		208 149	.. Bracket, Mtg. Rectifier	1
.. 35		193 781	.. Bracket, Mtg Generator	1
.. 36		193 627	.. Tank, Fuel 10 Gal (consisting of)	1
.. 37		178 632	.. Ftg, Stand Pipe .250 X 7.375 Lg	1
.. 38		124 253	.. Bushing, Tank Fuel	1
.. 39		145 976	.. Hose, Sae .250 Id X .500 Od X 4.500	1
.. 40		066 113	.. Filter, Fuel Inline .250 (included w/engine)	1
.. 41		084 173	.. Clamp, Hose .460 - .545 Clp Dia Slftng	3
.. 42		193 810	.. Upright, Base	1
.. 43		160 975	.. Seal, Weather Lift Eye	1
.. 44		Figure 14-2	.. Panel, Front w/Components	1
.. 45		180 628	.. Panel, Front Lower	1
		193 067	.. Kit, Accy 20 Ft (#2) W/Elec Hldr 15 Ft Grd (consisting of)	1
		600 319	.. Cable, Weld Cop Strd No 2 Epdm Jkt (order by ft)	35ft
		040 234	.. Af-2 Holder, Electrode 200a	1
		130 750	.. Clamp, Work 300 Amp	1
		600 720	.. Term, Ring Tng 500stud Solistrand 2ga	2
		034 377	.. Term, Ring Tng 312stud Solistrand 2ga	1

+When ordering a component originally displaying a precautionary label, the label should also be ordered.

* Recommended Spare Parts.

To maintain the factory original performance of your equipment, use only Manufacturer's Suggested Replacement Parts. Model and serial number required when ordering parts from your local distributor.

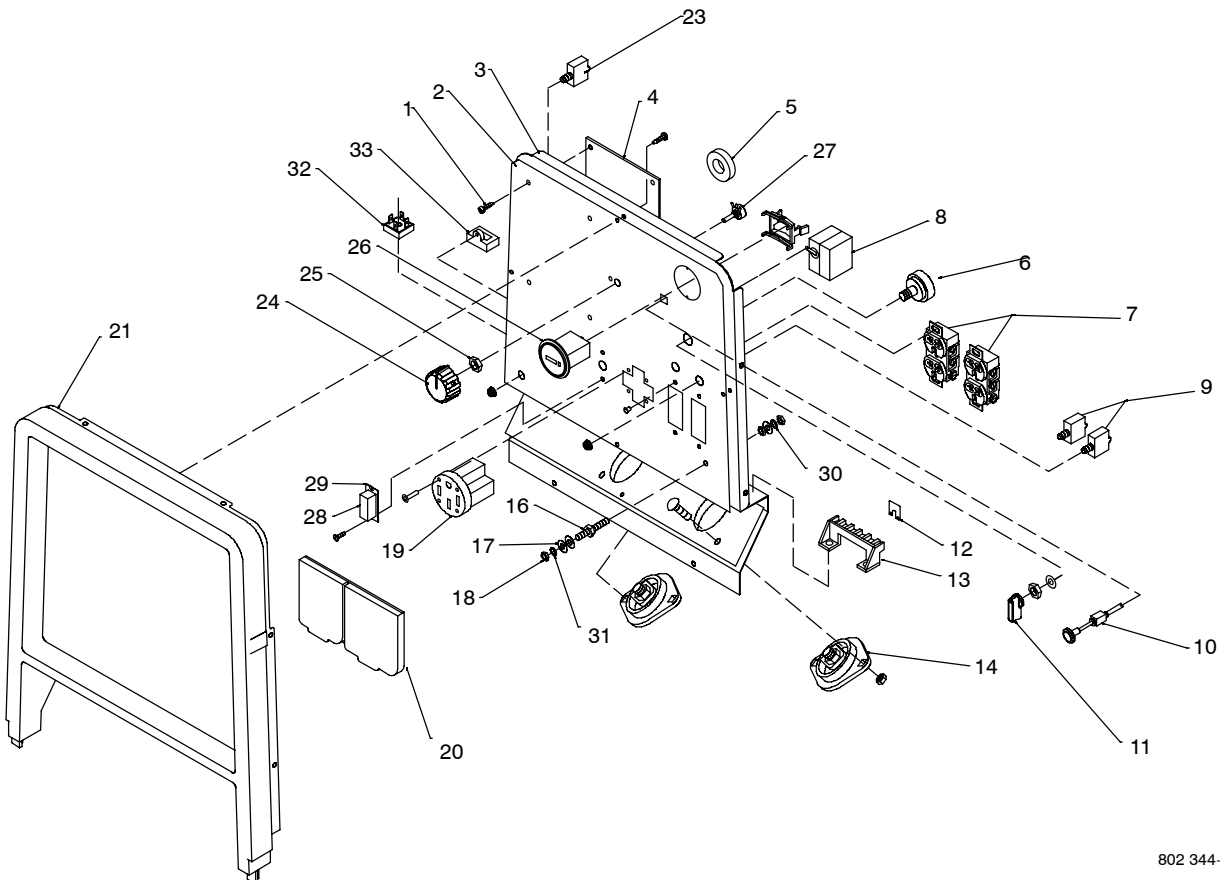

802 344-K

Figure 14-2. Panel, Front w/Components

Item No.	Dia. Mkgs.	Part No.	Description	Quantity
Figure 14-2. Panel, Front w/Components (Figure 14-1 Item 47)				
1		198 122	Stand-off Support, Pc Card .250w/Post&lock .500	6
2			Nameplate (order by model & serial no.)	1
3		226 447	Panel, Front	1
4	PC1	203 655	Circuit Card Assy, Field Current Controller	1
5	CT1	204 709	Xfmr, Current Sensing	1
6	S2	217 680	Switch, Ignition 4 Position Without Handle	1
		222 133	Harness, Wrg Ignition (consisting of)	1
	PLG8	177 859	Conn, Body 5 Terminal	1
	PLG4	116 045	Conn, Rect Univ 084 6p/S 3row Rcpt (Housing, Pins & Skts Service Kit)	1
	PLG5	066 104	Conn, Rect Univ 084 9p/S 3row Rcpt (Housing, Pins & Skts Service Kit)	1
	PLG9	130 204	Conn, Rect Univ 084 3p/S 1row Plug Cable Lkg (Housing, Pins & Skts Service Kit)	1
7	RC2, RC3	141 432	Rcpt, Str Dx Grd 2p3w 20a 125v *5-20r	2
7	GFCI2, GFCI3	◆151 981	Rcpt, Str Dx Grd 2p3w 15/20a 125v *5-20r GFI	2
8	CB1	218 591	Supplementary Protector, Man Reset 2p 50a 240vac	1
9	CB2, CB3	093 996	Supplementary Pro, Man Reset 1p 20a 250vac Frict	2
10		203 993	Control, Push/Pull Snap-in 36.000 W/1.750 Extension	1
11		207 073	Lever, Ignition Switch	1
12		173 734	Link, Jumper	1
13	1T	172 661	Block, Stud Connection 6 Position	1
14		099 255	Terminal, Pwr Output Neutral	2
15		Deleted		
16		083 030	Stud, brs .250-20 x 1.750	1
17		010 915	Washer, flat brs	3
18		601 836	Nut, .250-20 brs	3
19	RC1	182 954	Rcpt, Str 3p4w 50a 125/250v Flush Mtg *14-50	1
20		188 039	Cover, Receptacle W/Gasket	1
21		159 921	Bezel	1
22		Deleted		
23	CB4	161 078	Circuit Breaker, Man Reset 1p 7a 250vac Fri	1
24		207 077	Knob, Pointer 1.625 Dia Push-On	1
25		072 590	Lock, Shaft Pot .375-32 X .250 Dia Shaft Tall	1
26	HM	223 164	Meter, Hour 12-60vdc 2.00 Dia	1
27	R1	201 486	Potentiometer, w/leads	1
28		202 631	Cover, Circuit Breaker	1
29		202 630	Brkt,Mtg Ckt Breaker Cover	1
30		602 207	Washer, Lock .255idx0.489odx.062t Stl Pld Split.250	1
31		163 167	Washer, Lock .254idx0.489odx.062t Sst Split.250	1
32	SR2	035 704	Rectifier, Integ Bridge 40 Amp 800 V	1
33	LEM	191 941	Transducer, Current	1
		220 632	Harness, Wrg, Feedback (consisting of)	1
		220 629	Cable, Lem	1
		135 134	Conn,Rect Univ 084 9p/S 3row Plug Cable Lkg	1

◆Optional

To maintain the factory original performance of your equipment, use only Manufacturer's Suggested Replacement Parts. Model and serial number required when ordering parts from your local distributor.

Item No.	Part No.	Description	Quantity
----------	----------	-------------	----------

Figure 14-3. Generator (Figure 14-1 Item 20)

.. 1	+220 832 ..	Generator Assy, Front (consisting of)	1
.. 2	183 419	O-ring, 1.984 Id X .139 Cs 70 Duro Viton	1
.. 3	227 724 ..	Label, Warning Moving Parts Can Cause Serious Etc	1
.. 4	185 148 ..	Housing, Generator Rear	1
.. 5	186 083 ..	Screw, 437-14x1.75 Hexwhd.93d Gr8 Pld	4
.. 6	222 130 ..	Rotor, Generator (consisting of)	1
.. 7	181 134	Fan, Rotor Gen	1
.. 8	181 143	Bearing, Ball Rdl Sgl Row .984 X 2.047 X .59	1
.. 9	205 725 ..	Brushholder Assy, Generator	1
.. 10	142 156 ..	Screw, 375-16x1.75 Hexwhd.81d Gr8 Pld	4

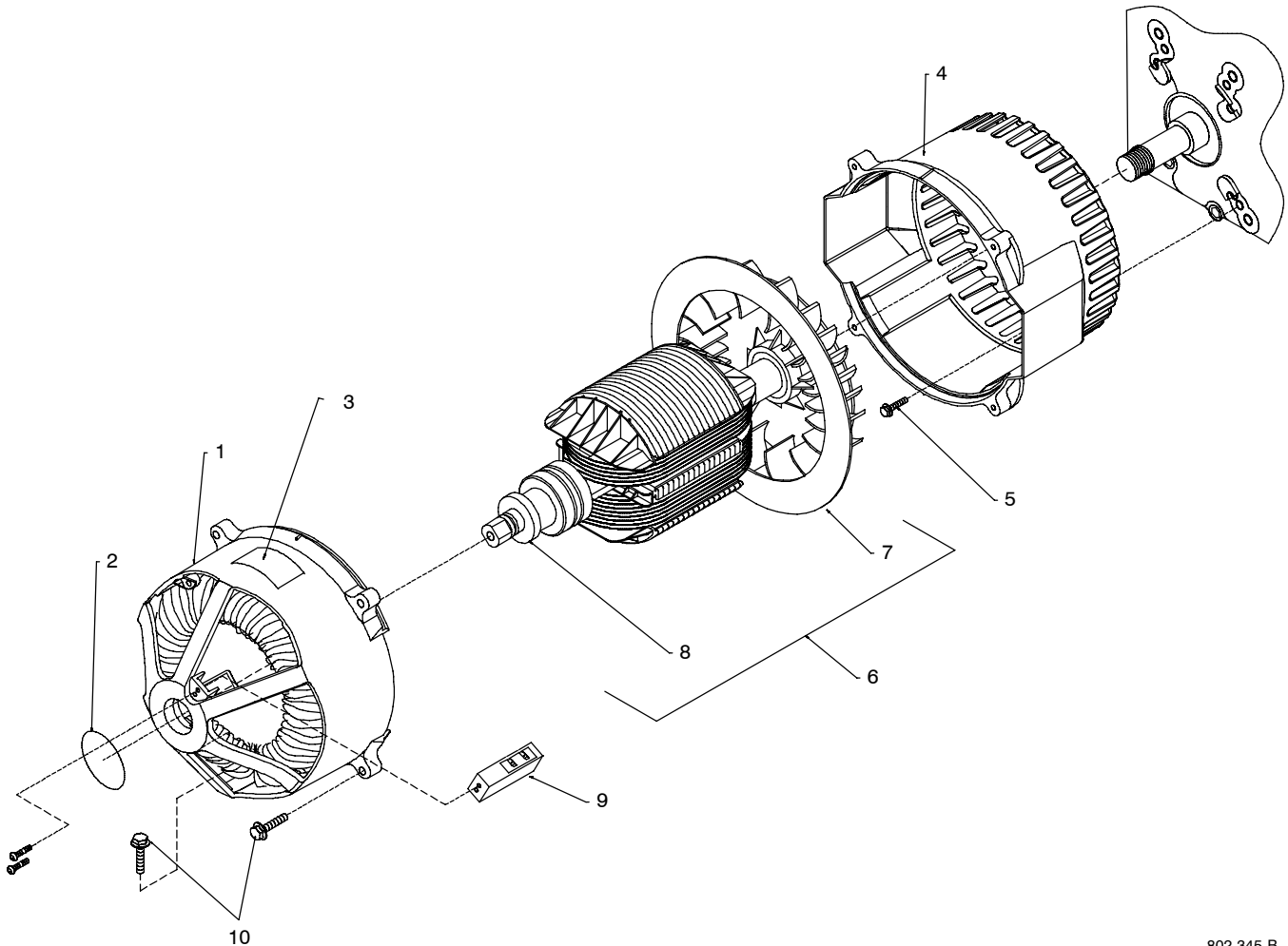

802 345-B

Figure 14-3. Generator

+When ordering a component originally displaying a precautionary label, the label should also be ordered.
To maintain the factory original performance of your equipment, use only Manufacturer's Suggested Replacement Parts. Model and serial number required when ordering parts from your local distributor.

HOBART 5/3/1 WARRANTY

Effective January 1, 2006

5/3/1 WARRANTY applies to all Hobart welding equipment, plasma cutters and spot welders with a serial number preface LG or newer.

This limited warranty supersedes all previous Hobart warranties and is exclusive with no other guarantees or warranties expressed or implied.

Hobart products are serviced by Hobart or Miller Authorized Service Agencies.

LIMITED WARRANTY – Subject to the terms and conditions below, Hobart/Miller Electric Mfg. Co., Appleton, Wisconsin, warrants to its original retail purchaser that new Hobart equipment sold after the effective date of this limited warranty is free of defects in material and workmanship at the time it is shipped by Hobart. THIS WARRANTY IS EXPRESSLY IN LIEU OF ALL OTHER WARRANTIES, EXPRESS OR IMPLIED, INCLUDING THE WARRANTIES OF MERCHANTABILITY AND FITNESS.

Within the warranty periods listed below, Hobart/Miller will repair or replace any warranted parts or components that fail due to such defects in material or workmanship. Hobart/Miller must be notified in writing within thirty (30) days of such defect or failure, at which time Hobart/Miller will provide instructions on the warranty claim procedures to be followed.

Hobart/Miller shall honor warranty claims on warranted equipment listed below in the event of such a failure within the warranty time periods. All warranty time periods start on the date that the equipment was delivered to the original retail purchaser, or one year after the equipment is sent to a North American distributor or eighteen months after the equipment is sent to an International distributor.

1. 5 Years — Parts and Labor
 - * Original Main Power Rectifiers
 - * Transformers
 - * Stabilizers
 - * Reactors
2. 3 Years — Parts and Labor
 - * Drive Systems
 - * PC Boards
 - * Rotors, Stators and Brushes
 - * Idle Module
 - * Solenoid Valves
 - * Switches and Controls
 - * Spot Welder Transformer
3. 1 Year — Parts and Labor Unless Specified (90 days for industrial use)
 - * Motor-Driven Guns
 - * MIG Guns/TIG Torches
 - * Relays
 - * Contactors
 - * Regulators
 - * Water Coolant Systems
 - * Flowgauge and Flowmeter Regulators (No Labor)
 - * HF Units
 - * Running Gear/Trailers
 - * Plasma Cutting Torches
 - * Remote Controls
 - * Replacement Parts (No labor) – 90 days
 - * Accessories
 - * Field Options
(NOTE: Field options are covered for the remaining warranty period of the product they are installed in, or for a minimum of one year — whichever is greater.)
4. Engines, batteries and tires are warranted separately by the manufacturer.

Hobart's 5/3/1 Limited Warranty shall not apply to:

1. **Consumable components such as contact tips, cutting nozzles, slip rings, drive rolls, gas diffusers, plasma torch tips and electrodes, weld cables, and tongs and tips, or parts that fail due to normal wear.** (Exception: brushes, slip rings, and relays are covered on Hobart Engine-Driven models.)
2. Items furnished by Hobart/Miller, but manufactured by others, such as engines or trade accessories. These items are covered by the manufacturer's warranty, if any.
3. Equipment that has been modified by any party other than Hobart/Miller, or equipment that has been improperly installed, improperly operated or misused based upon industry standards, or equipment which has not had reasonable and necessary maintenance, or equipment which has been used for operation outside of the specifications for the equipment.

HOBART PRODUCTS ARE INTENDED FOR PURCHASE AND USE BY COMMERCIAL/INDUSTRIAL USERS AND PERSONS TRAINED AND EXPERIENCED IN THE USE AND MAINTENANCE OF WELDING EQUIPMENT.

In the event of a warranty claim covered by this warranty, the exclusive remedies shall be, at Hobart's/Miller's option: (1) repair; or (2) replacement; or, where authorized in writing by Hobart/Miller in appropriate cases, (3) the reasonable cost of repair or replacement at an authorized Hobart/Miller service station; or (4) payment of or credit for the purchase price (less reasonable depreciation based upon actual use) upon return of the goods at customer's risk and expense. Hobart's/Miller's option of repair or replacement will be F.O.B., Factory at Appleton, Wisconsin, or F.O.B. at a Hobart/Miller authorized service facility as determined by Hobart/Miller. Therefore no compensation or reimbursement for transportation costs of any kind will be allowed.

TO THE EXTENT PERMITTED BY LAW, THE REMEDIES PROVIDED HEREIN ARE THE SOLE AND EXCLUSIVE REMEDIES. IN NO EVENT SHALL HOBART/MILLER BE LIABLE FOR DIRECT, INDIRECT, SPECIAL, INCIDENTAL OR CONSEQUENTIAL DAMAGES (INCLUDING LOSS OF PROFIT), WHETHER BASED ON CONTRACT, TORT OR ANY OTHER LEGAL THEORY.

ANY EXPRESS WARRANTY NOT PROVIDED HEREIN AND ANY IMPLIED WARRANTY, GUARANTY OR REPRESENTATION AS TO PERFORMANCE, AND ANY REMEDY FOR BREACH OF CONTRACT TORT OR ANY OTHER LEGAL THEORY WHICH, BUT FOR THIS PROVISION, MIGHT ARISE BY IMPLICATION, OPERATION OF LAW, CUSTOM OF TRADE OR COURSE OF DEALING, INCLUDING ANY IMPLIED WARRANTY OF MERCHANTABILITY OR FITNESS FOR PARTICULAR PURPOSE, WITH RESPECT TO ANY AND ALL EQUIPMENT FURNISHED BY HOBART/MILLER IS EXCLUDED AND DISCLAIMED BY Hobart/Miller.

Some states in the U.S.A. do not allow limitations of how long an implied warranty lasts, or the exclusion of incidental, indirect, special or consequential damages, so the above limitation or exclusion may not apply to you. This warranty provides specific legal rights, and other rights may be available, but may vary from state to state.

In Canada, legislation in some provinces provides for certain additional warranties or remedies other than as stated herein, and to the extent that they may not be waived, the limitations and exclusions set out above may not apply. This Limited Warranty provides specific legal rights, and other rights may be available, but may vary from province to province.

Warranty Questions?

Call

1-800-332-3281

7 AM – 6 PM EST

Service

You always get the fast, reliable response you need. Most replacement parts can be in your hands in 24 hours.

Support

Need fast answers to the tough welding questions? Contact your distributor or call 1-800-332-3281. The expertise of the distributor and Hobart is there to help you, every step of the way.

Assistance

Visit the Hobart website:
www.HobartWelders.com





Owner's Record

Please complete and retain with your personal records.

Model Name _____ Serial/Style Number _____

Purchase Date _____ (Date which equipment was delivered to original customer.)

Distributor _____

Address _____

City _____

State _____ Zip _____



Resources Available

Always provide Model Name and Serial/Style Number.

To locate a Distributor, retail or service location:

Call 1-877-Hobart1 or visit our website at www.HobartWelders.com

For technical assistance:

Call 1-800-332-3281

Contact your Distributor for:

- Welding Supplies and Consumables
- Options and Accessories
- Personal Safety Equipment
- Service and Repair
- Replacement Parts
- Training (Schools, Videos, Books)
- Technical Manuals (Servicing Information and Parts)
- Circuit Diagrams
- Welding Process Handbooks

Contact the Delivering Carrier to:

File a claim for loss or damage during shipment.

For assistance in filing or settling claims, contact your distributor and/or equipment manufacturer's Transportation Department.

Protect Your Investment!

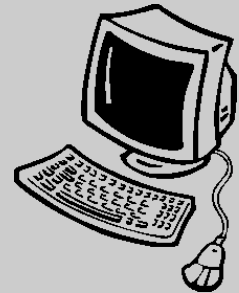

Register your product at:
HobartWelders.com

Hobart Welding Products

An Illinois Tool Works Company
600 West Main Street
Troy, OH 45373 USA

For Technical Assistance:

Call 1-800-332-3281
For Literature Or Nearest Dealer:
Call 1-877-Hobart1

