

SJ-EN Ethernet Communications Option Board Instruction Manual

- SJ300 Series
- L300P Series

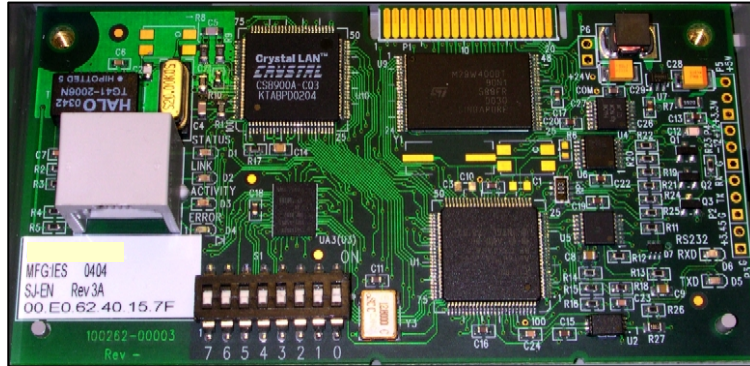

NOTE: REFER ALSO TO SJ300 or L300P SERIES INSTRUCTION MANUAL

Manual Number: HAL1051
December 2004

After reading this manual,
keep it handy for future reference.

Hitachi America, Ltd.

NOTES:

Table of Contents

Table of Contents.....	3
Chapter 1 – General Description	5
Chapter 2 – Installation and Wiring.....	9
Chapter 3 – Configuration.....	13
Chapter 4 – Operation	17
Chapter 5 – Troubleshooting	19
Appendix – Parameter List	20
Index.....	35

NOTES:

Chapter 1 – General Description

The SJ-EN option board is an Ethernet communication interface for the Hitachi SJ300 and L300P series of AC Variable Frequency Inverters. The board can be installed in one of the two available option slots in the inverter.

The SJ-EN uses the open MODBUS/TCP communication protocol. It utilizes a 10Base-T physical interface with a 10 Mbps data transfer rate. Even though the board uses the MODBUS/TCP, this does not necessarily mean that all MODBUS services and functions are supported. Detailed description of the available functionality is provided in Chapter 4 of this manual. The board will act as a MODBUS/TCP slave that can be read from and written to over the Ethernet network from a MODBUS/TCP master device. It will not initiate communication with other devices on the network. It will only respond to requests from a master device. The SJ-EN will allow a user to control the operation of the inverter, monitor its operation, and modify parameters.

Before using this product, please read this manual and the relevant inverter manual, and be sure to follow all safety precautions noted therein. After unpacking the SJ-EN board, carefully inspect it for any defect or damage, and be sure all parts are present.

Carton Contents

- (1) SJ-EN Ethernet Communication Interface Board
- (2) Screws to secure board to inverter case (M3 x 8mm)
- (1) CD-ROM containing this manual (pdf) and NetEdit3 software

WARRANTY

The warranty period under normal installation and handling conditions shall be eighteen (18) months from the date of purchase, or twelve (12) months from the date of installation, whichever occurs first. The warranty shall cover repair or replacement, at Hitachi's sole discretion, of the SJ-EN Option board.

Service in the following cases, even within the warranty period, shall be to the customers account:

1. Malfunction or damage caused by misuse, modification or unauthorized repair.
2. Malfunction or damage caused by mishandling, dropping, etc., after delivery.
3. Malfunction or damage caused by fire, earthquake, flood, lightning, abnormal input voltage, contamination, or other natural disasters.

If service is required for the product at your worksite, all expenses associated with field repair are the purchaser's responsibility. This warranty only covers service at Hitachi designated service facilities.

If making a warranty claims in reference to the above, please contact the distributor from whom you purchased the SJ-EN, and provide the model number, purchase date, installation date, and description of damage or missing components.

SAFETY PRECAUTIONS



HIGH VOLTAGE: This symbol indicates high voltage. It calls your attention to items or operations that could be dangerous to you and other persons operating this equipment. Read the message and follow the instructions carefully.



WARNING: Indicates a potentially hazardous situation that, if not avoided, can result in serious injury or death.



CAUTION: Indicates a potentially hazardous situation that, if not avoided, can result in minor to moderate injury, or serious damage to the product. The situation described in the CAUTION may, if not avoided, lead to serious results. Important safety measures are described in CAUTION (as well as WARNING), so be sure to observe them.



HIGH VOLTAGE: Motor control equipment and electronic controllers are connected to hazardous line voltages. When servicing drives and electronic controllers, there may be exposed components with housings or protrusions at or above line potential. Extreme care should be taken to protect against shock. Stand on an insulating pad and make it a habit to use only one hand when checking components. Always work with another person in case an emergency occurs. Disconnect power before checking controllers or performing maintenance. Be sure equipment is properly grounded. Wear safety glasses whenever working on electronic controllers or rotating machinery.



WARNING: This equipment should be installed, adjusted, and serviced by qualified electrical maintenance personnel familiar with the construction and operation of the equipment and the hazards involved. Failure to observe this precaution could result in bodily injury.



WARNING: HAZARD OF ELECTRICAL SHOCK. DISCONNECT INCOMING POWER BEFORE WORKING ON THIS CONTROL.



WARNING: Wait at least five (5) minutes after turning OFF the input power supply before performing maintenance or an inspection. Otherwise, there is the danger of electric shock.



WARNING: Do not install or remove the SJ-EN Ethernet option board while the inverter is energized. Otherwise there is the danger of electric shock and/or fire.



WARNING: Never modify the unit. Otherwise, there is a danger of electric shock and/or injury.



CAUTION: Be sure to secure the SJ-EN option board with the supplied mounting screws. Make sure all connections are made securely; otherwise there is danger of a loose connection and unpredictable operation.



CAUTION: Alarm connection may contain hazardous live voltage even when inverter is disconnected. When removing the front cover for maintenance or inspection, confirm that incoming power for alarm connection is completely disconnected.



CAUTION: Be sure not to touch the surface or terminals of the SJ-EN Ethernet option board while the inverter is energized; otherwise there is the danger of electric shock.



CAUTION: The software lock modes described in the SJ300 inverter manual are NOT supported via the SJ-EN option board. This means that network commands can bypass any software lock settings configured via the inverter keypad. It is incumbent on the user to make sure no safety lockouts are violated through network commands.



CAUTION: When configuring parameters with the standard keypad, the inverter checks for and inhibits invalid parameter combinations when the STR key is pressed. The SJ-EN bypasses this check, so it is incumbent on the user to make sure invalid configuration parameters or combinations are not sent through network commands. Otherwise undesirable inverter behavior may occur.



CAUTION: Certain parameter data ranges vary depending on model and capacity. The SJ-EN does NOT check to make sure these data are within range. It is incumbent on the user to make sure data for these parameters is within range for the specific model and rating. These parameters are noted in the parameter tables in the Appendix. Otherwise undesirable inverter behavior may occur.

INVERTER COMPATIBILITY

The inverter firmware revision number is embedded within the inverter Manufacturing Number, which can be found on the product nameplate. The SJ-EN Ethernet Interface option board is compatible only with SJ300 and L300P series inverters with Revision Numbers HIGHER than those shown below.

XX8KT XXXXX XXXXX – for SJ300-xxxXFU 0.4 kW (0.5 hp) to 55 kW (75 hp), or L300P-xxxXFU or L300P-xxxXBRM 1.5 kW (2 hp) to 75 kW (100 hp)

XXEMT XXXXX XXXXX – for SJ300-xxxXFU 75kW (100 hp) to 150 kW (200 hp), or L300P-xxxXFU or L300P-xxxXBRM 90 kW (125 hp) to 132 kW (175 hp)

Note: All inverters in the model number series **L300P-xxxXFU₂** are compatible with the SJ-EN, regardless of revision number.

NOTES:

Chapter 2 – Installation and Wiring

Orientation to Product Features

Figure 2-1 below shows the physical layout of the SJ-EN Ethernet option board. In particular, note the location of status LEDs and DIP-switches.

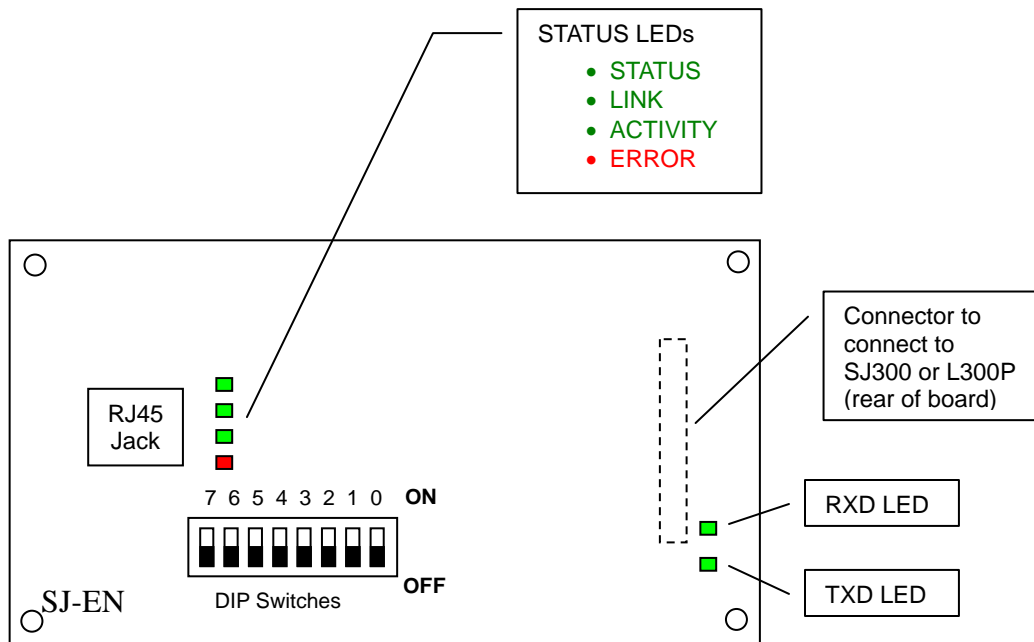

Figure 2-1
SJ-EN Layout

The pinout for the RJ45 connector is as follows:

1. TX Data +
2. TX Data –
3. RX Data +
4. NC
5. NC
6. RX Data –
7. NC
8. NC

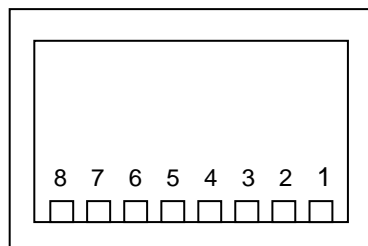

Figure 2-2
SJ-EN RJ45 Pinouts

Installing the Option Board

Power down the inverter and wait at least five minutes before moving to the next step. Open and remove the lower terminal cover. Confirm that the red CHARGE LED is extinguished and that the DC bus is fully discharged before proceeding further, otherwise there is the danger of electric shock. Then remove keypad from the inverter. You can now remove the upper front cover to expose the two option ports inside.

Figure 2-3 below shows how to install the option board to option port 1 or 2 of the inverter. There are four holes on the corners of the option board. Align the board with the port connector in the proper orientation (to the left, when facing the inverter as show). Then align the top two holes with the two screw holes, and the bottom two holes with the two guide posts. Insert the board fully into the connector. Secure the board with the two M3 screws supplied.

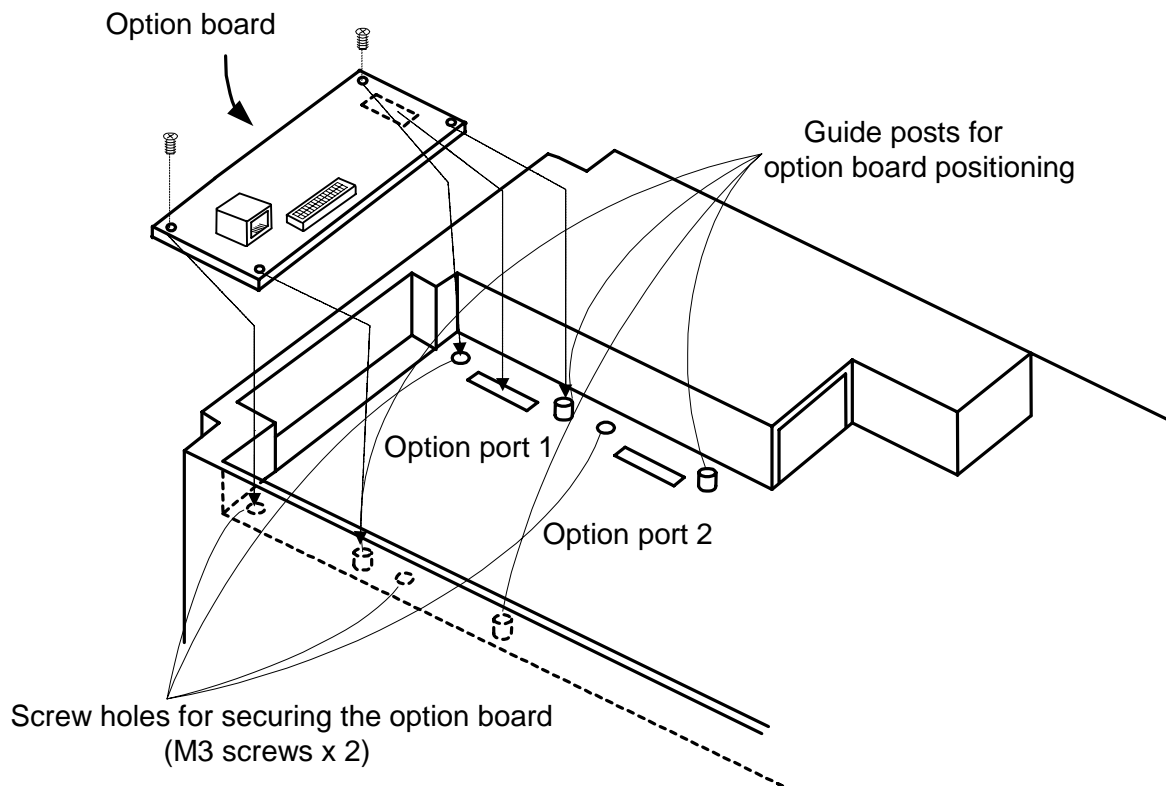

Figure 2-3
Installation of SJ-EN

User Interface

The SJ-EN has six LEDs to convey module status and activity.

Four LEDs next to the RJ45 connector:

- **STATUS (GREEN)** – This LED will be ON whenever the SJ-EN is receiving proper power from the inverter and the self diagnostics have shown the board to be functioning normally.
- **LINK (GREEN)** – This LED is ON when the SJ-EN is receiving valid Ethernet pulses.
- **ACTIVITY (GREEN)** – This LED is ON whenever there is Ethernet traffic in the cable.
- **ERROR (RED)** – This LED will be ON if the SJ-EN has failed due to a hardware watchdog timeout, or the Ethernet communications has been absent for the software watchdog timeout period.

Two LEDs near the right edge of the board:

- **TXD** – This LED indicates communication from the SJ-EN to the inverter through the option port.
- **RXD** – This LED indicates communication to the SJ-EN from the inverter through the option port.

(These two LEDs may appear blinking or may appear steady ON due to the high blink rate.)

NOTES:

Chapter 3 – Configuration

Install NetEdit3 Software

NetEdit3 Software is provided on the CD-R enclosed with the SJ-EN option board. This software is required to configure the board. It can also be used to update the SJ-EN firmware in the event of a future update. NetEdit3 is compatible with Microsoft® Windows® 98, Windows ME, Windows 2000, Windows XP, and Windows NT4.

In Windows, run the program “SetupNE3.exe” on the CD-R to install the program. Follow the on-screen instructions to complete the installation.

Configuration of the SJ-EN Board

Ensure that the SJ-EN is properly installed as described in Chapter 2. Attach a standard Ethernet Crossover cable to the RJ45 connector on the SJ-EN. Connect the other end to the RJ45 port of a Windows PC with an Ethernet adapter installed. If connecting the SJ-EN to a hub, switch or router, use a patch (straight-through) cable instead. For best results, use Category 5, commercial quality cables rated for 10BaseT applications.

There are 8 DIP-switches on the SJ-EN board (see Figure 2-1). Switches 6 and 7 are not used. Switches 0 to 5 may be used to set a 6-bit binary number representing 000001 to 111111 binary or 1 to 63 in decimal, for a device (module) ID. However, for normal Modbus/TCP use, switches 0-5 should all be set to ZERO (off). When configured that way, the device ID is obtained from board’s FLASH memory. The value will be programmed into the SJ-EN flash memory by means of the NetEdit3 software; this ID can be any 32-bit binary value (i.e. 0 to 4,294,967,295 decimal).

Make sure that all wiring is secure in the inverter, and that the power connections are free and clear. Be sure to separate power wiring from control wiring. If they have to be crossed, be sure that they cross at a right angle. Connect the inverter to the PC Ethernet port, and that the PC is started and running Windows. Power up the inverter, and observe the LEDs on the SJ-EN board. The STATUS LED should be illuminated, and the LINK, ACTIVITY, RXD and TXD LEDs should be blinking (may appear as though ON continuously, due to high blink rate). The red ERROR LED should NOT be illuminated. See Chapter 4 for detailed description of LED functions. If the LED conditions are not correct, proceed to Chapter 5 for Troubleshooting. If you power up the inverter before powering up the PC, an error code may appear. After powering up the PC and properly connecting the cable, you should be able to clear the error with the STOP/RESET key on the inverter keypad.

If the LEDs are correct, power down the inverter again. After the inverter CHARGE LED has extinguished, replace the covers on the inverter and reinstall the keypad. Then you can power up the inverter and continue with the configuration.

Set Up the SJ-EN with NetEdit3

With the inverter powered up and the Ethernet cable connected from the SJ-EN to your PC, launch the NetEdit3 program. Figure 3-1 shows the initial screen on program start-up. Should an error code appear on the inverter display at power-up, simply press the STOP/RESET key on the keypad to clear it.

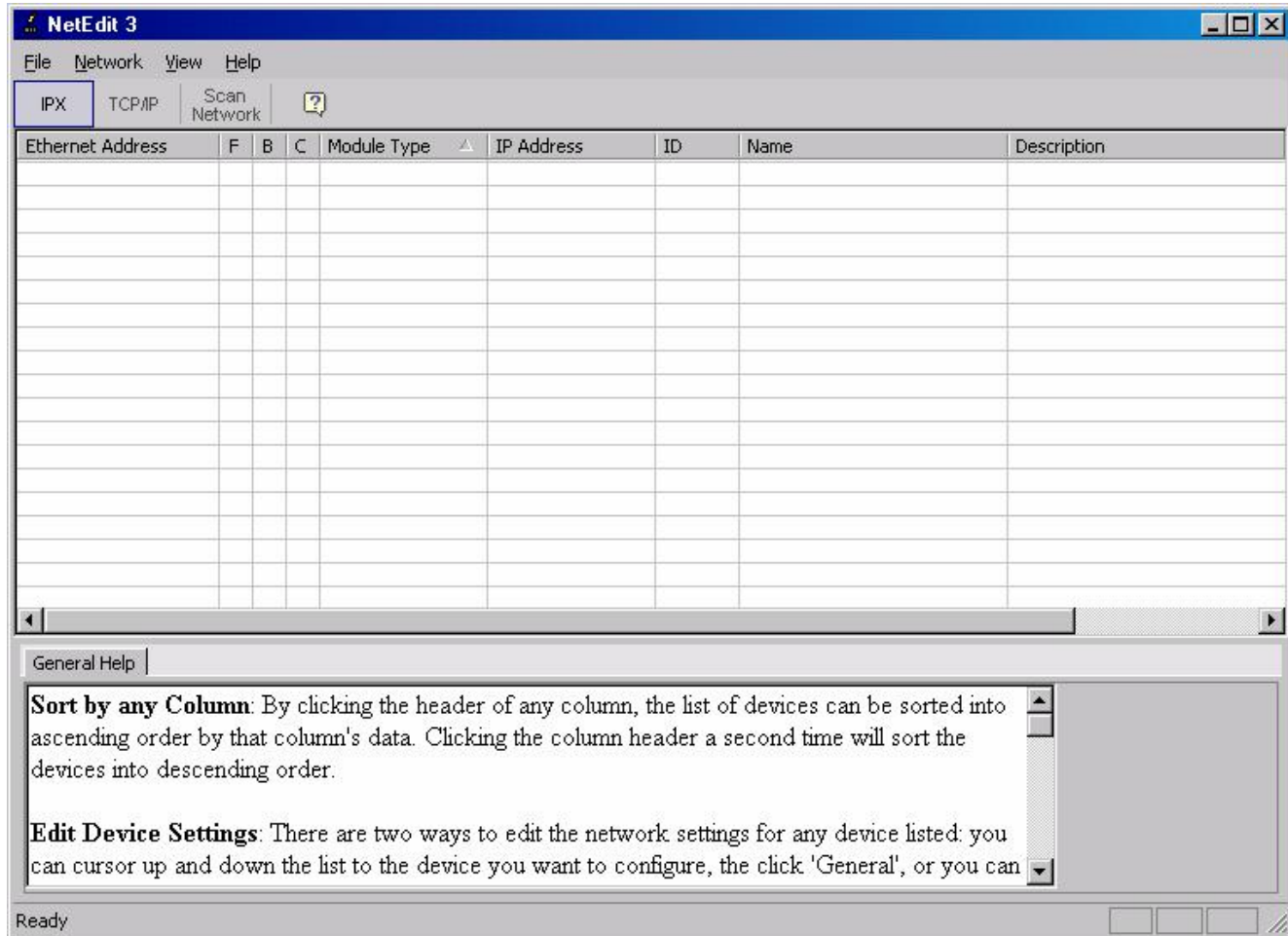

Figure 3-1 NetEdit3 Initial Screen

The NetEdit3 software should find and list any SJ-EN attached to the network. If not, just click on “Scan Network”. An entry will appear in the Device List (grid area), with the board details as shown in Figure 3-2. If more than one board is connected in a common network, you will see a line entry for each of them. The “Module Info” and “General Settings” tabs will now also appear next to the “General Help” tab, below the Device List. You can then click on the line for the board you wish to configure, and click on the “General Settings” tab and then the “General” button to bring up the General Settings dialog box containing the device details, or you can simply double-click on the device in the Device List. In the General Settings dialog box (Figure 3-3), you can enter the Module ID for the device, provided the DIP Switches on the board are all set to zero. Otherwise, the Module ID will reflect the DIP switch setting, and will be grayed out, indicating it cannot be modified with NetEdit3. You can also input a Name for the device, and a Description. The default Name will be “Hitachi Drive”, and the default Description will be “SJ300/L300P Hitachi Drive”.

The device’s IP Address will also be shown. Change this to the desired IP address for your Modbus/TCP network. Your master device will need this address to communicate with this node. Note that all SJ-EN boards ship with the default IP address of “255.255.255.255”. When you change the IP address, the NetEdit3 software may no longer be able to see it in TCP/IP mode if the PC’s IP address is not on the same sub-network. You can communicate to the SJ-EN despite this using the IPX mode, however you will have to make sure IPX support is installed in Windows on that PC.

Once you have made the necessary changes, you can exit NetEdit3, and disconnect the cable from your PC to the SJ-EN board. You may now connect the SJ-EN to your network to begin normal operation.

NOTES:

Chapter 4 – Operation

Setting Up the Inverter for Ethernet Network Operation

Once the SJ-EN board has been properly configured and connected to a network as described in Chapter 3, it is capable of reading data from and writing data to the inverter. However if it is desired to have either the RUN command and/or the speed reference come from the Ethernet master, you must change two inverter parameters as shown in the following table.

Function Code	Name	Description	Run Mode Edit Lo Hi	Defaults			Setting for Ethernet Control
				-FE (EU)	-FU (US)	-FR (Jpn)	
A001	Frequency Source Setting	Six options; select codes: 00 Keypad potentiometer 01 Control terminal 02 Function F001 setting 03 RS485 serial command 04 Expansion board 1 05 Expansion board 2	x x	01	01	01	02
A002	Run command source setting	Five options; select codes: 01 Input terminal [FW] or [RV] (assignable) 02 Run key on keypad, or digital operator 03 RS485 serial command 04 Start/Stop, expansion card #1 05 Start/Stop, expansion card #2	x x	01	01	01	02

Supported MODBUS Functions

The SJ-EN is implemented with the MODBUS/TCP communication protocol. It supports the following MODBUS functions:

- READ MULTIPLE REGISTERS (03) – This function reads the contents of a contiguous block of holding registers in the inverter.
- READ INPUT REGISTERS (04) – This function reads from 1 to up to around 125 contiguous input registers in the inverter.
- WRITE SINGLE REGISTER (06) – This function will write to a single holding register in the inverter.
- WRITE MULTIPLE REGISTERS (16) – This function will write to a block of contiguous registers in the inverter.

Additional MODBUS/TCP protocol details, including specifications, application information, implementation guides, and other resources are available from the web site www.modbus.org.

NOTES:

Chapter 5 – Troubleshooting

In general, the first step to troubleshooting should be to inspect the status LEDs on the SJ-EN board, in addition to the inverter operator/keypad display. These will give valuable clues to the nature of the problem.

In addition, the inverter operator/keypad will provide diagnostic information for certain types of errors. Error codes for the option boards will have the format of:

EXX.X for a board installed in option slot 1, or ***ETX.X*** for a board installed in option slot 2. The number to the right of the decimal point indicates the drive status at the time of trip, as follows:

<i>EXX.0</i>	At reset	<i>EXX.1</i>	At stop	<i>EXX.2</i>	During deceleration
<i>EXX.3</i>	At constant speed	<i>EXX.4</i>	During acceleration	<i>EXX.5</i>	f0 Stop
<i>EXX.6</i>	At starting	<i>EXX.7</i>	During DC injection braking	<i>EXX.8</i>	During overload restriction

The digit immediately to the left of the decimal point has the following meaning:

Code	Trip Name	Cause	Check	Remedy
<i>EX0.X</i>	Ethernet Communication Error	Defective connection	Connectors (plugs & jacks), cable	Replace or repair; press STOP/RESET on inverter keypad
		PC not powered up or not connected to inverter	That PC is powered on and connected	Press STOP/RESET on inverter keypad
		Network configuration error	Verify proper Ethernet setup of SJ-EN and master device	Reconfigure incorrect settings.
<i>EX9.X</i>	Internal Communication Error (between SJ-EN and inverter)	Option board ajar or loose	Verify board is properly seated in connector	Remove and reseal board
		Board lockup	Check status LEDs	Press STOP/RESET key on inverter or cycle power
		Board defective	Check status LEDs	Replace SJ-EN
---	Inverter Mismatch (blinking display as shown)	Inverter firmware version not compatible with SJ-EN option board	Inverter Manufacturing Number for version (see Page 7)	Replace Inverter with later version

NOTES:

Appendix – Parameter List

Note: Parameters in **BOLDFACE** can be edited while inverter is in the **RUN** mode. “RO” means the parameter is Read Only, and “R/W” means the value can be read or written.

Inverter Parameter	Modbus Start Address	Modbus End Address	Parameter Name	Magnitude	Read/Write	Data Range
D – Monitoring Functions						
D001	3001	3002	Output frequency monitor	X1000	RO	0 – 400000
D002	3003	3004	Output current monitor	X10	RO	0 – 10000
D003	3005	3006	Rotation direction monitor	X1	RO	0 – 2
D004	3007	3008	Process Variable (PV) PID feedback monitor	X100	RO	0 – 999900
D005	3009	3010	Intelligent input terminal status	X1	RO	0 – 65535
D006	3011	3012	Intelligent output terminal status	X1	RO	0 – 65535
D007	3013	3014	Scaled output frequency monitor	X1000	RO	0 – 39960000
D012	3023	3024	Output torque monitor	X1	RO	-300 – 300
D013	3025	3026	Output voltage monitor	X10	RO	0 – 10000
D014	3027	3028	Input electric power monitor	X10	RO	0 – 10000
D016	3031	3032	Cumulative RUN time monitor	X1	RO	0 – 4294836225
D017	3033	3034	Cumulative power-on time	X1	RO	0 – 4294836225
D080	3159	3160	Trip counter	X1	RO	0 – 65535
D078	3155	3156	Last trip pointer	X1	RO	0 – 5
D081	3161	3162	Error Code of Trip 1	X1	RO	0 – 255
D355	3709	3710	Frequency at Trip 1	X100	RO	0 – 40000
D356	3711	3712	Output current at Trip 1	X10	RO	0 – 10000
D357	3713	3714	PN voltage (DC voltage) at Trip 1	X10	RO	0 – 10000
D358	3715	3716	Cumulative RUN time at Trip 2	X1	RO	0 – 4294836225
D359	3717	3718	Cumulative power-on time at Trip 2	X1	RO	0 – 4294836225
D082	3163	3164	Error Code of Trip2	X1	RO	0 – 255
D361	3721	3722	Frequency at Trip 2	X100	RO	0 – 40000
D362	3723	3724	Output current of Trip 2	X10	RO	0 – 10000
D363	3725	3726	PN voltage (DC voltage) at Trip2	X10	RO	0 – 10000
D364	3727	3728	Cumulative RUN time at Trip 2	X1	RO	0 – 4294836225
D365	3729	3730	Cumulative power-on time at Trip 2	X1	RO	0 – 4294836225
D083	3165	3166	Error Code of Trip 3	X1	RO	0 – 255

D367	3733	3734	Frequency at Trip 3	X100	RO	0 – 40000
D368	3735	3736	Output current at Trip3	X10	RO	0 – 10000
D369	3737	3738	PN voltage (DC voltage) at Trip 3	X10	RO	0 – 10000
D370	3739	3740	Cumulative RUN time at Trip 3	X1	RO	0 – 4294836225
D371	3741	3742	Cumulative power–on time at Trip 3	X1	RO	0 – 4294836225
D084	3167	3168	Error Code of Trip 4	X1	RO	0 – 255
D373	3745	3746	Frequency at Trip 4	X100	RO	0 – 40000
D374	3747	3748	Output current at Trip 4	X10	RO	0 – 10000
D375	3749	3750	PN voltage (DC voltage) at Trip 4	X10	RO	0 – 10000
D376	3751	3752	Cumulative RUN time at Trip 4	X1	RO	0 – 4294836225
D377	3753	3754	Cumulative power–on time at Trip 4	X1	RO	0 – 4294836225
D085	3169	3170	Error Code of Trip 5	X1	RO	0 – 255
D379	3757	3758	Frequency at Trip 5	X100	RO	0 – 40000
D380	3759	3760	Output current at Trip 5	X10	RO	0 – 10000
D381	3761	3762	PN voltage (DC voltage) at Trip 5	X10	RO	0 – 10000
D382	3763	3764	Cumulative RUN time at Trip 5	X1	RO	0 – 4294836225
D383	3765	3766	Cumulative power–on time at Trip 5	X1	RO	0 – 4294836225
D086	3171	3172	Error Code of Trip 6	X1	RO	0 – 255
D385	3769	3770	Frequency at Trip 6	X100	RO	0 – 40000
D386	3771	3772	Output current at Trip 6	X10	RO	0 – 10000
D387	3773	3774	PN voltage (DC voltage) at Trip 6	X10	RO	0 – 10000
D388	3775	3776	Cumulative RUN time at Trip 6	X1	RO	0 – 4294836225
D389	3777	3778	Cumulative power–on time at Trip 6	X1	RO	0 – 4294836225
D101	3201	3202	Output Frequency Monitor	X1000	RO	0 – 400000
D102	3203	3204	DC Bus Voltage	X10	RO	1 – 10000
D103	3205	3206	Accumulated BRD ON time	X10	RO	1 – 1000
D104	3207	3208	E-Thermal Monitor	X10	RO	1 – 1000
D106	3211	3212	MCU Version	X1	RO	0 – 65535

F – Main Profile Functions

F001	4001	4002	Output frequency setting(Hz) / PID Setpoint (%)	X1000	RO	0 – 400000
F002	4003	4004	Acceleration time 1	X100	R/W	1 – 360000
F202	4403	4404	Acceleration time 1, 2 nd motor	X100	R/W	1 – 360000
F302	4603	4604	Acceleration time 1, 3 rd motor	X100	R/W	1 – 360000
F003	4005	4006	Deceleration time 1	X100	R/W	1 – 360000
F203	4405	4406	Deceleration time 1, 2 nd motor	X100	R/W	1 – 360000
F303	4605	4606	Deceleration time 1, 3 rd motor	X100	R/W	1 – 360000
F004	4007	4008	Keypad RUN key routing	X1	R/W	0 – 1

A – Standard Functions

A001	1	2	Frequency source setting	X1	R/W	0 – 5
A002	3	4	Run command source setting	X1	R/W	1 – 5
A003	5	6	Base frequency setting	X1	R/W	30 – 400
A203	405	406	Base frequency setting, 2 nd motor	X1	R/W	30 – 400
A303	605	606	Base frequency setting, 3 rd motor	X1	R/W	30 – 400
A004	7	8	Maximum frequency setting	X1	R/W	30 – 400
A204	407	408	Maximum frequency setting, 2 nd motor	X1	R/W	30 – 400
A304	607	608	Maximum frequency setting, 3 rd motor	X1	R/W	30 – 400
A005	9	10	[AT] selection	X1	R/W	0 – 1
A006	11	12	[O2] selection	X1	R/W	0 – 3
A011	21	22	[O]–[L] input active range start frequency	X100	R/W	0 – 40000
A012	23	24	[O]–[L] input active range end frequency	X100	R/W	0 – 40000
A013	25	26	[O]–[L] input active range start voltage	X1	R/W	0 – 100
A014	27	28	[O]–[L] input active range end voltage	X1	R/W	0 – 100
A015	29	30	[O]–[L] input start frequency select	X1	R/W	0 – 1
A016	31	32	Analog input filter time constant	X1	R/W	1 – 30
A019	37	38	Multi–speed operation selection	X1	R/W	0 – 1
A020	39	40	Multi–speed frequency 0	X100	R/W	0 – 40000
A220	439	440	Multi–speed frequency 0, 2nd motor	X100	R/W	0 – 40000
A320	639	640	Multi–speed frequency 0, 3rd motor	X100	R/W	0 – 40000
A021	41	42	Multi–speed frequency 1	X100	R/W	0 – 40000

A022	43	44	Multi-speed frequency 2	X100	R/W	0 – 40000
A023	45	46	Multi-speed frequency 3	X100	R/W	0 – 40000
A024	47	48	Multi-speed frequency 4	X100	R/W	0 – 40000
A025	49	50	Multi-speed frequency 5	X100	R/W	0 – 40000
A026	51	52	Multi-speed frequency 6	X100	R/W	0 – 40000
A027	53	54	Multi-speed frequency 7	X100	R/W	0 – 40000
A028	55	56	Multi-speed frequency 8	X100	R/W	0 – 40000
A029	57	58	Multi-speed frequency 9	X100	R/W	0 – 40000
A030	59	60	Multi-speed frequency 10	X100	R/W	0 – 40000
A031	61	62	Multi-speed frequency 11	X100	R/W	0 – 40000
A032	63	64	Multi-speed frequency 12	X100	R/W	0 – 40000
A033	65	66	Multi-speed frequency 13	X100	R/W	0 – 40000
A034	67	68	Multi-speed frequency 14	X100	R/W	0 – 40000
A035	69	70	Multi-speed frequency 15	X100	R/W	0 – 40000
A038	75	76	Jog frequency setting	X100	R/W	0 – 999
A039	77	78	Jog stop mode	X1	R/W	0 – 5
A041	81	82	Torque boost method selection	X1	R/W	0 – 1
A241	481	482	Torque boost method, 2 nd motor	X1	R/W	0 – 1
A042	83	84	Manual torque boost value	X10	R/W	0 – 200
A242	483	484	Manual torque boost value, 2nd motor	X10	R/W	0 – 200
A342	683	684	Manual torque boost value 3rd motor	X10	R/W	0 – 200
A043	85	86	Manual torque boost frequency adjustment	X10	R/W	0 – 500
A243	485	486	Manual torque boost frequency adjustment, 2nd motor	X10	R/W	0 – 500
A343	685	686	Manual torque boost frequency, 3rd motor	X10	R/W	0 – 500
A044	87	88	V/f characteristic curve selection, 1 st motor	X1	R/W	0 – 5 *
A244	487	488	V/f characteristic curve selection, 2 nd motor	X1	R/W	0 – 4 *
A344	687	688	V/f characteristic curve selection, 3 rd motor	X1	R/W	0 – 1
A045	89	90	V/f gain setting	X1	R/W	20 – 100
A051	101	102	DC braking enable	X1	R/W	0 – 1
A052	103	104	DC braking frequency setting	X100	R/W	0 – 6000
A053	105	106	DC braking wait time	X10	R/W	0 – 50
A054	107	108	DC braking force during deceleration	X1	R/W	0 – 100 *
A055	109	110	DC braking time for deceleration	X10	R/W	0 – 600
A056	111	112	Selection of edge/level action of DC braking input [DB]	X1	R/W	0 – 1

A057	113	114	DC braking force for starting	X1	R/W	0 – 100 *
A058	115	116	DC braking time for starting	X10	R/W	0 – 600
A059	117	118	DC braking carrier frequency	X10	R/W	5 – 150 *
A061	121	122	Frequency upper limit setting	X100	R/W	0 – 40000
A261	521	522	Frequency upper limit setting, 2 nd motor	X100	R/W	0 – 40000
A062	123	124	Frequency lower limit setting	X100	R/W	0 – 40000
A262	523	524	Frequency lower limit setting, 2 nd motor	X100	R/W	0 – 40000
A063	125	126	Jump frequency 1	X100	R/W	0 – 40000
A064	127	128	Width of jump frequency 1	X100	R/W	0 – 1000
A065	129	130	Jump frequency 2	X100	R/W	0 – 40000
A066	131	132	Width of jump frequency 2	X100	R/W	0 – 1000
A067	133	134	Jump frequency 3	X100	R/W	0 – 40000
A068	135	136	Width of jump frequency 3	X100	R/W	0 – 1000
A069	137	138	Acceleration pause frequency setting	X100	R/W	0 – 40000
A070	139	140	Acceleration pause time setting	X10	R/W	0 – 600
A071	141	142	PID Enable	X1	R/W	0 – 1
A072	143	144	PID Proportional(P) gain	X10	R/W	2 – 50
A073	145	146	PID Integral (I) time constant	X10	R/W	0 – 36000
A074	147	148	PID Derivative (D) time constant	X100	R/W	0 – 10000
A075	149	150	PID PV Scale conversion	X100	R/W	1 – 9999
A076	151	152	PID PV source setting	X1	R/W	0 – 1
A081	161	162	AVR function select	X1	R/W	0 – 2
A082	163	164	AVR voltage select	X1	R/W	0 = 200 V * 1 = 215 V 2 = 220 V 3 = 230 V 4 = 240 V 5 = 380 V 6 = 400 V 7 = 415 V 8 = 440 V 9 = 460 V 10 = 480 V
A085	169	170	Operation mode selection	X1	R/W	0 – 2 *
A086	171	172	Energy saving mode tuning	X10	R/W	0 – 1000
A092	183	184	Acceleration time (2)	X100	R/W	1 – 360000
A292	583	584	Acceleration time (2), 2nd motor	X100	R/W	1 – 360000
A392	783	784	Acceleration time (2), 3rd motor	X100	R/W	1 – 360000
A093	185	186	Deceleration time (2)	X100	R/W	1 – 360000
A293	585	586	Deceleration time (2), 2nd motor	X100	R/W	1 – 360000
A393	785	786	Deceleration time (2), 3rd motor	X100	R/W	1 – 360000

A094	187	188	Select method to switch to acc2/dec2 profile	X1	R/W	0 – 1
A294	587	588	Select method to switch to acc2/dec2 profile, 2 nd motor	X1	R/W	0 – 1
A095	189	190	Acc1 to Acc2 frequency transition point	X100	R/W	0 – 40000
A295	589	590	Acc1 to Acc2 frequency transition point, 2 nd motor	X100	R/W	0 – 40000
A096	191	192	Dec1 to Dec2 frequency transition point	X100	R/W	0 – 40000
A296	591	592	Dec1 to Dec2 frequency transition point, 2 nd motor	X100	R/W	0 – 40000
A097	193	194	Acceleration curve selection	X1	R/W	0 – 3
A098	195	196	Deceleration curve selection	X1	R/W	0 – 3
A101	201	202	[OI]–[L] input active range start frequency	X100	R/W	0 – 40000
A102	203	204	[OI]–[L] input active range end frequency	X100	R/W	0 – 40000
A103	205	206	[OI]–[L] input active range start current	X1	R/W	0 – 100
A104	207	208	[OI]–[L] input active range end current	X1	R/W	0 – 100
A105	209	210	[OI]–[L] input start frequency enable	X1	R/W	0 – 1
A111	221	222	[O2]–[L] input active range start frequency	X100	R/W	–40000 – 40000
A112	223	224	[O2]–[L] input active range end frequency	X100	R/W	–40000 – 40000
A113	225	226	[O2]–[L] input active range start voltage	X1	R/W	–100 – 100
A114	227	228	[O2]–[L] input active range end voltage	X1	R/W	–100 – 100
A131	261	262	Acceleration curve constant	X1	R/W	1 – 10
A132	263	264	Deceleration curve constant	X1	R/W	1 – 10

B – Fine-Tuning Functions

B001	1001	1002	Selection of automatic restart mode	X1	R/W	0 – 3
B002	1003	1004	Allowable under-voltage power failure time	X10	R/W	3 – 250
B003	1005	1006	Retry wait time before motor restart	X10	R/W	3 – 1000
B004	1007	1008	Instantaneous power failure/under-voltage trip alarm enable	X1	R/W	0 – 2
B005	1009	1010	Number of restarts on power failure/under-voltage events	X1	R/W	0 – 1

B006	1011	1012	Phase loss detection enable	X1	R/W	0 – 1
B007	1013	1014	Restart frequency threshold	X100	R/W	0 – 40000
B012	1023	1024	Level of electronic thermal setting, 1 st motor	X10	R/W	200 – 1200
B212	1423	1424	Level of electronic thermal setting, 2 nd motor	X10	R/W	200 – 1200
B312	1623	1624	Level of electronic thermal setting, 3 rd motor	X10	R/W	200 – 1200
B013	1025	1026	Electronic thermal characteristic, 1 st motor	X1	R/W	0 – 2
B213	1425	1426	Electronic thermal characteristic, 2 nd motor	X1	R/W	0 – 2
B313	1625	1626	Electronic thermal characteristic, 3 rd motor	X1	R/W	0 – 2
B015	1029	1030	Free setting electronic thermal frequency 1	X1	R/W	0 – 400
B016	1031	1032	Free setting electronic thermal current 1	X10	R/W	0 – 10000
B017	1033	1034	Free setting electronic thermal frequency 2	X1	R/W	0 – 400
B018	1035	1036	Free setting electronic thermal current 2	X10	R/W	0 – 10000
B019	1037	1038	Free setting electronic thermal frequency 3	X1	R/W	0 – 400
B020	1039	1040	Free setting electronic thermal current 3	X10	R/W	0 – 10000
B021	1041	1042	Overload restriction operation mode	X1	R/W	0 – 3
B022	1043	1044	Overload restriction setting	X10	R/W	500 – 2000 *
B023	1045	1046	Deceleration rate at overload restriction	X100	R/W	10 – 3000
B024	1047	1048	Selection of method of overload restriction 2	X1	R/W	0 – 3
B025	1049	1050	Overload restriction setting 2	X10	R/W	500 – 2000 *
B026	1051	1052	Deceleration rate at overload restriction 2	X100	R/W	10 – 3000
B031	1061	1062	Software lock mode selection	X1	R/W	0 – 10
B034	1067	1068	Run/power – on warning time	X1	R/W	0 – 65535
B035	1069	1070	Rotational direction restriction	X1	R/W	0 – 2
B036	1071	1072	Reduced voltage start selection	X1	R/W	0 – 6
B037	1073	1074	Function code display restriction	X1	R/W	0 – 2
B040	1079	1080	Torque limit selection	X1	R/W	0 – 4
B041	1081	1082	Torque limit (I) forward driving	X1	R/W	0 – 200 *
B042	1083	1084	Torque limit (II) reverse regen.	X1	R/W	0 – 200 *
B043	1085	1086	Torque limit (III) reverse driving	X1	R/W	0 – 200 *
B044	1087	1088	Torque limit (IV) forward regen.	X1	R/W	0 – 200 *

B045	1089	1090	Torque limit LADSTOP enable	X1	R/W	0 – 1
B046	1091	1092	Reverse run protection enable	X1	R/W	0 – 1
B050	1099	1100	Controlled deceleration and stop on power loss	X1	R/W	0 – 1
B051	1101	1102	DC bus voltage trigger level during power loss	X10	R/W	0 – 10000
B052	1103	1104	Over-voltage threshold during power loss	X10	R/W	0 – 10000
B053	1105	1106	Deceleration time setting during power loss	X100	R/W	1 – 360000
B054	1107	1108	Initial output frequency decrease during power loss	X100	R/W	0 – 1000
B080	1159	1160	[AM] terminal analog meter adjustment	X1	R/W	0 – 255
B081	1161	1162	[FM] terminal analog meter adjustment	X1	R/W	0 – 255
B082	1163	1164	Start frequency adjustment	X100	R/W	10 – 999
B083	1165	1166	Carrier frequency setting	X10	R/W	5 – 150 *
B084	1167	1168	Initialization mode	X1	R/W	0 – 2
B085	1169	1170	Country code for initialization	X1	R/W	0 – 2
B086	1171	1172	Frequency scaling factor	X10	R/W	1 – 999
B087	1173	1174	STOP key enable	X1	R/W	0 – 1
B088	1175	1176	Restart mode after FRS	X1	R/W	0 – 1
B090	1179	1180	Dynamic braking usage ratio	X10	R/W	0 – 1000
B091	1181	1182	Stop mode selection	X1	R/W	0 – 1
B092	1183	1184	Cooling fan control	X1	R/W	0 – 1
B095	1189	1190	Dynamic braking control	X1	R/W	0 – 2
B096	1191	1192	Dynamic braking activation level	X1	R/W	330 – 760 *
B098	1195	1196	Thermistor function	X1	R/W	0 – 2
B099	1197	1198	Thermistor protection level setting	X1	R/W	0 – 9999
B100	1199	1200	Free V/F control frequency 1	X1	R/W	0 – 400
B101	1201	1202	Free V/F control voltage 1	X10	R/W	0 – 8000
B102	1203	1204	Free V/F control frequency 2	X1	R/W	0 – 400
B103	1205	1206	Free V/F control voltage 2	X10	R/W	0 – 8000
B104	1207	1208	Free V/F control frequency 3	X1	R/W	0 – 400
B105	1209	1210	Free V/F control voltage 3	X10	R/W	0 – 8000
B106	1211	1212	Free V/F control frequency 4	X1	R/W	0 – 400
B107	1213	1214	Free V/F control voltage 4	X10	R/W	0 – 8000
B108	1215	1216	Free V/F control frequency 5	X1	R/W	0 – 400
B109	1217	1218	Free V/F control voltage 5	X10	R/W	0 – 8000
B110	1219	1220	Free V/F control frequency 6	X1	R/W	0 – 400
B111	1221	1222	Free V/F control voltage 6	X10	R/W	0 – 8000
B112	1223	1224	Free V/F control frequency 7	X1	R/W	0 – 400

B113	1225	1226	Free V/F control voltage 7	X10	R/W	0 – 8000
B120	1239	1240	Brake control enable	X1	R/W	0 – 1
B121	1241	1242	Brake wait time for release	X100	R/W	0 – 500
B122	1243	1244	Brake wait time for acceleration	X100	R/W	0 – 500
B123	1245	1246	Brake wait time for stopping	X100	R/W	0 – 500
B124	1247	1248	Brake wait time for confirmation	X100	R/W	0 – 500
B125	1249	1250	Brake release frequency setting	X100	R/W	0 – 40000
B126	1251	1252	Brake release current setting	X10	R/W	0 – 2000

C – Intelligent Terminal Functions

C001	2001	2002	Intelligent input 1 function	X1	R/W	1 – 255 *
C002	2003	2004	Intelligent input 2 function	X1	R/W	1 – 255 *
C003	2005	2006	Intelligent input 3 function	X1	R/W	1 – 255 *
C004	2007	2008	Intelligent input 4 function	X1	R/W	1 – 255 *
C005	2009	2010	Intelligent input 5 function	X1	R/W	1 – 255 *
C006	2011	2012	Intelligent input 6 function	X1	R/W	1 – 255 *
C007	2013	2014	Intelligent input 7 function	X1	R/W	1 – 255 *
C008	2015	2016	Intelligent input 8 function	X1	R/W	1 – 255 *
C011	2021	2022	Intelligent input 1 active state	X1	R/W	0 – 1
C012	2023	2024	Intelligent input 2 active state	X1	R/W	0 – 1
C013	2025	2026	Intelligent input 3 active state	X1	R/W	0 – 1
C014	2027	2028	Intelligent input 4 active state	X1	R/W	0 – 1
C015	2029	2030	Intelligent input 5 active state	X1	R/W	0 – 1
C016	2031	2032	Intelligent input 6 active state	X1	R/W	0 – 1
C017	2033	2034	Intelligent input 7 active state	X1	R/W	0 – 1
C018	2035	2036	Intelligent input 8 active state	X1	R/W	0 – 1
C019	2037	2038	FW input active state	X1	R/W	0 – 1
C021	2041	2042	Intelligent output 11 function	X1	R/W	0 – 26 *
C022	2043	2044	Intelligent output 12 function	X1	R/W	0 – 26 *
C023	2045	2046	Intelligent output 13 function	X1	R/W	0 – 26 *
C024	2047	2048	Intelligent output 14 function	X1	R/W	0 – 26 *
C025	2049	2050	Intelligent output 15 function	X1	R/W	0 – 26 *
C026	2051	2052	Alarm relay output function	X1	R/W	0 – 26 *
C027	2053	2054	[FM] signal function	X1	R/W	0 – 7
C028	2055	2056	[AM] signal function	X1	R/W	0 – 7
C029	2057	2058	[AMI] signal function	X1	R/W	0 – 7
C031	2061	2062	Intelligent output 11 active state	X1	R/W	0 – 1
C032	2063	2064	Intelligent output 12 active state	X1	R/W	0 – 1
C033	2065	2066	Intelligent output 13 active state	X1	R/W	0 – 1

C034	2067	2068	Intelligent output 14 active state	X1	R/W	0 – 1
C035	2069	2070	Intelligent output 15 active state	X1	R/W	0 – 1
C036	2071	2072	Alarm relay output active state	X1	R/W	0 – 1
C040	2079	2080	Overload signal output mode	X1	R/W	0 – 1
C041	2081	2082	Overload level setting	X10	R/W	0 – 2000
C042	2083	2084	Frequency arrival setting for acceleration	X100	R/W	0 – 40000
C043	2085	2086	Arrival frequency setting for deceleration	X100	R/W	0 – 40000
C044	2087	2088	PID deviation level setting	X10	R/W	0 – 1000
C045	2089	2090	Frequency arrival setting for acceleration (2)	X100	R/W	0 – 40000
C046	2091	2092	Arrival frequency setting for deceleration (2)	X100	R/W	0 – 40000
C055	2109	2110	Over torque level – quadrant I	X1	R/W	0 – 200 *
C056	2111	2112	Over torque level – quadrant II	X1	R/W	0 – 200 *
C057	2113	2114	Over torque level – quadrant III	X1	R/W	0 – 200 *
C058	2115	2116	Over torque level – quadrant IV	X1	R/W	0 – 200 *
C061	2121	2122	Electronic thermal warning level	X1	R/W	0 – 100
C062	2123	2124	Alarm code output	X1	R/W	0 – 2
C063	2125	2126	Zero speed detection level	X100	R/W	0 – 10000
C070	2139	2140	Data command method	X1	R/W	2 – 5
C071	2141	2142	Communication speed selection	X1	R/W	2 – 6
C072	2143	2144	Node allocation	X1	R/W	1 – 32
C073	2145	2146	Communication data length	X1	R/W	7 – 8
C074	2147	2148	Communication parity selection	X1	R/W	0 – 2
C075	2149	2150	Communication stop bit selection	X1	R/W	1 – 2
C078	2155	2156	Communication wait time	X1	R/W	0 – 1000
C081	2161	2162	[O] input span calibration	X1	R/W	0 – 65535
C082	2163	2164	[OI] input span calibration	X1	R/W	0 – 65535
C083	2165	2166	[O2] input span calibration	X1	R/W	0 – 65535
C085	2169	2170	Thermistor input tuning	X10	R/W	0 – 10000
C086	2171	2172	[AM] output offset	X10	R/W	0 – 100
C087	2173	2174	[AMI] output span	X1	R/W	0 – 255
C088	2175	2176	[AMI] output offset	X10	R/W	0 – 200
C091	2181	2182	Debug mode enable	X1	R/W	0 – 1
C101	2201	2202	UP/DOWN memory mode	X1	R/W	0 – 1
C102	2203	2204	RESET mode selection	X1	R/W	0 – 2
C103	2205	2206	Restart mode after RESET	X1	R/W	0 – 1
C111	2221	2222	Overload setting (2)	X10	R/W	0 – 2000
C121	2241	2242	[O] input zero calibration	X1	R/W	0 – 65535
C122	2243	2244	[OI] input zero calibration	X1	R/W	0 – 65535

C123	2245	2246	[O2] input zero calibration	X1	R/W	0 – 65535
C195	2389	2390	Region code selection	X1	RO	0 – 2
C196	2391	2392	Capacity code selection	X1	RO	1 – 15 *
C197	2393	2394	Voltage code selection	X1	RO	0 – 1
C198	2395	2396	Inverter model series code	X1	RO	0 – 1

H – Motor Constants and Functions

H001	5001	5002	Auto-tuning setting	X1	R/W	0 – 2
H002	5003	5004	Motor data selection, 1 st motor	X1	R/W	0 – 2
H202	5403	5404	Motor data selection, 2 nd motor	X1	R/W	0 – 2
H003	5005	5006	Motor capacity, 1 st motor	X1	R/W	0 – 21 *
H203	5405	5406	Motor capacity, 2 nd motor	X1	R/W	0 – 21 *
H004	5007	5008	Motor poles, 1 st motor	X1	R/W	0 – 3
H204	5407	5408	Motor poles, 2 nd motor	X1	R/W	0 – 3
H005	5009	5010	Motor speed constant, 1st motor	X1000	R/W	1 – 65535
H205	5409	5410	Motor speed constant, 2nd motor	X1000	R/W	1 – 65535
H006	5011	5012	Motor stabilization constant, 1st motor	X1	R/W	0 – 255
H206	5411	5412	Motor stabilization constant, 2nd motor	X1	R/W	0 – 255
H306	5611	5612	Motor stabilization constant, 3rd motor	X1	R/W	0 – 255
H020	5039	5040	Motor constant R1, 1 st motor	X1000	R/W	0 – 65535
H220	5439	5440	Motor constant R1, 2 nd motor	X1000	R/W	0 – 65535
H021	5041	5042	Motor constant R2, 1 st motor	X1000	R/W	0 – 65535
H221	5441	5442	Motor constant R2, 2 nd motor	X1000	R/W	0 – 65535
H022	5043	5044	Inductance L, 1 st motor	X100	R/W	0 – 65535
H222	5443	5444	Inductance L, 2 nd motor	X100	R/W	0 – 65535
H023	5045	5046	lo, 1 st motor	X100	R/W	0 – 65535
H223	5445	5446	lo, 2 nd motor	X100	R/W	0 – 65535
H024	5047	5048	Inertia J, 1 st motor	X1000	R/W	1 – 9999000
H224	5447	5448	Inertia J, 2 nd motor	X1000	R/W	1 – 9999000
H030	5059	5060	Motor constant R1, 1 st motor (Auto)	X1000	R/W	0 – 65535
H230	5459	5460	Motor constant R1, 2 nd motor (Auto)	X1000	R/W	0 – 65535
H031	5061	5062	Motor constant R2, 1 st motor (Auto)	X1000	R/W	0 – 65535
H231	5461	5462	Motor constant R2, 2 nd motor (Auto)	X1000	R/W	0 – 65535
H032	5063	5064	Inductance L, 1 st motor (Auto)	X100	R/W	0 – 65535
H232	5463	5464	Inductance L, 2 nd motor (Auto)	X100	R/W	0 – 65535
H033	5065	5066	lo, 1 st motor (Auto)	X100	R/W	0 – 65535
H233	5465	5466	lo, 2 nd motor (Auto)	X100	R/W	0 – 65535

H034	5067	5068	Inertia J, 1 st motor (Auto)	X1000	R/W	1 – 9999000
H234	5467	5468	Inertia J, 1 st motor (Auto)	X1000	R/W	1 – 9999000
H050	5099	5100	PI proportional gain, 1st motor	X10	R/W	0 – 10000
H250	5499	5500	PI proportional gain, 2nd motor	X10	R/W	0 – 10000
H051	5101	5102	PI integral gain, 1st motor	X10	R/W	0 – 10000
H251	5501	5502	PI integral gain, 2nd motor	X10	R/W	0 – 10000
H052	5103	5104	P Proportional gain, 1st motor	X100	R/W	1 – 1000
H252	5503	5504	P Proportional gain, 2nd motor	X100	R/W	1 – 1000
H060	5119	5120	0Hz SLV limit, 1st motor	X10	R/W	0 – 1000
H260	5519	5520	0Hz SLV limit, 2nd motor	X10	R/W	0 – 1000
H070	5139	5140	Terminal selection PI proportion gain setting	X10	R/W	0 – 10000
H071	5141	5142	Terminal selection PI integral gain setting	X10	R/W	0 – 10000
H072	5143	5144	Terminal selection P proportion gain setting	X100	R/W	1 – 1000

O – Other Functions

O001	8001	8002	Run Mode [0=Stop, 1=Forward, 2=Reverse]	X1	R/W	0 – 2
O002	8003	8004	TRIP Counter	X1	RO	0 – 0
O003	8005	8006	TRIP History 1 Time	X1	RO	0 – 0
O004	8007	8008	TRIP History 1 Cause	X1	RO	0 – 0
O005	8009	8010	TRIP History 1 Freq	X1	RO	0 – 0
O006	8011	8012	TRIP History 1 Current	X1	RO	0 – 0
O007	8013	8014	TRIP History 1 Voltage	X1	RO	0 – 0
O008	8015	8016	TRIP History 2 Time	X1	RO	0 – 0
O009	8017	8018	TRIP History 2 Cause	X1	RO	0 – 0
O010	8019	8020	TRIP History 2 Freq	X1	RO	0 – 0
O011	8021	8022	TRIP History 2 Current	X1	RO	0 – 0
O012	8023	8024	TRIP History 2 Voltage	X1	RO	0 – 0
O013	8025	8026	TRIP History 3 Time	X1	RO	0 – 0
O014	8027	8028	TRIP History 3 Cause	X1	RO	0 – 0
O015	8029	8030	TRIP History 3 Freq	X1	RO	0 – 0
O016	8031	8032	TRIP History 3 Current	X1	RO	0 – 0
O017	8033	8034	TRIP History 3 Voltage	X1	RO	0 – 0
O018	8035	8036	Voltage Class	X1	RO	0 – 0
O019	8037	8038	Inverter Type [1=L100, 2=SJ100, 3=J300, 4=SJ300, 5=L300P]	X1	RO	0 – 0
O020	8039	8040	EEPROM Store flag	X1	R/W	0 – 1
O022	8043	8044	Reset Trip	X1	R/W	0 – 1

P – Expansion Card Functions

P001	6001	6002	Selection of action at option1 error	X1	R/W	0 – 1
P002	6003	6004	Selection of action at option2 error	X1	R/W	0 – 1
P010	6019	6020	Feedback option enable	X1	R/W	0 – 1
P011	6021	6022	Encoder PPR setting	X1	R/W	128 – 65000
P012	6023	6024	Control pulse setting	X1	R/W	0 – 1
P013	6025	6026	Pulse input mode setting	X1	R/W	0 – 3
P014	6027	6028	Home search stop position setting	X1	R/W	0 – 4095
P015	6029	6030	Home search speed setting	X100	R/W	0 – 12000
P016	6031	6032	Home search direction setting	X1	R/W	0 – 1
P017	6033	6034	Home search completion range setting	X1	R/W	0 – 10000
P018	6035	6036	Home search completion delay setting	X100	R/W	0 – 999
P019	6037	6038	Electronic gear set position selection	X1	R/W	0 – 1
P020	6039	6040	Electronic gear ratio numerator	X1	R/W	0 – 9999
P021	6041	6042	Electronic gear denominator	X1	R/W	0 – 9999
P022	6043	6044	Feed forward gain of position control	X100	R/W	0 – 65535
P023	6045	6046	Loop gain of position control	X100	R/W	0 – 10000
P025	6049	6050	Temperature compensation thermistor enable	X1	R/W	0 – 1
P026	6051	6052	Over – speed error detection level	X10	R/W	0 – 1500
P027	6053	6054	Speed deviation error detection level setting	X100	R/W	0 – 12000
P031	6061	6062	Acc/Dec time input selection	X1	R/W	0 – 2
P032	6063	6064	Positioning command input setting	X1	R/W	0 – 2
P044	6087	6088	Communication time – out setting (SJ–DN)	X100	R/W	0 – 9999
P045	6089	6090	Inverter action on communication error (SJ–DN)	X1	R/W	0 – 4
P046	6091	6092	Polled I/O OUTPUT Instance number (SJ–DN)	X1	R/W	20 – 100
P047	6093	6094	Polled I/O INPUT Instance number (SJ–DN)	X1	R/W	70 – 101
P048	6095	6096	Inverter action when Idle mode detected (SJ–DN)	X1	R/W	0 – 4
P049	6097	6098	Motor poles setting for revolutions per minute (SJ–DN)	X1	R/W	0 – 19

R – Reference Codes

R001	7001	7002	Status of Inverter	X1	RO	0 – 360000
R002	7003	7004	Set Frequency	X1	RO	0 – 360000
R004	7007	7008	Output Frequency	X1	RO	0 – 360000
R005	7009	7010	Commanded direction of rotation	X1	R/W	0 – 2
R006	7011	7012	Direction of output rotation	X1	RO	0 – 360000
R007	7013	7014	Output terminals data	X1	RO	0 – 360000
R008	7015	7016	Upper data of input terminals	X1	RO	0 – 360000
R010	7019	7020	Lower data of input terminal	X1	RO	0 – 360000
R011	7021	7022	Rated output current	X1	RO	0 – 360000

* Data Range depends on Model and/or Rating. Verify that data you are writing is valid for the inverter model and rating you are writing to.

Index

A

A - Standard Functions · 23
Activity LED · 11
address, Ethernet · 14

B

B - Fine-Tuning Functions · 26

C

C - Intelligent Terminal Functions · 29
cable, Ethernet · 13
Carton Contents · 5
Compatibility, Inverter · 7
Configuration · 13

D

D - Monitoring Functions · 21
device ID · 13
DIP-switches · 9, 13

E

error codes · 19
Error LED · 11
Ethernet address · 14

F

F - Main Profile Functions · 23

H

H - Motor Constants and Functions · 31

I

Installing · 10
Interface, User · 11
IP address · 14

K

keypad, inverter · 19

L

layout, board · 9
LEDs · 9, 11, 13
Link LED · 11

M

MODBUS Functions, supported · 17
module ID · 13, 14

N

NetEdit3 Software · 13
network operation · 17

O

O - Other Functions · 32
Operation · 17

P

P - Expansion Card Functions · 33
parameter list · 21
parameters, inverter · 17
pinout, RJ45 · 9

R

R - Reference Codes · 34
Registers, reading and writing · 17
RJ45 connector · 9
RXD LED · 11

S

Safety Precautions · 6
software · 13

Status LED · 11

T

Troubleshooting · 19
TXD LED · 11

W

Warranty · 5
Wiring · 9