

PARTS AND OPERATION MANUAL

STOW

A DIVISION OF MULTIQUIP INC.

PORTO MIX MINI CONCRETE MIXER PLASTIC DRUM MODELS SMC3PE AND SMC3PB

© COPYRIGHT 2003, MULTIQUIP INC.

Revision #0 (08/08/03)

STOW
A DIVISION OF MULTIQUIP INC.

STOW CONSTRUCTION EQUIPMENT

A DIVISION OF MULTIQUIP INC.

POST OFFICE BOX 6254

CARSON, CA 90749

310-537-3700 • 888-252-STOW [888-252-7869]

FAX: 310-537-1986 • FAX: 800-556-1986

E-MAIL: stow@multiquip.com • WWW: stowmfg.com

PARTS DEPARTMENT:

800-427-1244

FAX: 800-672-7877

SERVICE DEPARTMENT/TECHNICAL ASSISTANCE:

800-478-1244

FAX: 310-631-5032



WARNING



CALIFORNIA — Proposition 65 Warning

Engine exhaust and some of its constituents, and some dust created by power sanding, sawing, grinding, drilling and other construction activities contains chemicals known to the State of California to cause cancer, birth defects and other reproductive harm. Some examples of these chemicals are:

- Lead from lead-based paints.
- Crystalline silica from bricks.
- Cement and other masonry products.
- Arsenic and chromium from chemically treated lumber.

Your risk from these exposures varies, depending on how often you do this type of work. To reduce your exposure to these chemicals: **ALWAYS** work in a well ventilated area, and work with approved safety equipment, such as dust masks that are specially designed to filter out microscopic particles.

HERE'S HOW TO GET HELP

*PLEASE HAVE THE MODEL AND SERIAL NUMBER
ON-HAND WHEN CALLING*

PARTS DEPARTMENT

800-427-1244 or 310-537-3700

FAX: 800-672-7877 or 310-637-3284

SERVICE DEPARTMENT

800-478-1244

FAX: 310- 537-4259

TECHNICAL ASSISTANCE

800-478-1244

FAX: 310- 631-5032

WARRANTY DEPARTMENT

888-661-4279, or 310-661-4279

FAX: 310- 537-1173

Here's How To Get Help 3
 Table Of Contents 4
 Parts Ordering Procedures 5

STOW PORTO MIXER — Portable Concrete Mixer

Safety Message Alert Symbols 6-7
 Rules For Safe Operation 8-10
 Operation and Safety Decals 11-12
 Specifications 13
 Dimensions (Mixer) 14
 Dimensions (Electric Motor) 15
 General Information 16
 Mixer Components 17
 Basic Engine 18
 Assembly Instructions 19-20
 Pre-Inspection (Gasoline Engine) 21
 Initial Start-up (Electric Motor) 22
 Initial Start-up (Gasoline Engine) 23-24
 Maintenance 25-27
 Preparation for Long-Term Storage 28
 Troubleshooting (Engine) 30
 Troubleshooting (Engine/Mixer) 31
 Explanation Of Code In Remarks Column 32
 Suggested Spare Parts 33
 Nameplate and Decals 34-35
 Mixer Assembly (Plastic Drum) 36-39

 Terms and Conditions of Sale 40

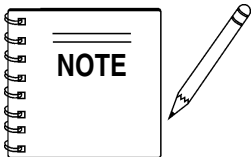

***Specification and part number
 are subject to change without
 notice.***

PARTS ORDERING PROCEDURES

When ordering parts, please supply the following information:

- Dealer account number
- Dealer name and address
- Shipping address (if different than billing address)
- Return fax number
- Applicable model number
- Quantity, part number and description of each part
- Specify preferred method of shipment:
 - ✓ FedEx or UPS Ground
 - ✓ FedEx or UPS Second Day or Third Day
 - ✓ FedEx or UPS Next Day
 - ✓ Federal Express Priority One
 - ✓ DHL
 - ✓ Truck

Note: Unless otherwise indicated by customer, all orders are treated as "Standard Orders", and will ship within 24 hours. We will make every effort to ship "Air Shipments" the same day that the order is received, if prior to 2PM west coast time. "Stock Orders" must be so noted on fax or web forms.



Here's how to get help...

Please have the model and serial number on hand when calling.

Parts Department

800-427-1244 Fax: 800-672-7877
310-537-3700 Fax: 310-637-3284

Service Department

800-478-1244 Fax: 310-537-4259
310-537-3700

Warranty Department

800-421-1244, Ext. 279 Fax: 310-537-1173
310-537-3700, Ext. 279

Sales Department

310-661-4242 Fax: 310-604-9237
877-289-7869 (877-BUY-STOW)

Place Your Parts Order Via Web or Fax For Even More Savings!

Extra Discounts!

All parts orders which include complete part numbers and are received by our automated web parts order system, or by fax qualify for the following extra discounts:

Ordered via	Standard orders	Stock orders (\$750 list and above)
Fax	3%	10%
Web	5%	10%

Special freight allowances when you order 10 or more line items via Web or Fax! **

FedEx Ground Service **at no charge for freight**
No other allowances on freight shipped by any other carrier.

NOTE: DISCOUNTS ARE SUBJECT TO CHANGE

STOW
A DIVISION OF MULTIQUIP INC.

STOW CONSTRUCTION EQUIPMENT

A DIVISION OF MULTIQUIP INC.

POST OFFICE BOX 6254

CARSON, CA 90749

310-537-3700 • 888-252-STOW [888-252-7869]

FAX: 310-537-1986 • FAX: 800-556-1986

E-MAIL: stow@multiquip.com • WWW: stowmfg.com

**Direct TOLL-FREE access
to our Parts Department:**

Toll-free nationwide — 800-427-1244

STOW PORTO MIXER— SAFETY MESSAGE ALERT SYMBOLS

FOR YOUR SAFETY AND THE SAFETY OF OTHERS!

Safety precautions should be followed at all times when operating this equipment. Failure to read and understand the Safety Messages and Operating Instructions could result in injury to yourself and others.

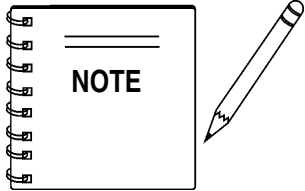

This Owner's Manual has been developed to provide complete instructions for the safe and efficient operation of the **STOW Models SMC3PE and SMC3PB Portable Concrete Mixers**. **Before using these mixers, ensure that the operating individual has read and understands all instructions in this manual.**

SAFETY MESSAGE ALERT SYMBOLS

The three (3) Safety Messages shown below will inform you about potential hazards that could injure you or others. The Safety Messages specifically address the level of exposure to the operator, and are preceded by one of three words: **DANGER**, **WARNING**, or **CAUTION**.



DANGER: You **WILL** be **KILLED** or **SERIOUSLY** injured if you do not follow directions.



WARNING: You **CAN** be **KILLED** or **SERIOUSLY** injured if you do not follow directions.



CAUTION: You **CAN** be injured if you do not follow directions.

Potential hazards associated with the **STOW PORTO MIXER** operation will be referenced with Hazard Symbols which appear throughout this manual, and will be referenced in conjunction with Safety Message Alert Symbols.

HAZARD SYMBOLS

Rotating Parts



NEVER operate equipment with covers, or guards removed. Keep fingers, hands, hair and clothing away from all moving parts to prevent injury.

Accidental Starting



OFF **ALWAYS** place the circuit breaker or power ON/OFF switch in the **OFF** position when the pump is not in use.

Sight and Hearing hazard

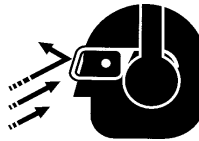

ALWAYS wear approved eye and hearing protection.

Respiratory Hazard



ALWAYS wear approved respiratory protection.

Equipment Damage Messages

Other important messages are provided throughout this manual to help prevent damage to your pump, other property, or the surrounding environment.

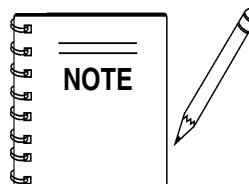

This mixer, other property, or the surrounding environment could be damaged if you do not follow instructions.

STOW PORTO MIXER— SAFETY MESSAGE ALERT SYMBOLS



Accidental Starting



OFF

ALWAYS place the engine ON/OFF switch in the **OFF** position, and remove the ignition key when the machine is not in use.



Respiratory Hazard



ALWAYS wear approved respiratory protection.



Sight and Hearing hazard

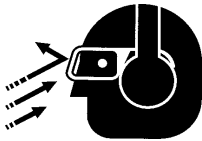

ALWAYS wear approved eye and hearing protection.



Equipment Damage Messages

Other important messages are provided throughout this manual to help prevent damage to your mixer, other property, or the surrounding environment.

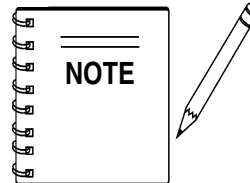

This mixer, other property, or the surrounding environment could be damaged if you do not follow instructions.

RULES FOR SAFE OPERATION

DANGER:



Failure to follow instructions in this manual may lead to serious injury or even death! This equipment is to be operated by trained and qualified personnel only! This equipment is for industrial use only.

The following safety guidelines should always be used when operating the **Porto Mixer**.

GENERAL SAFETY

- **DO NOT** operate or service this equipment before reading this entire manual.



- This equipment should not be operated by persons under 18 years of age.

- **NEVER** operate this equipment without proper protective clothing, shatterproof glasses, steel-toed boots and other protective devices required by the job.



- **NEVER** operate this equipment when not feeling well due to fatigue, illness or taking medicine.



- **NEVER** operate this equipment under the influence of drugs or alcohol.



- Whenever necessary, replace nameplate, operation and safety decals when they become difficult read.

- **ALWAYS** check the machine for loosened threads or bolts before starting.

- **ALWAYS** wear proper respiratory (mask) hearing and eye protection equipment when operating the mixer.



- **NEVER** touch the hot exhaust manifold, muffler or cylinder. Allow these parts to cool before servicing engine or mixer.



- **High Temperatures** – Allow the engine to cool before adding fuel or performing service and maintenance functions. Contact with *hot* components can cause serious burns.

- The engine of this mixer requires an adequate free flow of cooling air. **NEVER!** operate the mixer in any enclosed or narrow area where free flow of the air is restricted. If the air

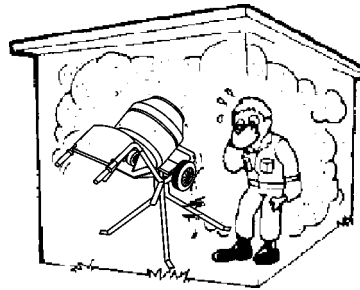

flow is restricted it will cause serious damage to the mixer or engine and may cause injury to people and property. Remember the mixer's engine (gasoline models only) gives off **DEADLY** gases.

- **ALWAYS** refuel in a well-ventilated area, away from sparks and open flames.

- **ALWAYS** use extreme caution when working with **flammable** liquids. When refueling, **stop the engine** and allow it to cool. **DO NOT** smoke around or near the machine. Fire or explosion could result from fuel vapors, or if fuel is spilled on a hot engine.

- **NEVER** operate the mixer in an explosive atmosphere or near combustible materials. An explosion or fire could result causing severe **bodily harm or even death**.

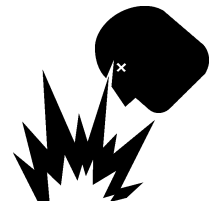

- Topping-off to filler port is dangerous, as it tends to spill fuel.

- Refer to the **Engine Owner's Manual** for engine technical questions or information.

- **NEVER** use accessories or attachments, which are not recommended by **STOW** for this equipment. Damage to the equipment and/or injury to user may result.

- Manufacturer does not assume responsibility for any accident due to equipment modifications.

RULES FOR SAFE OPERATION

- **NEVER** Run engine without air cleaner. Severe engine damage may occur.
- **ALWAYS** read, understand, and follow procedures in Operator's Manual before attempting to operate equipment.
- **ALWAYS** be sure the operator is familiar with proper safety precautions and operations techniques before using roller.
- **ALWAYS** store equipment properly when it is not being used. Equipment should be stored in a clean, dry location out of the reach of children.
- **NEVER** leave the mixer unattended, turn off engine or electric motor when unattended.
- **CAUTION** must always be observed while servicing this mixer. Rotating parts can cause injury if contacted.
- Unauthorized equipment modifications will void all warranties.
- Ensure that any trailing cable is protected against damage and not liable to be tripped over or trapped underneath the mixer.
- Ensure any extension cables must be no longer than 30 meters (100 feet) in length and that the wire section is 2.5 mm².
- **DO NOT** allow extension cord to come into contact with water or fluids.
- **DO NOT** spray water onto electric motor.
- **DO NOT** expose power tools to *rain* or *wet* conditions.
- This mixer is intended for the production of concrete, mortar and plaster. Mixer must be used only for its intended purpose.
- This mixer is not suitable for the mixing of *flammable* or *explosive* substances.
- **NEVER** operate the mixer in an *explosive* atmosphere.
- Before starting the mixer, check that all *guards* are in position and correctly fitted.
- **DO NOT** tip mixer onto drum mouth when the motor is running.
- Keep area around the mixer *clear of obstructions* which could cause persons to fall onto *moving parts*.
- **ALWAYS** ensure mixer is on level ground before mixing.
- Become familiar with the controls of the machine before operating.
- **ALWAYS** replace any worn or damaged warning decals.
- Ensure the drum is *rotating* while filling and emptying the drum.
- **ALWAYS** disconnect AC power plug from power source before moving mixer (electric model only).
- **High Temperatures** – Always stop engine and allow the engine to cool before adding fuel, oil or performing service and maintenance functions. Contact with *hot* components can cause serious burns.
- **NEVER** disconnect any "*emergency or safety devices*". These devices are intended for operator safety. Disconnection of these devices can cause severe injury, bodily harm or even death! Disconnection of any of these devices will void all warranties.
- If mixer is equipped with an electric motor, operate *only* at 120 VAC, 60 Hz.
- Make sure the **OFF/ON** power switch is always in the **OFF** position before inserting the mixer's power plug into an AC receptacle (electric model only).

Maintenance Safety

- **NEVER** lubricate components or attempt service on a running machine.
- **ALWAYS** allow the machine a proper amount of time to cool before servicing.
- Keep the machinery in proper running condition.
- Fix damage to the machine immediately and always replace broken parts, or missing decals.
- Dispose of hazardous waste properly. Examples of potentially hazardous waste are used motor oil, fuel and fuel filters.
- **DO NOT** use food or plastic containers to dispose of hazardous waste.
- **DO NOT** pour waste, oil or fuel directly onto the ground, down a drain or into any water source.

Emergencies

- **ALWAYS** know the location of the nearest *fire extinguisher*.



- **ALWAYS** know the location of the nearest *first aid kit*.

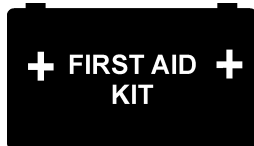

- In emergencies *always* know the location of the nearest phone or **keep a phone on the job site**. Also know the phone numbers of the nearest **ambulance**, **doctor** and **fire department**. This information will be invaluable in the case of an emergency.

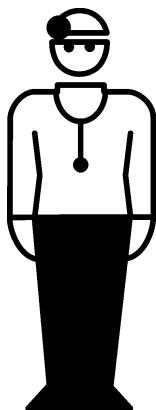
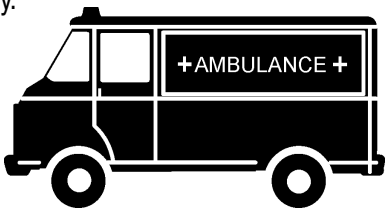

OPERATION AND SAFETY DECALS

Machine Safety Decals

The **STOW PORTO MIXER** is equipped with a number of safety decals. These decals are provided for operator safety and maintenance information. The illustration below and on the next page shows these decals as they appear on the machine. Should any of these decals become unreadable, replacements can be obtained from your dealer.



P/N: DCL300



(Decal is Molded Into Tub)

OPERATION AND SAFETY DECALS

⚠ WARNING!	⚠ ADVERTENCIA!	⚠ AVERTISSEMENT!																																				
<ol style="list-style-type: none"> 1. Read owner's manual before operating mixer. 2. Keep unauthorized and untrained people away from mixer during operation. 3. Make sure all safety devices (guards) are in place before mixer is started. 4. Keep hands and fingers away from moving objects. 5. NEVER leave mixer unattended when operating. 6. ALWAYS check V-belt before starting mixer. 	<ol style="list-style-type: none"> 1. Lea el manual de operación antes de usar la mezcladora. 2. Mantenga personas que no estén autorizadas o capacitadas alejadas de la mezcladora durante el funcionamiento de la máquina. 3. Asegúrese que todos los aparatos de seguridad estén trabajando apropiadamente antes de usar la mezcladora. 4. Mantenga las manos y dedos alejados de objetos en movimiento. 5. NUNCA se aleje de la mezcladora mientras ésta, este trabajando! 6. SIEMPRE inspeccione la banda antes de encender la mezcladora. 	<ol style="list-style-type: none"> 1. Lisez le manuel d' utilisation avant d' utiliser le malaxeur. 2. Seul un personnel qualifié peut être autorisé à se trouver à proximité du malaxeur quand il est en opération. 3. Assurez vous que tous les dispositifs de sécurité sont en place avant de mettre le malaxeur en marche. 4. Gardez les mains et doigts loin de toute pièce en mouvement. 5. NE LAISSEZ jamais le malaxeur sans surveillance quand il est en opération. 6. VEUILLEZ toujours vérifier la courroie avant de mettre le malaxeur en marche. 																																				
<p>GASOLINE ENGINE</p> <ul style="list-style-type: none"> • Make sure engine is turned off and spark plug wire is disconnected before cleaning mixer. • DO NOT operate mixer in an enclosed area, proper ventilation is required. • ALWAYS stop the engine and allow engine to cool before adding fuel or oil. • ALWAYS check fuel, oil and air filter before starting engine. 	<p>MÁQUINAS DE GASOLINA</p> <ul style="list-style-type: none"> • Asegure que la máquina este apagada y el alambre de la bujía este desconectado antes de empezar a limpiar la mezcladora. • NO encienda la mezcladora en una área cerrada; es necesario estar en una área que tenga apropiada ventilación. • SIEMPRE apague la máquina y permita que se enfrie antes de ponerle gasolina o aceite. • SIEMPRE revise la gasolina, aceite, y el filtro del air antes de encender la máquina. 	<p>MOTEUR À ESSENCE</p> <ul style="list-style-type: none"> • Assurez vous que le moteur est arrêté et que le fil de la bougie est débranché avant de nettoyer le malaxeur. • N' UTILISEZ pas le malaxeur dans un endroit fermé, il est nécessaire de travailler dans un endroit avec une bonne aération. • VEUILLEZ toujours vé la courroie avant de mettre le malaxeur en marche. • VÉRIFIEZ toujours le niveau d'essence et d'huile ainsi que le filtre à air avant de mettre le moteur en marche. 																																				
<p>ELECTRIC MOTOR</p> <ul style="list-style-type: none"> • Make sure power cord has been disconnected from power source before cleaning mixer. • This electric motor is for 115 VAC operation only. • ALWAYS use an extension cord of proper size, see chart below: <table border="1" style="width: 100%; text-align: center;"> <thead> <tr> <th colspan="4">EXTENSION CORD SIZE</th> </tr> <tr> <th>No. 12 Wire</th> <th>No. 10 Wire</th> <th>No. 8 Wire</th> <th>No. 6 Wire</th> </tr> </thead> <tbody> <tr> <td>50 feet (15.24 meters)</td> <td>75 feet (22.86 meters)</td> <td>100 feet (30.48 meters)</td> <td>200 feet (60.96 meters)</td> </tr> </tbody> </table>	EXTENSION CORD SIZE				No. 12 Wire	No. 10 Wire	No. 8 Wire	No. 6 Wire	50 feet (15.24 meters)	75 feet (22.86 meters)	100 feet (30.48 meters)	200 feet (60.96 meters)	<p>MOTOR ELÉCTRICO</p> <ul style="list-style-type: none"> • Asegúrese que el cable de corriente esté de empezar a limpiar la mezcladora. • Este motor eléctrico está solamente capacitado para corriente alterna de 115 voltios. • SIEMPRE use el tamaño de extensiones de alambre indicado como muestra el diagrama abajo: <table border="1" style="width: 100%; text-align: center;"> <thead> <tr> <th colspan="4">TAMAÑO DE EXTENSIÓN</th> </tr> <tr> <th>Alambre Número 12</th> <th>Alambre Número 10</th> <th>Alambre Número 8</th> <th>Alambre Número 6</th> </tr> </thead> <tbody> <tr> <td>50 pies (15.24 metros)</td> <td>75 pies (22.86 metros)</td> <td>100 pies (30.48 metros)</td> <td>200 pies (60.96 metros)</td> </tr> </tbody> </table>	TAMAÑO DE EXTENSIÓN				Alambre Número 12	Alambre Número 10	Alambre Número 8	Alambre Número 6	50 pies (15.24 metros)	75 pies (22.86 metros)	100 pies (30.48 metros)	200 pies (60.96 metros)	<p>MOTEUR ÉLECTRIQUE</p> <ul style="list-style-type: none"> • Assures vous toujours que le cable a été débranché de la prise de courant avant de nettoyer le malaxeur. • Ce moteur électrique à été conçu pour opération à 115 volts seulement. • Il faut toujours utiliser une rallonge de taille appropriée, veuillez s'il vous référer au diagramme suivant: <table border="1" style="width: 100%; text-align: center;"> <thead> <tr> <th colspan="4">TAILLE DE LA RALLONGE</th> </tr> <tr> <th>Cable Numéro 12</th> <th>Cable Numéro 10</th> <th>Cable Numéro 8</th> <th>Cable Numéro 6</th> </tr> </thead> <tbody> <tr> <td>50 pieds (15.24 mètres)</td> <td>50 pieds (15.24 mètres)</td> <td>50 pieds (15.24 mètres)</td> <td>50 pieds (15.24 mètres)</td> </tr> </tbody> </table>	TAILLE DE LA RALLONGE				Cable Numéro 12	Cable Numéro 10	Cable Numéro 8	Cable Numéro 6	50 pieds (15.24 mètres)	50 pieds (15.24 mètres)	50 pieds (15.24 mètres)	50 pieds (15.24 mètres)
EXTENSION CORD SIZE																																						
No. 12 Wire	No. 10 Wire	No. 8 Wire	No. 6 Wire																																			
50 feet (15.24 meters)	75 feet (22.86 meters)	100 feet (30.48 meters)	200 feet (60.96 meters)																																			
TAMAÑO DE EXTENSIÓN																																						
Alambre Número 12	Alambre Número 10	Alambre Número 8	Alambre Número 6																																			
50 pies (15.24 metros)	75 pies (22.86 metros)	100 pies (30.48 metros)	200 pies (60.96 metros)																																			
TAILLE DE LA RALLONGE																																						
Cable Numéro 12	Cable Numéro 10	Cable Numéro 8	Cable Numéro 6																																			
50 pieds (15.24 mètres)	50 pieds (15.24 mètres)	50 pieds (15.24 mètres)	50 pieds (15.24 mètres)																																			
<div style="display: flex; justify-content: space-between;"> <div style="width: 30%;">  <p>ELECTRIC MOTOR MOTOR ELÉCTRICO MOTEUR ÉLECTRIQUE</p> <p>REMOVE BOLT AND FILL WITH EP. 90 GEAR OIL REMOVER EL TORÑILLO Y LLENAR CON ACEITE DE ENGRNAJE EP. 90 ÔTEZ LE BOULON ET REMPLISSEZ AVEC DE L'HUILE EP. 90 À ENGRNAGES</p> <p>CHECK DAILY REVISAR DIARIO VÉRIFIEZ QUOTIDIENNEMENT</p> </div> <div style="width: 30%; text-align: center;">  </div> <div style="width: 30%;">  <p>ELECTRIC MOTOR MOTOR ELÉCTRICO MOTEUR ÉLECTRIQUE</p> <p>NEVER! OPERATE MIXER WITH V-BELT COVER REMOVED. NUNCA! MANEJE LA MEZCLADORA SIN LA COBERTURA DE BANDA-V REMOVIDA. N' UTILISEZ! JAMAIS LE MALAXEUR SANS LE COUVERCLE DE LA COURROIE.</p> </div> </div>			DCL250																																			

P/N DCL250

STOW PORTO MIXER— SPECIFICATIONS

Table 1. Specifications (Engine & Electric Motor)

	Model	BRIGGS & STRATTON 91200	BALDOR 17LYE304
Engine/Electric Motor	Type	4-stroke, Vertical valve, Single Cylinder	3/4 HP, 120 VAC, Single Phase Electric Motor
	Bore X Stroke	2.56 in. x 1.75 in. (65.1 mm x 44.4 mm)	N/A
	Displacement	9.0 cu. in. (148 cc)	N/A
	Max Output	3.5 HP at 3,600 R.P.M.	3/4 H.P./3,450 RPM
	Standard Idle Speed	1,800 ± 100 R.P.M.	N/A
	Fuel Tank Capacity	Approx. 0.5 U.S. Gallons (1.89 Liters)	N/A
	Fuel	Unleaded Gasoline	N/A
	Lube Oil Capacity	2 U.S. Quarts (1.89 Liters)	N/A
	Speed Control Method	Centrifugal Fly-weight Type	N/A
	Starting Method	Recoil Start	N/A
	Dimensions (L x W x H)	12.5 x 11.47 x 12.18 in. (317.5 x 291.4 x 309.4 mm)	11.75 x 6.0 X 8.0 in. (298 X 152 X 203 mm)
Dry Net Weight	20.3 lbs (9.2 kg)	Approx. 12 lbs. (5.4 Kg.)	

Table 2. Porto Mixer Specifications

Height	34 in. (863.6 mm)
Width	23-5/8 in. (584.2 mm)
Length	48-1/2 in. (1,219.2 mm)
Stand Weight	35 lbs. (15.9 Kg)
Maximum Drum Capacity	4.5 cu. ft. (0.13 m ³)
Maximum Mixing Capacity (1/2 bag)	3.0 cu. ft. (0.08 m ³)
Unladen Weight - Electric Motor	129 lbs. (58.5 Kg)
Unladen Weight - Gasoline Engine	138 lbs. (62.6 Kg)

STOW PORTO MIXER— DIMENSIONS (MIXER)

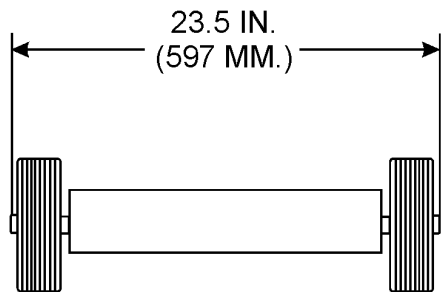
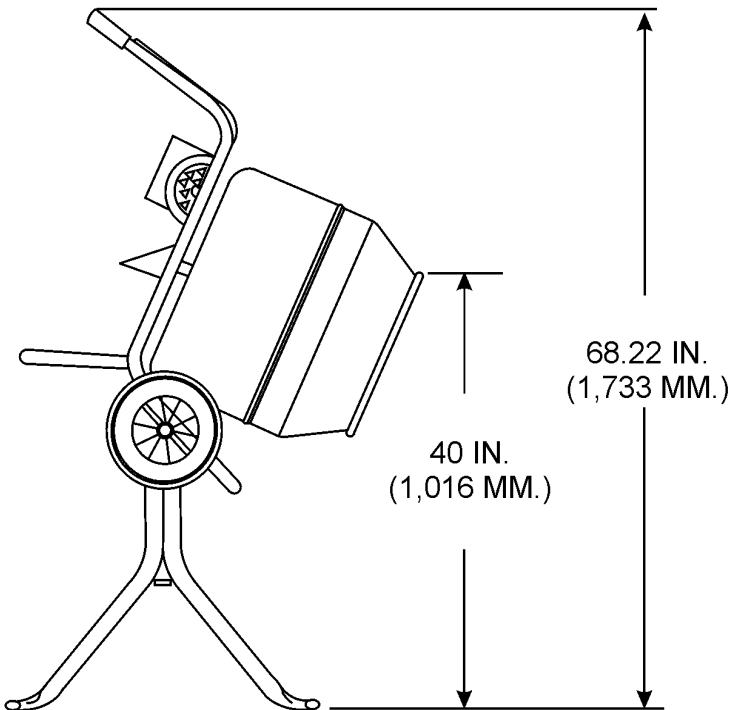
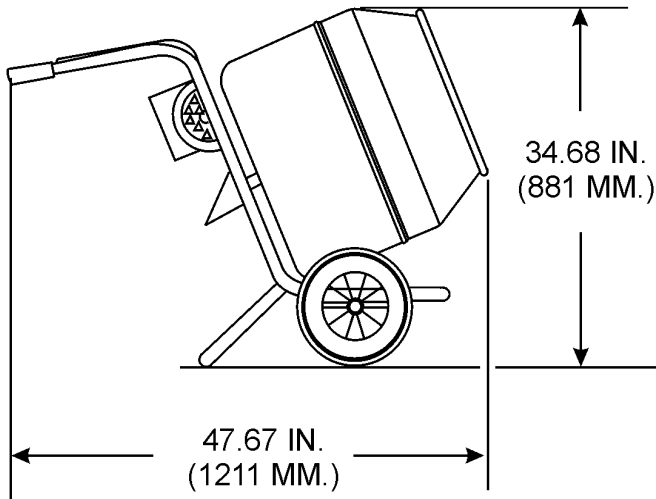
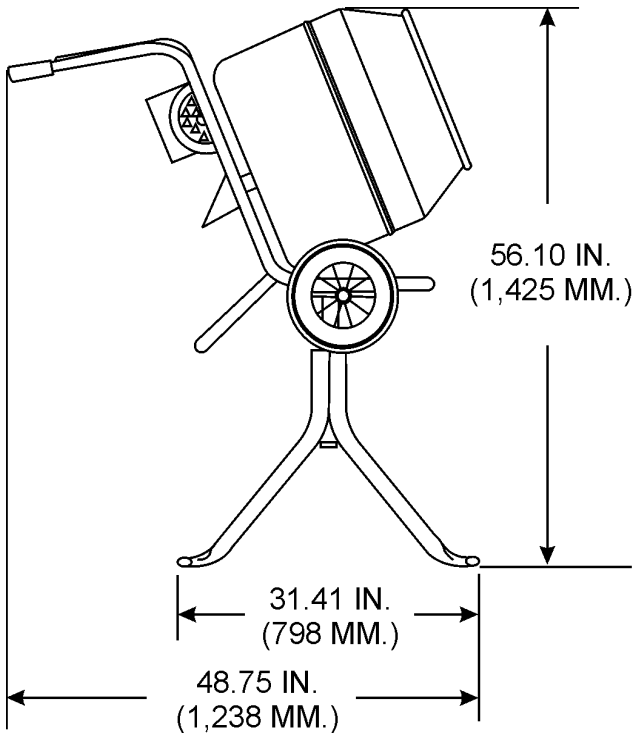

**Figure 1. Mix N' Go
Mixer Dimensions**

STOW PORTO MIXER— DIMENSIONS (ELECTRIC MOTOR)

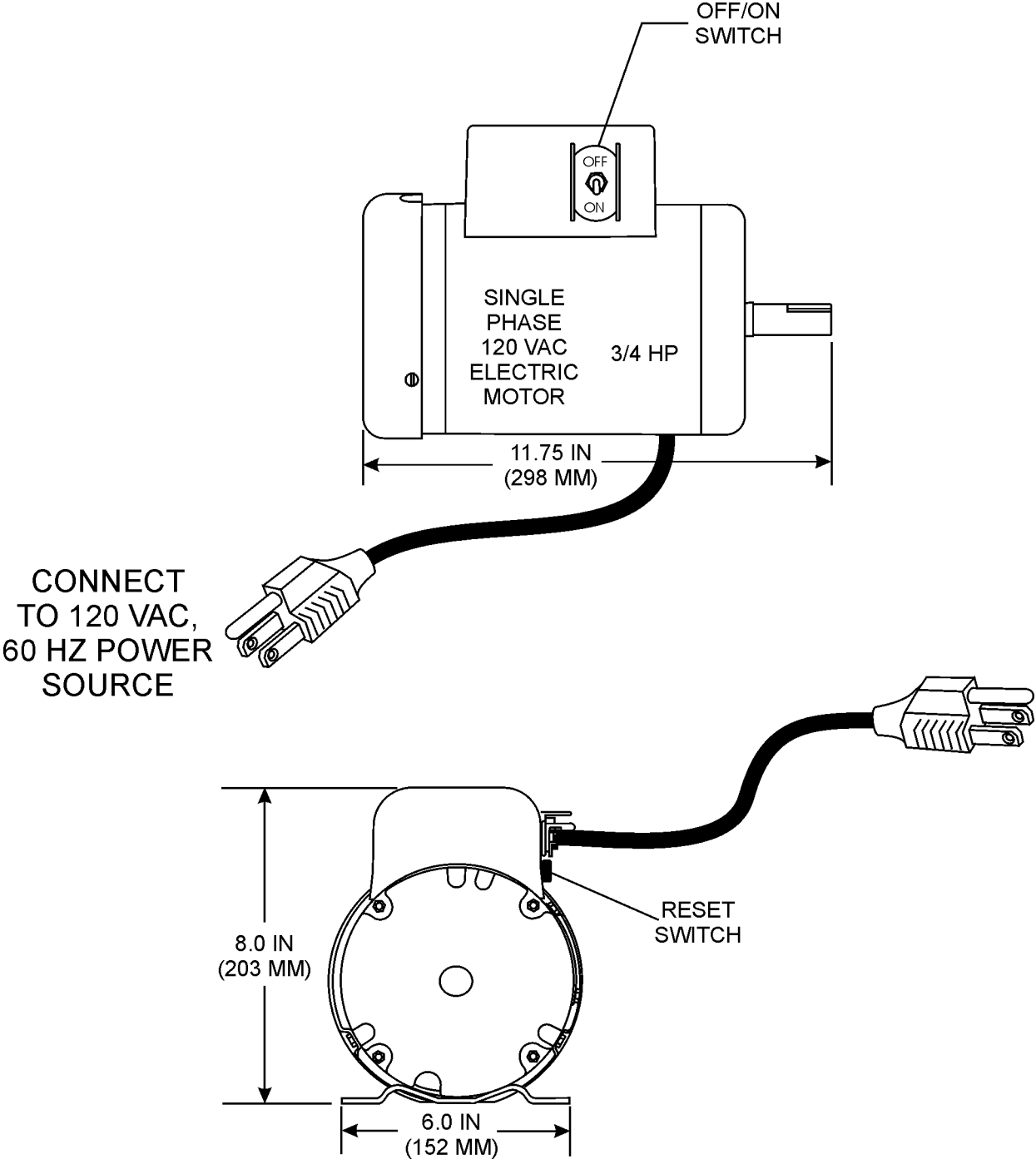

Figure 2. Electric Motor

STOW PORTO MIXER—GENERAL INFORMATION

APPLICATION

This mixer is **only** intended for the production of **concrete** and **mortar**. The mixer must be used for its intended purposes and is not suitable for the mixing of **flammable** or **explosive** substances. The mixer must not be used in an explosive atmosphere.

POWER PLANTS

This portable mixer is powered by either a Briggs and Stratton 4-stroke, vertical valve, single cylinder, gasoline engine rated at 3.5 hp @3,600 rpm. or a 0.75 hp electric motor.

DRUM ASSEMBLY

The drum is instantly removable by unscrewing counter-clockwise. When inserting drum onto gearbox shaft, make sure that drum is fully screwed onto shoulder or threads may be damaged. Use extreme care when screwing on the drum, spinning drum onto the gearbox shaft too fast may damage gearbox.

ELECTRICAL

If mixer is equipped with an **electric motor**, make sure that the power being supplied to the motor corresponds to the voltage rating label on the motor. Supplying the wrong voltage to the electric motor will cause severe electrical damage to the motor.

Always make sure that **OFF/ON** switch on the electric motor is in the **OFF** position before applying power.

It is **strongly recommended** that when plugging in the mixer's power cord into a receptacle, that a G.F.C.I. (**Ground Fault Current Interrupter**) receptacle be used.

EXTENSION CABLES

The extension cable should be a 3-wire configuration that includes a ground wire that conforms to UL code. The wire cross section must be a minimum of 2.5 mm². Choose an extension cord of adequate current carrying as Reference in Table 5. Remember **distance** affects the wire size of the extension cable.

Ensure that the extension cable is carefully laid out avoiding **wet areas**, **sharp edges** and locations where vehicles might run over it. Avoid allowing the extension cable to be trapped underneath the mixer.

Unroll the extension cable fully or it will overheat and could catch fire. Make sure that all extension cable connections are dry and safe. Replace any defective or badly worn extension cable immediately.

PORTABLE GENERATORS

When using a **portable generator** it must have a minimum output of 2.5 kw and be continuous rated.

GEARBOX

The gearbox oil level has been preset at the **factory** prior to shipping. Before inspecting the gearbox oil level (Figures 30 and 31), make sure the gearbox is cold before removing the filler plug. Fill up with **EP90**. or similar gear oil.

TRANSPORTING THE MIXER

Use a ramp (Figure 3) to load and unload the mixer from the transport vehicle. Never drop the mixer onto the ground; damage to the mixer could result.

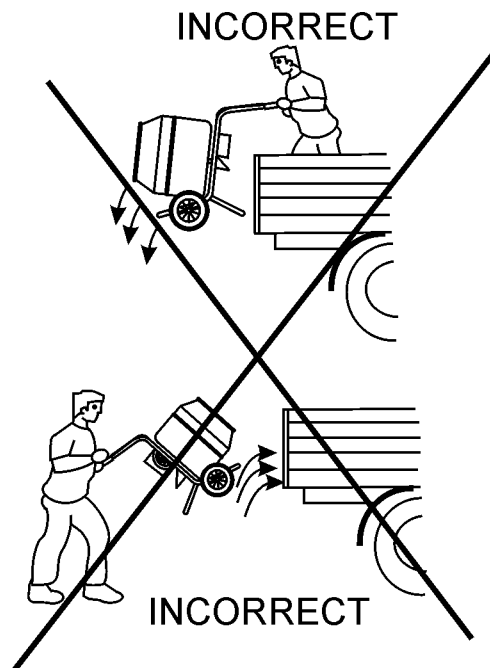
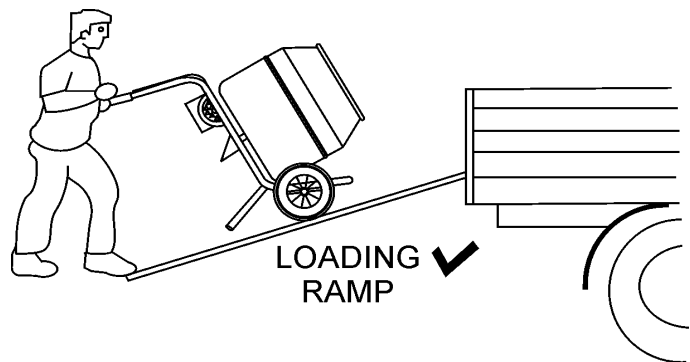

Figure 3. Mixer Loading

STOW PORTO MIXER— MIXER COMPONENTS

Figure 4 shows the basic components of the *STOW Porto Mixer*.

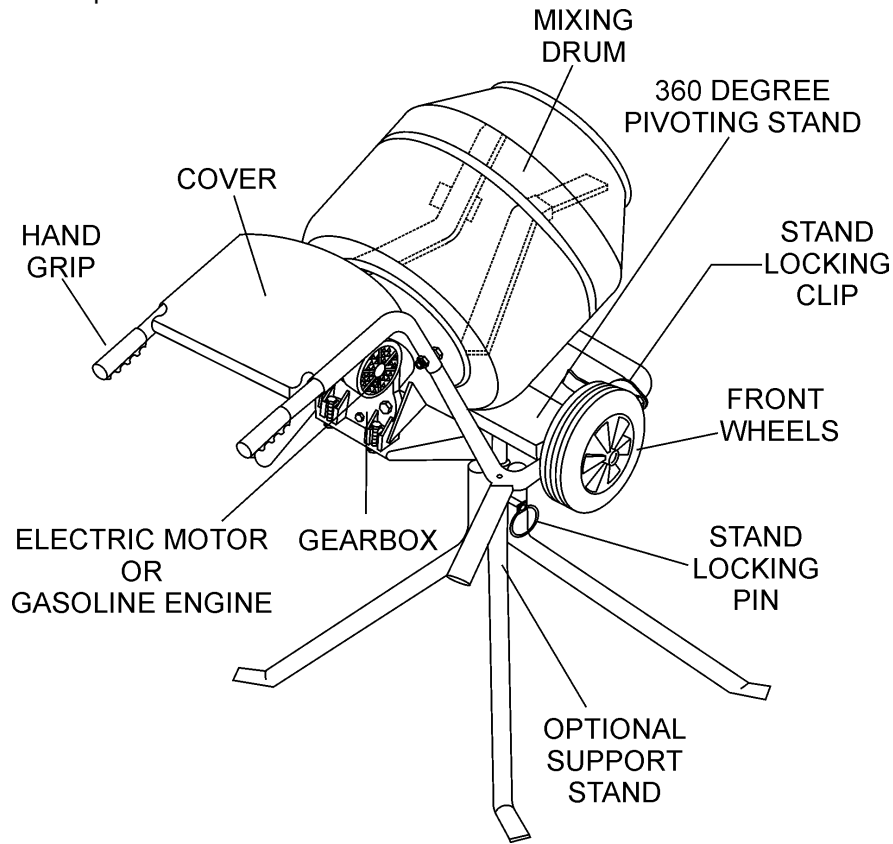

Figure 4. Mixer Components

Table 3. MIXING HINTS

APPLICATIONS	MIX RATIOS	BATCH QUANTITIES					APPROX. BATCH OUTPUT	
		CEMENT 112 lbs. (50 Kgs.) Bag	SAND		STONE			
			CU. FT.	LTR	CU. FT.	LTR	CU. FT.	LTR
Most Ordinary	1:2:4	1/2 BAG	1-1/4	35	2-1/2	71	3	85
Foundations	1:3:6	1/3 BAG	1-1/4	35	2-1/2	71	2-3/4	78
Rough Mass Concrete	1:4:8	1/4 BAG	1-1/4	35	2-1/2	71	2-3/4	78
Watertight Floors, Tanks, Pits, Etc.	1:1-1/2:3	2/3 BAG	1-1/4	35	3	71	3	85

STOW PORTO MIXER— BASIC ENGINE

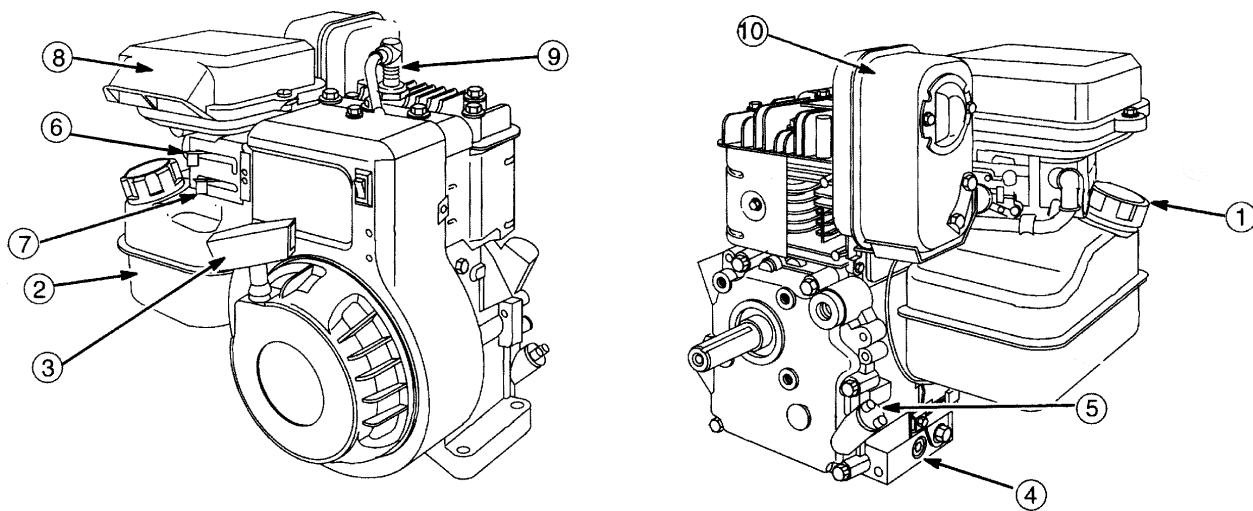

Figure 5. Engine Controls and Components

INITIAL SERVICING

The engine (Figure 5) must be checked for proper lubrication and filled with fuel prior to operation. Refer to the manufacturer's engine manual for instructions and details of operation and servicing. The engine shown above is a **Briggs and Stratton** engine, operation for other types of engines may vary somewhat.

1. **Fuel Filler Cap** – Remove this cap to add unleaded gasoline to the fuel tank. Make sure cap is tightened securely. **DO NOT** over fill.



DANGER

Adding fuel to the tank should be done only when the engine is stopped and has had an opportunity to cool down. In the event of a fuel spill, **DO NOT** attempt to start the engine until the fuel residue has been completely wiped up, and the area surrounding the engine is dry.

2. **Fuel Tank** – Holds unleaded gasoline. For additional information refer to engine owner's manual.
3. **Recoil Starter (pull rope)** – Manual-starting method. Pull the starter grip until resistance is felt, then pull briskly and smoothly.
4. **Oil Drain Plug** – Remove this plug to remove oil from the engine's crankcase.
5. **Dipstick/Oil Filler Cap** – Remove this cap to determine if the engine oil is low. Add oil through this filler port as recommended in Table 4.

6. **Throttle Lever** – Used to adjust engine RPM speed (lever advanced forward **SLOW**, lever back toward operator **FAST**).
7. **Choke Lever** – Used in the starting of a cold engine, or in cold weather conditions. The choke enriches the fuel mixture.

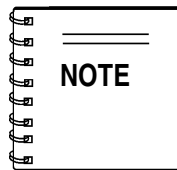

Operating the engine without an air filter, with a damaged air filter, or a filter in need of replacement will allow dirt to enter the engine, causing rapid engine wear.

8. **Air Cleaner** – Prevents dirt and other debris from entering the fuel system. Remove wing-nut on top of air filter canister to gain access to filter element.
9. **Spark Plug** – Provides spark to the ignition system. Set spark plug gap to 0.6 - 0.7 mm (0.024 - 0.028 inch) Clean spark plug once a week.
10. **Muffler** - Used to reduce noise and emissions.

WARNING



Engine components can generate extreme heat. To prevent burns, **DO NOT** touch these areas while the engine is running or immediately after operating. **NEVER** operate the engine with the muffler removed.

STOW PORTO MIXER— ASSEMBLY INSTRUCTIONS

Assembly

1. Remove the mixer drum and associated components from the packing container (Figure 6). Match the components against the parts list to make sure that they are all accounted for.

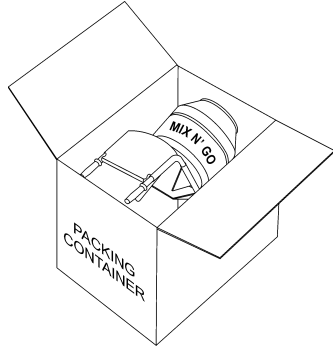

Figure 6. Packing Container

2. Place the mixer frame on a secure level surface, and attach the top cover as shown in Figure 7.

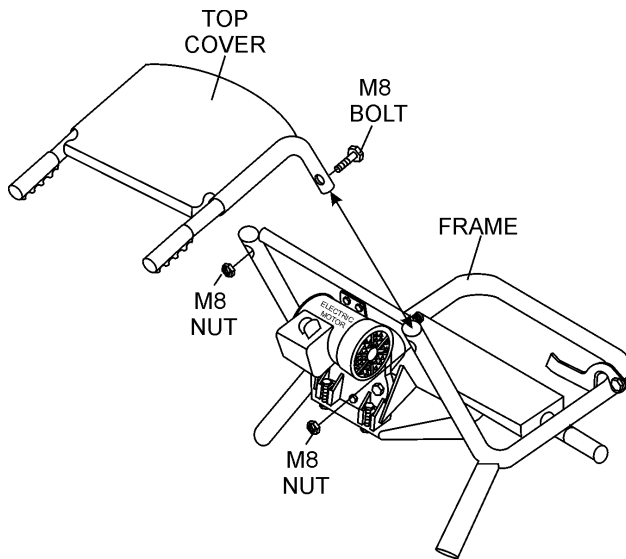

Figure 7. Top Cover Placement

3. Fit the mixing drum onto gearbox shaft as shown in Figure 8. Rotate drum in a clockwise direction, make sure the drum fits right up to the shoulder on the gearbox shaft.

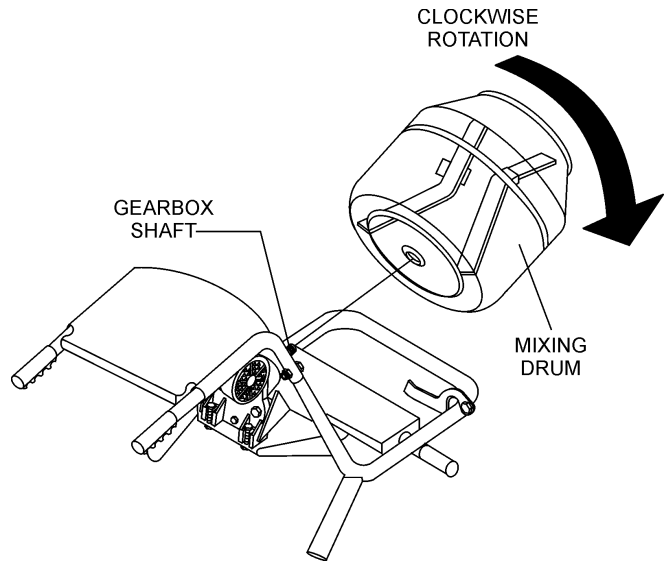

Figure 8. Mixing Drum Placement

4. Place the two halves of the optional support stand together (Figure 9). The left support stand fits into the center boss on the right support stand.
5. Insert the adapter pin through bosses as shown in Figure 9. Once the adapter pin has been inserted and aligned, insert the locking pin. Place the round part of the locking pin over the bottom section of the adapter pin.

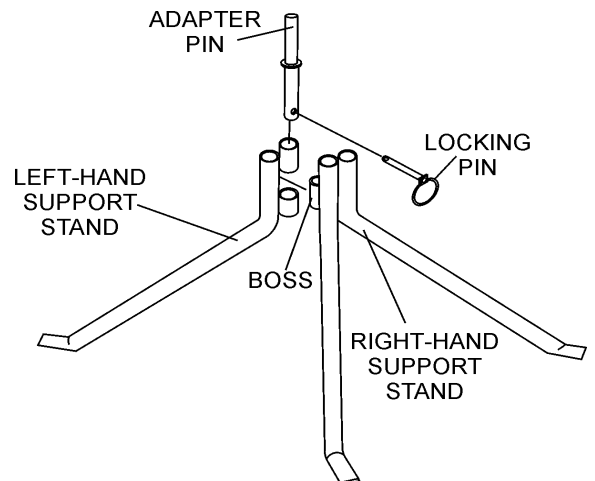

Figure 9. Optional Support Stand

CAUTION



DO NOT *spin* the drum on ***fast***, as this may damage the gearbox.

STOW PORTO MIXER— ASSEMBLY INSTRUCTIONS

6. Tip mixer onto mouth as shown in Figure 10, and insert support stand into frame swivel point.

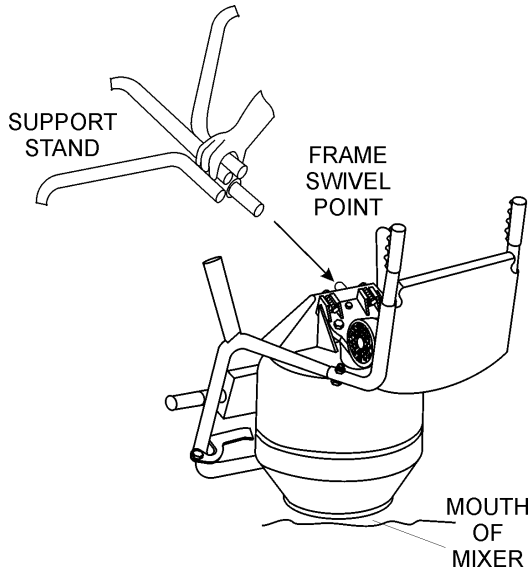

Figure 10. Attaching Support Stand

7. Remove both wheels and wheel retainers from the packing container.
 8. Place one wheel on each side of the mixer's axle as shown in Figure 11. Position washer over axle to secure wheel in place. Insert cotter pin to lock wheel in place.

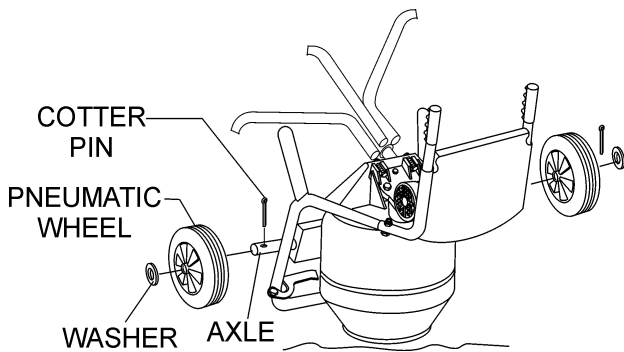

Figure 11. Wheels and Wheel Retainers

9. Before attempting to lift mixer, locate the frame locking clip. Attach the locking clip as shown in Figure 12. This will prevent the mixing drum from moving when the mixer is positioned in an upright position.

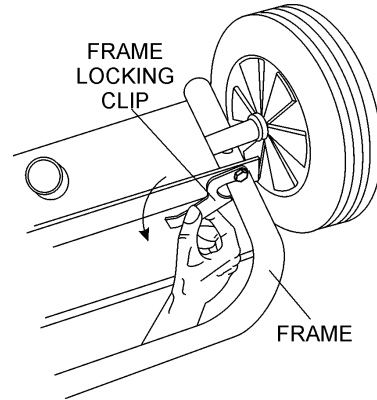

Figure 12. Frame Locking Clip

10. **DO NOT** tilt the mixer on a wet, smooth or slippery surface.



Figure 13. Slippery or Wet Surfaces

11. Once the stand has been assembled, and the locking clip has been secured, begin tilting the mixer to an upright position. Remember **always** tilt from the front of the mixer as shown in Figure 14.

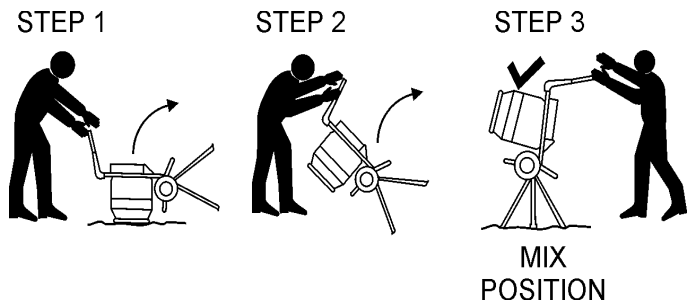

Figure 14. Tilting Mixer to Upright Position

STOW PORTO MIXER— PRE-INSPECTION (GASOLINE ENGINE)

CAUTION



NEVER operate the mixer in a confined area or enclosed area structure that does not provide ample **free flow of air**.



ALWAYS wear approved eye and hearing protection before operating the mixer.

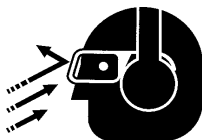

NEVER place hands inside drum while the engine is running. **ALWAYS** shut the engine down before performing any kind of maintenance service on the mixer.



Before Starting

1. Read safety instructions at the beginning of manual.
2. Clean the mixer, removing dirt and dust, particularly the engine cooling air inlet, carburetor and air cleaner.
3. Check the air filter for dirt and dust. If air filter is dirty, replace air filter with a new one as required.
4. Check carburetor for external dirt and dust. Clean with dry compressed air.
5. Check fastening nuts and bolts for tightness.

Engine Oil Check

1. To check the engine oil level, place the mixer on secure level ground with the engine stopped.
2. Remove the filler dipstick from the engine oil filler hole (Figure 15) and wipe clean.

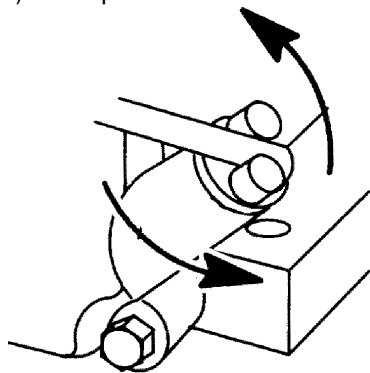

Figure 15. Engine Oil Dipstick (Removal)

3. Insert and remove the dipstick without screwing it into the filler neck. Check the oil level shown on the dipstick.
4. If the oil level is low (Figure 16), fill to the edge of the oil filler hole with the recommended oil type (Table 4). Maximum oil capacity is 0.48 quarts (.45 liters)

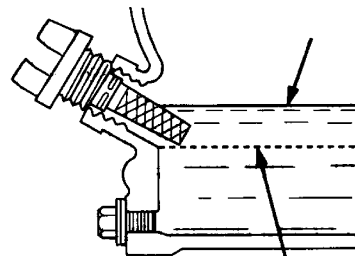

Figure 16. Engine Oil Dipstick (Oil Level)

Table 4. Oil Type

Season	Temperature	Oil Type
Summer	25°C or Higher	SAE 10W-30
Spring/Fall	25°C~10°C	SAE 10W-30/20
Winter	0°C or Lower	SAE 10W-10



Explosive Fuel



Fuel Check

Motor fuels are highly flammable and can be dangerous if mishandled. **DO NOT** smoke while refueling. **DO NOT** attempt to refuel the mixer if the engine is **hot!** or **running**.

1. Remove the gasoline cap located on top of fuel tank.
2. Visually inspect to see if fuel level is low. If fuel is low, replenish with unleaded fuel.
3. When refueling, be sure to use a strainer for filtration. **DO NOT** top-off fuel. Wipe up any spilled fuel.

V-Belt Check

A worn or damaged V-belt can adversely affect the performance of the mixer. If a V-belt is defective or worn simply replace the V-belt as outlined in the maintenance section of this manual.

STOW PORTO MIXER— INITIAL START-UP (ELECTRIC MOTOR)

Initial Start-up Instructions (Electric Motor)

Starting

CAUTION:



DO NOT attempt to operate the mixer until the Safety, General Information and Inspection sections have been read and understood.

1. Before starting, make sure mixer is positioned on a secure flat surface to prevent tipping.
2. Use an extension cord (see Table 5) of adequate current carrying capacity, insert the electric motor's power plug into one end of the extension cord.
3. **NEVER!** use a *worn* or *frayed* extension cord.
4. **NEVER!** operate mixer with V-belt cover removed.

Table 5. Extension Cord Size

No. 12 Wire	No. 10 Wire	No. 8 Wire	No. 6 Wire
50 (feet) (15.24 meters)	75 (feet) (22.86 meters)	100 (feet) (30.48 meters)	200 (feet) (60.96 meters)

DANGER



NEVER! touch the power cord (Figure 17) with *wet hands* or while *standing in water* when it is connected to a power source. The possibly exists of electrical shock (electrocution) even death. **NEVER!** spray water directly on the electric motor.

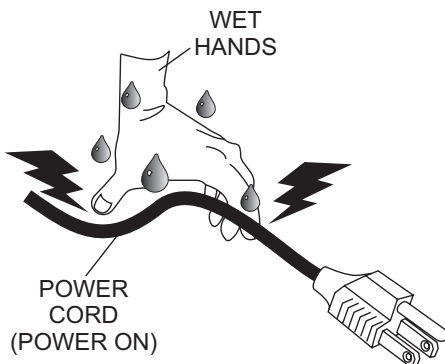

Figure 17. Extension Cord (Wet Hands)

5. Plug the other end of the extension cord into a 120 VAC G.F.C.I. protected receptacle. Remember the power requirements for this electric motor is 120 VAC, 60 Hz. The use of any other input voltage will severely damage the motor.

WARNING:



ALWAYS read the label on the electric motor before applying power. The label will indicate the proper power requirements for the motor. Remember the use of any other input voltage will severely damage the motor.

WARNING:



To prevent tripping (Figure 18) of both the mixer and personnel, position the extension cord so that it lays flat and is not curled underneath the mixer.

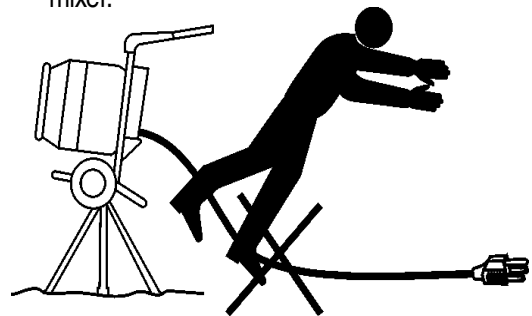

Figure 18. Mixer (Tripping)

6. The drum should be rotating allowing the mixing process to begin. Use a shovel (Figure 19) to place the cement mix inside the drum, add water as required. Be careful to only place the *tip* of the shovel inside the drum. Placing the shovel all the way inside the drum will cause the shovel to strike the blades. This condition will make the shovel rotate, and could cause injury to personnel.

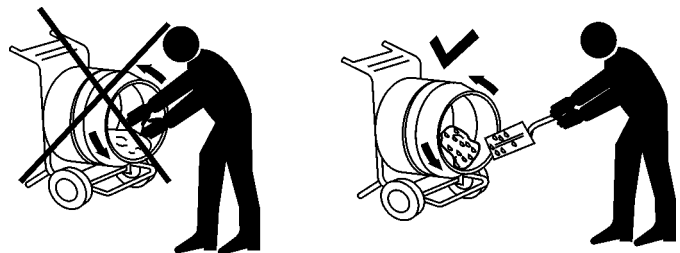

Figure 19. Mixing Drum (Placing Cement Mix)

6. See Table 3 for mixing hints. **NEVER!** place hands inside the drum while the drum is rotating.

STOW PORTO MIXER— INITIAL START-UP (GASOLINE ENGINE)



DO NOT attempt to operate the mixer until the Safety, General Information and Inspection sections of this manual have been read and thoroughly understood.

This section is intended to assist the operator with the initial start-up of the walk-behind trowel. It is extremely important that this section be read carefully before attempting to use the trowel in the field.

Starting the Engine (*BRIGGS & STRATTON*)

1. Place the **choke lever** (Figure 21) in the **CHOKE (CLOSED)** position if starting a **cold** engine.

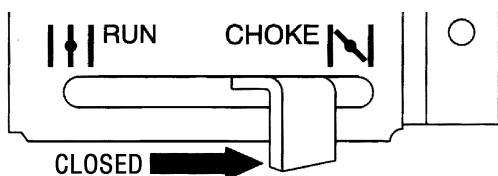

Figure 20. Engine Choke Lever (Closed)

2. Place the **choke lever** (Figure 20) in the **RUN (OPEN)** position if starting a **warm engine** or if the **temperature is warm**.

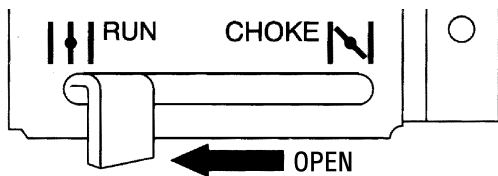

Figure 21. Engine Choke Lever (Open)

3. Place the **throttle lever** (Figure 22) in the **"TURTLE" (IDLE)** position.

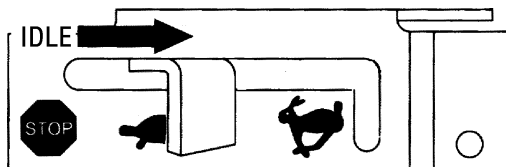

Figure 22. Throttle Lever (Idle Position)

4. Grasp the starter grip (Figure 23) and slowly pull it out. The resistance becomes the hardest at a certain position, corresponding to the compression point. **PULL** the starter grip briskly and smoothly for starting.

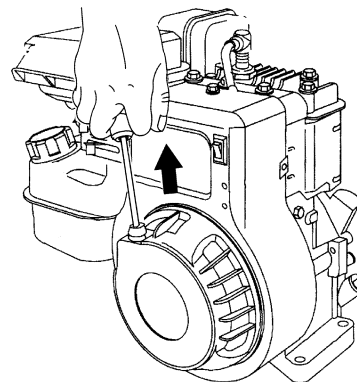

Figure 23. Starter Grip

7. If the engine has started, slowly return the choke lever to the **RUN (OPEN)** position if needed (Figure 24). If the engine has not started repeat steps 1 through 4.

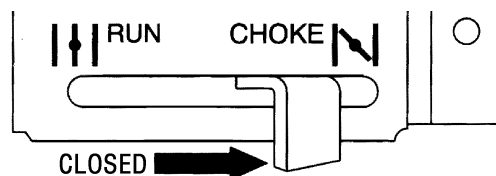

Figure 24. Engine Choke Lever (Closed)

8. Before the mixer is placed into operation, run the engine for several minutes. Check for fuel leaks, and noises that would associate with a loose V-belt cover or component.

9. To begin mixing, place the throttle lever (Figure 25) in the **"RABBIT" (FAST)** position

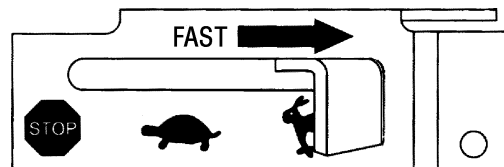

Figure 25. Throttle Lever (Fast Position)

STOW PORTO MIXER— INITIAL START-UP (GASOLINE ENGINE)

Stopping The Engine

Normal Shutdown

1. Move the throttle lever to the **"TURTLE" (IDLE)** position (Figure 26) and run the engine for three minutes at low speed.

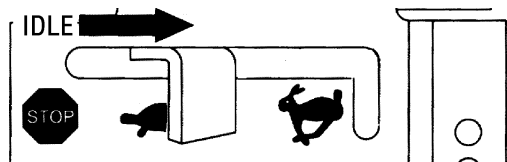

Figure 26. Throttle Lever (Idle Position)

2. After the engine **cools**, move the throttle lever to the **STOP** position (Figure 27).

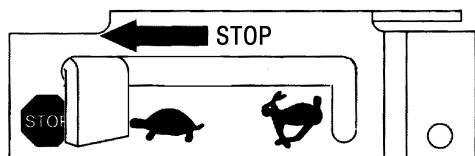

Figure 27. Throttle Lever (Stop Position)

Emergency Showdown

1. Move the throttle lever quickly to the **OFF** position (Figure 28).

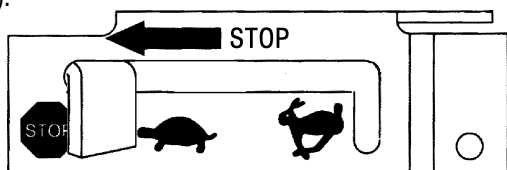

Figure 28. Throttle Lever (Stop Position)

STOW PORTO MIXER— MAINTENANCE

Maintenance

Gearbox Oil Check



1. Position the mixer on a level surface and place a **support block** under the front of the mixer frame as shown in Figure 29. This will level the mixer.
2. **NEVER!** check the gearbox oil level with the mixer tilted up or down. **ALWAYS** check the gearbox oil level with the mixer in a level position.

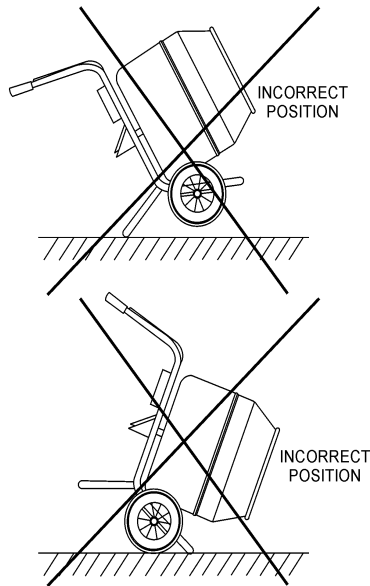
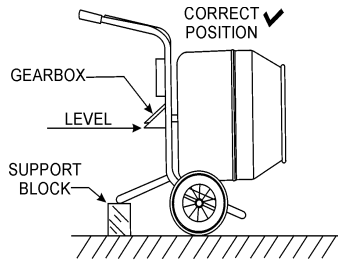

Figure 29. Mixer Positioning (Gearbox Oil Level)

CAUTION :



Check the gearbox oil level **monthly** before operating mixer. Low oil level or no oil will severely damage gearbox.

3. Before inspecting the gearbox oil level, make sure the gearbox is cold before removing the filler plug. Hot! oil can burn skin and cause injury. Let oil **cool** before checking.
4. Remove gearbox oil filler plug (Figure 30) and fill with EP90 or similar gear oil to the level of the filler plug. Replace gearbox oil every 3,000 hours. Gearbox oil capacity is **8-10 ounces**.

5. Insert oil filler plug and tighten.

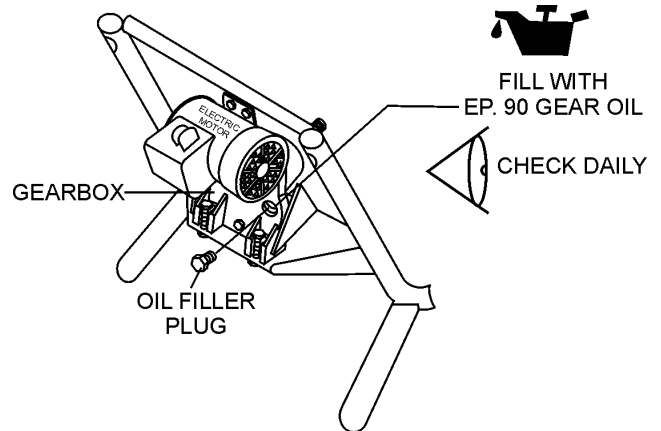

Figure 30. Gearbox Oil Level Check

V-Belt Check

1. To adjust V-belts, remove V-belt cover and loosen the main motor mount bolts (Figure 31), raise electric motor and retighten bolts. Belt tension should be adjusted so that the maximum deflection is approximately 3/8 inch (10 mm).
2. Replace V-belt cover.

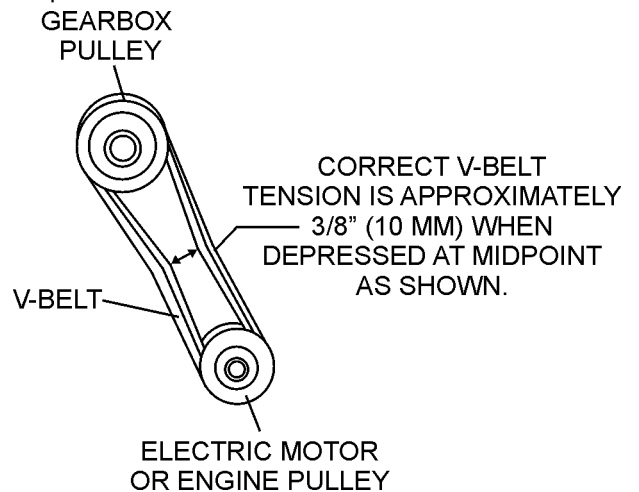

Figure 31. V-belt Adjustment

Gearbox Removal

1. Remove drum by turning counter-clockwise to release from gearbox shaft.
2. Remove pulley, remember the nut securing the pulley is left-hand threaded. Remove circlip, and draw out shaft.
3. Remove the 5 bolts securing rear plate.
4. Reassemble in reverse order, taking care to ensure gear teeth are meshed correctly.

STOW PORTO MIXER— MAINTENANCE (GASOLINE ENGINE)

Table 6. Engine Maintenance Schedule

DESCRIPTION (3)	OPERATION	BEFORE	FIRST MONTH OR 10 HRS.	EVERY 3 MONTHS OR 25 HRS.	EVERY 6 MONTHS OR 50 HRS.	EVERY YEAR OR 100 HRS.	EVERY 2 YEARS OR 200 HRS.
Engine Oil	CHECK	X					
	CHANGE		X				
Air Cleaner	CHECK	X					
	CHANGE			X (1)			
All Nuts & Bolts	Re-tighten If Necessary	X					
Spark Plug	CHECK-CLEAN				X		
	REPLACE						X
Cooling Fins	CHECK				X		
Spark Arrester	CLEAN					X	
Fuel Tank	CLEAN					X	
Fuel Filter	CHECK					X	
Idle Speed	CHECK-ADJUST					X (2)	
Valve Clearance	CHECK-ADJUST						X (2)
Fuel lines	CHECK	Every 2 years (replace if necessary) (2)					

(1) Service more frequently when used in **DUSTY** areas.

(2) These items should be serviced by your service dealer, unless you have the proper tools and are mechanically proficient. Refer to the BRIGGS AND STRATTON Shop Manual for service procedures

(3) For commercial use, log hours of operation to determine proper maintenance intervals.

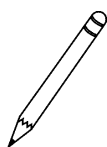
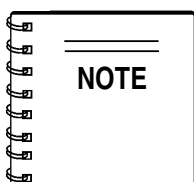

Reference manufacturer engine manual for specific servicing instructions.

STOW PORTO MIXER— MAINTENANCE (GASOLINE ENGINE)

Maintenance

Perform the scheduled maintenance procedures as defined by Table 6 and below:

DAILY

- Thoroughly remove dirt and oil from the engine and control area. Clean or replace the air cleaner elements as necessary. Check and retighten all fasteners as necessary. Check the gearbox for oil leaks. Repair or replace as needed.

WEEKLY

- Remove the fuel filter cap and clean the inside of the fuel tank.
- Remove or clean the filter at the bottom of the tank.
- Remove and clean the spark plug (Figure 32), then adjust the spark gap to 0.024 ~0.028 inch (0.6~0.7 mm). This unit has electronic ignition, which requires no adjustments.

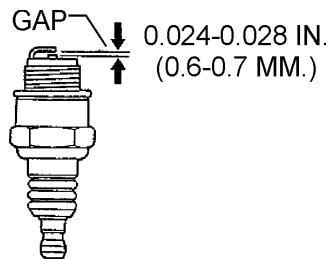

Figure 32. Spark Plug Gap

ENGINE OIL

- Drain the engine oil when the oil is **warm** as shown in Figure 33.
- Remove the oil drain bolt and sealing washer and allow the oil to drain into a suitable container.
- Replace engine oil with recommended type oil as listed in Table 4. Engine oil capacity is .48 quarts (0.45 liters). **DO NOT** overfill.
- Install drain bolt with sealing washer and tighten securely.

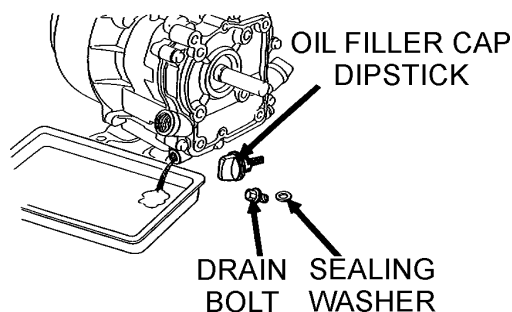

Figure 33. Engine Oil (Draining)

DANGER :



DO NOT use gasoline as a cleaning solvent, because that would create a risk of fire or explosion.

ENGINE AIR CLEANER

- Remove the air cleaner cover and foam filter element as shown in Figure 34.
- Clean foam element in warm, soapy water or nonflammable solvent. Rinse and dry thoroughly. Dip the element in clean engine oil and completely squeeze out the excess oil from the element before installing.

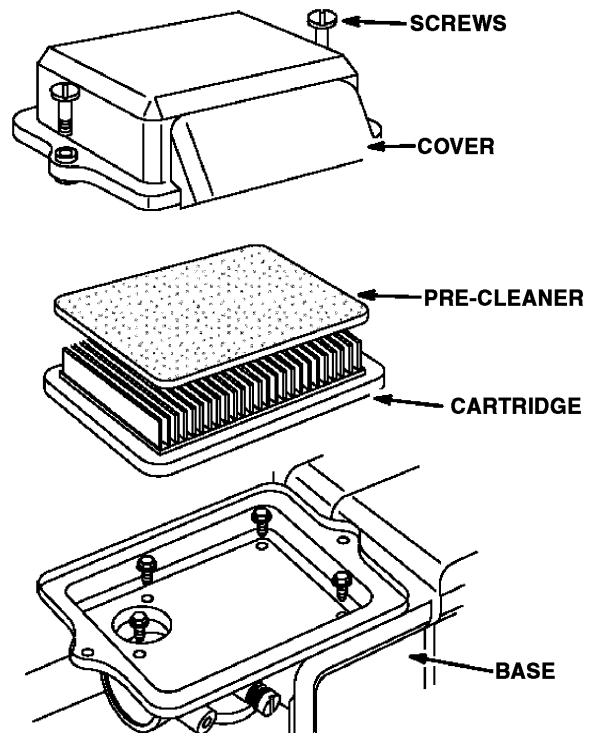

Figure 34. Engine Air Cleaner

STOW PORTO MIXER— PREPARATION FOR LONG -TERM STORAGE

Mixer Storage

For storage of the mixer for over 30 days, the following is recommended:

- Drain the fuel tank completely, or add STA-BIL to the fuel.
- Run the engine until the fuel is completely consumed.
- Completely drain used oil from the engine crankcase and fill with fresh clean oil, then follow the procedures described in the engine manual for engine storage.
- Clean the entire mixer and engine compartment.
- Cover the mixer and place it a clean dry area, that is protected from harsh elements.

STOW PORTO MIXER— TROUBLESHOOTING (ENGINE)

TABLE 7. ENGINE TROUBLESHOOTING

SYMPTOM	POSSIBLE PROBLEM	SOLUTION
Difficult to start		
Fuel is available but spark plug will not ignite. (Power available at high tension cable).	Ignition plug being bridge?	Check ignition system.
	Carbon deposit at ignition?	Clean or replace ignition.
	Short circuit due to defective insulators?	Replace insulators.
	Improper spark gap?	Set spark plug gap to the correct gap.
Fuel is available but spark plug will not ignite. (Power NOT available at high tension cable).	Short circuit at stop switch?	Check stop switch circuit. Replace stop switch if defective.
	Ignition coil defective?	Replace ignition coil.
Fuel is available and spark plug ignites (compression normal).	Muffler clogged with carbon deposits?	Clean or replace muffler.
	Fuel in use inadequate (water, dust)?	Flush fuel sytem and replace with fresh fuel.
	Air Cleaner clogged?	Clean or replace air cleaner.
Fuel is available and spark plug ignites (compression low).	Defective cylinder head gasket?	Tighten cylinder head bolts or replace head gasket.
	Cylinder worn?	Replace cylinder.
	Spark plug loose?	Tighen spark plug.
Operation not satisfactory		
Not enough power available (compression normal, no miss-firing).	Air cleaner clogged?	
	Air in fuel line?	Bleed (remove air) from fuel line.
	Fuel level in carbureator float chamber improper?	Adjust carbureator float
	Carbon deposits in cylinder?	Clean or replace cylinder
Not enough power available (compression normal, miss-firing).	Ignition coil defective?	Flush fuel sytem and replace with fresh fuel.
	Ignition plug often shorts?	Replace ignition wires, clean ignition.
	Fuel in use inadequate (water, dust)?	Flush fuel sytem and replace with fresh fuel.
Engine overheats.	Excessive carbon depostion in combustion chamber?	Clean or replace crankcase.
	Exhaust or muffler clogged with carbon.	Clean or replace muffler.
	Spark plug heat value incorrect?	Replace spark plug with correct type spark plug.

STOW PORTO MIXER— TROUBLESHOOTING (ENGINE/MIXER)

TABLE 7. ENGINE TROUBLESHOOTING (Continued)

SYMPTOM	POSSIBLE PROBLEM	SOLUTION
Operation not satisfactory		
Rotational speed fluctuates.	Governor adjustment improper?	Adjust governor to correct lever.
	Governor spring defective?	Clean or replace ignition.
	Fuel flow erratic?	Check fuel line.
	Air taken in through suction line?	Check suction line.
Recoil starter not working properly.	Dust in rotating part?	Clean recoil starter assembly.
	Spring spring failure?	Replace sprial spring.

TABLE 8. MIXER TROUBLESHOOTING

SYMPTOM	POSSIBLE PROBLEM	SOLUTION
Drum rotates rough.	Defective gearbox?	Check that the gears and bearings are not worn . Replace as necessary.
	Worn V-belt?	Replace V-belt.
	Loose pulley?	Tighten or replace pulley.
Drum does not rotate at all.	Incorrect or no voltage being supplied to electric motor?	Check that the electric motor has the correct supply voltage.
	Power to electric motor?	Inspect power source and extension cord. Push reset button on electric motor.
	Fuel?	Check level of fuel in fuel tank. Add fuel if necessary. Make sure fuel is being supplied to the engine. Check to ensure that the fuel filter is not clogged.
	Broken V-belt?	Replace V-belt.
	Defective gearbox?	Check that the gears and bearings are not broken. Replace as necessary.
	Defective motor?	Replace motor.

STOW PORTO MIXER— EXPLANATION OF CODE IN REMARKS COLUMN

How to read the marks and remarks used in this parts book.

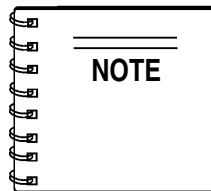

The contents of this parts catalog are subject to change without notice.

Items Found In the “Remarks” Column

Serial Numbers-Where indicated, this indicates a serial number range (inclusive) where a particular part is used.

Model Number-Where indicated, this shows that the corresponding part is utilized only with this specific model number or model number variant.

Items Found In the “Items Number” Column

All parts with same symbol in the number column, *, #, +, %, or ■, belong to the same assembly or kit.

Note: If more than one of the same reference number is listed, the last one listed indicates newest (or latest) part available.

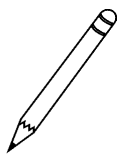
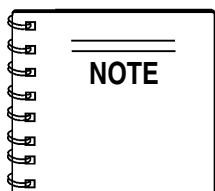

If more than one of the same reference number is listed, the last one listed indicates newest (or latest) part available.

STOW PORTO MIXER — SUGGESTED SPARE PARTS

STOW PORTO MIXER 1 TO 3 UNITS

1 to 3 Units

Qty.	P/N	Description
2	DM1840	V-BELT, A23 (ELECTRIC MOTOR)
2	MS-01	V-BELT, A24 (GASOLINE)

STOW PORTO MIXER — NAME PLATE AND DECALS

NAME PLATE AND DECALS

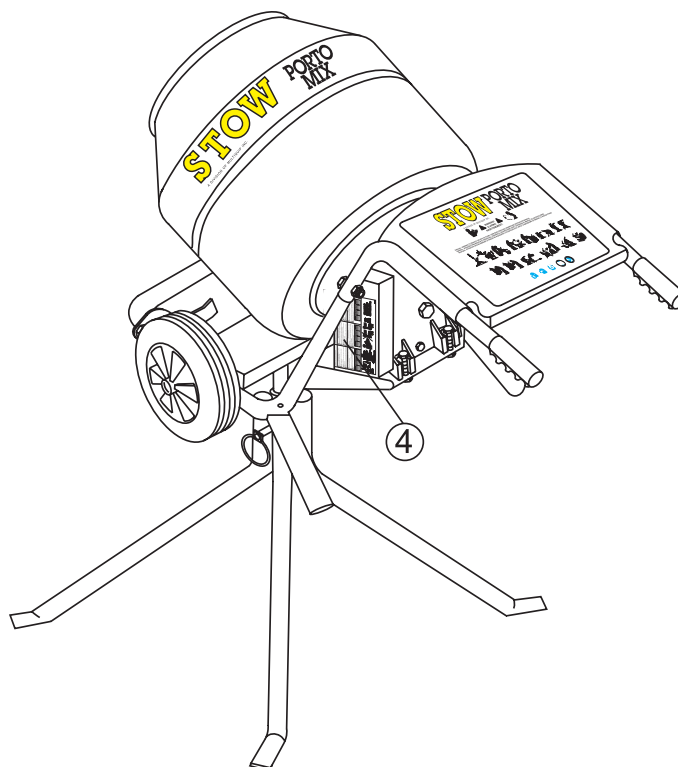
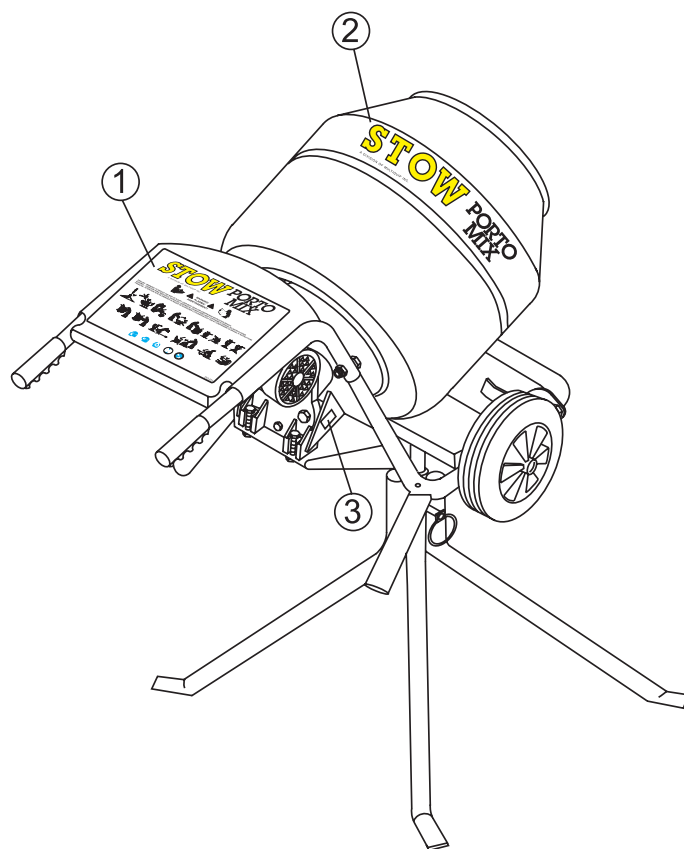

STOW PORTO MIXER — NAME PLATE AND DECALS

NAME PLATE AND DECALS

NAMEPLATE AND DECALS.

<u>NO</u>	<u>PART NO</u>	<u>PART NAME</u>	<u>QTY.</u>	<u>REMARKS</u>
1	DCL300	DECAL: WARNING STOW	1	
2		DECAL: STOW PORTO MIX	1	INCLUDED WITH TUB
3		DECAL: NAMEPLATE	1	CONTACT MQ PARTS DEPT.
4	DCL250	DECAL: WARNING MAINTENANCE	1	

SEE DECAL ILLUSTRATIONS ON PAGES 11 AND 12.

STOW PORTO MIXER — MIXER ASSY. (PLASTIC DRUM)

MIXER ASSY. (PLASTIC DRUM)

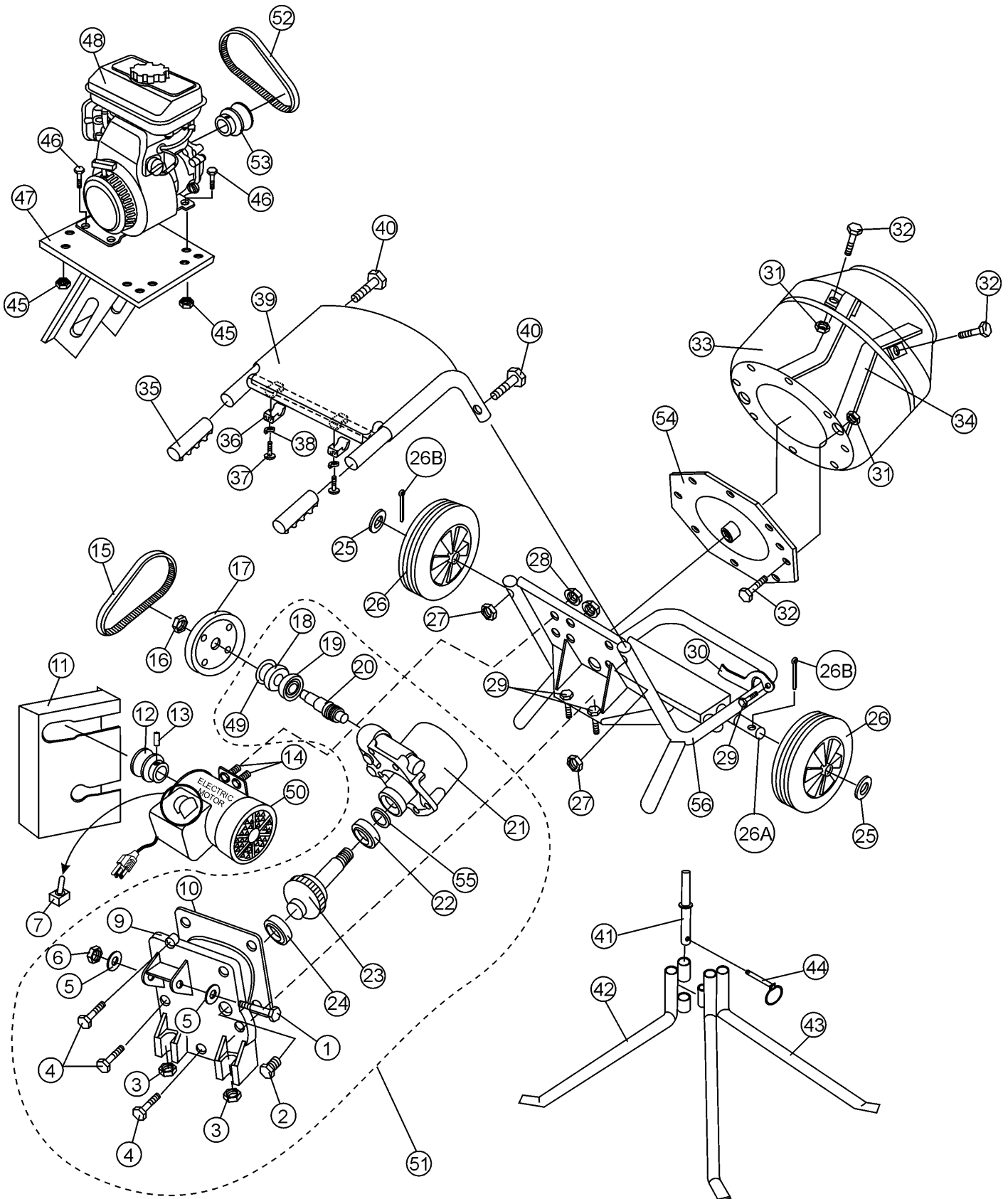

STOW PORTO MIXER — MIXER ASSY. (PLASTIC DRUM)

MIXER ASSY. (PLASTIC DRUM)

<u>NO.</u>	<u>PART NO.</u>	<u>PART NAME</u>	<u>QTY.</u>	<u>REMARKS</u>
1#	DM3150	HEX HEAD BOLT M12 x 70	1	
2#	DM1356	OIL FILLER PLUG M14 x 2 x 15L	1	
3#	DM1912	HEX NUT M10	2	
4#	DM355	HEX HEAD BOLT M8 x P1.25 x 24L	3	
5#	DM3151	FLAT WASHER M12	2	
6#	DM3152	HEX NUT M12	1	
7	SP9012	TOGGLE SWITCH	1	
9#	DM1320	GEAR BOX BACK COVER	1	
10#	DM1357	GEAR BOX SEAL		
11	DM1380	BELT GUARD	1	
12	DM1821	DRIVE PULLEY	1	ELECTRIC MOTOR ONLY
13	DM1822	SET SCREW M6 x 12L	1	
14	DM2020	BOLT M6 x 18	2	
15	DM1840	V-BELT, A23	1	ELECTRIC MOTOR ONLY
16	DM1332	NUT M12	1	
17	DM1810	GEARBOX PULLEY	1	
18#	DM1353	OIL SEAL 20 x 42.5 x 10	1	
19#	DM1352	BEARING RACE 6004	1	
20#	DM1331	WORM GEAR	1	
21#	DM1310	GEARBOX CASE	1	
22#	DM1351	BEARING RACE 6006	1	
23#	DM1333	GEAR & SHAFT	1	
24	DM1351	BEARING RACE 6006	1	
25	DM1741	WASHER	2	
26	DM1730	WHEEL, PNEUMATIC	2	
26A	DM1740	AXLE	1	
26B	DM1742	COTTER PIN	2	
27	DM1641	HEX NUT M8	2	
28	DM2021	NUT	2	
29	DM1911	HEX HEAD BOLT M10 x P1.5 x 40L	3	
30	DM1141	DRUM LOCK	1	

STOW PORTO MIXER — MIXER ASSY. (PLASTIC DRUM)

MIXER ASSY. (PLASTIC DRUM)

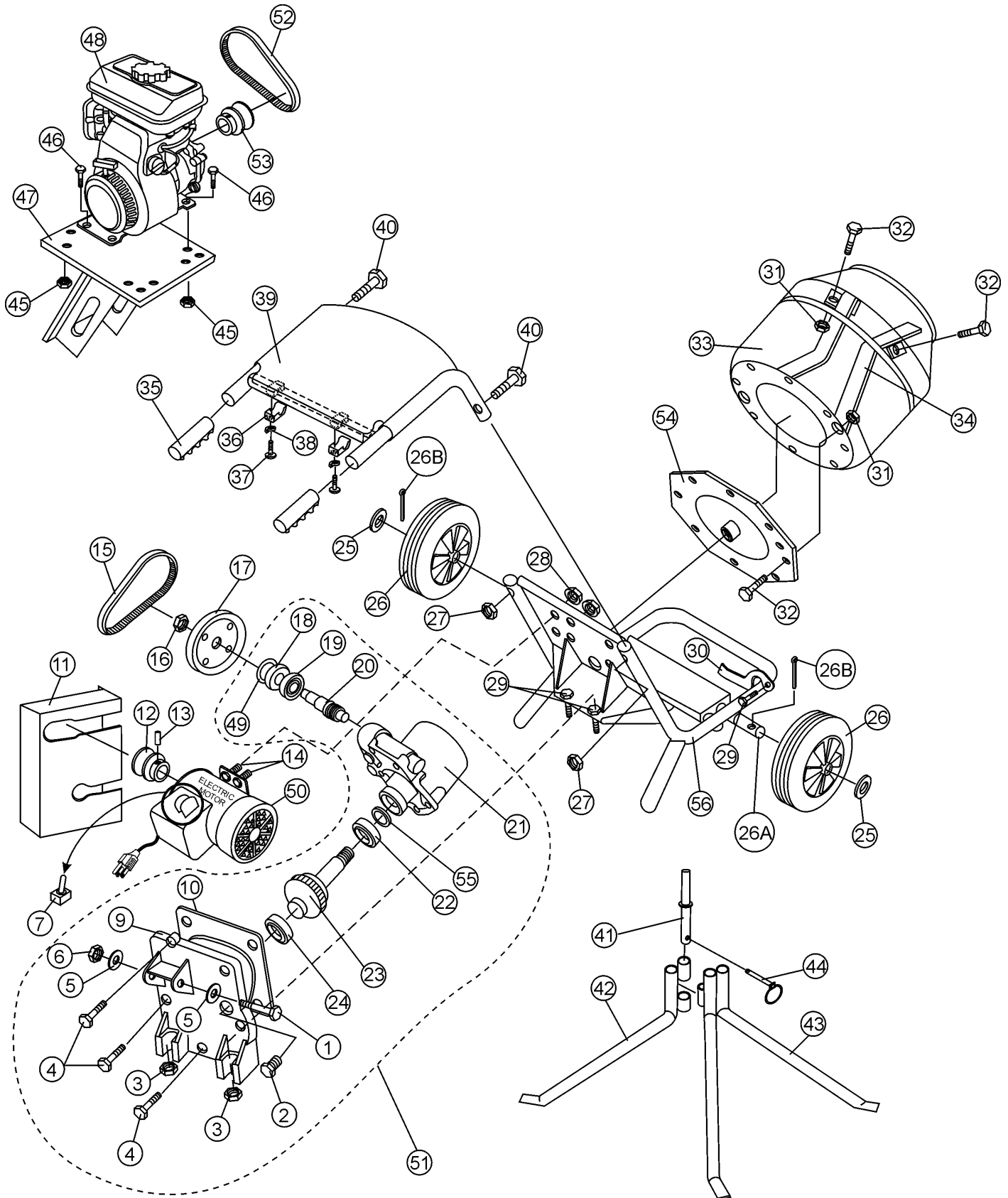

STOW PORTO MIXER — MIXER ASSY. (PLASTIC DRUM)

MIXER ASSY. (PLASTIC DRUM)

<u>NO.</u>	<u>PART NO.</u>	<u>PART NAME</u>	<u>QTY.</u>	<u>REMARKS</u>
31	DM1527	HEX NUT M10	12	
32	DM1524	BOLT	12	
33	DM1510	PLASTIC BARREL	1	
34	DM1531	BLADE, BARREL	2	
35	DM1613	HANDLE GRIP, RUBBER	2	
36	DM1630	TOP COVER CLAMP	2	
37	DM1631	SCREW 5.5 x 25	2	
38	DM1632	LOCK WASHER	2	
39	DM1620	TOP COVER, PLASTIC	1	
40	DM1640	BOLT M8 SPECIAL DOME HEAD	2	
41	DM1221	STAND, ADAPTER	1	
42	DM1212	STAND, BOTTOM LH (2 BOSS)	1	
43	DM1213	STAND, BOTTOM RH (1 BOSS)	1	
44	DM1231	CLIP LINCH PIN	1	
45	DM3050	NUT M8BOLT M8 x 35	4	
46	DM3051	BOLT M8 x 35	4	
47	DM3000	ENGINE MOUNT (GASOLINE)	1	
48	912321040E1	ENGINE, 3.5 HP BRIGGS & STRATTON	1	
49#	DM1358	RETAINER RING	1	
50	34579	MOTOR, ELECTRIC 3/4 H.P.	1	
51	DM1300	GEARBOX ASSEMBLY	1	INCLUDES ITEMS/#
52	MS01	V-BELT, A24	1	GASOLINE ENGINE ONLY
53	EM901006	DRIVE PULLEY	1	GASOLINE ENGINE ONLY
54	DM1521	MOUNTING PLATE	1	
55	DM1354	SEAL, OIL	1	
56	DM1105	MAIN FRAME	1	



A DIVISION OF MULTIQUIP INC.

Terms and Conditions of Sale STOW Construction Equipment

PAYMENT TERMS

Terms of payment for unit sales are 2% 15 days net 30 days from date of invoice unless otherwise specifically stated on our invoice. Parts invoices have terms of net 10 days.

Minimum parts billing is \$15.00 net.

Applicable discounts will be computed on merchandise value only. Late charges will be assessed at prevailing rates. Cash discounts cannot be taken on current billings if any previously billed amounts are past due.

FREIGHT POLICY

Freight policy is established to offer customers every advantage possible. Due to bulk freight ratings on some equipment and other shipping considerations, freight policies differ by equipment type. Actual back freight may be charged for shipments originating from other than specified FOB warehouses. **See Freight Policy for details.**

All STOW domestic sales are FOB nearest available designated MQ/STOW warehouse. Export orders are ex-works factory located in Carson, CA or Boise, ID.

Additions to orders already shipped cannot be accepted for freight minimums.

Should STOW elect to make partial shipments of an order originally complying with the "freight allowed" requirements, transportation charges will be absorbed by STOW on any subsequent shipment applying to that order.

All other orders will be shipped collect or prepaid with charges added to the invoice. STOW's responsibility ceases when a signed manifest has been obtained from the carrier, and any claim for shortage or damage must be settled between the consignee and the carrier.

Parts: FOB Carson, California or Boise, Idaho. **See Freight Policy for details and additional discounts.**

DROP SHIPMENTS

STOW reserves the right to refuse Drop Shipments outside the normal service area of the purchasing dealer.

FIELD WAREHOUSES

Field Warehouses are currently located in California, Georgia, Idaho, Iowa, and New Jersey

SPECIAL EXPEDITING SERVICE

The higher of a \$35.00 surcharge or actual costs will be added to the invoice for special handling, including bus shipments, or in cases where STOW personnel must personally deliver the equipment or parts to the carrier.

RETURNED GOODS POLICY

Return shipments may be accepted and credit allowed, subject to the following provisions.

1. A Returned Material Authorization (RMA) must be approved by STOW prior to shipment. Approvals for returned goods must be with just cause and are at the sole discretion of STOW. A copy of the Authorization must accompany the shipment to the designated Warehouse.
2. Parts being returned must be listed as currently supplied on the current parts list.
3. Parts must be in new and resalable condition in the original package, with part numbers clearly marked.
4. Units and accessories must be current models in the latest price list and in new and resalable condition.
5. Special order items are not returnable for credit.
6. Credit on returned parts and units will be issued at actual dealer net price at time of purchase less 15% restocking charge.
7. All returned shipments are to be made to the STOW designated receiving point, freight prepaid at the sender's expense.

The sender will be notified of any material received that does not meet the above provisions. Such material will be held for 30 days from notification pending instructions. If a reply is not received within 30 days, the material will be returned to the sender at his expense with no credit issued.

PRICING, REBATES AND SPECIFICATIONS

Every effort will be made to provide adequate notice of changes; however, prices and equipment specifications are subject to change without notice.

Price changes are effective on a specific date and all orders received on or after that date will be billed at the revised price.

Rebates for price reductions and added charges for price increases will not be made for stock in dealer inventory at the time of a price change.

STOW reserves the right to quote and sell direct to Government agencies and to Original Equipment Manufacturer accounts who use our products as integral parts of their own products.

LIMITATION OF SELLER'S LIABILITY

STOW shall not be liable hereunder for damages in excess of the purchase price of the item with respect to which damages are claimed and in no event shall STOW be liable for loss of profit or good will or for any other special, consequential or incidental damages.

LIMITATION OF WARRANTIES

There are no warranties, express or implied, made by STOW hereunder on Products manufactured or distributed by it except the warranty against defects in material and workmanship on new Products to the original purchaser, as set forth in the STOW New Product Limited Warranty.



A DIVISION OF MULTIQUIP INC.

Atlanta • Boise • Newark • Quebec, Canada
Manchester, UK • Rio de Janeiro, BR • Puebla, MX

STOW CONSTRUCTION EQUIPMENT

POST OFFICE BOX 6254
CARSON, CALIFORNIA 90749
310-661-4242 • 877-BUY-STOW
FAX: 310-604-9237
E-MAIL: stow@stowmfg.com
www.stowmfg.com

PARTS AND OPERATION MANUAL

HERE'S HOW TO GET HELP

*PLEASE HAVE THE MODEL AND SERIAL NUMBER
ON-HAND WHEN CALLING*

PARTS DEPARTMENT

800-427-1244 or 310-537-3700

FAX: 800-672-7877 or 310-637-3284

SERVICE DEPARTMENT

800-478-1244

FAX: 310- 537-4259

TECHNICAL ASSISTANCE

800-478-1244

FAX: 310- 631-5032

WARRANTY DEPARTMENT

888-661-4279, or 310-661-4279

FAX: 310- 537-1173

STOW
A DIVISION OF MULTIQUIP INC.

STOW CONSTRUCTION EQUIPMENT

A DIVISION OF MULTIQUIP INC.

POST OFFICE BOX 6254

CARSON, CA 90749

310-537-3700 • 888-252-STOW [888-252-7869]

FAX: 310-537-1986 • FAX: 800-556-1986

E-MAIL: stow@multiquip.com • WWW: stowmfg.com

PARTS DEPARTMENT:

800-427-1244

FAX: 800-672-7877

SERVICE DEPARTMENT/TECHNICAL ASSISTANCE:

800-478-1244

FAX: 310-631-5032