

Operating Instructions

Conveyor Hopper SSK 5-DURO

Sterling Material Processing
5200 West Clinton Ave.

Milwaukee, WI 53223

Telephone: (414) 354-0970

Fax: (414) 354-6421

www.sterlco.com

Technical service:

Service department

Telephone: (800) 423-3183

Edition: 10/01

These operating instructions are for:*

(* Please fill in personally)

Serial number: _____

Built in: _____

Date of delivery: _____

Number of delivery: _____

Date of commissioning: _____

Location: _____

Group of machines: _____

Sterling Material Processing retains all rights to change the information in these operating instructions at any time without notice.

We assume no liability for any errors or direct or indirect damage resulting in context with these operating instructions.

Copying, translation or publication in any form except for personal use of purchaser requires approval from Sterling Material Processing.

All rights reserved.

Please note that our address and phone information has changed. Please reference this page for updated contact information.



These manuals are obsolete and are provided only for their technical information, data and capacities. Portions of these manuals detailing procedures or precautions in the operation, inspection, maintenance and repair of the products may be inadequate, inaccurate, and/or incomplete and shouldn't be relied upon. Please contact the ACS Group for more current information about these manuals and their warnings and precautions.

Parts and Service Department

The ACS Customer Service Group will provide your company with genuine OEM quality parts manufactured to engineering design specifications, which will maximize your equipment's performance and efficiency. To assist in expediting your phone or fax order, please have the model and serial number of your unit when you contact us. A customer replacement parts list is included in this manual for your convenience. ACS welcomes inquiries on all your parts needs and is dedicated to providing excellent customer service.

For immediate assistance, please contact:

- North, Central and South America, 8am – 5pm CST +1 (800) 483-3919 for drying, conveying, heating and cooling and automation. For size reduction: +1 (800) 229-2919.
North America, emergencies after 5pm CST (847) 439-5855
North America email: acsuscanadacustserv@corpemail.com
- Mexico, Central & South America
Email: acslatinamericacustserv@corpemail.com
- Europe, Middle East & Africa +48 22 390 9720
Email: acseuropecustserv@corpemail.com
- India +91 21 35329112
Email: acsindiacustserv@corpemail.com
- Asia/Australia +86 512 8717 1919
Email: acsasiacustserv@corpemail.com

Sales and Contracting Department

Our products are sold by a worldwide network of independent sales representatives. Contact our Sales Department for the name of the sales representative nearest you.

Let us install your system. The Contract Department offers any or all of these services: project planning; system packages including drawings; equipment, labor, and construction materials; and union or non-union installations.

For assistance with your sales or system contracting needs please Call:

North, Central and South America +1 (262) 641-8600 or +1 (847) 273-7700 Monday–Friday, 8am–5pm CST

Europe/Middle East/Africa +48 22 390 9720

India +91 21 35329112

Asia/Australia +86 512 8717 1919

Facilities:

ACS offers facilities around the world to service you no matter where you are located. For more information, please visit us at www.acscorporate.com

United States:

ACS Schaumburg – Corporate Offices

1100 E. Woodfield Road
Suite 588
Schaumburg, IL 60173
Phone: + 1 847 273 7700
Fax: + 1 847 273 7804

ACS New Berlin – Manufacturing Facility

2900 S. 160th Street
New Berlin, WI 53151
Phone : +1 262 641 8600
Fax: + 1 262 641 8653

Asia/Australia:

ACS Suzhou

109 Xingpu Road SIP
Suzhou, China 215126
Phone: + 86 8717 1919
Fax: +86 512 8717 1916

Europe/Middle East/Africa:

ACS Warsaw

Ul. Działkowa 115
02-234 Warszawa
Phone: + 48 22 390 9720
Fax: +48 22 390 9724

India

ACS India

Gat No. 191/1, Sandbhor Complex
Mhalunge, Chakan, Tal Khed,
Dist. Pune 410501, India
Phone: +91 21 35329112
Fax: + 91 20 40147576

Table of contents

1. Safety instructions	5
1.1. Warnings and symbols	6
1.2. Explanations and information	7
1.3. For your safety	8
1.4. For the safety of the equipment	8
2. Installation instructions	9
2.1. Transport	10
2.2. Set-up	10
2.3. Compressed-air supply (only with compressed-air valves)	11
2.4. Electrical connection	12
3. Functional description	14
4. Maintenance	15
4.1. Maintenance intervals	17
4.2. Servicing the hopper loader	17
4.2.1. Replace the sealing rings	18
4.2.2. Adjust the flap switch	20
4.2.3. Replacing the filter cartridge	21
4.2.4. Cleaning the hopper	22
5. Spare parts list	23
6. Technical data	27

1. Safety instructions



These safety instructions apply to all persons within the range of action of the equipment.

Please inform all persons within the range of action of the equipment of the direct and indirect hazards connected with the equipment.

These operating instructions are to be used by all persons assigned activities connected with the equipment.

Knowledge of the English language is prerequisite.

Ensure in each case that the operating personnel are familiar with the operating instructions and the function of the equipment.

Observe the safety instructions of the connected conveying system.

1.1. Warnings and symbols

The following warnings and symbols are used in these operating instructions:



This symbol indicates danger to life! Fatal or serious injury is possible if the corresponding instructions, regulations or warnings are not observed.



This symbol indicates that serious injury is possible if the corresponding instructions, regulations or warnings are not observed.



This symbol indicates that extensive damage to equipment is possible if the corresponding instructions, regulations or warnings are not observed.



This symbol indicates information important for becoming familiar with the equipment, i.e. technical correlations.



This symbol indicates that a technical term is explained at this point.

1.2. Explanations and information

Various terms and designations are used frequently in these operating instructions to ensure clarity. Therefore please note that the terms used in the text stand for the corresponding explanations listed below.

- **Equipment**
“Equipment” can mean an individual unit, a machine or an installation.

- **Operating personnel**
The “operating personnel” are persons operating the equipment on their own responsibility or according to instructions (minimum age: 16).

- **Operator**
The “operator” of the equipment (production manager, foreman, etc.) is the person responsible for all production sequences. The operator instructs the operating personnel of what is to be done.

- **Operating instructions**
The “plant operating instructions” describe the interaction of the equipment, production sequences or methods. The plant operating instructions must be compiled by the operator of the equipment.

- **Equipment foreman**
When several operating personnel work on one machine, the “equipment foreman” coordinates the sequences. The equipment foreman must be appointed by the operator.

- **Trained personnel**
“Trained personnel” are persons who, due to their training, are authorized to carry out the required work in good practice.

1.3. For your safety

- It is absolutely necessary that you observe the operating instructions for the corresponding conveying system.
- The device is intended exclusively for conveying plastic granules and regrind. Any other usage is not permitted.
- This device is not suitable for processing foods.
- Before beginning maintenance work, set all compressed air piping on the device at zero pressure. Danger of accidents!
- The device may only be operated if all corresponding components have been properly connected and are in accordance with the relevant regulations.

1.4. For the safety of the equipment

- It is absolutely necessary that you observe the operating instructions for the corresponding conveying system.
- For the operation of the hoppers, a compressed-air supply is necessary.
- Never set the operating pressure of the hoppers at more than 6 bar (87.02 PSI) (system overpressure).
- Install the hoppers in such a way that the outlet flap is hinged in a right angle to the direction of movement of the machine.
- Make sure that all plugs are connected properly.
- Observe the carrying capacity of the machine flange.

2. Installation instructions



These installation instructions are intended for persons with skills in electrical and mechanical areas due to their training, experience and received instructions.

Personnel using these installation instructions must be instructed in the regulations for the prevention of accidents, the operating conditions and safety regulations and their implementation.

Ensure in each case that the personnel are informed.

The installation instructions provided in the corresponding operating instructions apply for all connected equipment.

Observe safety regulations with regard to lifting gear handling

All installation work must be carried out with the equipment disconnected from electrical power and compressed air supply.



For installation work taking place at heights of over approx. 6 feet, use only ladders or similar equipment and working platforms intended for this purpose. At greater heights, the proper equipment for protection against falling must be worn.

Use only suitable lifting gear which is in proper working order and load suspension devices with sufficient carrying capacity. Do not stand or work under suspended loads!

Use suitable workshop equipment.



Install the equipment such that all parts are easily accessible; this facilitates maintenance and repair work.

2.1. Transport

For transport, only the appropriate lifting gear should be used (e.g. fork lift or workshop crane).



Observe the carrying capacity of the lifting gear.
Observe the safety instructions for the handling of lifting gear.

2.2. Set-up

The arrangement of the hopper loaders may vary depending on the type of device to be conveyed on and the material used. Fastening onto fixed machine throats is provided by means of strap retainers. However, additional support of the hopper loader is necessary if the devices are not sufficiently capable of bearing the load.

Mount the hopper loader in such a way that the outlet flap swings in a right-hand angle to the direction of machine movement. Please check during assembly that the admissible bearing loads are not exceeded.

Please check that all connecting points are tight to ensure that the conveying performance is not impaired.

It should moreover be observed, particularly if custom produced connecting parts are used, that the material discharged from the hopper loader must neither get into the open nor must it clog the filter surfaces (observe angle of repose!).



Do not excessively load inlet nozzle of hopper loader, remove hose separately, if necessary!

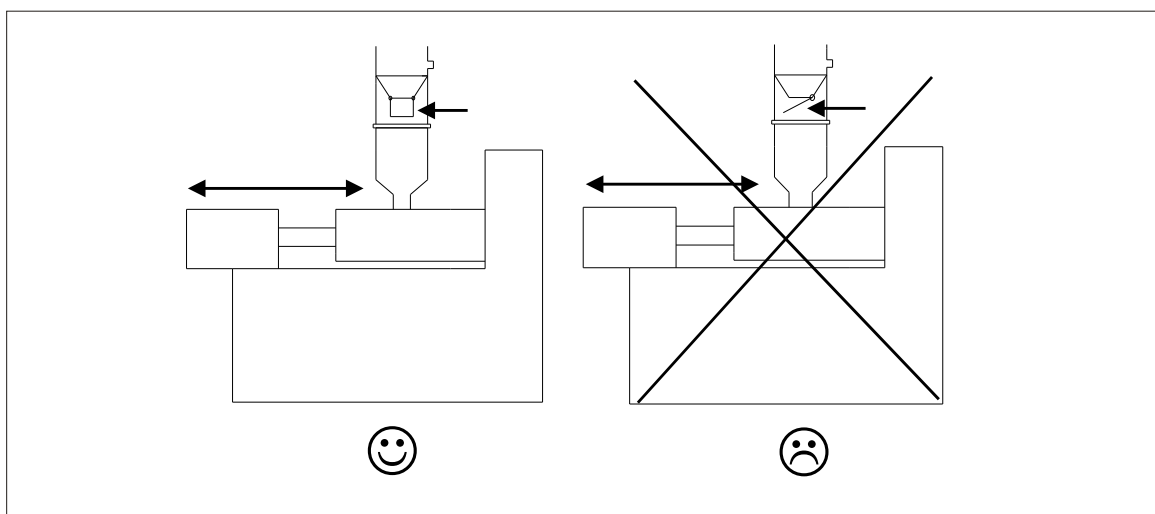

Assembly

2.3. Compressed-air supply (only with compressed-air valves)

For operating the control valves, a compressed-air supply is necessary.

Check compressed-air piping for correct installation and assembly.

Check fittings, length and quality of the hose connections for agreement with requirements.

The operating pressure is 5-6 bar (72.52-87.02 PSI) (system overpressure).

Check the compressed-air supplied by the plant's supply network.

Adjust compressed-air pressure to 5-6 bar (72.52- 87.02 PSI) (system overpressure).

Connect the unit to the plant's supply network by means of a hose.

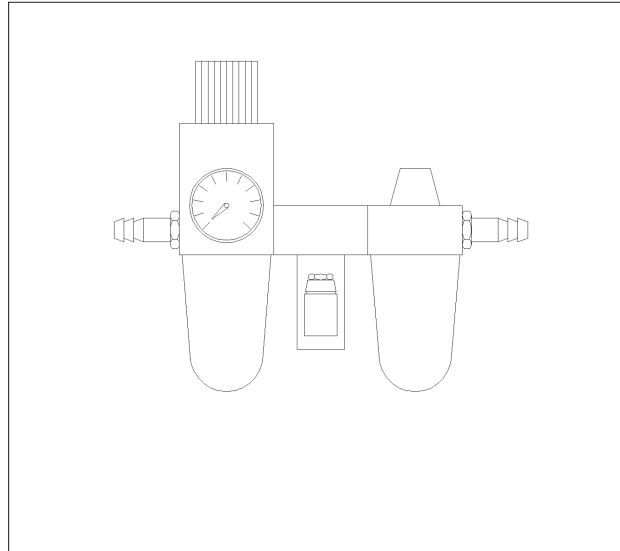

Maintenance unit



Depressurize compressed-air supply lines which must be opened.



Compressed air must be dewatered, dust-free and oil-free.

Install a maintenance unit if required.

Adjust pressure to a max. value of 6 bar (87.02) PSI (system overpressure).

2.4. Electrical connection



The electrical connection may only be carried out by trained personnel.

Other persons are not permitted to carry out the electrical connection.

The rules of the local electricity board must be observed.

Before beginning the electrical connection, make sure that the mains voltage and the power frequency are in accordance with the data on the name plate of the device.

All work may only be carried out when the unit is at zero voltage and at zero pressure.

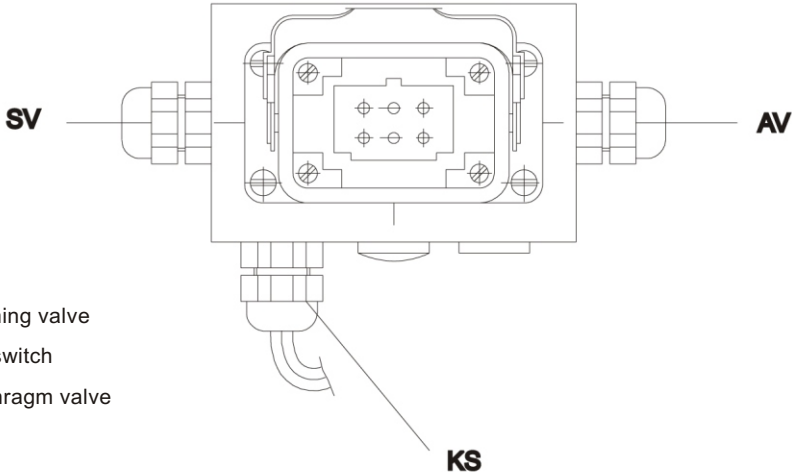

AV = cleaning valve
KS = flap switch
SV = diaphragm valve

- 1 = flap switch (KS)
- 2 = cleaning valve (AV)
- 3 = diaphragm valve (SV)
- 4 = KS
- 5 = AV
- 6 = SV

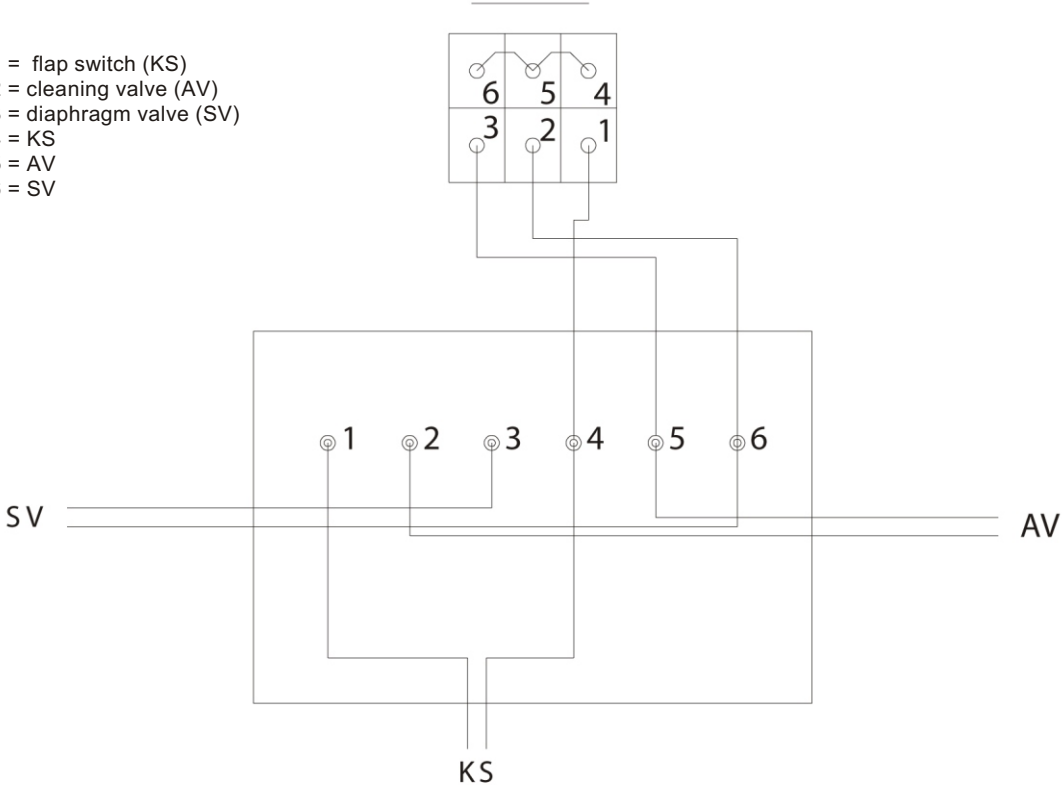

3. Functional description

The conveyor hopper is used for the automatic conveyance of thermoset duroplast material as well as thermoplastic powder.

The hopper can only function in connection with a vacuum conveyor plant.

The hopper works with a filter cartridge. The shut-off valve of the vacuum line is operated with compressed air (compressed-air valve). The automatic filter cleaning is achieved by intense vibration.

4. Maintenance



This chapter is intended for persons with skills in electrical and mechanical areas due to their training, experience and received instructions.

Personnel using the instructions in this chapter must be instructed of the regulations for the prevention of accidents, the operating conditions and safety regulations and their implementation.

Ensure in each case that the personnel are informed accordingly.

For maintenance work taking place at heights of over approx. 1828.8 mm (6 ft), use only ladders or similar equipment and working platforms intended for this purpose. At greater heights, the proper equipment for protection against falling must be worn.

Use only suitable lifting gear which is in proper working order and load suspension devices with sufficient carrying capacity. Do not stand or work under suspended loads!

Ensure that the electric motors/switch cabinets are sufficiently protected against moisture.

Use only suitable workshop equipment.

Before starting maintenance work, appoint a supervisor.

Inform the responsible personnel before maintenance work on the system is started.

Never operate the equipment when partially dismantled.

All maintenance and repair work not described in this chapter may only be carried out by Sterling service personnel or authorized personnel (appointed by Sterling).



Disconnect the equipment from mains supply before starting maintenance procedures to ensure that it cannot be switched on unintentionally.

Depressurize all compressed air piping of the equipment before starting maintenance work.



Please observe the maintenance intervals.

Before starting maintenance work, clean the equipment of oil, fuel or lubricants.

Ensure that materials and incidentals required for operation as well as spare parts are disposed of properly and in an environmentally sound manner.

Use only original Sterling spare parts.

Keep record of all maintenance and repair procedures.

4.1. Maintenance intervals

- Daily: check warning signs on equipment for good legibility and completeness.
- with compressed-air valve:
check the oil level in the oiler
empty the water separator
check the operating pressure in the factory ductwork system (max. 6 bar (87.02 PSI) system overpressure)
- Every six months: check all electrical and mechanical connections for proper fit
check the settings of the level probes (if available)
check the sealing rings on the locking flaps
- Yearly: replace the sealing rings on the locking flaps
replace filter cartridge (depending on amount of dust)



The given maintenance intervals are average values.

Check whether in your individual case the maintenance intervals must be shortened.

4.2. Servicing the hopper loader



Individual hoppers can also be maintained during operation. However, Sterling recommends that you switch off the conveying plant for all types of work on the hopper.

Wait until the conveying procedure has stopped.

Disassemble the vacuum line on the hopper.

Close the disassembled vacuum line so that the vacuum for the active hopper-loaders does not break down.

Depressurize the compressed-air line to the hopper (only with compressed-air valve).

Disassemble the material line on the lateral inlet of the hopper.

Disassemble the hopper.

4.2.1. Replace the sealing rings

Nonreturn valve

Loosen the tightening strap at the hopper lid.

Remove the hopper lid .

Draw the old sealing ring off the nozzle (A).

Install the new sealing ring. Observe the direction of installation (B).

Mount the hopper lid.

Mount the tightening strap.

Install the hopper.

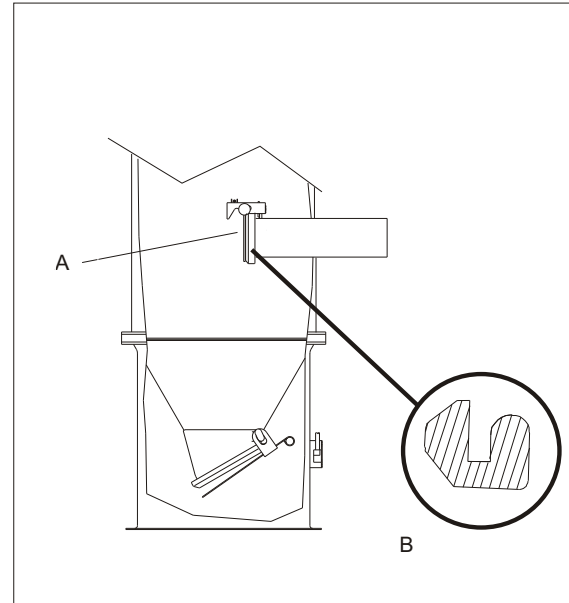

SSK 5-DURO



Order number sealing ring: ID 85610

Outlet flap

Draw the old sealing ring off the nozzle of the material outlet.

Install the new sealing ring.

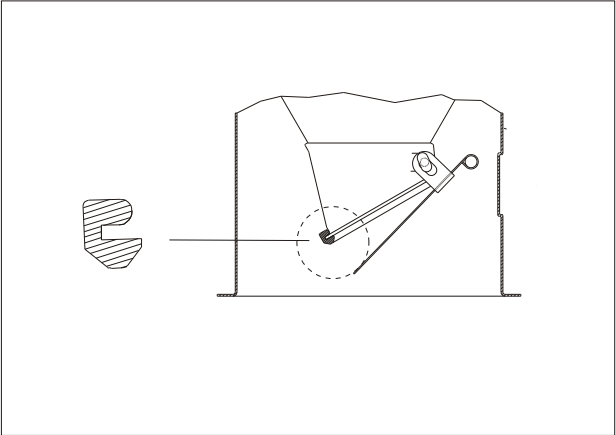

Outlet flap



Observe the direction of installation.

Install the hopper.



Order number sealing ring: ID 23098

4.2.2. Adjust the flap switch

Remove the connecting plug “flap switch” from the connection housing of the hopper.

Connect an ohmmeter to PINS 1 and 4 of the connecting plug “flap switch”.

Release the nuts (A) of the flap switch (B) until the support can be displaced.

Open the outlet flap (C) so far that the front tip of the outlet flap is approx. 35-40 mm (1.48-1.67 in.) away from the sealing surface.

Displace the flap switch (B) until the contact of the magnet switch is closed.

Tighten the nuts (A) of the flap switch.

Check the adjustment:

In case of free hanging outlet flap (empty hopper loader) the contact of the magnet switch must be closed.

If the outlet flap cannot be properly adjusted, replace the flap switch or the outlet flap with magnet.

Install the hopper.

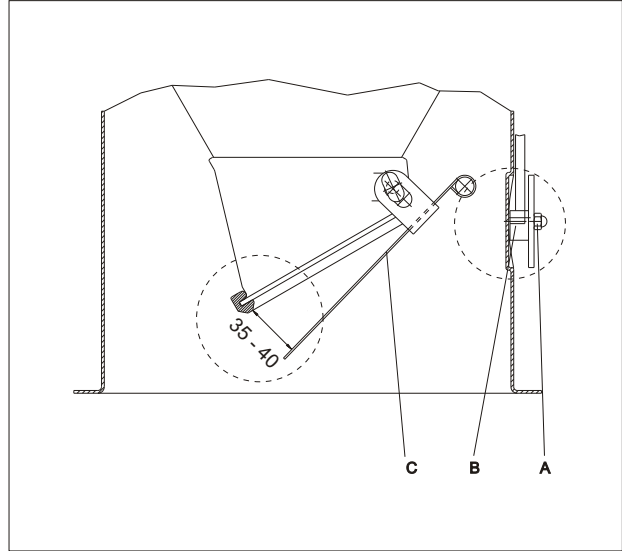

Flap switch



Order numbers

flap switch:	ID 28839
outlet flap with magnet:	ID 23093

4.2.3. Replacing the filter cartridge

- Loosen the tightening strap (A).
- Remove the hopper lid (B).
- Remove the locking pin from the threaded rod (C).
- Loosen the 2 flat nuts (D) and remove the safety plate (E).
- Remove the washer (F).
- Pull the filter cartridge (G) from the threaded rod.
- Use compressed air to blow through the filter cartridge from inside out **or** replace the old filter cartridge.

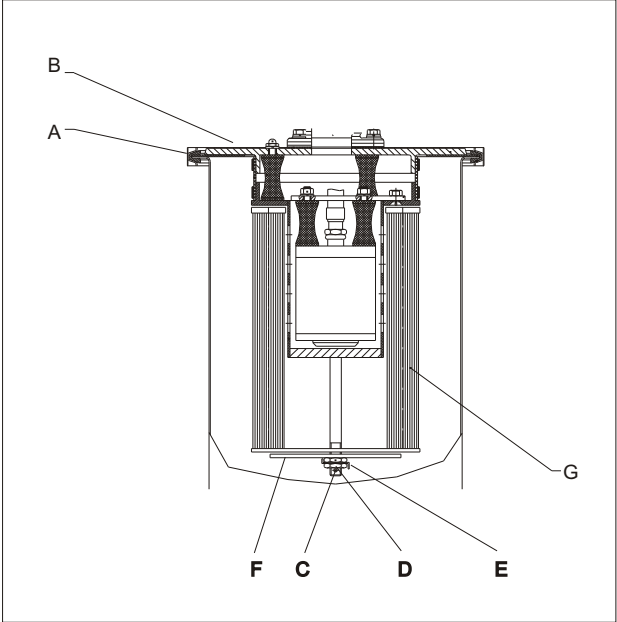

SSK 5-DURO

- Put the new filter cartridge/cleaned filter cartridge (G) onto the threaded rod.
- Mount the washer (F) and a flat nut (D).
- Put back the safety plate (E).
- Mount the second flat nut (D).
- Put a new locking pin in the threaded rod (C).
- Mount the hopper lid (B).
- Mount the tightening strap (A).
- Install the hopper.



Order numbers	
filter cartridge:	ID 85612
locking pin:	ID 96093

4.2.4. Cleaning the hopper

Loosen the tightening strap.

Remove the hopper lid.

Clean the hopper loader by means of a vacuum cleaner.

Mount the hopper lid.

Mount the tightening strap.

Open the toggle-type fasteners (A) on the flap of the hopper loader.

Check the filter cloth (B) and the wire cloth (C) for material residue. Clean the filters by means of compressed air.

Close the toggle-type fasteners (A) on the flap of the hopper loader.

Install the hopper.

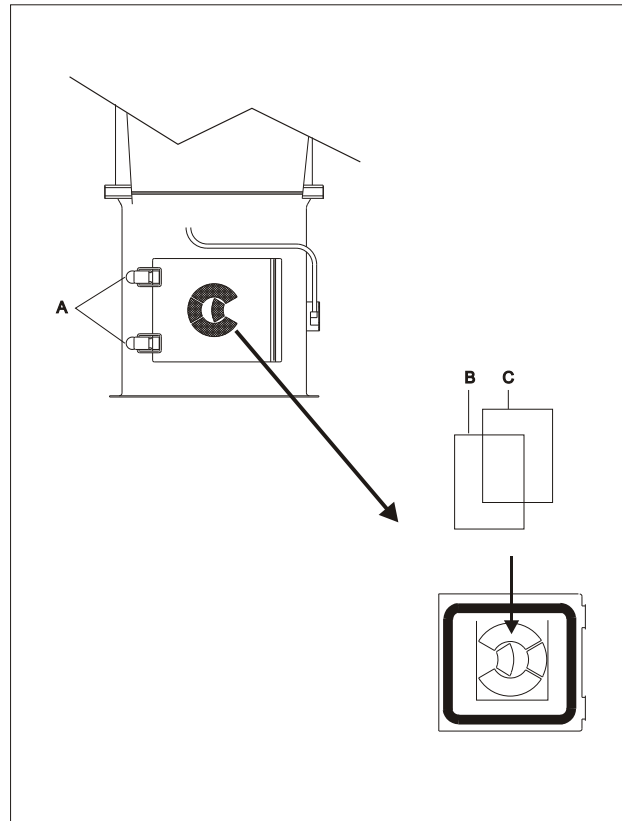

SSK 5-DURO

5. Spare parts list



This parts list is only for the use of trained personnel only.
All other persons are not permitted to repair or to change the equipment.



Wear Code:

A = Wearing part, fast used up

B = Wearing part

C = Spare part, storekeeping for 1 year

D = Spare part, storekeeping for 2 years

E = Spare part, storekeeping for more than 2 years

V 66412 SSK 5-DURO, complete

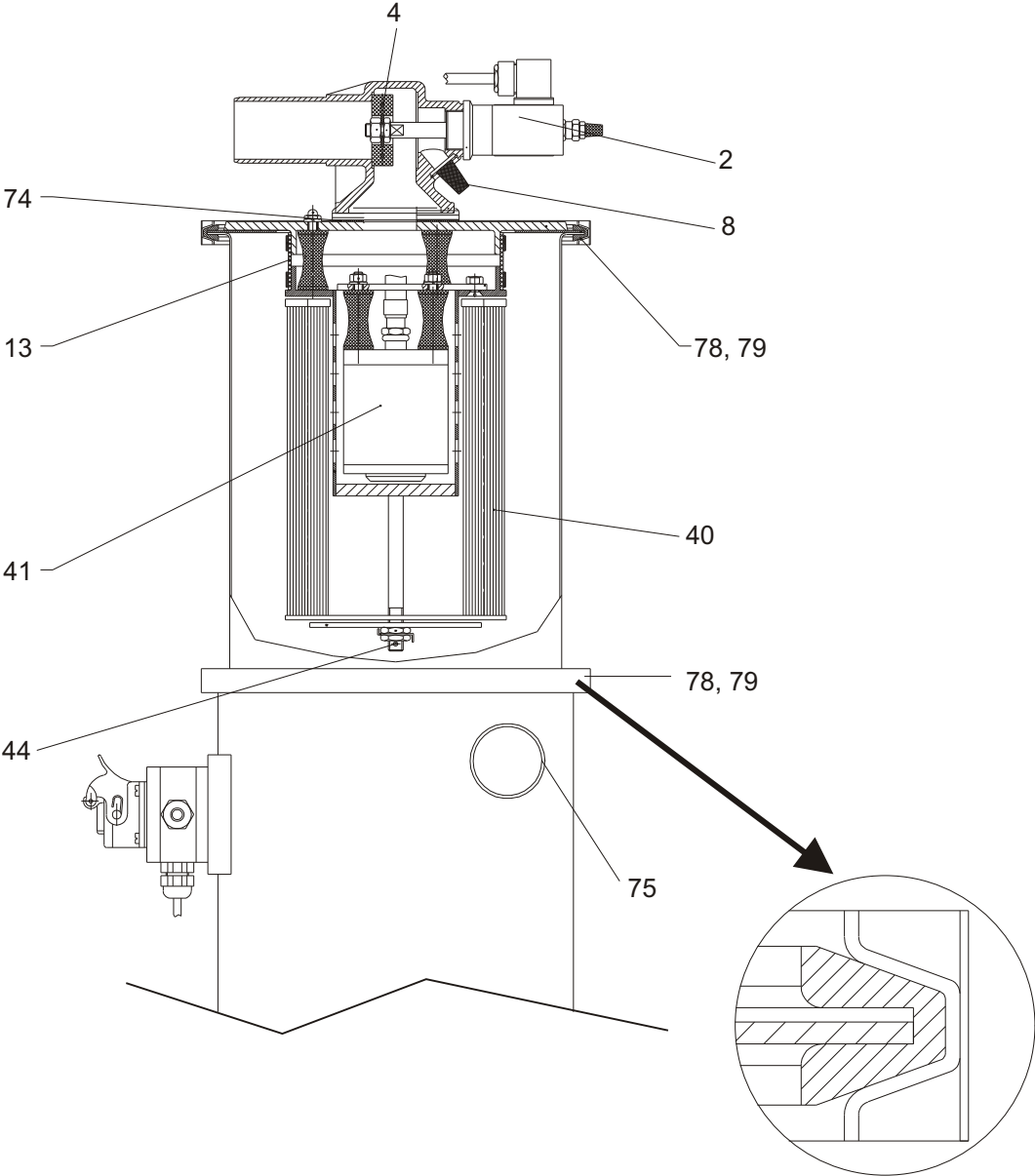

SSK 5-DURO

Pos.	Order no.	Designation	Wear Code
	26487	compressed-air valve, complete	E
	26491	diaphragm valve, complete	
2	23066	cylinder with valve	C
4	09646	sealing ring	C
8	85489	sieve	C
13	02128	hose	C
40	85612	filter cartridge	B
41	03141	vibrator	C
44	96093	locking pin	B
74	13021	sealing	E
75	85610	sealing	B
78	85533	tension ring	E
	26451	fastener	E
79	28420	sealing ring	C

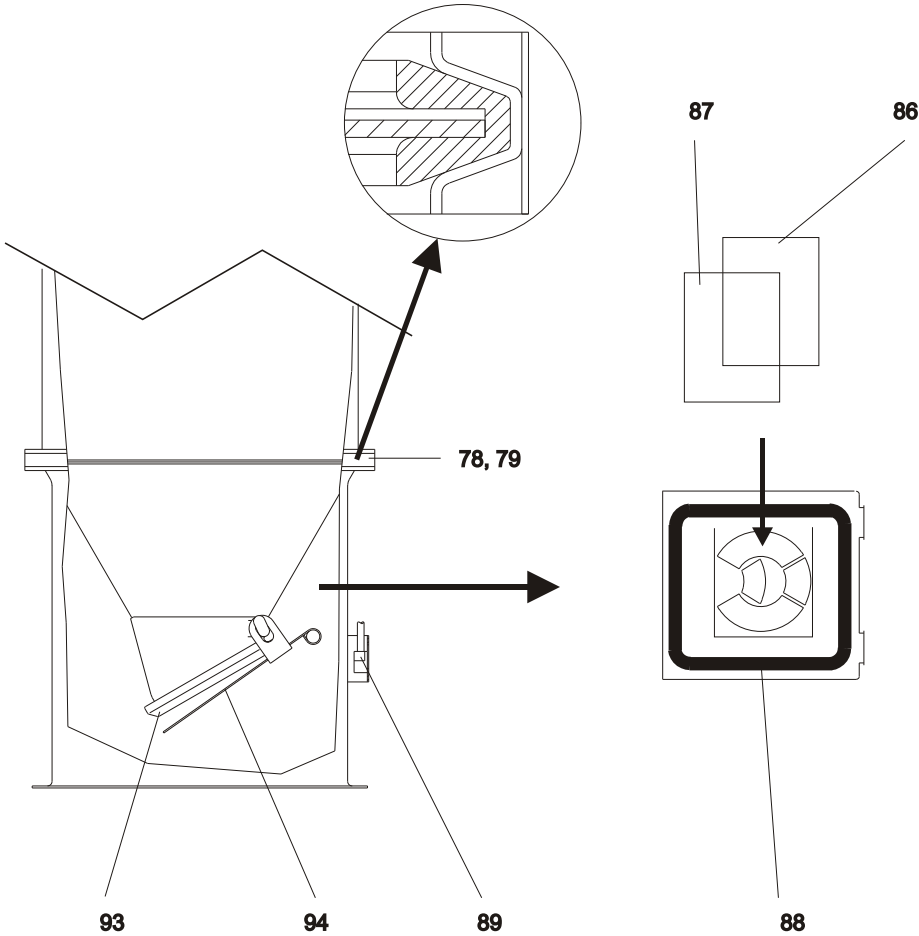

Pos.	Order no.	Designation	Wear Code
78	85533	tension ring	E
	26451	fastener	E
79	28420	sealing ring	B
86	23091	wire cloth	C
87	28626	filter cloth	C
88	28625	sealing	B
	28839	flap switch with plug and cable	D
89	26462	cover	D
	23098	sealing ring	B
94	23093	outlet flap with magnet	E

SM3-615a

6. Technical data

Dimension Sheet

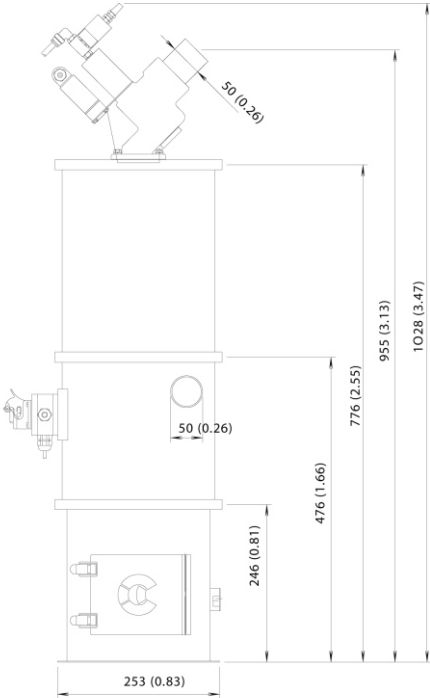

64.10-0215GB01 10/01

Dimensions and data without obligation. Dimensions in mm (in.) Specifications may be subject to alterations.

Electrical manual



This electrical manual is intended to be used only by Sterling service personnel and trained personnel authorized by Sterling.

Other persons are not permitted to modify or repair the equipment.