

**TORO**

Wireless Rain Sensor Series  
Rain Sensor, Model TWRS-I and  
Rain/Freeze Sensor, Model TWRFS-I

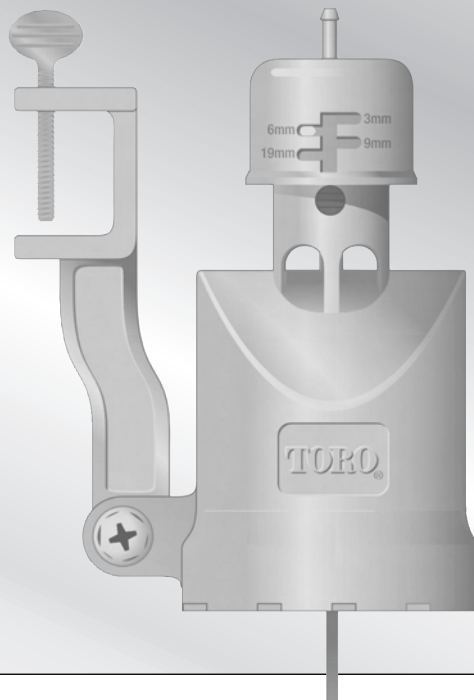

English

Español

Français

<b>Contents</b>	<b>Page</b>	<b>Contents</b> .....	<b>Page</b>
Getting Started .....	2	Water Delay Feature .....	16
Receiver Module Features .....	4	Signal Strength Display Feature .....	16
Installing the Receiver Module .....	5	Battery Strength Display Feature .....	17
Initial Sensor System Test .....	8	Dry Out Feature .....	18
Sensor Module Features .....	9	Fail Safe Feature .....	18
Rain Sensor Site Selection .....	10	Turn Receiver Module Off and On .....	20
Installing the Sensor Module .....	11	Set or Restore the Sensor Address Code .....	20
Freeze Sensor Site Selection .....	13	Sensor Module Battery Replacement .....	21
Set Centigrade or Fahrenheit Scale .....	14	Troubleshooting .....	22
Set Temperature Activation Threshold .....	14	Specifications .....	24
Water Conservation Feature .....	15	Warranty Information .....	25
Smart Bypass Feature .....	16		

## **Introduction**

The Toro wireless rain sensor system, model TWRS-I for rain sensing and TWRFS-I for rain and freeze sensing, is a powerful, water conservation and management tool that connects your automatic irrigation system to actual environmental factors vital to the health and maintenance of your landscape. Without sensor input, the controller simply turns the sprinklers on and off based on a routine irrigation schedule. Linking controller operation to real-time rain and/or freeze conditions eliminates unnecessary irrigation and dramatically reduces water consumption—all without compromising the health and beauty of your landscape. And—it’s wireless. No cable to run or holes to drill. Simple installation and setup delivers reliable, intelligent sensor control in a matter of minutes.

The wireless sensor system is comprised of a programmable, weather-resistant receiver module and a sensor module with built-in transmitter. The receiver installs next to the irrigation controller and connects to the controller's 24 Vac power source and sensor input terminals (if equipped) or splices directly into the irrigation valve common wire. The sensor module is installed within range of the receiver in a location that best represents the landscape's sun/shade exposure and can provide reliable communication from the sensor to the receiver.

Once activated by preset rain or low temperature levels (rain/freeze model only), the sensor communicates to the receiver via ultra high-frequency radio signal. The receiver responds by placing the controller's automatic watering schedule on hold or by simply opening the valve common circuit to prevent sprinkler operation. When watering is once again needed, the sensor system automatically resets, allowing automatic irrigation to resume.

More than just an accurate rain switch, the wireless sensor system actually adapts to your landscape with the simple, yet sophisticated Water Conservation feature. Just choose the conservation level that corresponds to your landscape soil type and the sensor location.

A dry-out period, adjusted for actual rainfall duration, is automatically placed after the sensor system resets to effectively delay automatic watering until it is actually needed.

Other standard features include a Smart Bypass™ button that gives you manual control over the sensor system with a single touch, system status indicators to see at glance that your sensor system is active and watering is on hold, watering delay to postpone automatic watering from 1 to 5 days, air temperature displayed for rain/freeze sensors and even a Fail-safe mode to allow irrigation in case the sensor system is not performing properly.

## Getting Started

The wireless rain sensor system is designed for easy installation, setup and years of trouble-free operation. In most cases, the system components can be installed and fully operational within minutes. All you will need is a Phillips screwdriver and basic do-it-yourself skills.

If you have problems with any portion of the installation, or the product does not seem to function properly, refer to the Troubleshooting section on page 22 first. If the problem is not listed, or the remedy does not help, call Toro Irrigation at 1-951-688-9221 or contact your local Toro distributor for assistance. For more information on this and other Toro irrigation products, visit the Toro web site at [www.toro.com](http://www.toro.com).

**Here's all there is to it:**

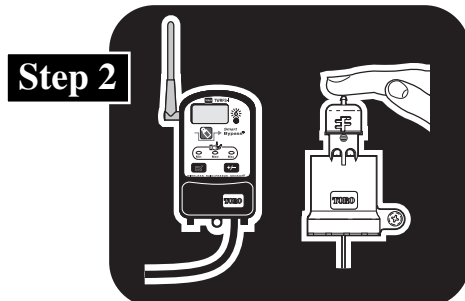
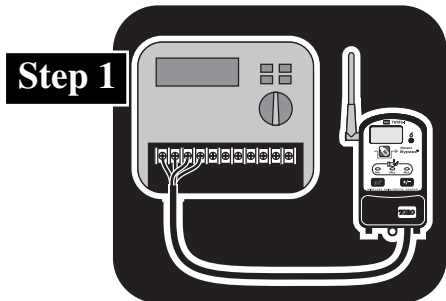

The receiver is installed and connected to your irrigation system controller. **See page 5.**

The sensor and receiver are tested at close range to verify operation. **See Page 8.**

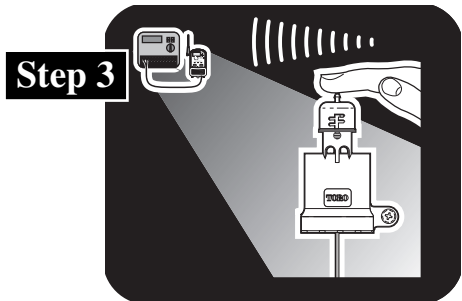

A sensor installation site is chosen and the system is tested again to verify operation. **See page 10.**

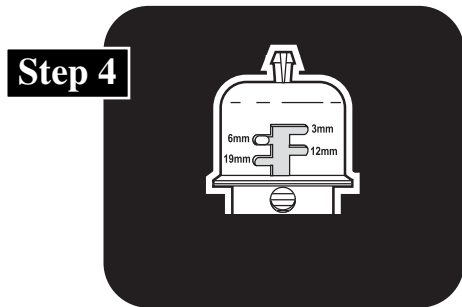

The sensor is adjusted to the preferred rainfall activation level. **See page 11.**

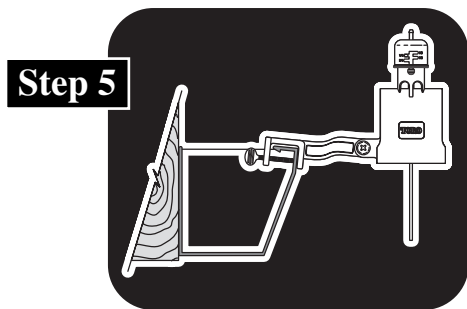



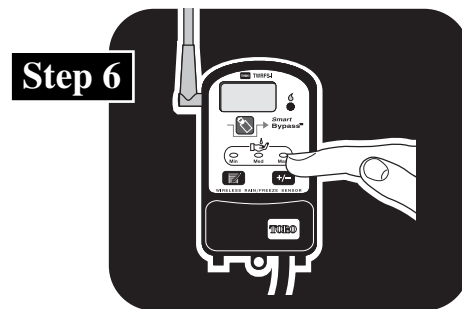



The sensor module is installed. **See page 11.**



The operating features are set to your preferences. **See page 14.**

## Receiver Module Features

- 1—  **Setup Button**—Accesses the receiver setup and operating features.
- 2—  **Adjust Button**—Selects settings within the receiver setup and operating features.
- 3— **Mast Antenna**—Adjusts easily for best signal reception.
- 4— **Digital Display**—High-resolution LCD screen provides visual reference for sensor system operating features.
- 5— **Sensor Status Indicators**—  Rain status and  Freeze status (TWRFS-I only) indicators illuminate when the sensor system is active and automatic watering is on hold.
- 6—  **Smart Bypass™ Button**—Multi-functional use. Pressed to bypass sensor operation, allowing automatic watering to resume. Switches the Water Delay feature on and off.
- 7—  **Water Conservation LEDs**—Indicate the Water Conservation feature level selected (Minimum, Medium or Maximum).
- 8— **Hinged Cover**—Opens downward for receiver control access. Closed position protects receiver when installed outdoors.

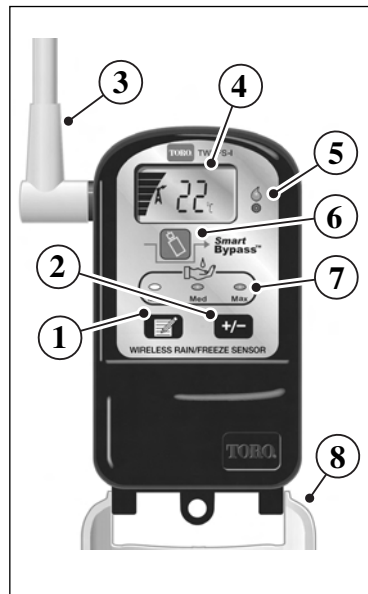

## Installing the Receiver Module

**⚠ Important:** Installation of this product must comply with national and local building and electrical codes. For assistance, contact a professional irrigation system contractor in your area.

The receiver module is suitable for either indoor or outdoor installation. Select a location next to the controller that provides the following conditions:

- The display screen is clearly visible and the control buttons are easily accessed.
- The connection cable can reach the controller wiring terminal strip without straining.
- The antenna will be unobstructed and is able to be adjusted.

1. Install one of the provided stainless steel screws into the wall at the intended receiver location. Leave a 3mm gap behind the screw head.

**Note:** Use screw anchors if installing the receiver on drywall or masonry.

2. Hang the receiver on the screw ensuring the keyhole slot drops down onto the screw shaft.
3. Install a second screw through the lower tab to secure the receiver.
4. Route the connection cable through the bottom of the controller cabinet to the wiring connection terminals.

**⚠ Important:** If the receiver module is installed outdoors, be sure to keep the cover in the closed position when you do not need to view the display or access the control buttons.

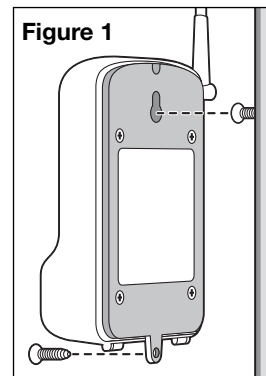

## Connecting the Receiver Wires

**▲ CAUTION:** The receiver requires continuous 24 Vac power for operation. Connecting to higher power will result in irreparable damage. Ensure that power to the controller has been removed prior to connecting the receiver wires.

The sensor system is designed to work with most makes and models of irrigation controllers.

- If your controller is equipped for a sensor connection, follow the steps in **Wiring Procedure I**.
- If your controller is not equipped for a sensor connection, use **Wiring Procedure II** on page 7.

### Wiring Procedure I (sensor-ready)

**Note:** Refer to your controller user's guide to determine the type of sensor required: Normally Closed (NC) or Normally Open (NO).

1. Locate the sensor connection terminals, usually labeled "SENSOR" or "SN."  
Remove the jumper connector (if installed).
2. Attach the **White** wire to either Sensor terminal (disregard +/- polarity if labeled).
3. For a **Normally-Closed** sensor type, attach the **Brown** wire to the remaining Sensor terminal. Tape back the Yellow wire. See Figure 2.

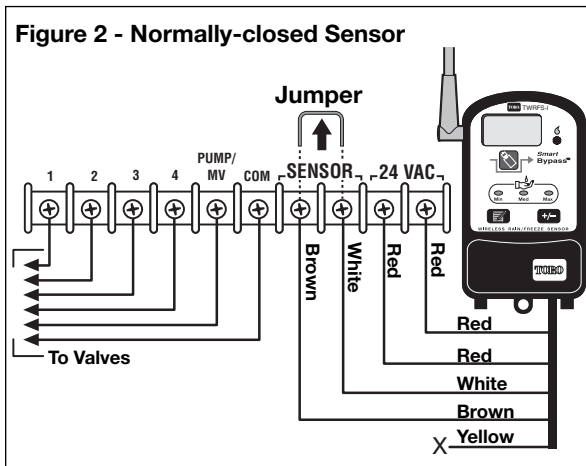



For a **Normally-Open** sensor type, attach the **Yellow** wire to the remaining Sensor terminal. Tape back the Brown wire. See Figure 3.

4. Attach the two **Red** wires to the 24 Vac terminals in either order.

**⚠ Important: Most controllers equipped for sensor connection provide a switch to control the sensor circuit. Check the switch setting to ensure that it is not in the Bypass or Off position.**



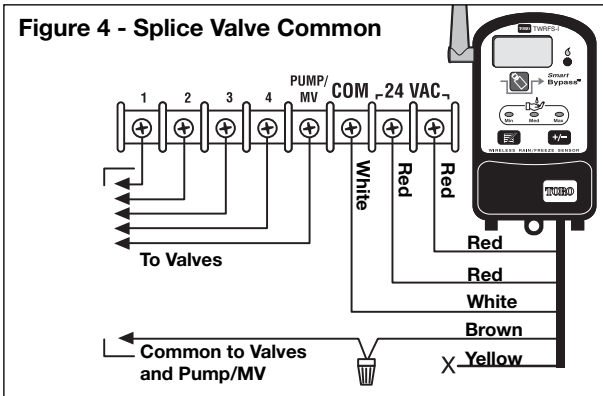
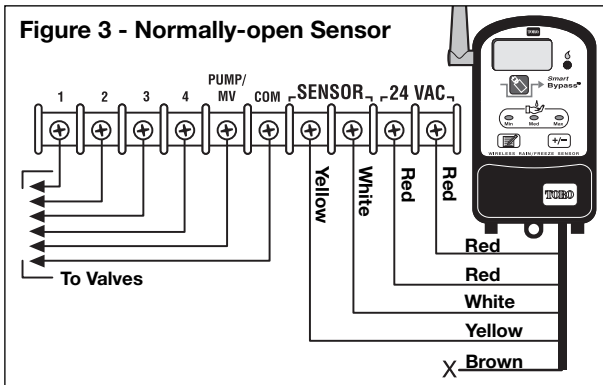

### Wiring Procedure II (no Sensor terminals)

1. Locate the valve common wire terminal, generally labeled “C” or “COM”, and remove the attached common wire(s).
2. Attach the **White** wire to this terminal.
3. Splice the **Brown** wire to the common wire(s) using a wire nut or electrical tape. Tape back the Yellow wire. See Figure 4.
4. Attach the **Red** wires to the 24 Vac terminals.



## Initial Sensor System Test

Before installing the sensor module, test the sensor system to verify operation. Once this test has been completed satisfactorily, the sensor module can be installed. If a problem occurs during the test procedure, refer to “Troubleshooting” on page 22.

1. Apply power to the controller. Check controller operation to confirm that it is working properly.
2. When power is applied to the receiver, the “Min”  Water Conservation indicator will illuminate. The TWRS-I receiver will display alternating boxes and the TWRFS-I receiver will display two flashing bars as shown in Figures 5 and 6.
3. Holding the sensor module next to the receiver, press and hold the sensor test spindle down **for at least 15 seconds** to establish communication. See Figure 7. The  Sensor Status indicator will illuminate, the  Antenna icon will flash and the signal strength bars will appear. The TWRFS-I receiver will display the current air temperature. See Figure 8.
4. When the  Antenna icon stops flashing, release the test spindle. The receiver display will appear as shown in Figures 9 or 10.

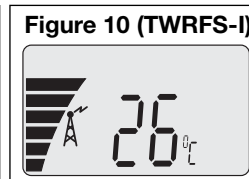
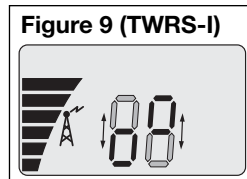
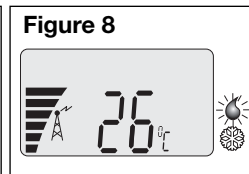
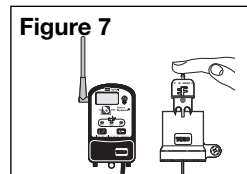
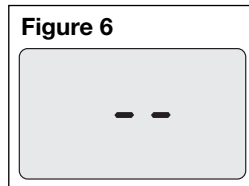
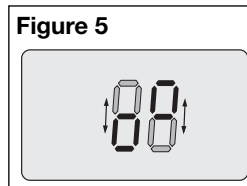

## Sensor Module Features

- 1– Rain Threshold Adjustment**–Adjusts the rain sensor to accumulate 3mm, 6mm, 12mm or 19mm of rainfall before signaling the receiver to hold watering. The factory default setting 6mm.
- 2– Sensor Test Spindle**–Pressed to manually activate the sensor for setup and test procedures.
- 3– Batteries** (not shown)–Two 3V lithium batteries, installed at time of manufacture, will provide approximately five years of service under normal use conditions.
- 4– Antenna**–Positioned downward for maximum signal transmission strength.
- 5– Pipe-mount Adapter**–Replaces Quick Clip mounting bracket to enable installation on a length of 13mm thick-wall PVC pipe.
- 6– Quick Clip™ Mounting Bracket**–Simplifies sensor module installation. Adjustable pivot point for easy vertical alignment.

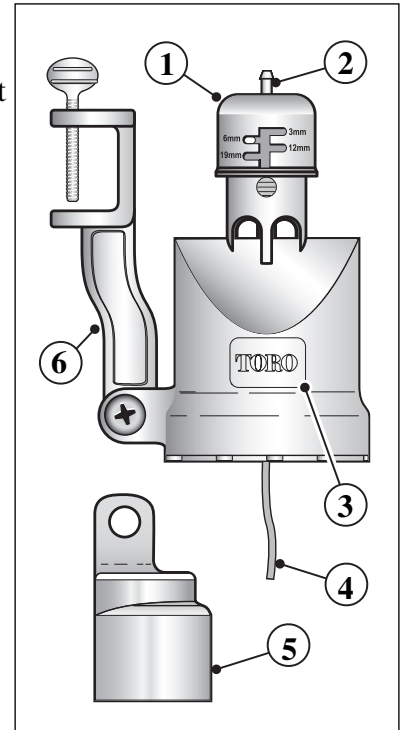

## Rain Sensor Site Selection

Choosing the right installation site for the sensor module is key to obtaining the maximum benefit from your sensor system. For best results, choose a sensor installation site that provides:

- Unobstructed exposure to rainfall—away from overhangs, tree branches, etc.
- Protected from irrigation spray, rainwater accumulation and the possibility of submersion.
- Exposure to sunlight and shade conditions similar to the landscape being watered.
- Good communication signal from the sensor to the receiver.

**Note:** If installing a TWRFS-I rain/freeze sensor specifically for freeze detection, refer to the additional site selection criteria provided on page 13.

Before installing the sensor module, test the system again to confirm operation by using the following test procedure:

1. Activate a watering zone that is visible from the intended sensor installation site.  
**Note:** The manual operation mode of some irrigation controllers may bypass the sensor circuit. If your controller operates like this, set an automatic cycle to start within a minute or two.
2. With the sprinklers on, press and hold the sensor test spindle until the sprinklers shut off.  
**Note:** Irrigation control valves close at various rates. It may require several seconds for the sprinklers to shut off.

If the test is successful, the sensor is ready to install. If the sprinklers do not shut off, try moving the sensor a few feet in either direction and test again. Rotating the receiver antenna slightly may improve the signal strength. Refer to “Troubleshooting” on page 22 for additional information.

## Installing the Sensor Module

1. Adjust the sensor module to the preferred rainfall threshold activation point. The settings, provided in metric on one side of the cap and U.S. standard on the other, include 3mm, 6mm, 12mm and 19mm. The factory setting is 6mm and is generally a good starting point. The 3mm setting is not recommended for high humidity or foggy locations. To adjust, turn the cap to align the stationary pin with the vertical slot. Guide the cap to the preferred slot position, then turn it just enough to engage the pin.

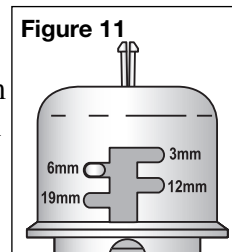

2. To install the sensor module on a rain gutter, position the Quick Clip bracket on the outer edge of the gutter and secure by tightening the thumb screw (Figure 12). Use the provided stainless steel screws when installing the sensor on a solid structure, such as a fence or the side of a roof. See Figure 13.

**Note:** For optimum signal strength, the antenna wire should hang straight down. Ensure the antenna is not in contact with any metal objects .

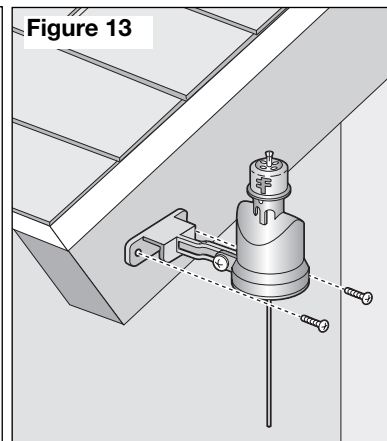
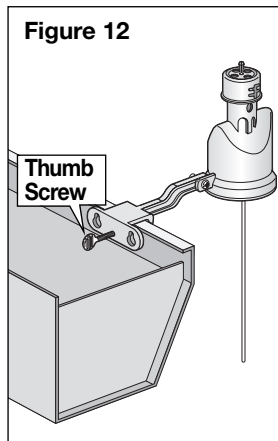

3. To install the sensor on a length of thick-walled PVC pipe, remove and replace the Quick Clip bracket with the pipe-mount adapter. To provide friction between the components, ensure the star washer is installed between the adapter and housing tab as shown in Figure 14.
4. Check the sensor module for vertical alignment. To adjust, loosen the bracket screw slightly, align vertically and tighten screw. See Figure 15.

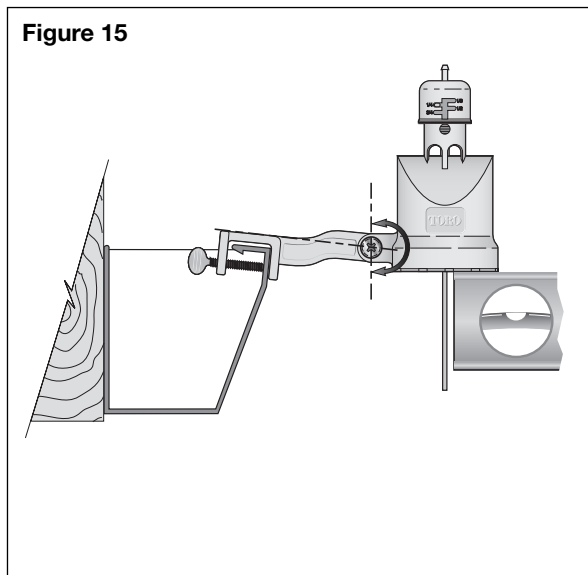
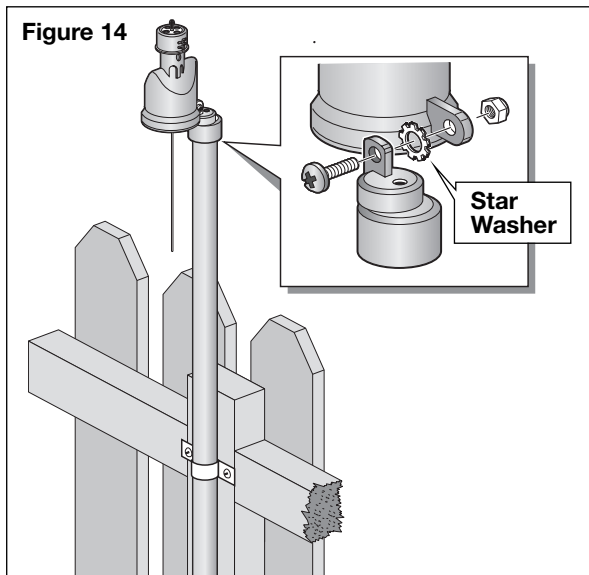

## Freeze Sensor (model TWRFS-I) Site Selection

To ensure optimum freeze sensor operation, the sensor module installation site should meet the site criteria of the rain sensor in addition to the following conditions:

- Located in the coldest portion of the landscape.
- Away from direct exposure to morning sunlight.
- Away from any heat producing or storing device, equipment or appliance such as a pool/spa, heater, water heater, chimney or hot air vent pipe.

**⚠ CAUTION: The freeze sensor should be regularly inspected for freeze damage and manually tested to ensure proper operation.**

**The freeze sensor system is NOT intended for farm/crop freeze protection and must not be used for this purpose.**



**⚠ Important:** Visual checks and prudent manual watering suspension must be used in conjunction with any freeze sensor. A freeze sensor should only be relied upon as an aid to conscientious watering practices, including frequent visual checks.

Air temperatures may be above freezing while the ground and vegetation temperatures remain below freezing. Due to sensor location and sunlight exposure, actual air temperature may be lower than measured by the sensor. Operation of the sprinkler system during these conditions may cause icing. Freeze sensor response time may not coincide with extremely rapid temperature drop, enabling automatic irrigation to occur.

## Set Temperature Activation Threshold (TWRFS-I models only)



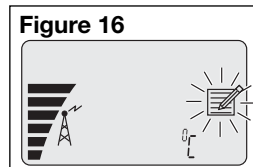

The freeze sensor temperature activation threshold is adjustable from 2°C to 7°C ( 35°F to 45°F). When the air temperature reaches the threshold setting, the freeze sensor activates the receiver, and the ❄️ Freeze Status indicator will turn on. The sensor system will return to the Monitor mode when the outside air temperature rises above the sensor threshold temperature.

## Select Centigrade or Fahrenheit Temperature Scale

1. Press the  Setup button to display the current temperature scale (°C or °F) and the  Setup icon will begin flashing to indicate the selected feature can be adjusted. See Figure 16.
2. To select the alternate temperature scale, press the  Advance button.



## Select Temperature Threshold

1. Press the  Setup button to display  Temperature icon. The display will indicate the current temperature threshold setting and the  Setup icon will begin flashing to indicate the selected feature can be adjusted. See Figure 17.
2. Press the  Advance button to set the sensor threshold temperature.

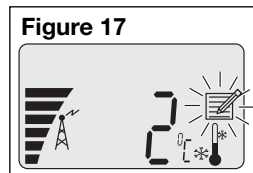

**Congratulations!** Your Wireless Rain Sensor system installation is complete. To take advantage of the unique Water Conservation feature, review the information on the next page to select the conservation level that best suits your landscape irrigation needs.



**Water Conservation Feature** – By simply choosing the Minimum (Min), Medium (Med) or Maximum (Max) conservation level that corresponds to your landscape’s soil type and the sensor location, a dry-out period, adjusted for actual rainfall duration, is inserted after the sensor system resets to delay the resumption of automatic watering.





Each conservation level represents a baseline value that is automatically adjusted to compensate for rainfall duration.

**Min** (display number **1**) – sets baseline at **no** days of delay.

**Med** (display number **2**) – sets baseline at **one** day of delay.

**Max** (display number **3**) – sets baseline at **two** days of delay.

To assist in choosing which conservation setting to use, review the chart in Figure 18. First select the landscape soil type. Now, drop down to the row that best describes the sun/shade coverage of the **sensor location**. The level indicated where the two conditions meet is the suggested starting point. That’s all there is to it!



1. Press the  Setup button to display the  Water Conservation icon. The display will indicate the current water conservation level setting and the corresponding level indicator will be illuminated. The  Setup icon will begin flashing to indicate the selected feature can be adjusted. See Figure 19.
2. Press the  Adjust button to select level 1, 2 or 3.

**Figure 18**

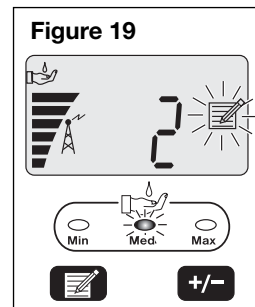
Suggested Conservation Mode Settings				
TORO		Soil Type		
		Sand	Silt	Clay
Sensor Location	Shade	Min	Med	Med
	Partial Sun	Min	Med	Max
	Direct Sun	Med	Max	Max



## Smart Bypass Feature



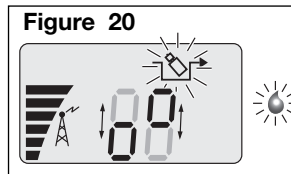



Once the rain sensor becomes active, it can be easily bypassed by pressing the  **Smart Bypass** button. When the rain sensor is bypassed, the  Sensor Status indicator and  **Smart Bypass** icon will begin flashing. See Figure 20.



The controller will resume automatic watering operations as scheduled. The rain sensor will stay in the Bypass mode until it automatically resets to the Monitor mode, or is returned to the active mode by pressing the  **Smart Bypass** button again.

## Water Delay Feature

The Water Delay feature provides a convenient method of postponing automatic irrigation from 1 to 5 days when rain (or freeze) conditions are expected.

1. Press the  Setup button to display the  Water Delay icon. The  Setup icon will begin flashing to indicate the selected feature can be adjusted. See Figure 21.
2. Press the  Adjust button to select 1.0 to 5.0 days.
  - To activate the Water Delay period, press the  **Smart Bypass** button. The number of days remaining in the Water Delay period will countdown as days pass. Automatic watering will resume as scheduled when 0.0 Water Delay days remain.
  - To cancel the Water Delay mode and resume automatic watering operations as scheduled, press the  **Smart Bypass** button again.

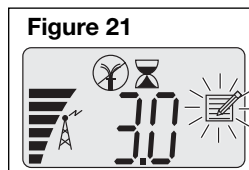

## Signal Strength Display

This feature displays sensor signal strength on a digital scale ranging from 0.0 to 10.2.

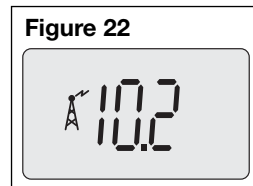

1. Press the  Setup button as needed to display the antenna icon and the digital readout. The display will indicate the strength of the last received signal. See Figure 22.





**⚠ Important:** A signal strength value less than 2.0 is may cause inconsistent operation. Relocate the sensor as needed to increase the signal strength. See “Troubleshooting” on page 22 for additional information.

## Battery Strength Display

This feature displays sensor battery strength on a bar scale. The strength of the battery is indicated by the height of the bar stack: No bar = a dead battery to six bars = full strength.

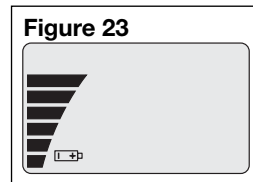
1. Press the  Setup button as needed to display the  Battery icon and the bar scale. See Figure 23.





**Note:** If the  Battery icon is flashing, low battery strength is indicated and replacement is recommended.

See “Sensor Module Battery Replacement” on page 21.

## Dry Out Feature

The Dry Out feature is provided to override the Water Conservation baseline level, allowing the dry-out delay period to be set with more accuracy from 0.5 to 4.0 days in 0.5-day increments.

**Note:** Before using the Dry Out feature, allow the sensor system to normalize by cycling through rain and/or freeze activation several times.

1. Press the  Setup button to display the  Dry Out icons.

The display will indicate the current Dry Out day setting (factory default is 0.0 days). The  Setup icon will begin flashing to indicate the selected feature can be adjusted. See Figure 24.

2. Press the  Adjust button to select the desired value (0.5 to 4.0 days).

**Note:** Once activated, the Dry Out mode can be canceled by pressing the  Smart Bypass button.

**Note:** Changing the Water Conservation level will override the Dry Out feature setting.

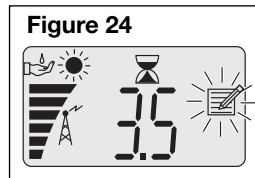

## Fail Safe Feature

The Fail Safe feature is provided to alert and respond to a loss of communication signal and/or if the sensor system stays in the active mode for a prolonged period of time. This important feature safeguards your automatic irrigation system from being inadvertently shut off for an indefinite period of time due to a rain sensor system malfunction.

## Loss of Communication

If the sensor and receiver do not communicate within a 24-hour period, the sensor system will remain in its current state (Active or Monitor). To alert you to this condition, the ⚠ Warning icon will be displayed. The 📶 Antenna icon and current air temperature (TWRFS-I only) will be flashing and the signal bar indicator will be cleared. See Figure 25.

If communication is not restored within 48 hours, the sensor system will automatically revert to the Monitor mode; allowing automatic irrigation to resume as scheduled. The ⚠ Warning and 📶 Antenna icons will continue to flash. On the TWRFS-I model, the temperature is replaced with two dashes. The 🚰 Water Conservation indicators will flash in unison. See Figure 26.

## Prolonged Active Mode

If the sensor system remains in the Active mode for seven consecutive days, it will revert to the Monitor mode, allowing the irrigation system to resume automatic operation.

The 💧 Sensor Status indicator will flash continuously and the ⚠ Warning icon will be displayed to alert you to this condition. See Figure 27.



**Note:** A prolonged Active mode generally indicates a stuck sensor.

Check the sensor test spindle to confirm that it moves freely when the sensor discs are dry.

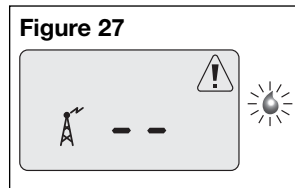
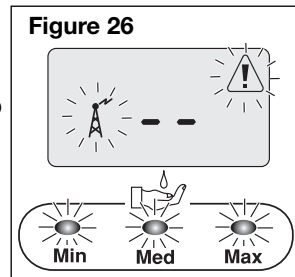
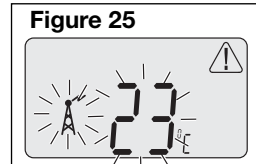
- To reset the receiver, press the 🗑️ → **Smart Bypass** button one time.







## Turn the Receiver Module Off and On

1. To turn the receiver module **Off**, press and hold the  Adjust button until two dashes are displayed (approximately 5 seconds), then release.
2. To turn the receiver **On**, press the  Setup button **two times**. The receiver will return to the normal display mode within approximately 10 seconds.

## Set or Restore the Sensor Address Code

The receiver and sensor modules are factory-matched to communicate using a specific address code. If you have purchased a new sensor module or if it becomes necessary to reset the address code, use the following procedure to enable communication:

1. Press and hold the  **Smart Bypass** button until all three  Water Conservation indicators are illuminated and the  Setup icon begins blinking (approximately 15 seconds). See Figure 28.
2. Activate the sensor module at close range by pressing the test spindle until the  Sensor Status indicator is illuminated, then release the test spindle. Refer to step 3 of “Initial System Test” on page 8 for additional information.

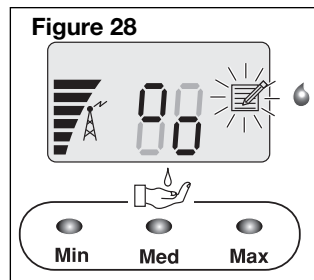

**Note:** If the Water Conservation level is set to Medium or Maximum, or the Dry Out feature is in use, the sensor system will be activated. Press the  **Smart Bypass** button to reset the receiver to the Monitor mode.

## Sensor Module Battery Replacement

1. Unscrew and remove the bottom cap from the sensor housing.
2. Grasping the edges of the circuit board assembly, carefully slide the circuit board assembly out of the housing.
3. Remove the battery cover and batteries.
4. Insert two new 3V CR2032 (or equivalent) batteries with the positive (+) side facing toward the retaining clip.

**Note:** Properly dispose of the used batteries according to the battery manufacturer's recommendations.

5. Install the battery cover.
6. Align the circuit board assembly with the housing guide slots and carefully insert it into the housing. The circuit board will fit only when oriented properly. The bottom edge of the circuit board and housing will be even when fully inserted.
7. Thread the antenna wire through the hole in bottom cap. Screw the cap onto the housing and tighten by hand.

Figure 29

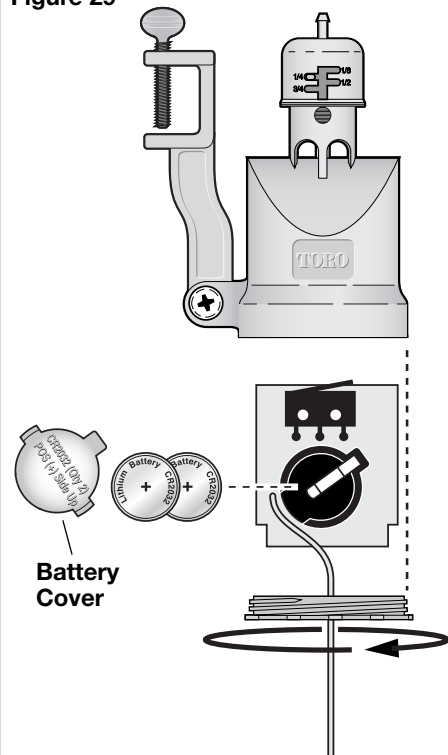

## Troubleshooting

If you encounter problems at any point in the installation process, or the components do not function properly, try the Troubleshooting procedures first. If the problem is not listed or the remedy does not resolve the problem, contact your local Toro irrigation distributor for assistance.

### **Signal strength is weak or inconsistent.**

The Wireless Rain Sensor system has a maximum operating range of 152.4m (500') LOS (Line-of-Site). Operating range is based on optimum site conditions with no signal interference present. But in most cases there are buildings in the way or other sources of radio signal interference, that can reduce the signal range. Most residential and small commercial buildings will not pose reception problems under normal conditions. However, there are some sites with buildings or structures constructed of thick, dense walls, or contain electrical equipment that emits high levels of radio frequency interference. If you are having difficulty obtaining good signal strength, try the following possible solutions:

- Move the antenna away from any large metal object.
- Avoid indoor receiver locations where cellular or cordless phones have trouble with reception.
- Mount the sensor and receiver modules closer together if possible.
- If the sensor is installed directly over the receiver, move the sensor slightly to either side of the receiver.



**The receiver display is blank.**

- Check the 24 Vac power connections. The red power wires from the receiver must be connected to the controller's 24 Vac power source. Make sure the power wires are not connected to the station or pump/master valve terminals. These terminals only provide 24 Vac power when the controller is operating the sprinkler zones.

**The sensor module does not activate the receiver at close range.**

- The receiver module may not recognize the sensor module address code. See "Set or Restore Sensor Address Code" on page 20.
- Remove and replace the sensor module batteries.

**The sensor system works, but the controller does not respond to the sensor.**

- Check the Yellow or Brown wire connection. The **Brown** wire must be used for **Normally Closed** (NC) controller operation and **Yellow** wire for **Normally Open** (NO) operation.
- The **Brown** wire must be used when **splicing** into the valve **common wire**.
- Make sure the controller's Sensor control switch is **not** in the Bypass or Off position.

## Specifications

Models: TWRS-I (Wireless Rain Sensor-International) and TWRFS-I (Wireless Rain/Freeze Sensor-International)

Wireless Communication Range: Up to 152.4m LOS (line-of-site)

Sensor Type: Industry-standard hygroscopic disc stack with adjustable rainfall sensitivity

Sensor Module Batteries: (2) 3V cells - CR2032 (or equivalent)

Average Battery Life: 5 years

Operating Temperature Range: -29°C to 49°C

Receiver Power: 22–28 Vac/Vdc, 100mA (from controller w/Class 2, UL-approved transformer)

Relay Contacts Output: Normally Open (NO) and Normally Closed (NC) 3A at 24 Vac

**Note:** The Toro Wireless Rain and Rain/Freeze Sensor series, models TWRS, TWRS-I, TWRFS and TWRFS-I, are patented with the following U.S. patents pending: 6,452,499, 5,101,083 and D489,280.

## **The Toro Promise – Five-year Limited Warranty**

The Toro Company and its affiliate, Toro Warranty Company, pursuant to an agreement between them, jointly warrants, to the owner, each new piece of equipment (featured in the current catalog at date of installation) against defects in material and workmanship for a period described below, provided they are used for irrigation purposes under manufacturer's recommended specifications. Product failures due to acts of God (i.e., lightning, flooding, etc.) are not covered by this warranty.

Neither Toro nor Toro Warranty Company is liable for failure of products not manufactured by them even though such products may be sold or used in conjunction with Toro products.

During such warranty period, we will repair or replace, at our option, any part found to be defective. Your remedy is limited solely to the replacement or repair of defective parts.

Return the defective part to your local Toro distributor, who may be listed in your telephone directory Yellow Pages under "Irrigation Supplies" or "Sprinkler Systems," or contact The Toro Warranty Company P.O. Box 489, Riverside, California, 92502. For the location of your nearest Toro distributor outside the U.S., call (951) 688-9221.

This warranty does not apply where equipment is used, or installation is performed in any manner contrary to Toro's specifications and instructions, nor where equipment is altered or modified.

Neither Toro nor Toro Warranty Company is liable for indirect, incidental or consequential damages in connection with the use of equipment, including but not limited to: vegetation loss, the cost of substitute equipment or services required during periods of malfunction or resulting non-use, property damage or personal injury resulting from installer's actions, whether negligent or otherwise.

Some states do not allow the exclusion or limitation of incidental or consequential damages, so the above limitation or exclusion may not apply to you.

All implied warranties, including those of merchantability and fitness for use, are limited to the duration of this express warranty.

Some states do not allow limitations of how long an implied warranty lasts, so the above limitation may not apply to you.

This warranty gives you specific legal rights and you may have other rights which vary from state to state.

The Toro Wireless Rain Sensor series is covered by this warranty for a period of five years from the date of installation.

## **Electromagnetic Compatibility**

The TWRS-I and TWRFS-I wireless rain sensor series is CISPR 22 class B compliant.

FCC ID: OF7TWRS

**IC: 3575A-TWRS**

**⚠ Important:** Changes or modifications to this unit, not expressly approved by the party responsible for compliance, could void the authority to operate the equipment.