

WS-9004U  
915MHz  
WIRELESS RAIN GAUGE

*INSTRUCTION MANUAL*

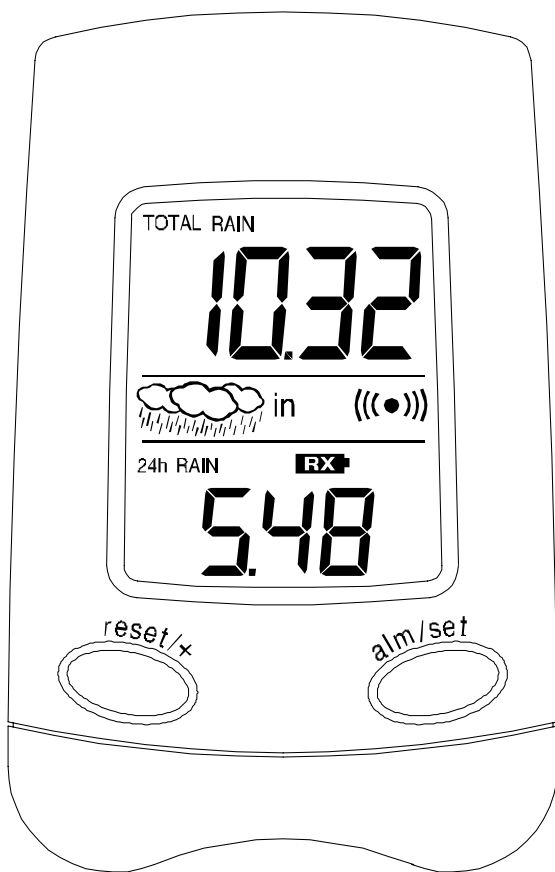

Tomorrow's Weather Today™

# *CONTENTS*

---

03	introduction
03	features
04	setting up
06	function keys
07	operations
08	maintenance
09	specifications
09	liability disclaimer
10	warranty information

# INTRODUCTION

Thank You and Congratulations on your purchase of this innovative Wireless Rain Gauge for display of rainfall data through a wireless rainfall sensor. With 2 easy to use function keys, this unique product is perfect for gardeners and weather buffs alike.

This product offers:



**INSTANT TRANSMISSION** is the state-of-the-art new wireless transmission technology, exclusively designed and developed by LA CROSSE TECHNOLOGY. **INSTANT TRANSMISSION** offers you an immediate update (every 6 seconds!) of all your outdoor data measured from the transmitters: follow your climatic variations in real-time!

## Wireless Rain Gauge (Receiver)

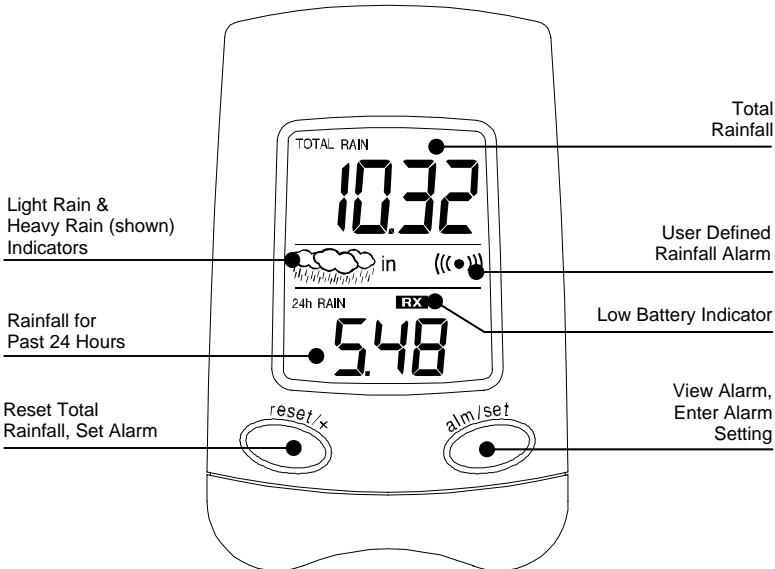

## FEATURES

- 915 MHz Instant Data Transfer: Updates every 6 seconds
- Rainfall for Last 24 Hours
- User Defined Alarm for the past 24H Rainfall
- Current Rainfall Indicator, Light Rain & Heavy Rain Indicators
- Low Battery Indicator for Both Receiver & Rain Sensor
- Wall Hanging or Free Standing

## SETTING UP

**Hint:** Use good quality Alkaline Batteries; avoid rechargeable batteries.

1. Have the receiver and the rain gauge 3 to 5 feet apart.
2. Place the batteries into the **rain gauge FIRST** and next into the receiver. Observing the correct polarization, insert 2 "AAA" Alkaline Batteries into the compartment at the back of the rain gauge and replace the cover. Follow the same guidelines for the receiver.

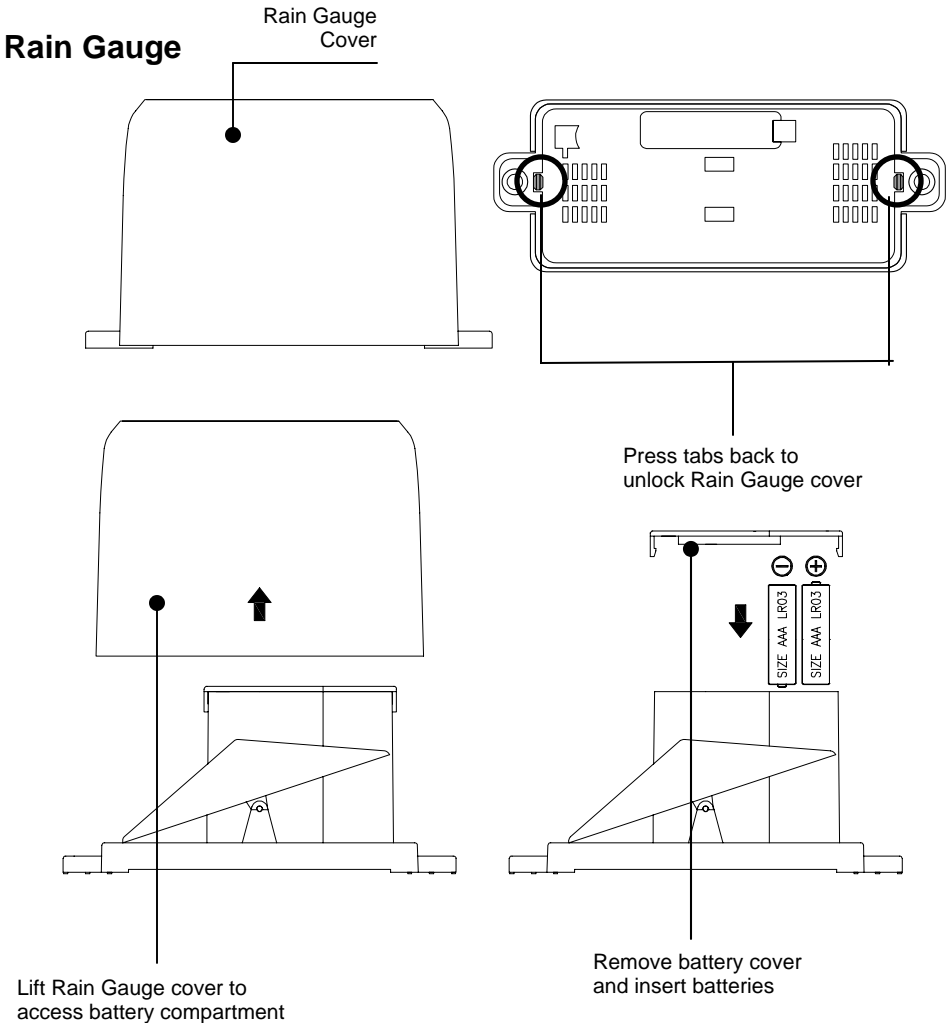

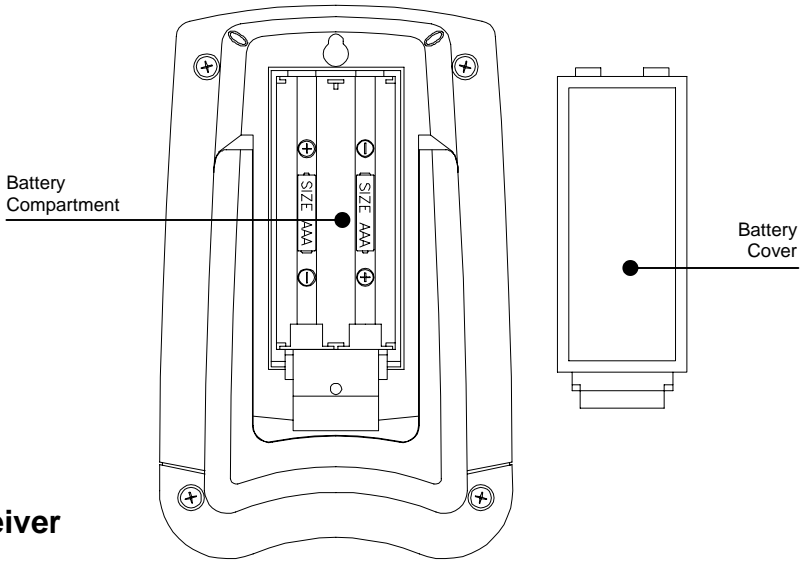

## Receiver

3. **DO NOT PRESS ANY BUTTONS FOR 15 MINUTES.**
4. All segments of the LCD will light up briefly. Then 0.00 inch will be displayed in both sections of the LCD. If the “0.00” is not displayed after a few seconds, remove the batteries and wait for at least 10 seconds before reinserting them.
5. Place the rain gauge in an appropriate location. The rain gauge should be placed in a secure and flat location where it can properly collect properly rain quantity without obstruction. The rain gauge has a range of 330 feet. Keep in mind that the 330 feet is in open air with no obstructions and that radio waves **DO NOT** curve to go around objects. Real-world transmission range will vary depending on what is in the path of the signal. Each obstruction (roof, walls, floors, ceilings, thick trees, etc.) will effectively cut signal range in half.

**Example:** A wireless rain gauge receiver with a 330 feet range is mounted on an interior wall, so that the signal has to pass through one interior wall, one exterior wall, and across the 10 feet width of the room between the 2 walls. The first wall will reduce the range to 165 feet, and the second wall will reduce the range to 87 feet. Factoring in the 10 foot room, this leaves a maximum of 77 feet of remaining signal range.

This allowance is typically enough for a frame wall with non-metallic siding; however certain materials can reduce range even further. Metal siding, stucco, and some types of glass can reduce signal range by as much as  $\frac{3}{4}$  or more, compared to the  $\frac{1}{2}$  reduction typical of most obstructions. It is possible to receive a signal through these materials, however maximum range will be much less due to their tendency to absorb or reflect a much larger portion of the sensor's signal.

**Note:**

When opening the battery cover make sure that the batteries do not spring free from the contacts since this will cause start and transmission problems.

**Battery Change:**

It is recommended to replace the batteries in the unit approximately every 3 years to ensure optimum accuracy.

*FUNCTION KEYS*

The simple design of this product features 2 keys.

**RESET/+ Key:**

- Press for 5 seconds to reset the TOTAL rainfall data "0".
- Press and release to advance the value for the alarm.

**ALM/SET:**

- Press and release to activate/deactivate alarm
- Press for 5 seconds to enter alarm setting

*OPERATIONS*

**Setting the Alarm**

- Press and hold the **ALM/SET** button until the alarm is flashing on the bottom screen.
- Advance the alarm value by pressing and releasing the **RESET/+** button.
- Alarm can be set in 0.05" increments from 0.05" to 4.00"
- The icon **((•))** will appear when the alarm is turned ON.
- Press and release **ALM/SET** button to turn the alarm off.

- To view the alarm pres and hold the **ALM/SET** button. This will cause the receiver to beep if the set alarm value has already been reached.

### Resetting TOTAL RAINFALL and 24 HOUR RAINFALL

- **Total Rainfall:** Press and hold the **RESET/+** button. The receiver will beep, and the total rainfall will reset to "0.00".
- **24 Hour Rainfall:** To reset the 24 Hour Rainfall to "0.00", remove the batteries, wait 2 minutes, and then re-insert the batteries.

**Note:** The 24H Rainfall will not reset to "0.00". Instead the value will update every hour.  
The 24H Rainfall will only show "0.00" if there is no rainfall for a full period of 24 hours.

### Light Rain/Heavy Rain Indicator

The wireless rain gauge features 2 rain level indicators: Light Rain and Heavy Rain.

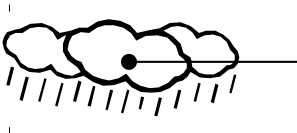

**Light Rain:** Indicated by 3 clouds and rain with no animation.  
The **Light Rain** icon will appear if any rain is registered over the past 10 minutes.

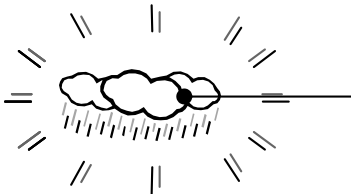

**Heavy Rain:** Indicated by 3 clouds with animated rain.  
The **Heavy Rain** Icon will appear if more than 10 counts (0.2") have been registered over the past 10 minutes.

### Low Battery Indicators (RX & TX)

- **RX:** Indicates the receiver battery is low.
- **TX:** Indicates the rain gauge battery is low.

### MOUNTING

#### Positioning the Receiver:

The Receiver can be positioned on a flat surface or on a wall.

## Foldout Table Stand

The foldout table stand is located on the backside of the Receiver. Carefully pull out the stand and place the Receiver in the desired location.

## Wall Mounting

Place a screw in the desired location leaving the head extended about  $\frac{1}{4}$ " from the wall. Hang the Receiver on the screw ensuring that the Receiver locks into place.

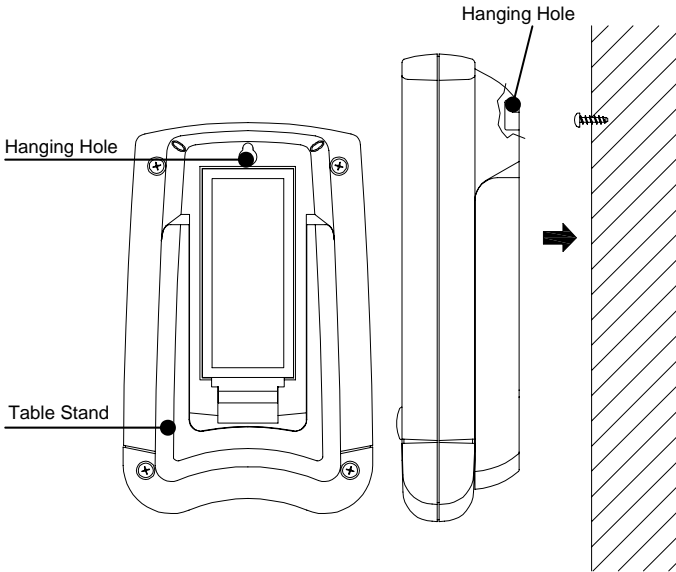

## Positioning the Rain Gauge

Position the connected rain gauge outdoor to collect rainfall data. Ensure that the rain gauge is placed in a secure and flat location where it can properly collect properly rain quantity without obstruction. Ensure also that the rain gauge is securely mounted at the appropriate location otherwise it may not transmit accurate rainfall data.

The rain gauge must be level to transmit correct readings. It is recommended to mount the rain gauge 3 feet or higher off of the ground. Screw the rain gauge down snugly in the holes provided (but not too tight as this will affect the accuracy of the gauge).



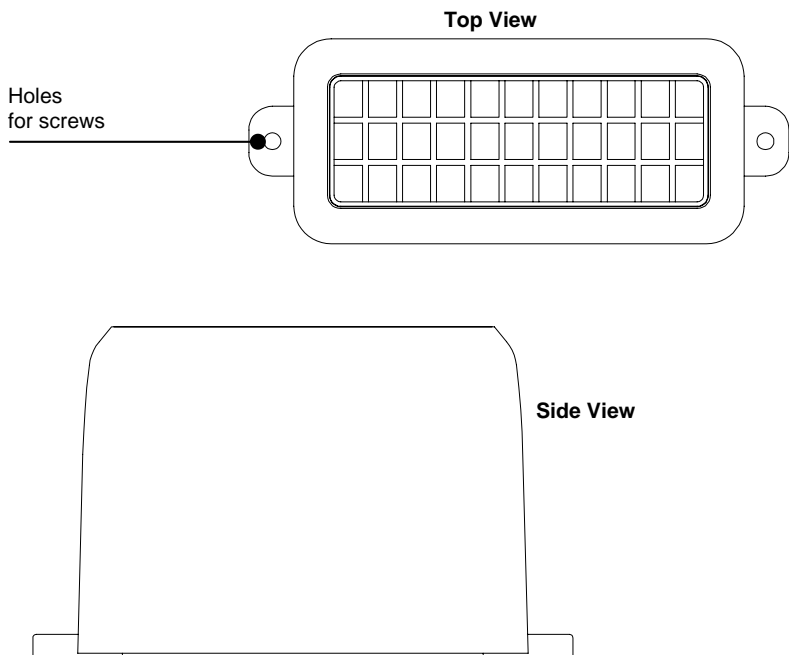

## ***MAINTENANCE***

- Avoid placing the units in locations prone to extreme temperatures, vibration and shock since these may cause damage and inaccurate readings.
- When cleaning the display and casing of the Wireless Rain Gauge, use a soft damp cloth only. Do not use solvents or scouring agents as they may mark the casing and LCD.
- Do not submerge the Wireless Rain Gauge in water.
- Immediately remove all low powered batteries to avoid leakage and damage. Replace only with new batteries of the recommended type.
- Please do not make any attempt to make any repairs to the units. Return them to their original point of purchase for repair by qualified personnel. Opening and tampering with the units will invalidate the warranty.

## **SPECIFICATIONS**

<b>Rainfall</b>	
<b>Rainfall Alarm</b>	User defined from 0.05" to 4.00" over 24 hour period
<b>Rainfall Range</b>	0.00" to 199.99" (total)
<b>Unit Display</b>	Inch
<b>Transmission Range</b>	330 Feet
<b>Transmission</b>	915 MHz, updating every 6 seconds

<b>Power Supply:</b>	
<b>Receiver:</b>	2 x AAA, IEC LR3, 1.5V.
<b>Rain Gauge:</b>	2 x AAA, IEC LR3, 1.5V.
<b>Battery life cycle:</b>	Approximately 36 months.
<b>Recommended battery type:</b>	Alkaline.

<b>Dimensions (H x L x W)</b>	
<b>Receiver</b>	3.85" x 2.45" x .95"
<b>Rain Gauge:</b>	5.67" x 2.15" x 3.46"

## **LIABILITY DISCLAIMER**

- The manufacturer and supplier cannot accept any responsibility for any incorrect readings and any consequences occurring should an inaccurate reading take place.
- This product is not to be used for medical purposes or for public information.
- This product is designed for strict home use as an indication of rain quantities and is not 100% accurate. Readouts given by this product should be taken only as an indication and not as being totally accurate.
- The specifications of this product may change without prior notice.
- This product is not a toy. Keep out of the reach of children.
- No part of this manual may be reproduced without written consent of the manufacturer.

## **WARRANTY INFORMATION**

La Crosse Technology, Ltd provides a 1-year limited warranty on this product against manufacturing defects in materials and workmanship.

This limited warranty begins on the original date of purchase, is valid only on products purchased and used in North America and only to the original purchaser of this product. To receive warranty service, the purchaser must contact La Crosse Technology, Ltd for problem determination and service procedures. Warranty service can only be performed by a La Crosse Technology, Ltd authorized service center. The original dated bill of sale must be presented upon request as proof of purchase to La Crosse Technology, Ltd or La Crosse Technology, Ltd's authorized service center.

La Crosse Technology, Ltd will repair or replace this product, at our option and at no charge as stipulated herein, with new or reconditioned parts or products if found to be defective during the limited warranty period specified above. All replaced parts and products become the property of La Crosse Technology, Ltd and must be returned to La Crosse Technology, Ltd. Replacement parts and products assume the remaining original warranty, or ninety (90) days, whichever is longer. La Crosse Technology, Ltd will pay all expenses for labor and materials for all repairs covered by this warranty. If necessary repairs are not covered by this warranty, or if a product is examined which is not in need or repair, you will be charged for the repairs or examination. The owner must pay any shipping charges incurred in getting your La Crosse Technology, Ltd product to a La Crosse Technology, Ltd authorized service center. La Crosse Technology, Ltd will pay ground return shipping charges to the owner of the product to a USA address only.

Your La Crosse Technology, Ltd warranty covers all defects in material and workmanship with the following specified exceptions: (1) damage caused by accident, unreasonable use or neglect (including the lack of reasonable and necessary maintenance); (2) damage occurring during shipment (claims must be presented to the carrier); (3) damage to, or deterioration of, any accessory or decorative surface; (4) damage resulting from failure to follow instructions contained in your owner's manual; (5) damage resulting from the performance of repairs or alterations by someone other than an authorized La Crosse Technology, Ltd authorized service center; (6) units used for other than home use (7) applications and uses that this product was not intended or (8) the products inability to receive a signal due to any source of interference.. This warranty covers only actual defects within the product itself, and does not cover the cost of installation or removal from a fixed installation, normal set-up or adjustments, claims based on misrepresentation by the seller or performance variations resulting from installation-related circumstances.

**LA CROSSE TECHNOLOGY, LTD WILL NOT ASSUME LIABILITY FOR INCIDENTAL, CONSEQUENTIAL, PUNITIVE, OR OTHER SIMILAR DAMAGES ASSOCIATED WITH THE OPERATION OR MALFUNCTION OF THIS PRODUCT. THIS PRODUCT IS NOT TO BE USED FOR MEDICAL PURPOSES OR FOR PUBLIC INFORMATION. THIS PRODUCT IS NOT A TOY. KEEP OUT OF CHILDREN'S REACH.**

This warranty gives you specific legal rights. You may also have other rights specific to your State. Some States do not allow the exclusion of consequential or incidental damages therefore the above exclusion of limitation may not apply to you.

For warranty work, technical support, or information contact:

La Crosse Technology, Ltd  
190 Main Street  
La Crescent, MN 55947  
Phone: 507.895.7095  
Fax: 507.895.2820

e-mail:

[support@lacrossetechnology.com](mailto:support@lacrossetechnology.com)  
(warranty work)

[sales@lacrossetechnology.com](mailto:sales@lacrossetechnology.com)  
(information on other products)

web:  
[www.lacrossetechnology.com](http://www.lacrossetechnology.com)

**Questions? Please see:  
[www.lacrossetechnology.com/9004](http://www.lacrossetechnology.com/9004)**

All rights reserved. This handbook must not be reproduced in any form, even in excerpts, or duplicated or processed using electronic, mechanical or chemical procedures without written permission of the publisher.

This handbook may contain mistakes and printing errors. The information in this handbook is regularly checked and corrections made in the next issue. We accept no liability for technical mistakes or printing errors, or their consequences.

All trademarks and patents are acknowledged.