

HITACHI PROGRAMMABLE CONTROLLER

HIDIC EH-150

**RESISTANCE TEMPERATURE DETECTIVE
INPUT MODULE(EH-PT4)
APPLICATION MANUAL**

WARNING

To ensure that the equipment described by this manual. As well as all equipment connected to and used with it, operate satisfactorily and safety, all applicable local and national codes that apply to installing and operating the equipment must be followed. Since codes can vary geographically and can change with time, it is the user's responsibility to determine which standard and codes apply, and to comply with them.

FAILURE TO COMPLY WITH APPLICABLE CODES AND STANDARDS CAN RESULT IN DAMAGE TO EQUIPMENT AND/OR SERIOUS INJURY TO PERSONNEL.

INSTALL EMERGENCY POWER STOP SWITCH, WHICH OPERATES INDEPENDENTLY OF THE PROGRAMMABLE CONTROLLER TO PROTECT THE EQUIPMENT AND/OR PERSONNEL IN CASE OF THE CONTROLLER MALFUNCTION.

Personnel who are to install and operate the equipment should carefully study this manual and any other referred to by it prior to installation and/or operation of the equipment. Hitachi Industrial Equipment Systems Co., Ltd. constantly strives to improve its products, and the equipment and the manual(s) that describe it may be different from those already in your possession.

If you have any questions regarding the installation and operation of the equipment, or if more information is desired, contact your local Authorized Distributor or Hitachi Industrial Equipment Systems Co., Ltd.

IMPORTANT

THIS EQUIPMENT GENERATES, USES, AND CAN RADIATE RADIO FREQUENCY ENERGY AND, IF NOT INSTALLED AND USED IN ACCORDANCE WITH THE INSTRUCTION MANUAL, MAY CAUSE INTERFERENCE TO RADIO COMMUNICATIONS. AS TEMPORARILY PERMITTED BY REGULATION, IT HAS NOT BEEN TESTED FOR COMPLIANCE WITH THE LIMITS FOR CLASS A COMPUTING DEVICES PURSUANT TO SUBPART J OF PART 15 OF FCC ROULES, WHICH ARE DESIGNED TO PROVIDE REASONABLE PROTECTION AGAINST SUCH INTERFERENCE.

OPERATION OF THIS EQUIPMENT IN A RESIDENTIAL AREA IS LIKELY TO CAUSE INTERFERENCE IN WHICH CASE THE USER, AT HIS OWN EXPENSE, WILL BE REQUIRED TO TAKE WHATEVER MEASURES MAY BE REQUIRED TO CORRECT THE INTERFERENCE.

LIMITED WARRANTY AND IMITATION OF LIABILITY

Hitachi Industrial Equipment Systems Co., Ltd. (Hitachi) warrants to the original purchaser that the programmable logic controller (PLC) manufactured by Hitachi is free from defects in material and workmanship under normal use and service. The obligation of Hitachi under this warranty shall be limited to the repair or exchange of any part or parts which may prove defective under normal use and service within eighteen (18) months from the date of manufacture or twelve (12) months from the date of installation by the original purchaser which ever occurs first, such defect to be disclosed to the satisfaction of Hitachi after examination by Hitachi of the allegedly defective part or parts. This warranty is expressly in lieu of all other warranties expressed or implied including the warranties of merchantability and fitness for use and of all other obligations or liabilities and Hitachi neither assumes, nor authorizes any other person to assume for Hitachi, any other liability in connection with the sale of this PLC. This warranty shall not apply to this PLC or any part hereof which has been subject to accident, negligence, alternation, abuse, or misuse. Hitachi makes no warranty whatsoever in respect to accessories or parts not supplied by Hitachi. The term "original purchaser", as used in this warranty, shall be deemed to mean that person for whom the PLC is originally installed.

In no event, whether as a result of breach of contract, warranty, tort (including negligence) or otherwise, shall Hitachi or its suppliers be liable for any special, consequential, incidental or penal damages including but not limited to, loss or profit or revenues, loss of use of the products or any associated equipment, damage to associated equipment, cost of capital, cost of substitute products, facilities, services or replacement power, down time costs, or claims of original purchaser's customers for such damages.

To obtain warranty service, return the product to your distributor, or send it with a description of the problem, proof of purchase, post paid, insured, and in a suitable package to:

Quality Assurance Dept.
Hitachi Industrial Equipment Systems Co., Ltd.
46-1 Ooaza-Tomioka Nakajo-machi
Kitakanbara-gun, Niigata-ken
959-2608 JAPAN

Copyright 2002 by Hitachi Industrial Equipment Systems Co., Ltd.
All Right Reserved – Printed in Japan

The Information and/or drawing set forth in this document and all right in and to inventions disclosed herein and patent which might be granted thereon disclosing or employing and the materials, methods, techniques or apparatus described herein are the exclusive property of Hitachi Industrial Equipment Systems Co., Ltd .

No copies of the information or drawings shall be made without the prior constant of Hitachi Industrial Equipment Systems Co., Ltd.

Hitachi Industrial Equipment Systems Co., Ltd. provides customer assistance in varied technical areas. Since Hitachi does not possess full access to data concerning all of the uses and applications of customer's products, responsibility is assumed by Hitachi neither for customer product design nor for any infringement of patents or rights of others, which may result from Hitachi assistance.

The specifications and descriptions contained in this manual were accurate at the time they were approved for printing. Since Hitachi Industrial Equipment Systems Co., Ltd. Incorporated constantly strives to improve all its products, we reserve the right to make changes to equipment and/or manual at any time without notice and without incurring any obligation other than as noted in this manual.

Hitachi Industrial Equipment Systems Co., Ltd. assumes no responsibility for errors that may appear in this manual.

As the product works with user program, and Hitachi Industrial Equipment Systems Co., Ltd. cannot test all combination of user program components, it is assumed that a bug or bugs may happen unintentionally. If it is happened: please inform the fact to Hitachi Industrial Equipment Systems Co., Ltd. or its representative. Hitachi will try to find the reason as much as possible and inform the countermeasure when obtained.

Nevertheless Hitachi Industrial Equipment Systems Co., Ltd. intends to make products with enough reliability, the product has possibility to be damaged at any time. Therefore personnel who are to install and operate the equipment have to prepare with the countermeasure such as power off switch can be operated independently of the controller. Otherwise, it can result in damage to equipment and/or serious injury to personnel.

Safety Precautions

Read this manual and related documents thoroughly before installing, operating, performing preventive maintenance or performing inspection, and be sure to use the unit correctly. Use this product after acquiring adequate knowledge of the unit, all safety information, and all cautionary information. Also, make sure this manual enters the possession of the chief person in charge of safety maintenance.

Safety caution items are classified as "Danger" and "Caution" in this document.



: Cases where if handled incorrectly a dangerous circumstance may be created, resulting in possible death or severe injury.



: Cases where if handled incorrectly a dangerous circumstance may be created, resulting in possible minor to medium injury to the body, or only mechanical damage.

However, depending on the circumstances, items marked with  may result in major accidents.

In any case, they both contain important information, so please follow them closely.

Icons for prohibited items and required items are shown below:



: Indicates prohibited items (items that may not be performed). For example, when open flames are prohibited,  is shown.



: Indicates required items (items that must be performed). For example, when grounding must be performed,  is shown.

1. About installation

CAUTION

- Use this product in an environment as described in the catalogue and this document.
If this product is used in an environment subject to high temperature, high humidity, excessive dust, corrosive gases, vibration or shock, it may result in electric shock, fire or malfunction.
- Perform installation according to this manual.
If installation is not performed adequately, it may result in dropping, malfunction or an operational error in the unit.
- Do not allow foreign objects such as wire chips to enter the unit.
They may become the cause of fire, malfunction or failure.

2. About wiring

REQUIRED

- Always perform grounding (FE terminal).
If grounding is not performed, there is a risk of electric shocks and malfunctions.

CAUTION

- Connect power supply that meets rating.
If a power supply that does not meet rating is connected, fire may be caused.
- The wiring operation should be performed by a qualified personnel.
If wiring is performed incorrectly, it may result in fire, damage, or electric shock.

3. Precautions when using the unit

DANGER

- Do not touch the terminals while the power is on.
There is risk of electric shock.
- Structure the emergency stop circuit, interlock circuit, etc. outside the programmable controller (hereinafter referred to as PC).
Damage to the equipment or accidents may occur due to failure of the PC.
However, do not interlock the unit to external load via relay drive power supply of the relay output module.

CAUTION

- When performing program change, forced output, RUN, STOP, etc., while the unit is running, be sure to verify safety.
Damage to the equipment or accidents may occur due to operation error.
- Supply power according to the power-up order.
Damage to the equipment or accidents may occur due to malfunctions.

4. About preventive maintenance

DANGER

- Do not connect the \oplus , \ominus of the battery in reverse. Also, do not charge, disassemble, heat, place in fire, or short circuit the battery.
There is a risk of explosion or fire.

PROHIBITED

- Do not disassemble or modify the unit.
These actions may result in fire or malfunction.

CAUTION

- Turn off the power supply before removing or attaching module/unit.
Electric shock, malfunction or failure may result.

Revision

No.	Content	Date	Manual No.

Table of contents

1. Introduction	1-1 to 1-4
1.1 Before Use	1-2
1.2 Precaution on Use	1-3
1.3 Features	1-3
1.4 Principle of Operation	1-4
2. Structure and Nameplate	2-1
2.1 Structure and Name of Each Part	2-1
3. Specification	3-1 to 3-2
3.1 Specification list	3-1
3.2 Terminal layout and internal circuit	3-2
4. Block Diagram	4-1
4.1 Internal Block Diagram	4-1
5. External Wiring	5-1
5.1 Resistance Temperature Detective Connection Method and External Wiring	5-1
6. Setting	6-1
6.1 Setting of Temperature Range	6-1
7. Collection of Temperature Data	7-1 to 7-7
7.1 I/O Allocation	7-1
7.2 Temperature Data	7-2
7.3 Example of Calculation	7-4
7.4 Correspondence Table between Temperature and Temperature Data	7-5
8. Error Detection Processing	8-1 to 8-2
8.1 Measured Temperature Range Over	8-1
8.2 Treatment for Sudden Change of Temperature Conversion Data	8-2
9. Mounting	9-1 to 9-2
9.1 Installation	9-1
9.2 Mounting Method	9-1
9.3 Maintenance and Inspection	9-1
9.4 Precautions on External Wiring	9-2

10. Example of Programming	10-1 to 10-4
-----------------------------------	---------------------

- 10.1 Example of Programming 1 10-1
- 10.2 Example of Programming 2 (Offset adjustment) 10-4

11. Troubleshooting	11-1
----------------------------	-------------

- 11.1 The Allocation Error "41" is indicated in CPU 11-1
- 11.2 Data Error in a Specific Channel 11-1
- 11.3 Data Error in All Channels 11-1

12. Appendix	12-1
---------------------	-------------

- 12.1 Calculation of External Wiring Resistance 12-1

1. Introduction

This manual describes how to operate the EH-PT4 (Resistance Temperature Detective input module) properly, which is one of the special function module of EH-150 Programmable Logic controller(PLC). Carefully read this manual to familiarize yourself with the procedures respectively of installation, operation, and maintenance and inspection.

Please be sure to read the related application manuals, too.

Table 1.1 Reference Manual list

No.	Document	Manual No.
1	About the detailed operation method of the programming unit 1) Instruction word programmer (PGM-CHH) Instruction word programmer manual 2) Portable indication programmer (PGM-GPH) Portable indication programmer manual 3) LADDER EDITOR FOR WINDOWS (HLW-PC3) Programming manual 4) LADDER EDITOR FOR DOS (HL-AT3E) Programming manual	NB981X* NB982X* NJI-206X* NB335X*
2	EH-150 APPLICATION MANUAL	NJI-280X*

“*” means revision of manual and up to A, B, C in order.

Reference

What is Resistance Temperature Detective(RTD)?

This is also called as “Resistance Thermometer Sensor”.

Refers to the device measuring the temperature by using the metal’s property that its electric resistance changes with the temperature and is often made of Pt 100 ohm (platinum with a resistance of 100 ohm at 0 °C).

As for the principle of the measurement, by feeding a constant current of 1 through 5 mA (2 mA in this module) to a resistance temperature detective, the change of resistance due to that of temperature is measured as the change of voltage.



Use a resistance temperature detective complying with IEC 751 for this module.

1.1 Before Use

The resistance temperature detective input module (hereafter EH-PT4) has been carefully manufactured, but you are kindly advised to make the following checks on receipt of it.

- (1) The type and specification of the module are as specified by the order.
- (2) No damage is caused to the equipment during transport. If any failures are found, contact the sales office.
- (3) The accessories listed in Table 1.2 are supplied.

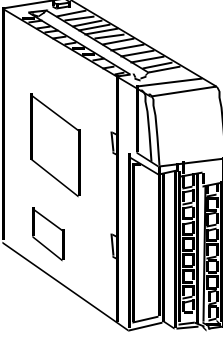
Table 1.2 Package contents list of resistance temperature detective input module

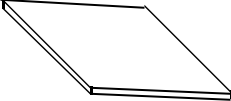
No.	Contents	Quantity	Remarks
1	Resistance temperature detective input module body	1	
2	I/O cover	1	
3	Operation manual	1	

1.2 Precautions on Use

- (1) Before the installation and removal of the module, turn off the power.
- (2) Before the connection of the external wiring and removal of the terminal board, turn off the power.
- (3) The terminal board handles fine signals. Therefore upon handling the module or wiring, be careful not to apply a voltage on it by mistake or leave it under the influence by excessive static electricity.
- (4) Upon the connection of external wiring, before work, eliminate static electricity by touching a grounded metal bar to prevent it from being damaged by excessive static electricity charged on the human body. To prevent a malfunction due to static electricity do not touch the terminal during power feeding.
- (5) When the connection cable to a resistance temperature detective is cut, the temperature conversion data becomes abnormal. If the temperature data exceeds the normal range to protect the external devices, adjust the control system so that the external devices operate with safety.
- (6) If the resistance of a resistance temperature detective (RTD) exceeds 250 ohm (corresponding to about 410 °C) at PT100, or 2500 ohm(corresponding to about 410 °C) at PT1000, except when the line is broken, the temperature conversion data is unstable.

1.3 Features

- (1) EH-PT4 applies for two kinds of platinum resistance temperature detectives: Pt100(IEC 751) and Pt1000.
- (2) Temperature measurement range: Three kinds of ranges(selected by switch)

Resistance temperature detectives	Temperature measurement range(°C)	Accuracy(°C)
Pt100	-50 to + 400	± 3
Pt100	-20 to + 40	± 0.5
Pt1000	-50 to + 400	± 6

- (3) Because the accuracy of the temperature measurement range -20 to +40°C is ± 0.5 °C, EH-PT4 is suitable for exact measurement.
- (4) Temperature conversion data: signed 15 bits.
- (5) Number of Inputs: 4 channels, 3-wire system.

2. Structure and Nameplate

2.1 Structure and Name of Each Part

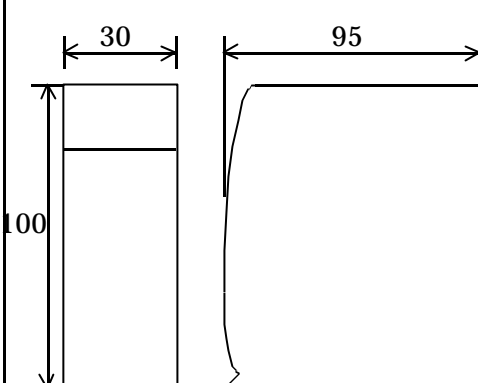
Name and function of each part	Type	EH-PT4
	Weight	Approx. 180 g
	Dimensions(mm)	

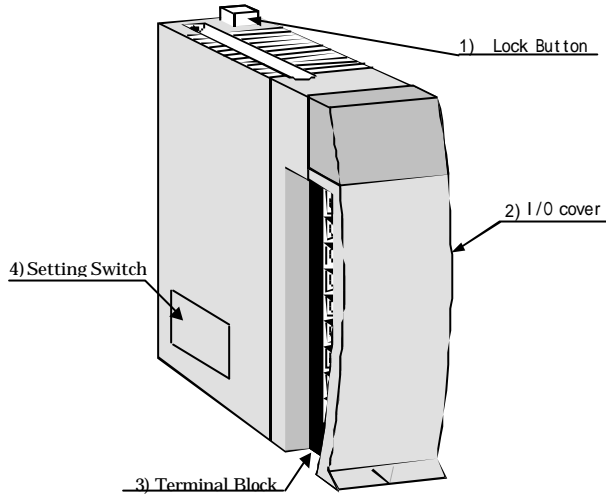

No.	Name	Function	Remarks
1)	Lock button	This is used when removing the module from the base unit. After it is installed to the base unit, the fixation can be reinforced using screws. In this case, use M4x10mm screws.	
2)	I/O cover	This is the cover attached to the terminal block area.	
3)	Terminal block	This is the terminal block for connecting input signals. The terminal block can be connected or disconnected.	
4)	Setting Switch	This is used for setting of temperature range.	Refer chapter 6.

Item	Detailed explanation	Remarks
Operation explanation	The module receives input signals from outside. While the module energized, The CPU module recognizes the status of the loaded module and when it matches the I/O assignment information included in the user program. Input information is received according to the contents of the user program.	
Terminal block	The screws for the terminal block are M3 screws. Use a crimp terminal that fits the screw diameter. The maximum thickness of the cable should be only up to 0.75 SQ. The recommended crimp terminal is indicated below.	

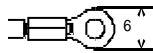

単位 : mm Unit: mm

3. Specification

3.1 Specification list

Table 3.1 shows the specifications of EH-PT4.

Table 3.1 Specification

Item		Specification
Type		EH-PT4
Resistance temperature detective		Platinum resistance temperature detective Pt100 (IEC 751) Platinum resistance temperature detective Pt1000
Temperature conversion data		Signed 15 bits (In normal state the lowest bit is always "0".)
Accuracy (Note 1)	-20 to + 40 °C (Pt100)	± 0.5 °C
	-50 to + 400 °C (Pt100)	± 3 °C
	-50 to + 400 °C (Pt1000)	± 6 °C
Temperature measurement range		-20 to +40 °C / -50 to +400 °C (2mA constant current method)
Number of channels		4 channels
Conversion time		About 1s / 4 channels
Insulation	Between channel and PC	Photocoupler insulation
	Between channels	Non-insulation
External power supply		24V DC ±10% 100mA max.
Internal current consumption (5 V DC)		200mA max.
External wiring resistance		400 ohm max. / channel
External wiring		Shielded wire
Additional function		Linearization
Error detection		
-20 to +40 °C (Pt100)		H7FFF is outputted at -25 °C or less, or at +45 °C or higher
-50 to +400 °C (Pt100/ Pt1000)		H7FFF is outputted at -60 °C or less, or at +410 °C or higher
Processing for disconnection (Note 2)		H7FFF is outputted to channel.

Note 1: The accuracy is the value when 10 minutes pass after the start of power feeding. Just after power is fed, the value may increase slightly. Because a resistance temperature detective has an error, confirm it beforehand.

Note 2: This is the case when the current terminal wiring is broken. In case the voltage terminal wiring is broken, the data becomes unspecified. ("H" of "H7FFF" means the following data is hexadecimal.)

3.2 Terminal layout and internal circuit

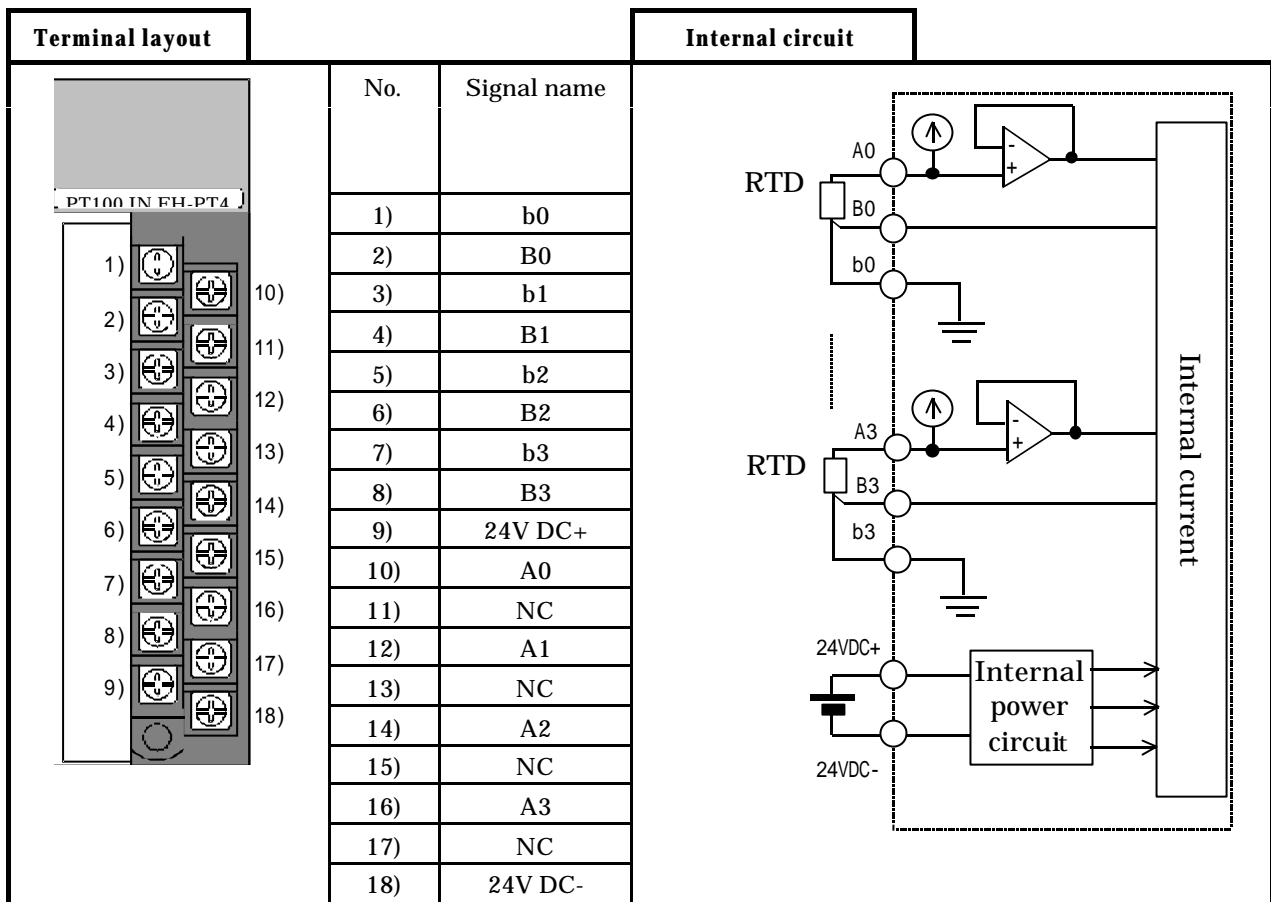

Note 1) Current terminals and a voltage terminals of unused channels should be wired. By this wiring read data becomes H7FFF.

4. Block Diagram

4.1 Internal Block Diagram

Figure 4.1 shows the internal block diagram.

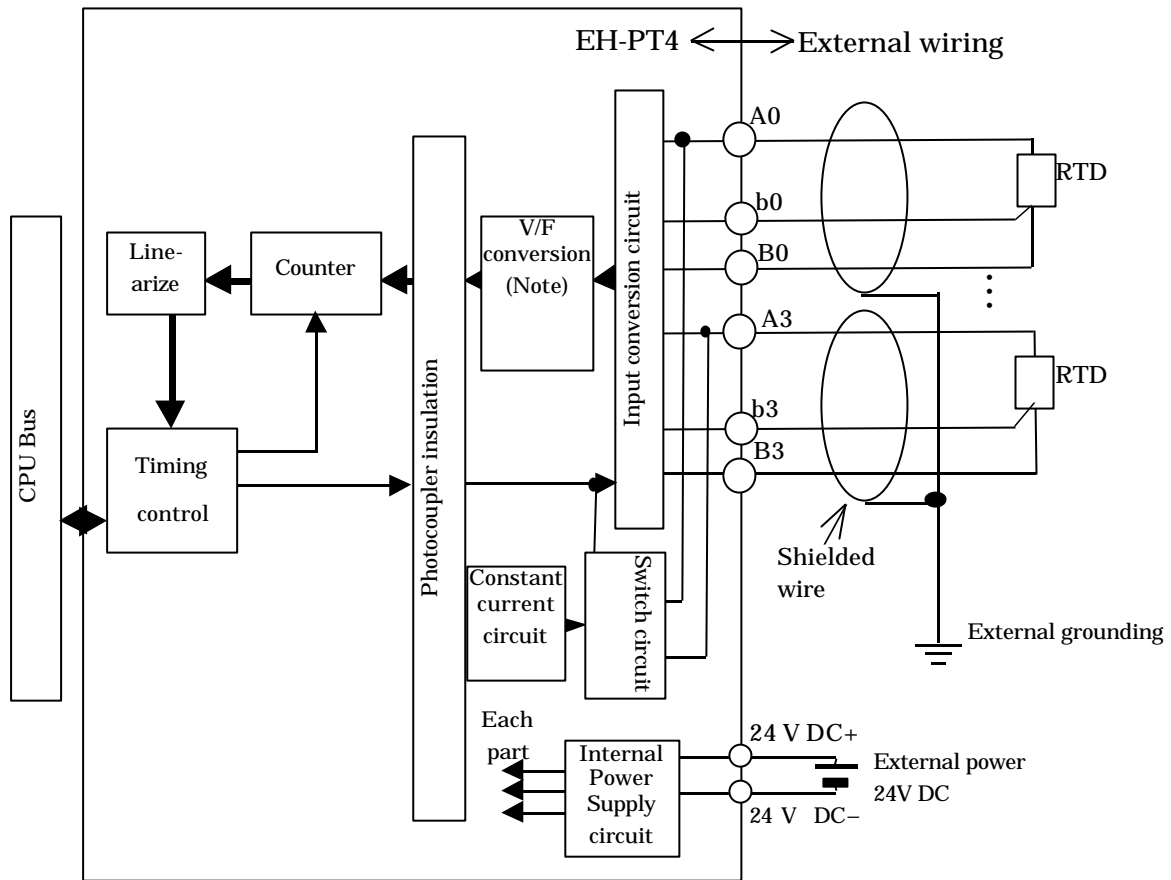

Figure 4.1 Internal Block Diagram

Note: V/F conversion refers to the conversion of voltage(V) to frequency(F).

5. External Wiring

5.1 Resistance Temperature Detective Connection Method and External Wiring

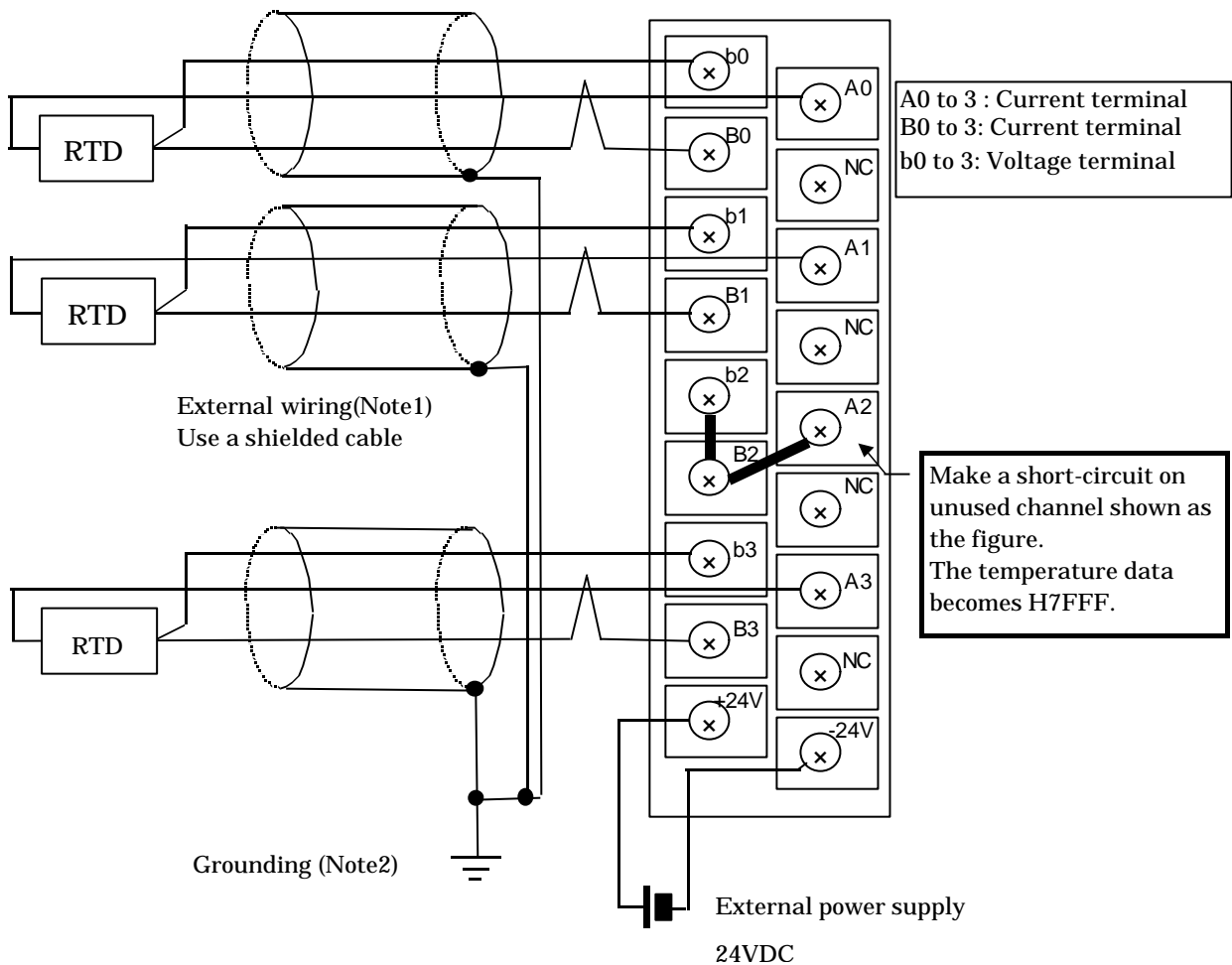

Figure 5.1 External Wiring

Note 1: The external wire length shall be less than 200 m for each channel. In addition, the total resistance of the wires of each channels to be connected to the current terminals (A0 to A3, B0 to B3) shall be less than 400 ohm.

Note 2: Use shielded cable and connect shielded to functional earth on the both sides or one side, which depends on the noise environment.

Note 3: The earth terminal on the power supply module and External power supply 24 VDC must be connected to the functional earth. When functional earth area doesn't do, temperature data sometimes become unstable. The data becomes unspecified.

6. Setting

6.1 Setting of temperature range

This module can be set to three temperature ranges by the dip switch shown in below.

Table 6.1 Temperature range setting

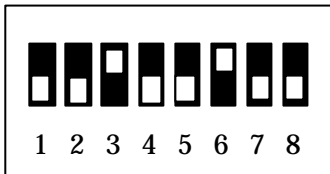
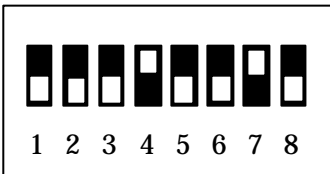
Temperature measurement range	Setting switch	
Pt100 -20 to +40 °C	ON	
	OFF	1,2,5 ON
Pt100 -50 to +400 °C	ON	
	OFF	3,6 ON
Pt1000 -50 to +400 °C	ON	
	OFF	4,7 ON

Note: Do not use the setting which is not written in the table, because the temperature data becomes undefined.

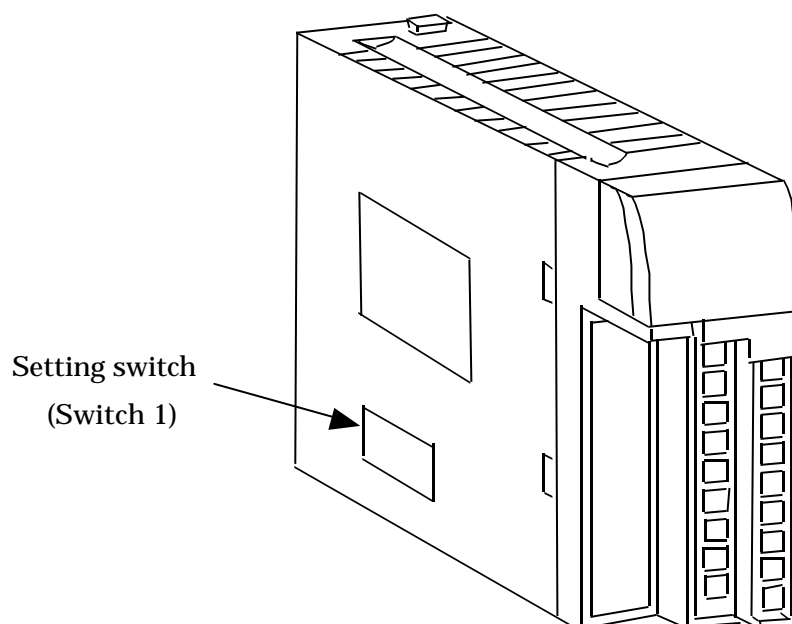

7. Collection of Temperature Data

7.1 I/O Allocation

The temperature data of each channel is collected in the CPU as the temperature conversion data corresponding to the temperature.

(1) I/O assignment

The I/O assignment shall be set as "WX4W" by your programming software or the peripheral equipment.

(2) I/O allocation

Depending on the module installation position, the temperature conversion data is stored in the word input number shown below.

WX	n0	Channel 1 temperature conversion data
	1	Channel 2 temperature conversion data
	2	Channel 3 temperature conversion data
	3	Channel 4 temperature conversion data

Figure 7.1

The setting of n is determined by the module installation position, as shown below.

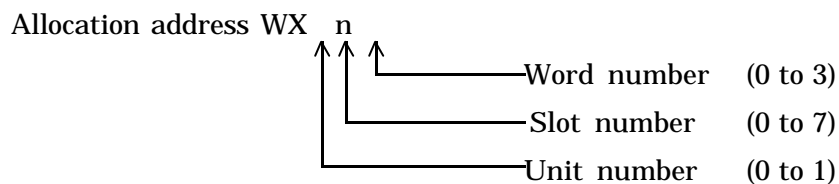
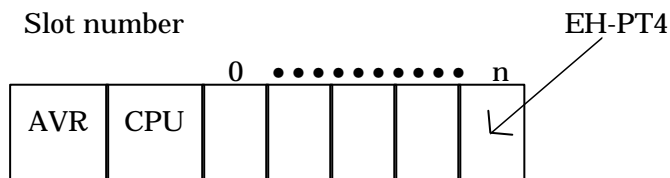

Figure 7.2

7.2 Temperature Data

(1) Content of temperature conversion data [range : -50 to +400 °C] (Pt100/ Pt1000)

The meaning of the each bit(b0 to b15) of temperature conversion data (in WX**) is as shown below.

The sum of the bit "1" is the measured temperature.

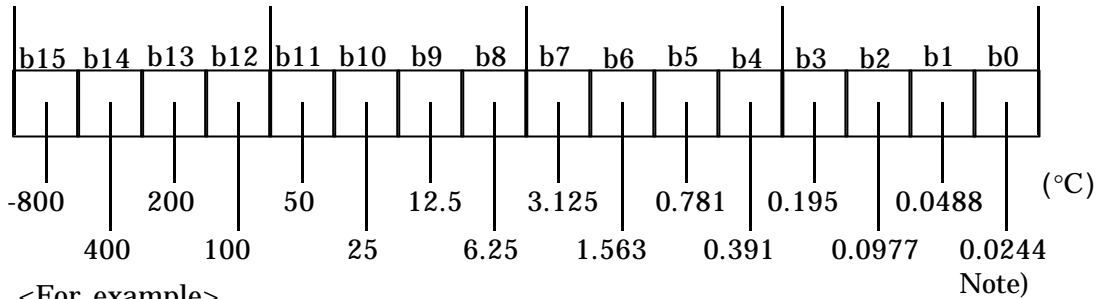

<For example>

- (1) HF800 = " 1111 1000 0000 0000"
 (HF) (H8) (H0) (H0)
 $-800 + 400 + 200 + 100 + 50 = -50 \text{ } ^\circ\text{C}$
- (2) H0600 = " 0000 0110 0000 0000"
 (H0) (H6) (H0) (H0)
 $25 + 12.5 = 37.5 \text{ } ^\circ\text{C}$

When an input error occurs(below -51°C and over $410 \text{ } ^\circ\text{C}$), the temperature conversion data is H7FFF.

The following relation exists between temperature conversion data and actual temperature.

$$\text{Temperature (} ^\circ\text{C) = } \frac{\text{Temperature conversion data(signed decimal data)}}{40.96}$$

Note) "b0" is always "0" in normal time.

Relation between the temperature and temperature conversion data

a) Temperature conversion data(hexadecimal) -50 to +400 °C

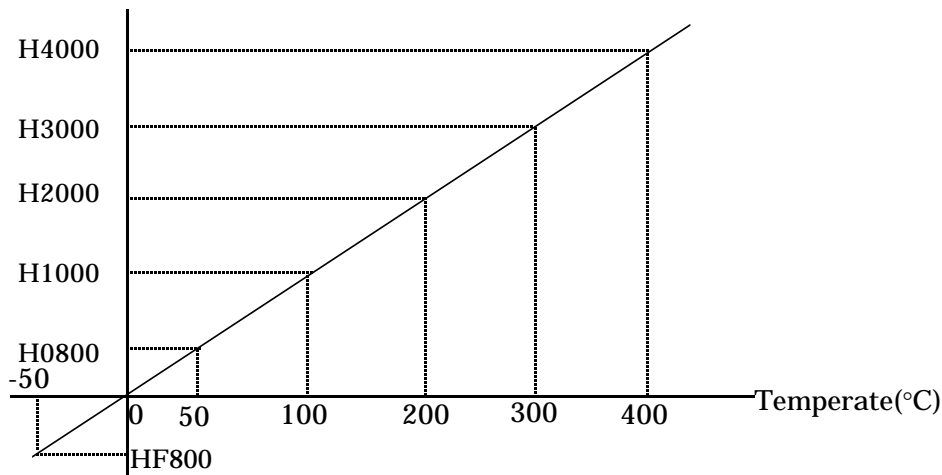
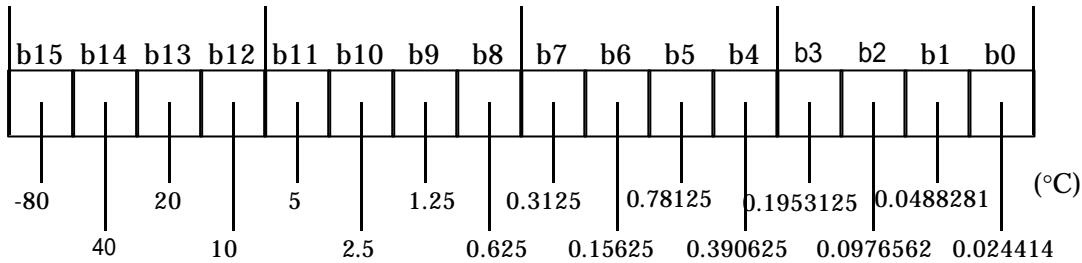

Figure 7.3

(2) Content of temperature conversion data [range : -20 to +40 °C] (Pt100)

The meaning of the each bit(b0 to b15) of temperature conversion data (in WX**) is as shown below.

The sum of the bit "1" is the measured temperature.



Note)

<For example>

(1) HE000 = " 1110 0000 0000 0000"
 (HE) (H0) (H0) (H0)
 $-80 + 40 + 20 = -20\text{ °C}$

(2) H0600 = " 0000 0110 0000 0000"
 (H0) (H6) (H0) (H0)
 $2.5 + 1.25 = 3.75$

When an input error occurs(below -25°C and over 45°C), the temperature conversion data is H7FFF.

The following relation exists between temperature conversion data and actual temperature.

$$\text{Temperature (°C)} = \frac{\text{Temperature conversion data(signed decimal data)}}{409.6}$$

Note) "b0" is always "0" in normal time.

Relation between the temperature and temperature conversion data

b)Temperature conversion data(hexadecimal) -20 to +40 °C

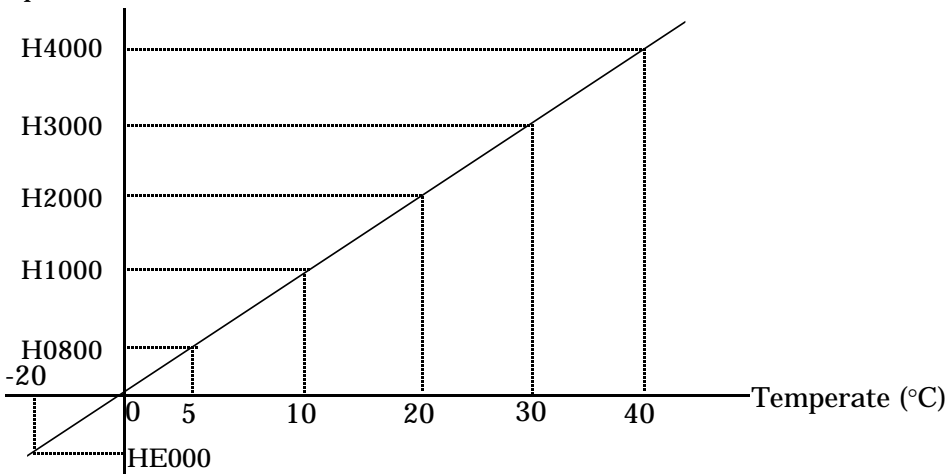

Figure 7.4

7.3 Example of Calculation

The program shown below as an example converts the temperature conversion data in WR0 to BCD 4 digit data in WM6.

In case the temperature is minus, the bit internal output R0 will be turned on.

EXT (DM000,WR0000)	(1)
DM000 = DM000 S* 100	(2)
DM002 = DM000 S/ 4096	(3)
R0 = DM002 S< 0	(4)
ABS (WM004,WM002)	(5)
BCD (WM006,WM004)	(6)

- (1) Because the calculation with sign is that by double words, extend the word temperature conversion data(WR0) to double word data(stored in DM0).
- (2) (3) Calculate by the expression mentioned on previous page. Because the calculation with decimal point (dividing by 40.96) is not possible, multiply the numerator with 100 (2) and then divide by 4,096(3).
- (4) When the temperature data (result of calculation) is minus, the R0 is turned on.
- (5) Turn to an absolute variable (for plus temperature data, use as it is and for minus temperature data remove the sign to turn it to a plus value.) (Use WM0 because the result of calculation can be incorporated in a word (less than 16 bits).
- (6) WM 4 is converted to BCD 4 digits vaule(WM6).

7.4 Correspondence Table between Temperature and Temperature Data

(1)Pt100/Pt1000 -50 to +400 °C range

Table 7.4.1 Pt100 -50 to +400 °C range Temperature conversion data

Temperature (°C) Note1)	Decimal data	Hexadecimal data	Pt100 resistance (Ω) Note 2)	Temperature (°C) Note1)	Decimal data	Hexadecimal data	Pt100 resistance (Ω) Note 2)
-60	63078	F666	72.33	110	4506	1199	142.29
-55	63283	F733	78.32	120	4915	1333	146.06
-50	63488	F800	80.31	130	5325	14CC	149.82
-45	63693	F8CC	82.29	140	5734	1666	153.58
-40	63898	F999	84.27	150	6144	1800	157.31
-35	64102	FA66	86.25	160	6554	1999	161.04
-30	64307	FB33	88.22	170	6963	1B33	164.76
-25	64512	FC00	90.19	180	7373	1CCC	168.46
-20	64717	FCCC	92.16	190	7782	1E66	172.16
-15	64922	FD99	94.12	200	8192	2000	175.84
-10	65126	FE66	96.09	210	8602	2199	179.51
-5	65331	FF33	98.04	220	9011	2333	183.17
0	0	0000	100.00	230	9421	24CC	186.82
5	205	00CC	101.95	240	9830	2666	190.45
10	410	0199	103.90	250	10240	2800	194.07
15	614	0266	105.85	260	10650	2999	197.69
20	819	0333	107.79	270	11059	2B33	201.29
25	1024	0400	109.73	280	11469	2CCC	204.88
30	1229	04CC	111.67	290	11878	2E66	208.45
35	1434	0599	113.61	300	12288	3000	212.02
40	1638	0666	115.54	310	12698	3199	215.57
45	1843	0733	117.47	320	13107	3333	219.12
50	2048	0800	119.40	330	13517	34CC	222.65
55	2253	08CC	121.32	340	13926	3666	226.17
60	2458	0999	123.24	350	14336	3800	229.67
65	2662	0A66	125.16	360	14746	3999	233.17
70	2867	0B33	127.07	370	15155	3B33	236.65
75	3072	0C00	128.98	380	15565	3CCC	240.13
80	3277	0CCC	130.89	390	15974	3E66	243.59
85	3482	0D99	132.80	400	16384	4000	247.04
90	3686	0E66	134.70	410	16794	4199	250.48
95	3891	0F33	136.60				
100	4096	1000	138.50				

Note 1) At the range from -50 to +400 °C of Pt100, the input temperature range is from -50 to +400 °C. But the temperature data output is from -60 to + 410° C.

Note 2) In case of Pt1000, the resistance is 10 times of PT100.

(1)Pt100 -20 to +40 range

Table 7.4.2 Pt100 -50 to +40 °C range Temperature conversion data

Temperature (°C) <small>Note1)</small>	Decimal data	Hexadecimal data	Pt100 resistance (Ω)
-25	55296	D800	90.19
-20	57344	E000	92.16
-15	59392	E800	94.12
-10	61440	F000	96.09
-5	63488	F800	98.04
0	0	0000	100.00
5	2048	0800	101.95
10	4096	1000	103.90
15	6144	1800	105.85
20	8192	2000	107.79
25	10240	2800	109.73
30	12288	3000	111.67
35	14336	3800	113.61
40	16384	4000	115.54
45	18432	4800	117.47

Note 1) At the range from -20 to +40 °C of Pt100, the input temperature input range is from -20 to +40 °C. But the temperature data output is from -25 to +45 .

8. Error Detection Processing

8.1 Measured Temperature Range over

(1) Interlock

If temperature conversion data is over the measuring range or current terminal wiring is disconnected, the temperature conversion data becomes H7FFF.

After this data is read, it is necessary to make a program externally for the treatment for an error.

Example of an error detection program

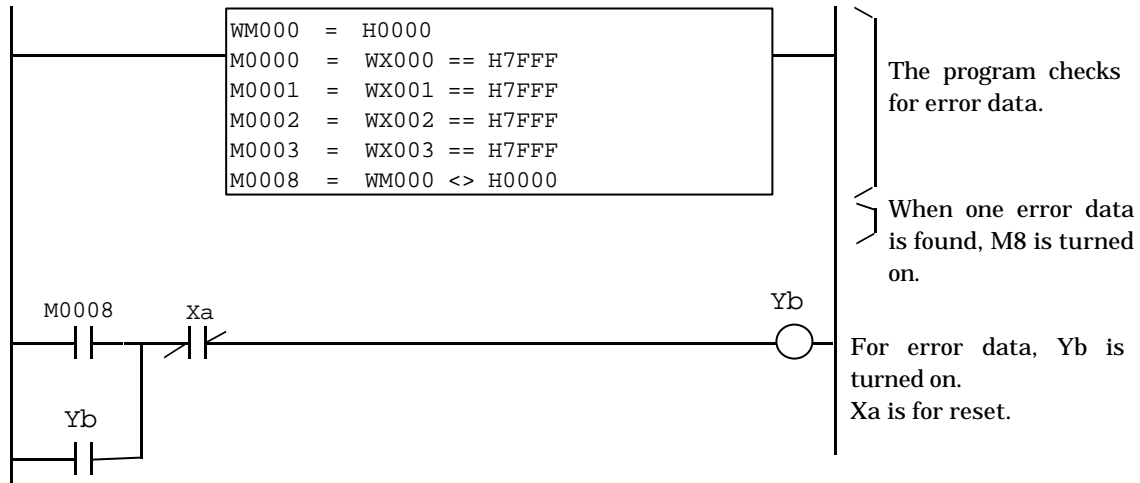

Please take a proper countermeasure by using the coil Yb at error detection (M8 ON).

Set the numbers of the sections "a" and "b" corresponding to the actual system.

8.2 Treatment for a Sudden Change of Temperature Conversion Data

When the temperature conversion data is changed suddenly due to the disconnection of external wiring or influence of noise, the system judges it to be an abnormal condition.

In the example shown below, every scanned data is read in. If a change of 5°C(Note) or more from the previously read data is found, the condition is judged to be abnormal and data is aborted.

Note: Change each value to your system.

Example of program

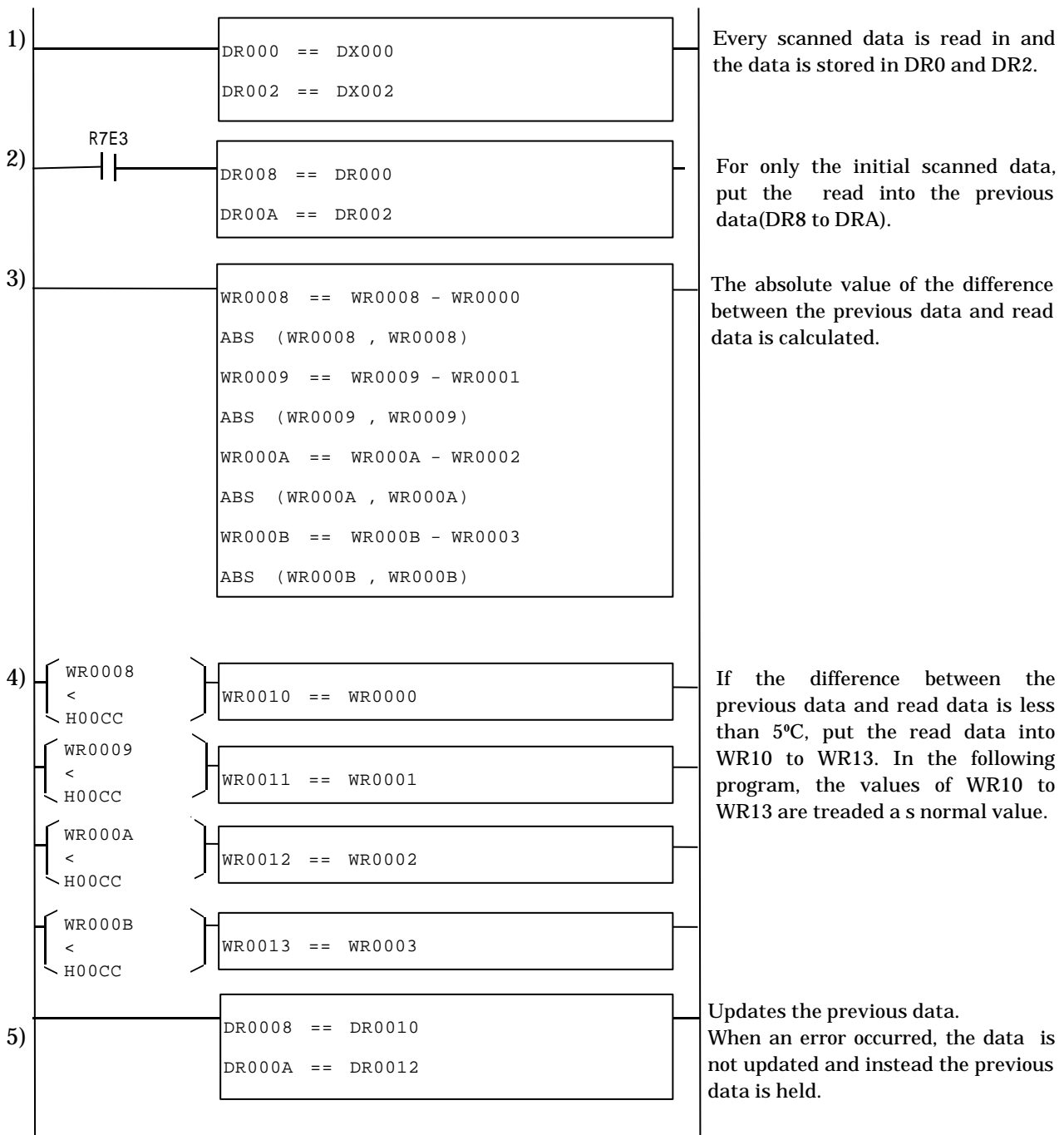

In the example of this program, no protective action or warning against abnormal data is performed. Make additional circuits depending on the situation.

9. Mounting

9.1 Installation

(1) EH-PT4 module can be installed on both the basic base and expansion base.

(2) Precaution on installation

Upon the installation of the EH-150 series, consider the operability, maintainability and environment.

(a) For use at proper ambient temperature range

- Secure a sufficient space allowing a good ventilation.
- Do not install the module just over a device generating a great amount of heat (such as heater, transformer and large capacity resistor).
- If the ambient temperature around the module exceeds 55 °C, set a fan or air conditioner to keep the temperature below 55 °C.

(b) Do not install the module in panel provided with a high-voltage device.

(c) Keep more than 300 mm away from a high-voltage line and power line.

(d) Installing the basic base 1,000 mm through 1,600 mm from the floor improves the operability.

(e) Secure a clearance of more than 50 mm between the upper and lower sections of the module for ventilation and maintenance. For the right and left directions, secure a clearance of more than 10 mm.

(f) Never pull out or insert a alive line of the module.

9.2 Mounting Method

(1) Checking a connector

Before and after the installation, check the following two points.

(a) Is there an abnormality on the connector of the basic base or extensive base?

(b) Is there an abnormality in the connector or the module side?

(2) Confirming the external wiring

Before running, confirm the following items:

(a) Check that the connection of the external wiring is proper.

(b) Check that the external wiring terminal board and the module are fastened securely with screws.

9.3 Maintenance and Inspection

Perform periodic inspection every six months according to the procedure mentioned below.

(1) Remove dust and dirt off the terminal board.

(2) Confirm that the fixing screws of the external wiring terminal board and module are tightened firmly.

9.4 Precautions on External Wiring

Because the external wiring of the EH-PT4 handles fine signals, be sure to use a shielded wire to suppress the influence of external noise and place the wire separately from the power line and signal line of different voltage.

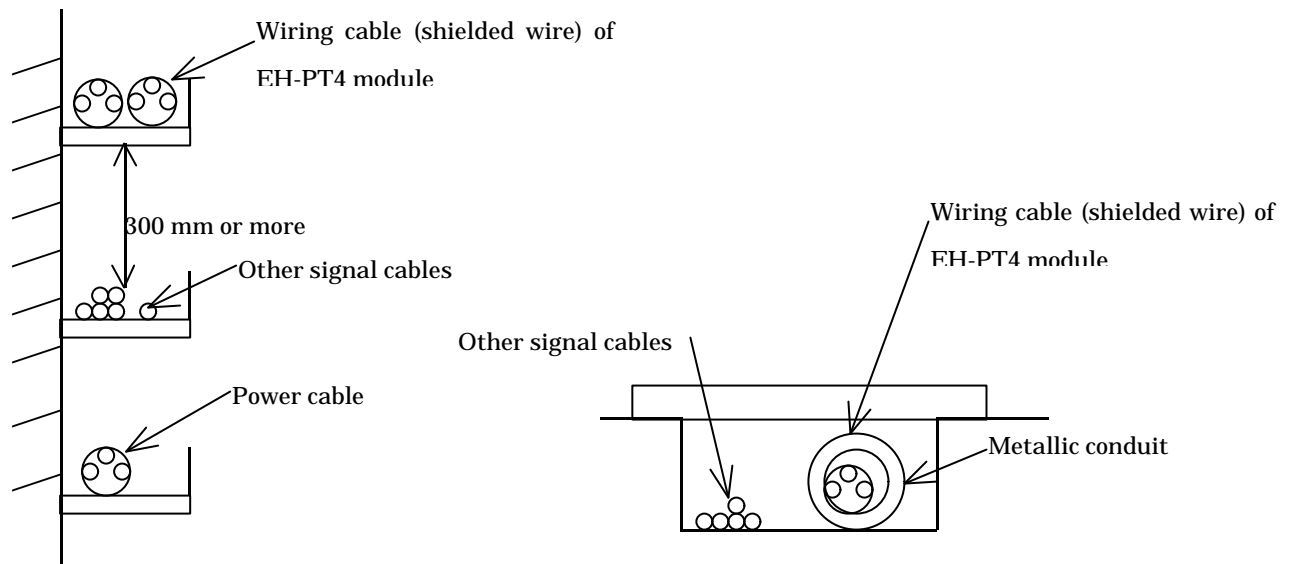

Note) Weld joints of metallic conduits and ground the welded metallic conduits. (Grounding in accordance with local legal requirements)

Figure. 9.1 Wire Separation by Conduits or Ducts

Caution

Use an external power supply which the over current protection character is as below

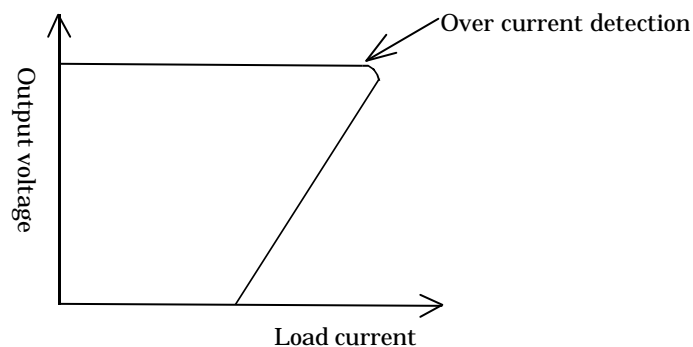

Figure. 9.2 Over current protection character

10. Example of Programming

10.1 Example of Programming 1

(1) Control contents

- (a) The program keeps the temperature of a liquid in a bath 10 to 12°C higher than that of ambient air temperature.
- (b) When the temperature difference between the upper part and the lower part of the liquid is 3°C or higher, the program turns a stirrer on.
- (c) When the temperature of the liquid exceeds 50 °C or the temperature difference between the upper part and the lower part of the liquid exceeds 8 °C, the program turns a temperature error lamp on to indicate an error and starts a cooler.
- (d) When error data is found, the program turns a data error lamp on and starts the cooler.
- (e) When error data is found, the program turns a data error lamp on and starts cooler.
- (f) When an error occurs, the program stops a heater.

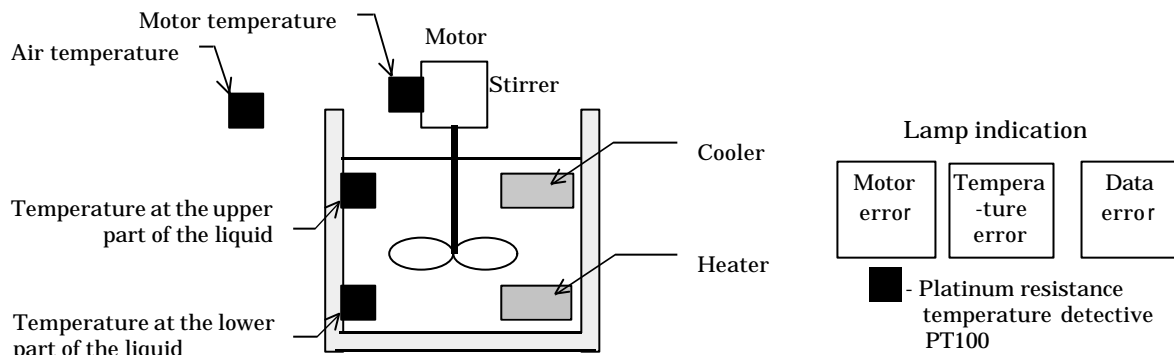

Figure 10.1 External device

(2) Configuration and allocation

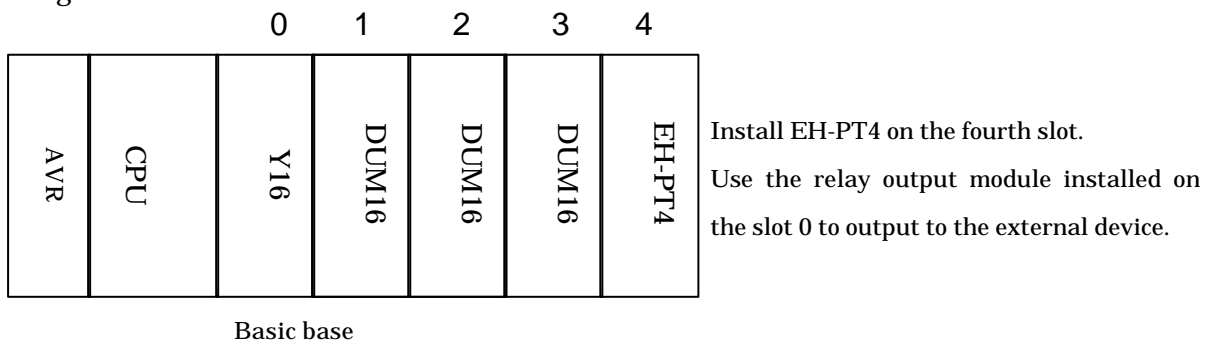

Figure 10.2 PLC configuration

- Y0: Motor
- Y1: Cooler
- Y2: Heater
- Y3: Motor error lamp
- Y4: Temperature error lamp
- Y5: Data error lamp
- WX40: Air temperature
- WX41: Temperature at the upper part of the liquid
- WX42: Temperature at the lower part of the liquid
- WX43: Motor temperature

Setting of temperature range
Pt100 , -50 to +400 °C



(3) Program

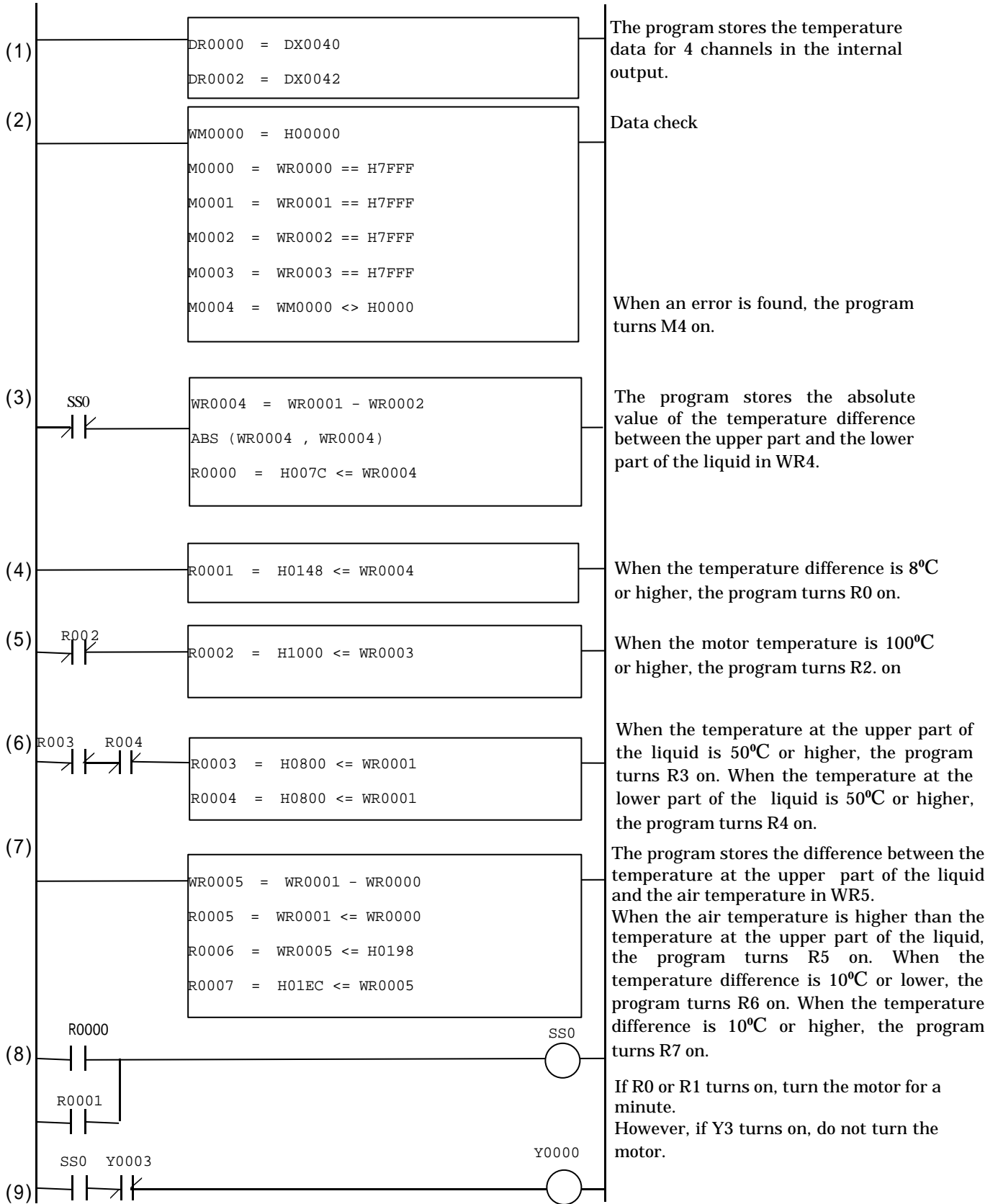

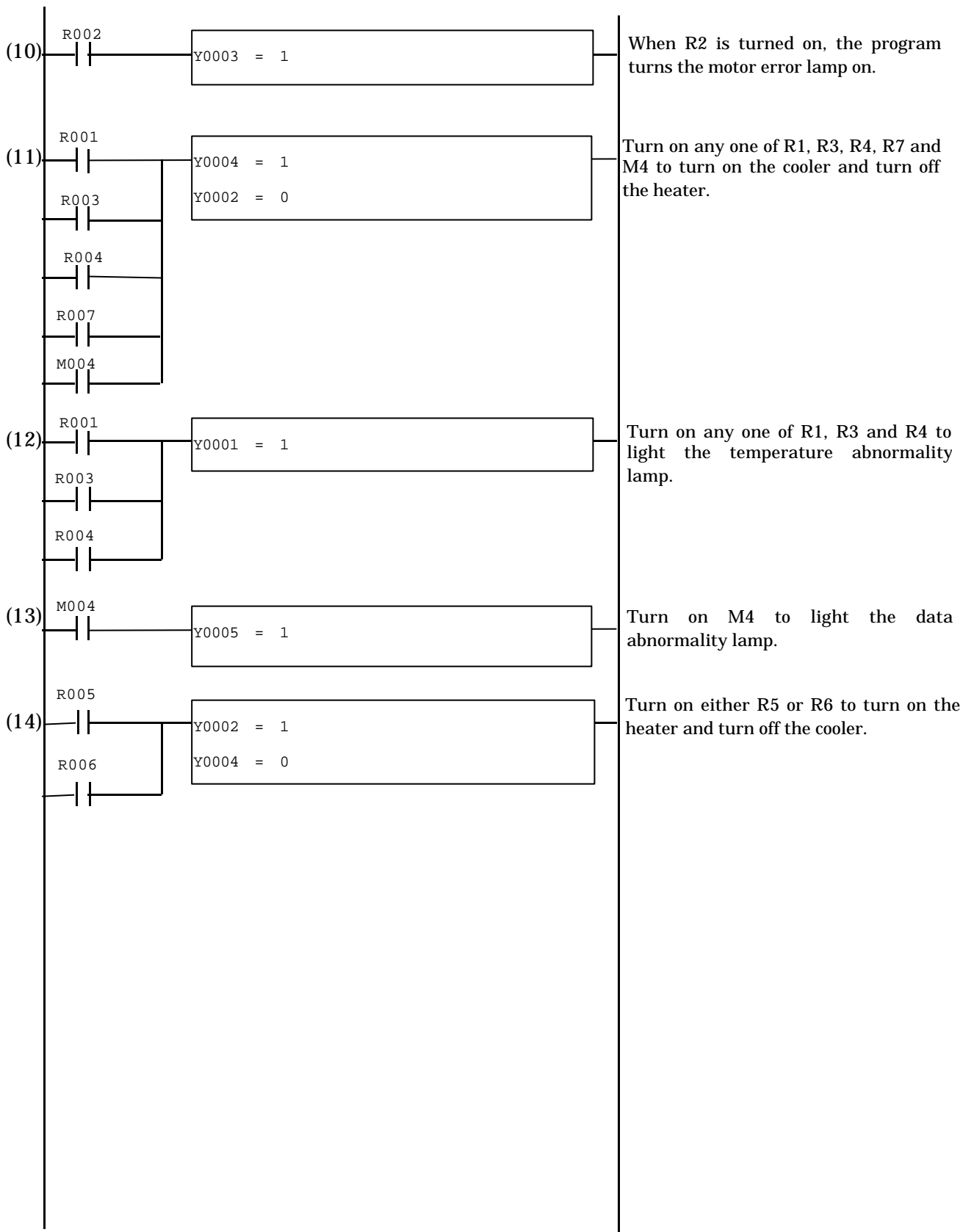

10.2 Example of Programming 2 (Offset adjustment)

The resistance temperature detector itself has a built-in error, therefore an offset error may occur in temperature conversion data. An offset error occurs due to the change with the passage of time also. An example of correction by programming in this case is shown below.

However, because an actual offset value is not always a specified value, it cannot be corrected completely. The offset error refers to the deviation of any temperature conversion data from the reference value (Note) in a specified rate. (The offset error means the constant deviation from the reference value.)

Example of offset

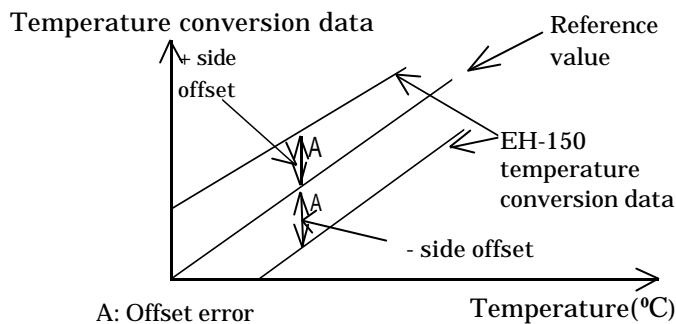

Note: Measure a reference value using a measuring device with a higher accuracy than EH-PT4. Or connect a resistor with a high accuracy instead of the resistance temperature detector and obtain a direct offset error. For the relationship between the temperature and resistance, see Table 7.2.

(1) Adjustment procedure

- (a) Decide whether an offset error is on + or – side toward a reference value.
- (b) Obtain a temperature conversion data corresponding to offset error.

Offset error	Temperature conversion data
1 °C	H0028 or H002C
2 °C	H0050 or H0054
3 °C	H0078 or H007C
4 °C	H00A0 or H00A4
5 °C	H00CC or H00D0

- (c) If offset error is on + side toward the reference value, subtract the value obtained in (b) from the temperature conversion data. If it is on – side, add the value obtained in (b) to the temperature conversion data.

(2) Example of programming (The configuration is the same as the example of programming 1)

If the channel 2 has + 2 °C offset, subtract H0050 from the temperature conversion data WX0042.

```

WR0000 = WX0040
WR0001 = WX0041
WR0002 = WX0042 - H0050
WR0003 = WX0043

```

11 Troubleshooting

If you have some problems, please find the cause according to the following countermeasures. If the problem is not solved despite this countermeasures, contact the sales office.

If a spare unit is available, replace and see the condition.

11.1 The Allocation Error "41" is indicated in CPU.

Error code "41" is "I/O information verify error". I/O assignment information and actual loading of module do not much. (Error codes are output as a hexadecimal to the WRF000.)

- (1) Check the I/O assignment in CPU.
- (2) Check the connection between the module and base.
- (3) A defect may occur from the other modules. Check the other modules. too

11.2 Data Error in a Specific Channel

The type of data errors are (a) unstable data, (b) loss of accuracy and (c) that data is H7FFF.

- (1) Check if the wire for the data undergoing an error in its amount is connected properly.
- (2) Check if the wiring is placed on the same route as the power line (if so, noise is induced.)
- (3) Check if the terminal board screws are tightened securely.
- (4) Check if the resistance temperature detective is the PT100/PT1000 complying with IEC 751.
- (5) Check if the external wiring resistance (current terminal wiring) is less than 400 ohm.
- (6) Check if a measured temperature is out of the specification rage of EH-PT4.

11.3 Data Error in All Channels

The data of all channels may become H7FFF.

- (1) If there is an unused channel, check if its current terminal is correct.
- (2) Check the output voltage of external power supply. Check if the wiring of the current terminal is disconnected.
- (3) Check the capacity of the external power supply.(Output current 1A or more)

[Precautions]

- (1) Before replacing the module, be certain to turn off the power.
- (2) Upon returning a module for a repair, notify us of the details of the abnormal condition.
- (3) For troubleshooting, the following tools are necessary.
 - (a) Phillips screwdriver and slotted screwdriver (+ / -)
 - (b) Digital multi-meter, circuit tester
 - (c) Oscilloscope (necessary depending on the case)

12. Appendix

12.1 Calculation of External Wiring Resistance

Assuming that the cross section and length of tinned annealed copper wire are $S(\text{mm}^2)$, and $L(\text{m})$, the resistance $R(\Omega)$ of the wire is

$$R = 0.01854 \times L / S$$

For example, for a cable whose cross section is 0.18 mm^2 and length is 200 m, the resistance is

$$R = 0.01854 \times 200 / 0.18 = 20.6 \Omega$$

Because the current terminal of EH-PT4 doubles in both ways, the resistance also doubles

$$20.6 \Omega \times 2 = 41.2 \Omega.$$

Because this resistance is the value when the ambient temperature around the wire is $20 \text{ }^\circ\text{C}$, if the ambient temperature is over $20 \text{ }^\circ\text{C}$, the resistance rises. The rise per $1 \text{ }^\circ\text{C}$ is about 0.4%.

In case the ambient temperature is $40 \text{ }^\circ\text{C}$, the resistance is

$$R = 41.2 \times (1 + 0.004 \times (40 - 20))$$

$$44.5 \Omega$$

Concerning the details of resistance, investigate individually for each wire. It may be slightly different from the calculated value.

Reference

In the case of Hitachi twisted shielded cable (CO-DS-IREVV-SX,(10 pairs to 52)), the maximum conductor resistance in the cross section of 0.18mm^2 under the temperature $20 \text{ }^\circ\text{C}$ is 121.5 ohm/km (according to Hitachi's Guide Book).