



ATD-3692

R134A ALUMINIUM MANIFOLD GAUGE SET

WARNING: Always wear safety goggles when working with refrigerants. Contact with refrigerant can cause eye injury.

Disconnect hoses with extreme caution! Pressurized refrigerant may be present in hoses. Always point hoses away from you and anyone nearby.

Your manifold is designed so that all three lower fittings are connected to each other by internal passages. Separate passages from the low and high side fittings to their respective gauges give you pressure and vacuum readings whether the handwheels are open or closed. For your convenience and safety, handwheels and gauges are color-coded with the blue compound gauge on the left or low side, and the red pressure gauge on the high or right side.

Diagnosing System Operation

1. Connect the blue low side hose to the A/C system's low side service port. Connect the red high side hose to the A/C system's high side service port.
2. With the manifold handwheels closed, read the pressure on the gauge face.
3. Use the temperature/pressure chart in the back of this manual to find the corresponding temperature for the refrigerant in the system.
4. Compare these pressure and temperatures to the A/C system manufacturer's specifications for proper operation.
5. If the system is within the correct operating guidelines, disconnect the manifold hoses from the system. If repairs are necessary, follow the steps for recovering, evacuating and recharging the system.

Recovering Refrigerant

Note: According to federal law, refrigerant should not be exhausted to the atmosphere.

1. Be sure the blue low side hose is connected to the A/C system's low side service port and that the red high side hose is connected to the A/C system's high side service port.

Note: Typically, the yellow center hose is connected to the inlet of the recovery unit.

2. Follow the instructions provided with the recovery unit for proper recovery of refrigerant from the A/C system.

Evacuating and Charging a Refrigerant System

1. Connect the blue low side hose to the A/C system's low side service port. Connect the red high side hose to the A/C system's high side service port.
2. Check the manifold gauge pressure reading to be sure the A/C system has been recovered properly. If it is not, follow steps under "Recovering Refrigerant". If it is, connect the center yellow charging hose to a vacuum pump.
3. Open the high and low side handwheels and start the vacuum pump.
4. After evacuating the system according to the manufacturer's specifications, close both the high and low side handwheels and turn off the vacuum pump.
5. Disconnect the yellow hose from the vacuum pump and connect it to the refrigerant supply.
6. Slightly open the refrigerant supply valve. Purge air from the yellow charging hose at the manifold, then close the supply valve.
7. You can now charge the A/C system according to the manufacturer's specifications.
 - If the system specifications call for charging on the high side, close the manifold's blue low side handwheel, open the refrigerant supply valve and open the manifold's red high side handwheel. After dispensing the proper amount of refrigerant, close the manifold's red high side handwheel and close the refrigerant supply valve.
 - If the system specifications call for charging on the low side, close the manifold's red high side handwheel, open the refrigerant supply valve and open the manifold's blue low side handwheel. After dispensing the proper amount of refrigerant, close the manifold's blue low side handwheel and close the refrigerant supply valve.
8. When you have charged the system, close both manifold handwheels. Let the compressor run and check the manifold's gauge pressure readings to be sure the system is operating properly. If it is not, adjust the system as necessary. To disconnect the manifold when the system is operating correctly, first close the high side coupler valve. Open the low side coupler valve. Then disconnect the red high side hose from the A/C system.
9. Restart the A/C system, then open both manifold handwheels. Refrigerant from both hoses will be drawn quickly into the A/C system through the blue low side hose.
10. When both gauges show the lowest operating pressure recommended by the manufacturer, close the low side valve and turn off the A/C system.
11. Close the low side coupler valve and disconnect the low side hose from the A/C

system.

MAINTAINING YOUR MANIFOLD

To keep your manifold in top operating condition:

- Periodically replace O-rings and valve seats.
- Be sure to lubricate O-rings with High Vacuum Grease.

Because of ongoing product improvements, we reserve the right to change design, specifications, and materials without notice.

SERVICE COUPLER OPERATION

Field service couplers are provided to access the vehicle's service ports. The service coupler should be in the closed position before connecting to the male fitting on the vehicle.

- Turn knurled collar to the left, and then push on with a snap. Turn knurled collar to the right to engage refrigerant in valve.
- Turn knurled collar back to the left to disengage.
- Pull bottom sleeve up to release from the adapter.
- This coupler is non-venting by design.

MANIFOLD OPERATING INSTRUCTIONS



ATD-3692

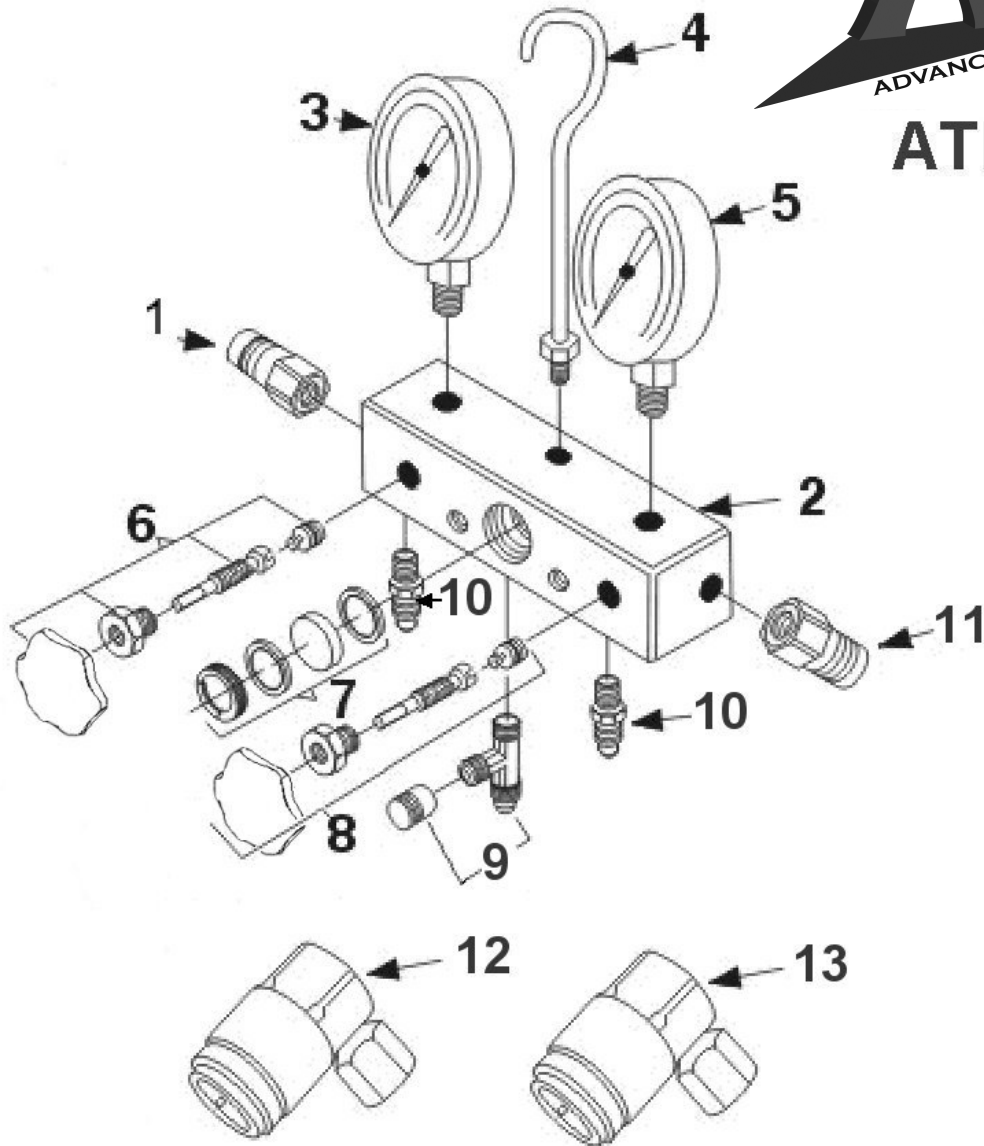

ORDERING PART#	ITEM#	PART DESCRIPTION
PRT3692-01	1	LOW SIDE HOSE HANGER
PRT3692-02	2	MANIFOLD BAR (W/O GAUGES)
ATD3677	3	COMPOUND GAUGE (BLUE)
PRT3689-04	4	HANGING HOOK
ATD3676	5	PRESSURE GAUGE (RED)
PRT3692-06	6	COMPLETE STEM ASSY (BLUE)
PRT3692-07	7	VIEWING GLASS
PRT3692-08	8	COMPLETE STEM ASSY (RED)
PRT3692-09	9	BRASS TEE FITTING W/CAP
PRT3692-10	10	BRASS FITTING
PRT3692-11	11	HIGH SIDE HOSE HANGER
ATD3597B	12	LOW SIDE COUPLER 90°
ATD3596B	13	HIGH SIDE COUPLER 90°
PRT3692-14	14*	RED HOSE (60") 800/4000 PSI
PRT3691-10	15*	YELLOW HOSE (60") 800/4000 PSI
PRT3692-16	16*	BLUE HOSE (60") 800/4000 PSI

* HOSES NOT SHOWN ON DRAWING



Temperature/Pressure Chart

Temp °F	R-12 Vapor	R-134a Liquid
-50	15.4	18.7
-45	13.3	16.9
-40	11	14.8
-35	8.4	12.5
-30	5.5	9.8
-25	2.3	6.9
-20	0.6	3.7
-15	2.4	0.1
-10	4.5	1.9
-5	6.7	4.1
0	9.1	6.5
+5	11.8	9.1
+10	14.6	11.9
+15	17.7	15
+20	21	18.4
+25	24.6	22.1
+30	28.4	26
+35	32.5	30.3
+40	36.9	35
+45	41.6	40
+50	46.7	45.4
+55	52	51.1
+60	57.7	57.3
+65	63.7	63.9
+70	70.2	71
+75	76.9	78.6
+80	84.1	86.6
+85	91.7	95.1
+90	99.7	104.2
+95	108.2	113.8
+100	117.1	124.1
+105	126.5	134.9
+110	136.4	146.3
+115	146.7	158.4
+120	157.6	171.1
+125	169	184.5
+130	180.9	198.7
+135	193.5	213.6
+140	206.5	229.3
+145	220.2	245.7
+150	234.5	263

RED = Vacuum