

# **E4H-CE AND E8-CE SERIES WATER PURIFICATION MACHINES**

**3 m<sup>3</sup>/hr to 45 m<sup>3</sup>/hr  
18,000 gpd to 288,000 gpd**

**Operation and Maintenance  
Manual**



***GE Osmonics***



**INSTRUCTIONS FOR E4H-CE AND E8-CE  
WATER PURIFICATION  
OPERATION AND MAINTENANCE MANUAL**

**TABLE OF CONTENTS**

	<u>Page</u>
1.0 DESCRIPTION .....	1
1.1 Definitions.....	1
1.1.1 Permeate Rate.....	1
1.1.2 Concentrate Rate.....	1
1.1.3 Feed Rate.....	1
1.1.4 Reverse Osmosis.....	1
1.1.5 Membrane Elements.....	2
1.1.6 Clean-In-Place.....	2
1.1.7 Flow Control Center.....	2
1.1.8 Average Pressure.....	2
1.1.9 Concentration.....	2
1.1.10 Salt (Ionic) Passage.....	3
1.1.11 Recovery.....	3
1.1.12 Salt (Ionic) Rejection.....	3
1.2 Machine Nomenclature.....	5
1.3 Features.....	5
1.4 Specifications for E-CE Series Machines.....	7
1.4.1 Feed Water Specifications.....	8
1.4.2 Permeate Flow Rate.....	8
1.4.3 Concentrate Flow Rate.....	8
1.4.4 Pressure Range.....	8
1.4.5 Reverse Osmosis Membrane Element Rejection.....	9
2.0 INSTALLATION.....	10
2.1 Feed Water Requirements.....	10
2.2 Mounting.....	10
2.3 Plumbing.....	11
2.4 Power and Electrical Requirements.....	11
3.0 PREPARATION FOR START-UP.....	12
3.1 Pretreatment for Water Purification.....	12
3.2 Initial Start-Up.....	12
3.3 Daily Start-Up.....	16

	<u>Page</u>
4.0 MACHINE OPERATION AND MAINTENANCE .....	17
4.1 Daily Log Sheets .....	17
4.2 Pre-Filter Cartridge .....	17
4.3 Cleaning .....	17
4.4 Draining Machine for Shipment .....	19
4.5 Membrane Element Replacement .....	19
4.6 Membrane Element Removal .....	21
5.0 FIELD INSTALLED ACCESSORIES .....	22
5.1 Pretreatment Shutdown .....	22
5.2 Permeate Flush .....	22
5.3 Chemical Pump .....	24
5.4 Clean-In-Place Installation .....	24
6.0 TROUBLESHOOTING .....	25
7.0 FORMS .....	33
7.1 Return Goods Authorization (RGA) .....	33
7.2 Start-Up Data Sheet .....	34
7.3 Daily Log Sheet .....	35
8.0 WARRANTY/GUARANTEE .....	36
8.1 Warranty Terms .....	36
8.2 Warranty Commencement Date .....	36
8.3 Warranty Service .....	36
8.4 Voidability of Warranty .....	37
8.5 Limitations and Exclusions .....	37

**LIST OF FIGURES**

<u>Figure</u>	<u>Title</u>	
1.1	Normal Versus Cross Flow Filtration .....	1
1.2	Membrane Element With Interconnectors .....	2
1.3	Principles of Operation .....	3

**LIST OF TABLES**

<u>Figure</u>	<u>Title</u>	
1.1	Flow Specifications for E-CE Reverse Osmosis Machines .....	7
1.2	Minimum/Maximum Boost Pressure .....	8
1.3	Membrane Element Specifications .....	9
2.4	Feed Water Requirements .....	10
2.5	Connections .....	11

## 1.0 DESCRIPTION

E-CE Series Reverse Osmosis (RO) machines are durable pieces of equipment, which, with proper care, will last for many years. These instructions give operation and maintenance details vital to the sustained performance of the machine. Please read completely before operating your machine.

### 1.1 Definitions

The operating definitions provided below will help you further understand your machine and this manual.

#### 1.1.1 Permeate Rate (Product Water Rate) [ $Q_p$ ]

The Permeate Rate is the flow rate of purified water that passed through the membrane element and out of the membrane element in liter/min (Lpm), cubic meters/hour ( $m^3/h$ ), gallons/min (gpm) or gallons/hour (gph). Specified permeate rates are based on a feed water temperature of  $25^\circ C$  ( $77^\circ F$ ). Permeate rate will vary with temperature.

#### 1.1.2 Concentrate Rate (Wastewater Rate) [ $Q_c$ ]

The Concentrate Rate is the flow of incoming water in Lpm or  $m^3/h$  (gpm or gph).

#### 1.1.3 Feed Rate [ $Q_f$ ]

The Feed Rate is the flow rate of incoming water in Lpm or  $m^3/h$  (gpm or gph). Feed water rate equals permeate plus concentrate rate.

#### 1.1.4 Reverse Osmosis

Reverse Osmosis (RO) is the separation of one component in a solution from another component of a solution from another component by means of pressures exerted on a semi-permeable membrane element. The feed solution is separated into two streams, permeate and concentrate, and collected from both sides of the membrane element.

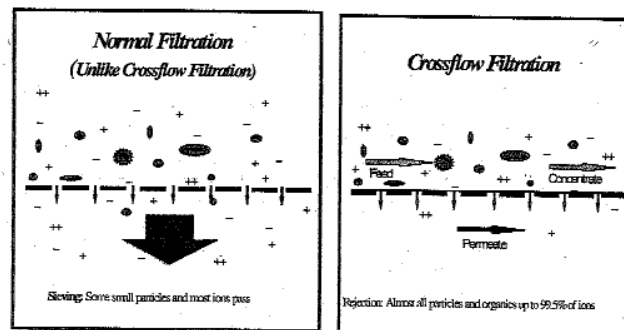

**Figure 1.1**  
**Normal Versus Cross Flow Filtration**

### 1.1.5 Membrane Elements

Membrane elements are interleaved layers of semi-permeable membrane, spacer, and permeate carrier spiraled around a central permeate tube make up the membrane element.

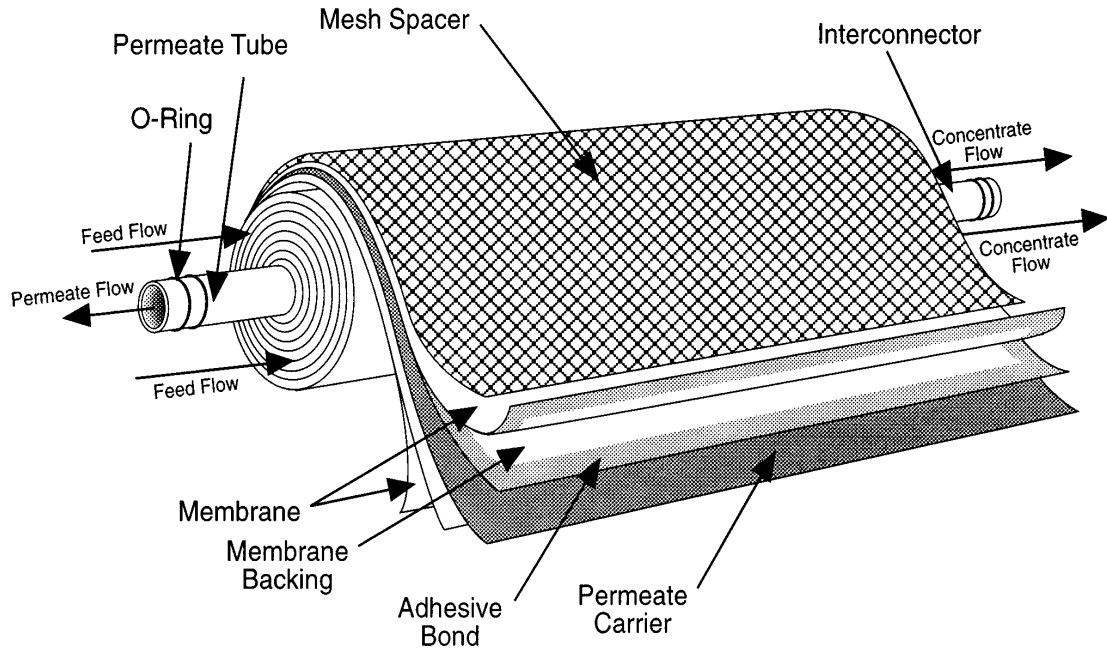

**Figure 1.2**  
**Membrane Element with Interconnectors**

### 1.1.6 Clean-In-Place

The abbreviation for Clean-In-Place is CIP.

### 1.1.7 Flow Control Center

The Flow Control Center features a concentrate flow control valve, a recycle flow control valve, and a pressure gauge. It is located directly behind the control enclosure.

### 1.1.8 Average Pressure

$$P_{AVG} \text{ (Average Pressure)} = [(P_{PRIMARY} + P_{FINAL}) \div 2]$$

### 1.1.9 Concentration

Concentration equals the Total Dissolved Solids (TDS) concentration of a solution expressed as conductivity ( $\mu\text{S}/\text{cm}$ ) or parts per million (ppm).

- $C_f$  = Feed Concentration
- $C_p$  = Permeate Concentration
- $C_c$  = Concentrate Concentration
- $C_{avg}$  = Average Concentration in Machine

1.1.10 Salt (Ionic) Passage

Ionic Salt Passage equals the percent of dissolved salts passed through the membrane element or 100% minus rejection.

1.1.11 Recovery

Recovery equals permeate rate divided by feed rate and is expressed as a percentage. For example, 75% recovery means that out of a given feed rate, 75% is produced as purified water (permeate).

1.1.12 Salt (Ionic) Rejection

Ionic Salt Rejection equals the percent of dissolved salt rejected by the membrane element, calculated from an average concentration over the membrane element.

An example of how to calculate salt rejection and recovery is below:

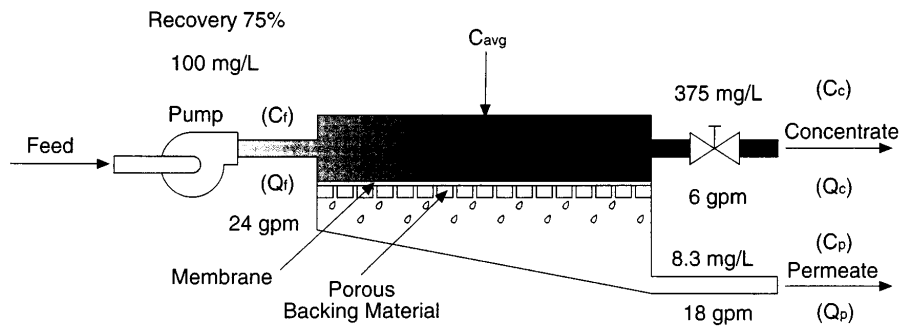

**Figure 1.3**  
**Principles of Operation**

Given the system case in Figure 1.3:

$$\begin{aligned}
 \text{Average Concentration } (C_{avg}) &= \frac{[(C_f) + (C_c)]}{2} \\
 &= \frac{[(100 \text{ mg/L}) + (375 \text{ mg/L})]}{2} \\
 &= 237.5 \text{ mg/L}
 \end{aligned}$$



$$\begin{aligned}
 \text{Rejection} &= \frac{[(C_{\text{avg}}) - (C_P)] \times 100}{(C_{\text{avg}})} \\
 &= \frac{[(237.5 \text{ mg/L}) + (8.3 \text{ mg/L})] \times 100}{(237.5)} \\
 &= 96.5\%
 \end{aligned}$$

$$\begin{aligned}
 \text{Passage} &= \frac{(C_P) \times 100}{(C_f)} \\
 &= \frac{(8.3 \text{ mg/L}) \times 100}{(237.5)} \\
 &= 3.5\%
 \end{aligned}$$

$$\begin{aligned}
 \text{Recovery} &= \frac{(Q_P) \times 100}{(Q_f)} \\
 &= \frac{(18 \text{ gpm}) \times 100}{(24 \text{ gpm})} \\
 &= 75\%
 \end{aligned}$$

## 1.2 Machine Nomenclature

E-CE Series water purification machines are numbered in such a way as to indicate the permeate flow you can expect from the machine and other specifications:

Example: RE, E8-CE-9, 400, 5, 66 - 75

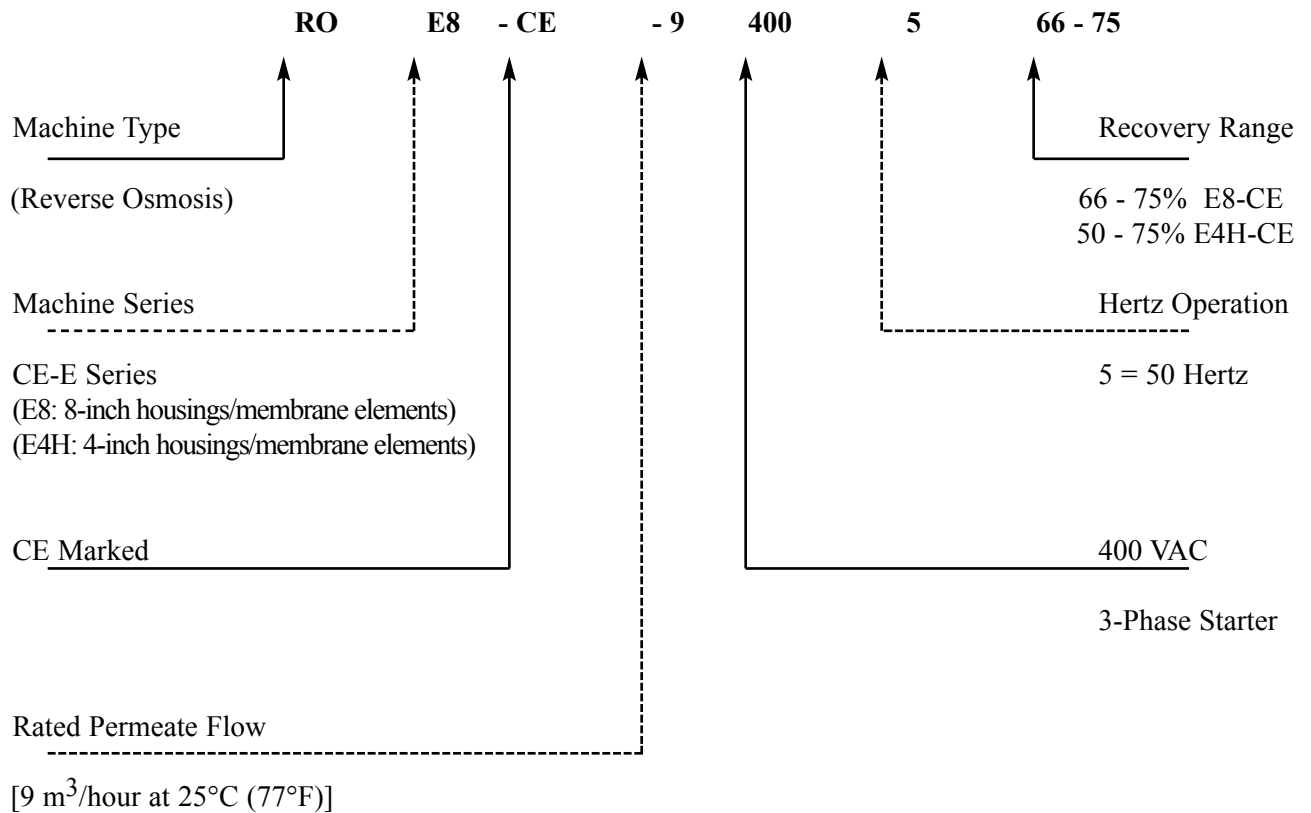

## 1.3 Features

E4H-CE and E8-CE water purification machines have all the features necessary for safe, continuous production of high-purity water. This assumes properly pretreated feed water with a TDS ≤ 2000 ppm and regular operator maintenance.

- Sixty-six (66) - 75% recovery (E8-CE) or 50 - 75% recovery (E4H-CE). Adjust concentrate and recycle flows to obtain desired recovery.
- Epoxy-coated carbon steel frame.
- Three hundred fifty (350) square foot or 85 square foot (E4H-CE) membrane elements with stainless steel (SS) membrane element housings.

- Multi-stage centrifugal pump, SS construction (SS end castings and wetted parts, Noryl\* internals) on the 3 to 3 to 34m<sup>3</sup>/hr and AS (all Stainless Steel components) on the 45m<sup>3</sup>/hr.
- Electrical package includes Programmable Logic Controller (PLC), IEC66 control enclosure with a 24VDC control circuit, Siemens TP070 operator interface terminal, and a Siemens S7-200 PLC.
- Twenty (20)-inch, 30-inch, or 40-in SS pre-filter housing, including 5-micron cartridge filters, GS05-20-XK, GX05-30-XK, GX05-40-XK for the E8-CE and 20-inch PVC pre-filter housings, including 5-micron cartridge filters for the E4H-CE.
- Pre-filter, post-filter, primary, pump discharge, and final pressure gauges.
- Concentrate and permeate flow meters.
- Digital conductivity monitor, panel-mounted, for permeate quality monitoring with high conductivity alarm.
- Gauges, valves, and rigid plumbing of SS or plastic.
- Stainless Steel concentrate and recycle valves.
- External control capabilities (level control, pretreatment lockout).
- ALARMS included: low inlet pressure, high permeate pressure, high conductivity, high pH, starter overload trip, and high temperature.
- Permeate purge capability.
- High permeate pressure shutdown.
- Low inlet pressure shutdown.

---

\* Noryl is a trademark of General Electric Company.

1.4 Specifications for E-CE Series Machines

The machine flow specifications listed, Table 1.1 below, are based on 25°C (77°F) and 2000 ppm NaCl.

**Table 1.1  
Flow Specifications for  
Reverse Osmosis  
E-CE Machines**

<b>MODEL</b>	<b>E4H-CE-3</b>	<b>E4H-CE-5</b>	<b>E4H-CE-7</b>	<b>E4H-CE-9</b>	<b>E4H-CE-14</b>	<b>E4H-CE-23</b>
<b>Recovery</b>	50-75%	50-75%	50-75%	66-75%	66-75%	66-75%
<b>Units</b>	LPM/GPM	LPM/GPM	LPM/GPM	LPM/GPM	LPM/GPM	LPM/GPM
<b>Permeate Rate</b>	47.4/12.5	78.9/20.9	126.3/33.4	151.4/40.0	227.1/60.0	378.5/100.0
<b>Concentrate Rate (50-66%)</b>	47.4/12.5	78.9/20.9	126.3/33.4	75.7/20.0	113.6/30.0	189.3/50.0
<b>Concentrate Rate (75%)</b>	15.8/4.2	26.3/7.0	42.1/11.1	50.5/13.3	75.7/20.0	126.2/33.3
<b>Feed Rate (50-66%)</b>	94.7/25.0	157.8/41.7	252.5/66.7	227.1/60.0	340.7/90.0	567.8/150.0
<b>Feed Rate (75%)</b>	63.1/16.7	105.2/27.8	168.4/44.5	201.9/53.3	302.8/80.0	504.7/133.3
<b>Recycle Rate (55-66%)</b>	15.1/4.0	0.0/0.0	0.0/0.0	68.1/18.0	107.3/45.0	56.8/15.0
<b>Recycle Rate (75%)</b>	46.6/12.3	46.2/12.2	81.5/21.5	93.4/24.7	208.2/55.0	119.9/31.7

1.4.1 Feed Water Specifications

The feed water requirements listed in Table 1.1 must be met to ensure quality permeate and extended membrane element life.

1.4.2 Permeate Flow Rate

Stated in Table 1.1 and on the machine serial number label (assumes no permeate back pressure, 2000 mg/L Total Dissolved Solids (TDS) maximum feed concentration, and rated temperature).

To estimate permeate output with back pressure, use the formula below. Maximum permeate back pressure is 80 psig (5.5 bar).

$$\text{(Specified Permeate)} \times \frac{[(\text{Operating Pressure}) - (\text{Permeate Back pressure})]}{(\text{Operating Pressure})}$$

1.4.3 Concentrate Flow Rate

Stated in Table 1.1 and factory-set as stated on the serial number label.

1.4.4 Pressure Range

The Pressure Ranges listed below (Table 2.1) are boost pressure:

$$\text{Boost Pressure} = [(\text{Primary Pressure} - (\text{Post-Filter Pressure}))].$$

**Table 1.2**  
**Minimum/Maximum (Min/Max)**  
**Boost Pressure**

<b>MODEL</b>	<b>PUMP MODEL</b>	<b>PRIMARY PRESSURE RANGE bar (psi)</b>
<b>E4H-CE-3</b>	Tonkaflo, SS2823G-50	8.6 - 15.5 (125 - 225)
<b>E4H-CE-5</b>	Tonkaflo, SS2823G-50	7.6 - 15.5 (110 - 225)
<b>E4H-CE-7</b> <b>E8-CE-9</b>	Tonkaflo, SS2823G-50	6.6 - 14.4 (100 - 210)
<b>E8-CE-14</b>	Tonkaflo, SS2823G-50	6.6 - 12.8 (95 - 185)
<b>E8-CE-23</b>	Tonkaflo, SS2823G-50	5.2 - 9.3 (75 - 135)

#### 1.4.5 Reverse Osmosis Membrane Element Rejection

E8-CE RO machines use Fiberglass Reinforced Plastic (FRP). E4H-CE RO machines use tape wrapped membrane elements. For more information, refer to the Spare Parts List (P/N 1233377).

**Table 1.3  
Membrane Element  
Specifications**

<b>Specification</b>	<b>E4H-CE</b>	<b>E8-CE</b>
<b>Outer Cover Material</b>	<b>Tape</b>	<b>FRP</b>
<b>Typical Ionic Rejection (TDS)</b>	<b>98.0 - 99.5%</b>	<b>98.0 - 99.5%</b>
<b>Nominal Permeate Flow Rate [at 7.6 bar (110 psi)]</b>	<b>8.3 m<sup>3</sup>/d (2200 gpd)</b>	<b>39.8 m<sup>3</sup>/d (10500 gpd)</b>
<b>Typical Feed Water Temperature Range</b>	<b>10° - 29°C (50° - 85°F)</b>	<b>10° - 29°C (50° - 85°F)</b>
<b>Maximum Temperature Range</b>	<b>0° - 40C (32° - 104°F)</b>	<b>0° - 40°C (32° - 104°F)</b>
<b>Short-Term Cleaning Temperature</b>	<b>&lt; 43°C (110°F)</b>	<b>&lt; 43°C (110°F)</b>
<b>pH Range</b>	<b>3.0 - 11.0</b>	<b>3.0 - 11.0</b>
<b>Chlorine Tolerance</b>	<b>&lt; 0.1 ppm</b>	<b>&lt; 0.1 ppm</b>
<b>Active Membrane Area</b>	<b>7.9 m<sup>2</sup> (85 ft<sup>2</sup>)</b>	<b>32.5 m<sup>2</sup> (350 ft<sup>2</sup>)</b>
<b>Average Molecular Weight Cutoff*</b>	<b>1500 MW*</b>	<b>1500 MW*</b>

\* The Molecular Weight (MW) cutoff is based on the pore size of membrane elements and the nature (size/shape) of the organic molecule.

## 2.0 INSTALLATION

The following installation guidelines will help you install your new E-CE RO machine.

### 2.1 Feed Water Requirements

The following feed water requirements must be met before installing your new E-CE RO machine to ensure quality permeate and extended membrane element life.

**Table 2.4**  
**Feed Water Requirements**

Temperature	Typical: 10 - 29°C (50° - 85°F)
Inlet Pressure	Minimum: 2.1 barg (30 psig) Maximum: 4.1 barg (60 psig)
Chlorine (continuous feed)	0 ppm
Feed Water	For soft water [less than 1 grain per gallon (gpg) or 17 mg/L hardness] acceptable pH: 3.0 - 11.0
	For unsoftened water (contact factory for water analysis), acceptable pH: 5.0 - 6.0
	For short-term (i.e., cleaning) acceptable SDI range: 2 - 12
Silt Density Index (SDI)	Less than or equal to 4 to minimize membrane element fouling and extend cleaning intervals. Refer to ASTM Standard D4189

### 2.2 Mounting

E-CE Series machines are equipped with a stand-alone frame, which supports the machine. At least 114 cm (45-inches) of space should be allowed on each end of the

membrane element housings for removal and loading of membrane elements. If 114 cm (45-inches) are not available, the entire membrane element housing may need to be removed for membrane element replacement.

### 2.3 Plumbing

The E4H-CE and E8-CE come with flanged connections installed on all isolation valves.

**Table 2.5  
Connections**

<b>MACHINE</b>	<b>E4H-CE</b>	<b>E8-CE</b>	<b>E8-CE</b>	<b>E8-CE</b>
<b>Model</b>	All Models	9 - 14	17 - 23	28 - 45
<b>Inlet</b>	40 mm	50 mm	80 mm	100 mm
<b>Concentrate</b>	25 mm	40 mm	40 mm	50 mm
<b>Permeate</b>	25 mm	50 mm	50 mm	80 mm

### 2.4 Power and Electrical Requirements

**WARNING: BEFORE OBTAINING ACCESS TO TERMINALS, ALL SUPPLY CIRCUITS MUST BE DISCONNECTED.**

**IMPORTANT NOTE: Motor are dual rated. Factory installed starters and wiring are for 400VAC (380VAC). Motor starter and motor wiring must be replaced prior to converting to lower voltage. Custom Factory Order (CFO) based motors can be rated at other voltages. Check motor for rating.**

The E4H-CE and E8-CE machines are supplied with a single source of incoming power. This power can be 230, 380, 415, 460, or 575 VAC. Check tag on High Voltage Enclosure to verify which voltage is required. The power for control is transformed down from the three-phase power at the main disconnect to 230 single-phase and then down to 24 VDC.

For each model, the motor is wired at the factory to an overload protection motor starter, which is controlled by the panel-mounted Operator Interface Terminal (OIT).



### 3.0 PREPARATION AND START-UP

#### 3.1 Pretreatment for Water Purification

All systems will operate most efficiently on filtered water with a pH of less than 6.5 and a Silt Density Index (SDI) of 5 or below. If the machine is operated on higher pH water, other forms of pretreatment may be necessary. A water analysis prior to start-up of the machine is required. To minimize the chances of calcium carbonate, calcium sulfate, or other salt precipitation on the membrane element, GE Osmonics evaluates each application and water condition and makes specific recommendations to assure continuity of the membrane element warranty. Data from the water analysis is processed with a computer program analysis to determine if potential problems may exist. If the machine is to be run at a different location than was originally intended, a new water analysis is required for warranty considerations and should be sent to GE Osmonics for review and recommendations for operation of the machine.

Before installing the machine, the feed water must be filtered to 5 microns.

Thin-layer composite (TLC) membrane element feed water must not contain the following chemicals or permanent loss of rejection and/or permeate flow may result:

Free chlorine

Formalin (until after membrane element has run for 24 hours, thereafter, 0.5% formaldehyde may be Used as a biocide)

Iodine compounds

Quaternary germicides

Cationic surfactants

Detergents containing non-ionic surfactants

Cleaners not approved by GE Osmonics

**CAUTION:** A water softener should not regenerate while the machine is running unless safeguards are used to be sure the machine is operated on softened water during regeneration.

**NOTE:** To control the RO operation based on water softener regeneration cycle, wire the softener to the Pretreatment Shutdown Control circuit, as described in Field Installed Accessories.

#### 3.2 Initial Start-Up

**NOTE:** If your machine has the membrane elements installed in the housing, proceed to Steps below. If your machine is provided with the membrane elements in shipping boxes, you must load the membrane elements in the housings prior to starting the machine. For membrane element loading instructions, go to Section 4.5 (Membrane Element Installation). Once membrane element installation is complete, return to Step 1 (below) to continue the start-up procedure.

## STEPS

1. Recheck the function and integrity of your pretreatment equipment. Ensure that your water softener, activated carbon filters, and iron filters (where applicable) have been leaked checked, back washed, and thoroughly rinsed for service before starting up your RO unit.
2. Attach the feed water pipe to the inlet of the machine. The standard connection fitting is a polyvinyl chloride (PVC) flanged connection. Refer to Table 2.5 (Connections) for connection sizes.
3. Check for leaks at all connection points.
4. Turn the feed water supply gradually ON and check for leaks in the inlet plumbing.

**NOTE:** When the machine is OFF, there should never be flow through the machine. Flow through the machine when it is OFF can ruin the membrane elements.

5. Attach discharge plumbing to permeate and concentrate outlet points and run the tubing to the drain. The standard connection fitting is a polyvinyl chloride (PVC) flanged connection. Refer to Table 2.5 (Connections).
6. The machine requires one high voltage power source. The motor electrical service must be field wired directly into the motor starter on the machine. Be sure the power to the motor starter is de-energized by turning the disconnect on the high voltage enclosure to the OFF position. The high voltage enclosure can only be opened while in the OFF position. Bring your motor service to terminals labeled "T" on the motor starter. Check the voltage label to ensure you have brought the correct voltage to the starter.

**IMPORTANT NOTE** Motors are dual rated. Factory installed starters and wiring are rated for 400VAC (380VAC). The motor starter and motor wiring must be replaced prior to converting to a lower voltage.

7. Open your concentrate and recycle flow control valves (located behind the control enclosure).

The concentrate valve determines the amount of rejected water leaving the machine and creates the operating pressure shown on the pressure gauge. The recycle valve returns unused reject flow back into the inlet stream to the RO pump. It is important to balance the operating pressure and the respective flows of these valves to ensure that your machine is operating correctly.

It is also important to understand the relationship of these two valves, the pressure gauge, and your RO pump. The pump has a fixed amount of flow produced, and the valves are the control devices to distribute this fixed flow amount. The pressure gauge is an indicator of applied membrane element pressure as the flows set by the valves

8. Press the Fill Button on the OIT so it is in the ON position. Water should begin to flow through the machine at this point, but the pump will not start. Allow the machine to fill for ten (10) minutes.
9. As your machine is filling check for leaks and repair as needed.
10. Turn the ON/OFF switch, located on the High Voltage Enclosure, to the ON position.
11. Energize the power source to the motor starter. The pump should not operate at this point.
12. Check the rotation of the high-pressure pump:

12a Press the RO button so it is in the ON position.

After the minimum inlet pressure [0.8 bar (11.6 psi)] is established and maintained for six (6) seconds, the high-pressure pump will start.

12b When the high-pressure pump starts, immediately press the RO button so it is in the OFF position.

The motor should rotate clockwise while looking at the motor end of the high-pressure pump. If the motor is not rotating clockwise, change any two of the three leads in the motor starter and recheck rotation.

**WARNING: ALWAYS TURN POWER OFF TO CHANGE ANY WIRING.**

**CAUTION:** Operation of the pump backward, even for a short time, can cause damage to the pump.

13. Press the RO button so it is in the ON position. The high-pressure pump will operate and the machine will begin to build pressure.
14. As the machine is operating, watch the primary and final pressure gauges on the instrument panel. The machine is designed to operate at approximately 7.6 bar (110 psi).

**NOTE:** Do not allow the pressure to exceed the maximum boost pressure ( $P_{max}$ ) specified for your machine model (Table 1.2). If the pressure exceeds  $P_{max}$ , open the concentrate and/or recycle control valves until the pressure gauge shows  $P_{max}$  or less.

15. As the machine purges the air and fills with water, the pressure will gradually increase. Water should flow through the permeate and concentrate piping, viewed on the individual flow meters. If you do not see flow, turn the machine OFF and return to Section 3.2 (Initial Start-Up).
16. Gradually adjust the concentrate flow control valve. As you adjust the valve, watch the average pressure ( $P_{avg}$ ) and the your concentrate flow meter. Adjust the valve until your concentrate flow meter displays the desired flow and does not exceed  $P_{max}$ . If  $P_{max}$  is exceeded before the valve is completely closed, open the recycle flow control valve one full turn, then continue to adjust the concentrate flow valve.
17. With the concentrate flow control valve set to obtain the desired concentrate flow and the pressure below  $P_{max}$ , gradually adjust the recycle flow control valve until  $P_{avg}$  reaches 7.6 bar (110 psi). Readjust the concentrate and then the recycle valves, if necessary.
18. Once the desired flow rate is achieved [7.6 bar (110 psi)] operating pressure, no further valve adjustment is needed.

**NOTE:** Permeate flow rates are dependent upon temperature and conditions at your site. Contact your distributor if you have any questions.

The system is now operational.

19. Before putting the machine into final operation, continue to run the permeate and concentrate streams to the drain for at least thirty (30) minutes. This is done to ensure that all the preservative have been removed from the membrane elements.
20. Connect the permeate line to the point-of-use of the permeate. Check for leaks and ensure that you have no kinks in hoses or blockage of any plumbing on the permeate and concentrate outlet lines.
21. Make any final adjustments for flow and pressure, according to Step 18, if needed.
22. Complete and create copies of the Start-Up Log Sheet (Section 7.2). A Daily Log Sheet (Section 7.3), including general operating conditions (pressures, flow, concentrations, pH, and pretreatment conditions) and routine or special maintenance (flushing or cleaning as needed) must be kept. GE Osmonics will require these Log Sheets if a warranty question arises.

### 3.3 Daily Start-Up

Check the machine to insure isolation valves are in the proper positions for operation.

To turn the RO ON, press the RO button so it is in the ON position. If the alarm light is lit, push the “Alarm Reset” switch on the control enclosure and the alarm button on the OIT. If the alarm light stays lit, check the RO for an alarm condition. Otherwise, the main inlet valve will open, and the high-pressure pump will turn on. The high-pressure pump will not start if there is insufficient inlet pressure [ $< 0.8$  bar ( $< 12$  psi)].

## 4.0 MACHINE OPERATION AND MAINTENANCE

The operation and maintenance of a E-CE RO Series machine is relatively simple, but requires regular data recording and routine preventative maintenance. It cannot be emphasized enough the importance of filling out the Daily Log Sheet (Section 7.3) during each operating shift. A Start-Up Data Sheet was completed at start-up (Section 7.2) containing pertinent facts on the operation of your machine. These two records are invaluable in diagnosing the performance of the equipment or warranty issues, and must be kept for reference. If you have questions concerning the operation of your machine or the method of data recording, contact the GE Osmonics Application Engineering Department.

Three preventative maintenance procedures, which must be done on a regular basis, are as follows:

1. Change the pre-filter cartridges.
2. Flush the machine.
3. Clean the machine with approved Osmonics cleaners.

### 4.1 Daily Log Sheets

A Daily Log Sheet, which includes general operating conditions (pressures, flows, and concentrations) and routine or special maintenance (pre-filter changes, flushing, cleaning, etc.) must be kept. Copies of the Daily Log Sheet can be made from the Template (Section 7.3). GE Osmonics will require copies of Daily Log Sheets if a warranty question arises.

### 4.2 Pre-filter Cartridge

A 5 micron pre-filter cartridge is factory installed to protect the membrane elements and valves from particles, which may be in the feed water. To order replacements, see the Spare Parts List (P/N 1233377).

Pre-filter cartridge must be replaced, at a minimum, once per week or after every 100 hours of operation, whichever occurs first. A pressure drop across the filter of 0.6 barg (8.7 psig) or more during operation indicates that the pre-filters cartridge(s) need changing. Use only GE Osmonics approved filters rated for 5 microns or less. Do not attempt to clean used filters. Install new replacements.

**IMPORTANT NOTE:** Failure to change the filter according to these requirements will void machine warranty.

### 4.3 Cleaning

Cleaning the E-CE RO machines on a regular basis is vital. Over time, contaminants build-up to form a layer on membrane element surfaces, reducing the permeate flow and quality. If this build-up is not removed from the membrane element, it may cause permanent chemical damage and reduce membrane element life. A decrease in permeate

flow and/or rejection of salts, or an increased pressure drop across the machine will indicate when cleaning is required. GE Osmonics recommends cleaning at least every month to assure good membrane element performance and long membrane element life.

GE Osmonics offers a full line of chemical cleaners for specific cleaning needs. Refer to the Spare Parts List (P/N 1233377).

To clean membrane elements:

### STEPS

1. The E-CE RO machines do not include a Clean-In-Place (CIP) pump. A CIP pump and tank need to be installed in order to complete the cleaning process. GE Osmonics offers a stand-alone CIP system for the cleaning process. Refer to the Spare Parts List (P/N 1233377).
2. With the E-CE RO machine running, open the CIP permeate valve. After this valve has been opened, close the permeate service valve. Permeate water will flow into the CIP tank. Open the CIP tank drain valve. Allow the water to run through the CIP tank and the CIP drain valve for a few minutes to assure the tank is rinsed thoroughly. Once the tank is rinsed, close the CIP tank drain valve. The CIP tank will begin to fill with RO permeate. When the CIP tank has filled to the indicated full line, press the RO button so it is in the OFF position.
3. With the machine OFF, close the service inlet and concentrate valves and open the CIP inlet and concentrate valves. This will divert permeate and concentrate streams to the cleaning container for recirculation. Insure that the pre-filter is clean. GE Osmonics recommends that you replace the pre-filters prior to cleaning and again replace pre-filters after cleaning. Call GE Osmonics Customer Support Center with questions concerning pre-filter replacement and cleaning.
4. Press the CIP button so it is in the ON position. The cleaning solution should be recirculated for approximately fifteen (15) minutes or until the solution temperature reaches 38°C (100°F). **DO NOT EXCEED 43°C (110°F)**. The membrane elements can only handle temperatures in excess of 29°C (85°F) for short periods of time. If heat rise occurs too quickly, larger volumes of cleaning solution or the use of a heat exchanger will slow the temperature rise. Press the CIP button so it is in the OFF position and allow the machine to soak for ten (10) minutes.

**CAUTION** Do not leave the cleaning strength solution in the machine for a period longer than one hour. The cleaning solution may damage the membrane elements and the machine during an extended period of contact.

5. To flush the detergent from the machine, close the CIP inlet valve, open the service inlet valve, and divert permeate and concentrate to the drain by opening the CIP drain valve. Press the RO ON/OFF button so it is in the ON position to

reestablish normal operation. Operate the machine as described in the flushing section for at least one hour. The detergent is sufficiently flushed when the permeate conductivity is restored to its normal previous level. When conductivity is back to normal, divert the permeate and concentrate back to service positions.

#### 4.4 Draining Machine for Shipment

Prior to shipping or outside storage of a GE Osmonics E-CE RO machine, the system should be cleaned with the appropriate cleaner, flushed with water, and protected from biological attack with the appropriate solution. The membrane element housings and plumbing lines of the machine must be completely drained. Any water remaining in the plumbing may freeze, causing damage to the plumbing, pump, membrane elements, etc. The party shipping or storing the machine is responsible for any damage resulting from freezing.

##### STEPS

1. Disconnect the inlet, concentrate, and permeate outlets.
2. Drain all water from the pre-filter cartridge housing.
3. Remove the tubing connections on the outlets of the membrane element housings.
4. Open the concentrate valve.
5. Open all sample/drain valves.
6. Remove drain plug from pump discharge plumbing.
7. Allow the machine to drain for a minimum of eight (8) hours or until the opened ports quit dripping.
8. After draining is complete, reconnect all of the plumbing.

#### 4.5 Membrane Element Replacement

**CAUTION:** The membrane element is packaged in a small amount of bactericide solution to prevent biological growth; provide adequate ventilation when handling. The membrane element must be kept moist at all times in order to prevent possible damage to the membrane element material.

For machines with membrane elements not loaded at the factory:

##### STEPS

1. Remove the membrane element bag containing the membrane element from the shipping tube.



2. Cut the bag open as close as possible to the seal at the end of the bag, so that the bag may be reused if necessary.
3. Remove the membrane element from the bag and remove the foam protectors from each end of the membrane element.
4. Remove the parts from the parts container (if included) and inspect. Make sure all parts are clean and free of dirt. Examine the O-rings, brine seal, and permeate tube for nicks or cuts. Replace the O-rings or brine seal, if damaged. Set the membrane element aside, in a clean space, and continue on to Step 5.
5. Remove the end caps from both ends of all membrane element housings on your machine. This is done by removing the screws and retaining ring on each end cap closure assembly.
6. Determine the direction of fluid flow in the membrane element housing. (Be certain to look at the “Direction of Flow” arrow on each membrane element housing; they may be different within a given machine.)
7. Inspect the membrane element housing and clean as necessary to remove any contaminants, obstructions, etc.
8. Apply a small amount of O-ring lubricant to all O-rings on the end caps and the brine seal on the membrane element.
9. Insert the downstream end of the membrane element in the upstream end of the membrane element housing (i.e., load in the direction of flow; the brine seal is on the end of the membrane element that goes in last).
10. Insert the membrane element in the membrane element housing with a smooth and constant motion. When you reach the point where the brine seal is about to enter the housing, gently turn the membrane element to ensure that the brine seal enters the housing without coming out of the brine seal groove.
11. When all of your membrane elements are installed, close the membrane element housing by reinstalling the end caps and clamps. It is preferred to install the bottom end cap first and tighten the clamp completely before installing the top end cap.
12. Reinstall the end caps by gently twisting the end cap while pushing it on to the permeate tube. Insure that you do not pinch or fatigue any O-rings while pushing the end cap on. Push the end cap on until the outer diameter of the cap passes the retaining ring groove. Install the retaining ring screws.
13. Reconnect any fittings that were removed when disassembling the membrane element housings.
14. Return to Initial Start-Up (Section 3.2).

#### 4.6 Membrane Element Removal

As time progresses, the efficiency of the membrane element will be reduced. In general, the salt rejection does not change much until two or three years after installation, when operated on properly pretreated feed water and routine maintenance performed. The permeate flow rate will begin to decline slightly after one year of operation, but can be extended with diligent flushing and cleaning of the machine. High pH feed water and/or precipitation of hardness can cause premature loss in rejection and even flow rate. The following procedure is to be followed to replace existing membrane elements in the machine.

##### STEPS

1. Remove the end caps and clamps from all the membrane element housings.
2. Remove all the membrane elements from the membrane element housings in the direction of flow (where possible). If necessary, a membrane element can be removed against the direction of flow. Heavy-duty pliers or channel-lock pliers may be necessary to pull the old membrane element out of the membrane element housing.
3. To reinstall replacement membrane elements, see Section 4.5 (Membrane Element Replacement).

**NOTE:** Follow Membrane Element Specifications (Table 1.3).

**NOTE:** Do not allow the machine to freeze unless it is totally drained. It must thaw a minimum of 24 hours before starting.

## 5.0 FIELD INSTALLED ACCESSORIES

### 5.1 Pretreatment Shutdown

E-CE Series RO machines are equipped with Pretreatment Shutdown control capability. Pretreatment Shutdown is the ON/OFF control of the RO via a signal from a remote device. External Control can be used when Permeate Flush is not desired prior to RO shutdown (Permeate Flush, Section 5.2). The Permeate Shutdown control could be remote ON/OFF, level control, pretreatment lockout, and/or post-treatment lockout, etc. Utilization of this feature requires a customer-wired control loop, wired to factory-supplied terminals. This procedure is as follows:

**WARNING: BEFORE OBTAINING ACCESS TO THE TERMINALS, ALL SUPPLY CIRCUITS MUST BE DISCONNECTED.**

#### STEPS

1. Establish that the remote device(s) have dry contacts available to provide the shutdown signal to the RO. Ensure that the normal mode of contact is such that it opens when shutdown is desired.
2. With power removed from control enclosure, open enclosure.
3. Wire from the 24VDC source terminal #514 to the first remote device. Wire all additional devices in series with the first. Wire the last remote device to terminal #1006.
4. On the OIT, press the “Auto/Hand” button located under the RO button. Make sure it is in the Auto position.

With multiple remote devices wired in series, as described above, an open contact from any of the configured devices will activate the External Control Shutdown.

### 5.2 Permeate Flush

Permeate Flush is designed into the E-CE-RO machines to provide an integral means of reducing the fouling potential of the stagnant concentrate in the RO during extended periods after automatic shutdown. The E-CE-RO machines are equipped with the necessary plumbing and electrical controls to provide a 10-minute pure water (permeate) flush. Activation of the purge cycle by remote device requires a customer-wired control loop to factory supplied terminals. This procedure is provided later.

A second way to perform permeate purge is by manually pressing the Permeate Purge button on the OIT screen.

The purge cycle is activated by a shutdown signal received from an external device wired to the RO. Upon activation of the Purge Cycle, the machine remains in run mode and the permeate stream is redirected to the inlet of the machine. The feed water is diluted by an amount proportional to the operating recovery of the machine. The net result, after con-

centration of the diluted feed stream, at the operating recovery, is that the water in the machine at shutdown will have total dissolved solids (TDS) concentrations approximately equal to the machine feed TDS level. The low TDS environment created reduces the potential for membrane element fouling during the down period, extending membrane element life. The purge operates for a ten (10) minute period. During this period, no permeate is discharged from the machine and concentrate flows from the machine at the normal operating rate. When the cycle is complete, the RO pump will shut down. When the request to restart is received, the RO will restart and operate as normal. If the restart signal is received during the Purge Cycle, the cycle will terminate and the RO will return to normal operating mode.

Since this feature is designed to provide a low TDS environment during extended shutdown periods, the purge sequence will not activate for any factory-configured shutdown event (i.e., ON/OFF switch, alarm shutdown, etc.). These shutdown events are assumed to be typically short down periods. Also, activation of the purge cycle for these events may be undesirable if immediate shutdown is required. The purge cycle will activate when a shutdown request is made by an external component that is configured for purge-activated RO shutdown.

Level control of a permeate storage tank is GE Osmonics' standard external control device which activates the purge shutdown. Any other remote device(s) can be used where permeate purge is desired prior to RO shutdown. Examples include: remote ON/OFF, post-treatment lockout, etc.

**WARNING: DO NOT CONFIGURE PRETREATMENT DEVICES FOR PURGE-ACTIVATED SHUTDOWN. THE PURGE CYCLE REQUIRES THE FEED WATER SUPPLIED BY THESE DEVICES.**

To establish the control loop for purge-activated shutdown, perform the following steps:

**WARNING: BEFORE OBTAINING ACCESS TO TERMINALS, ALL SUPPLY CIRCUITS MUST BE DISCONNECTED.**

#### STEPS

1. Establish that the remote device(s) has dry contacts available to provide the shutdown signal to the RO.
2. With power removed from the control enclosure, open enclosure.
3. Wire from the 24VDC source terminal #515 to the first remote device. Wire all additional devices in series with the first. Wire from the last remote device to terminal #1007.

4. Turn the AUTO/HAND Button on the Purge Button located on the OIT to the “AUTO” position.

With multiple remote devices wired in series, as described above, an open contact from any of the configured devices will activate the Permeate Purge Cycle.

### 5.3 Chemical Pump

GE Osmonics offers a stand-alone chemical pump and tank that can be used to control the pH of the RO system. Refer to the Spare Parts List (P/N 1233377) for ordering information.

### 5.4 Clean-In-Place Installation

GE Osmonics has installed a flange connection in the inlet line of the E-CE RO machines. Refer to Table 2.5 (Connections) for connection sizes. Valved Clean-In-Place (CIP) connections are provided on permeate and concentrate outlets to allow flow back to the cleaning tank. GE Osmonics offers a stand alone CIP system, refer to the Spare Parts List (P/N 1233377).

## 6.0 TROUBLESHOOTING

This troubleshooting guide can assist you in identifying common operating problems you may experience with your machine. The operator can easily correct many of these problems, however, for those that persist or are not understood you should contact the GE Osmonics Customer Support Center. Have the following information available when calling the Customer Support Center:

1. Machine installation date
2. Model number
3. Serial number
4. Detailed description of problem

### TROUBLESHOOTING

SYMPTOM	POSSIBLE CAUSES	REMEDIES
<b>Low operating pressure</b>	Insufficient feed water pressure flow	Open the feed pressure, open the feed water valve, and check for restrictions.
	Clogged pre-filter	Replace pre-filter cartridge.
	High flow rates	Close the concentrate valve, check the permeate and concentrate flow rates and adjust if necessary. Excessive permeate flow may indicate a damage O-ring.
	Dirty or fouled membrane elements	Flush and clean the membrane elements.
	Solenoid valve not opening	Clean or replace the solenoid valve.
	Pump rotating backwards (three-phase power only)	Switch any two three-phase leads to the motor starter.

## TROUBLESHOOTING

SYMPTOM	POSSIBLE CAUSES	REMEDIES
<b>Low operating pressure (continued)</b>	Insufficient electrical power	Check the fuses or circuit breakers; measure the voltage.
	Pump not operating correctly	See Tonkaflo pump instructions.
<b>Low permeate flow rate</b>	Low operating pressure	See possible causes for low pressure.
	Dirty or fouled membrane elements	Flush and clean the membrane elements.
	Operating on cold water less than 13°C (55°F)	Install a hot/cold feed water tempering valve if more permeate flow is needed. Operate with a feed water temperature of 22° - 25°C (72° -77°F).
	Membrane elements installed backward or damaged concentrate seal	Install membrane elements in the direction of fluid flow. Flush and clean the machine <u>immediately</u> . Membrane elements with damaged seals should be cleaned and may be returned for repair.
	Flow meter inaccurate	Check the flow rate manually with a stopwatch and calibrated container.

## TROUBLESHOOTING

SYMPTOM	POSSIBLE CAUSES	REMEDIES
<b>Low permeate flow rate (continued)</b>	Operating on cold water less than 13°C (55°F)	Install a hot/cold feed water tempering valve if more permeate flow is needed. Operate with a feed water temperature of 22° - 25°C (72° -77°F).
	Membrane elements installed backward or damaged concentrate seal	Install membrane elements in the direction of fluid flow. Flush and clean the machine <u>immediately</u> . Membrane elements with damaged seals should be cleaned and may be returned for repair.
<b>Low concentrate flow rate, normal or higher than normal pressure</b>	Concentrate valve plugged	Remove the concentrate valve and/or disassemble the plumbing. Clean the valve.
	Concentrate outline line restricted	Examine the concentrate line for obstructions or kinks, repair or replace the tubing.
	Flow meter inaccurate	Check the flow rate manually with a stopwatch and calibrated container.
	Dirty concentrate valve	Disassemble and clean the plumbing to the valve.



## TROUBLESHOOTING

SYMPTOM	POSSIBLE CAUSES	REMEDIES
<b>High operating pressure</b>	Recycle or concentrate valve plugged	Disassemble the plumbing to the recycle valve and remove foreign particles. Check the concentrate valve stem.
	Inaccurate pressure gauge	Replace or calibrate the gauge as required.
	Restricted flow after pump outlet	Check for blockage of the concentrate flow at the inlets and outlets of the membrane element housings.
	Telescoped membrane element covering membrane element housing outlet port	Ensure that the anti-telescoping device (ATD) is located properly on the membrane elements.
<b>Water flowing when machine is turned OFF</b>	Inlet solenoid valve not closing or seating properly  Severely fouled or dirty membrane elements	Clean or replace the valve. Clean the membrane elements with detergent <u>immediately</u> . Water must not pass through the inlet when the machine is OFF.
<b>Declining rejection (high permeate conductivity)</b>	Dirty or fouled membrane elements	Flush and clean the membrane elements.

## TROUBLESHOOTING

SYMPTOM	POSSIBLE CAUSES	REMEDIES
<b>Declining rejection (high permeate conductivity) (continued)</b>	O-ring seal broken or damaged	Replace O-ring, check the sealing surfaces on the O-ring groove, interconnectors and end caps. Replace damaged parts.
	Change in incoming water quality	Open the concentrate valve and flush. Test the water for pH, hardness, TDS, and iron content. A water analysis should be sent to GE Osmonics for review.
	Inaccurate conductivity monitor or fouled probe	Calibrate the monitor with a DS standard solution or check the readings with another conductivity meter. Replace or clean the probe. Check the connections between the probe and monitor.
<b>Machine not operating</b>	Pressurized storage switch or float switch has cut power to machine	Check the permeate back pressure or position of float in the storage tank.
	External control or permeate purge control contacts have shut machine down	Check for proper orientation of control contacts. Restart machine manually or wait for automatic start-up.

## TROUBLESHOOTING

SYMPTOM	POSSIBLE CAUSES	REMEDIES
<b>Machine not operating (continued)</b>	Thermal overload in motor has tripped	Allow the machine to cool: check the feed water supply and/or amp draw to the motor.
	No power to machine	Check the fuses or circuit breakers, measure the voltage.
	Motor and/or pump not operating properly	See Tonkaflo pump instructions. Contact GE Osmonics for possible repair or replacement.
	Alarm condition has turned OFF machine	Check for minimum inlet pressure and push alarm reset switch.
<b>Electrical machine shut down</b>	Alarm condition has turned OFF machine	Restart the machine by pushing the alarm bypass. Check for possible alarm conditions: inlet pressure or motor starter overload.
	External control or permeate purge control contacts have been shut machine down	Check for proper orientation of control contacts. Restart machine manually or wait for automatic start-up.

## TROUBLESHOOTING

SYMPTOM	POSSIBLE CAUSES	REMEDIES
<b>Electrical machine shut down (continued)</b>	Motor starter overloaded, heater tripped.	Turn the switch OFF; let the heater(s) cool.
<b>Conductivity drifts or changes after calibration</b>	Calibration may have been done before the reading stabilized	When calibrating, wait at least 15 seconds to 1-1/2 minutes for reading to stabilize.
	The stable line may contain electrical noise	To reduce electrical noise, use grounded metal fittings on the inlet and outlet of the monitor plumbing.
	Turbine meter not spinning	Check meter for spin.
<b>Display is blank</b>	Monitor not powered	Open the front panel. Look at the yellow LEDs on the rear power board. Are they ON? If yes, check ribbon cable. Is it properly seated? If no, does the unit have power?
<b>pH reading is off by more than 1pH unit</b>	Probe calibrated using span or the pH probe is bad	Re-initialize calibration. Recalibrate using zero only. Replace pH sensor.

### TROUBLESHOOTING

<b>SYMPTOM</b>	<b>POSSIBLE CAUSES</b>	<b>REMEDIES</b>
<b>Chemical pump will not feed chemical</b>	Pumping may be affected by other software variables	Is the relay turned ON or OFF? Is the CIP input activated? You must have permeate or concentrate flow for a relay configured as a set point to function and trigger the pump.
<b>Chemical pump feed reverse of what you expected</b>	Relay set point not properly configured	Determine whether you need the relay configured for direct or reverse set point feed.

## 7.0 FORMS

### 7.1 RETURN GOODS AUTHORIZATION (RGA)

If you wish to return goods for repair, warranty evaluation and/or credit, please have your original sales order or invoice available when you call GE Osmonics. Call GE Osmonics at (800) 848 - 1750 and ask to speak with Customer Service. A GE Osmonics Customer Service representative will provide instructions and a return goods authorization number, which needs to be clearly written on the outside of the box used to ship your materials. All equipment must be shipped to GE Osmonics with the freight prepaid by the customer. Call our Customer Service Center with any questions or issues concerning freight claims and a representative will discuss your situation.

All materials to be returned must be rendered into a non-hazardous condition prior to shipping.

# E - S E R I E S S T A R T - U P   D A T A   S H E E T

<b>Customer:</b> _____ <b>Date:</b> _____			
<b>Model Number:</b> _____ <b>Tested By</b> _____			
<b>Serial Number:</b> _____			
Units (Circle One)	Data	Data	Remarks
<b>Permeate Rate</b>			
<b>Total Flow Rate</b>			
<b>Pre-Filter Pressure</b>			
<b>Post-Filter Pressure</b>			
<b>Primary Pressure</b>			
<b>Final Pressure</b>			
<b>Feed TDS</b>			
<b>Concentrate TDS</b>			
<b>Avg TDS</b>			
<b>Permeate TDS (manual)</b>			
<b>Permeate TDS (meter uS)</b>			
<b>% Passage (Perm TDS/Avg TDS)</b>			
<b>Chlorine in Concentrate</b>			
<b>Low Pressure Pressure Switch Setting</b>			

NOMENCLATURE

- PRESS = PRESSURE  
 CONC = CONCENTRATE (BLOW-BY)  $Q_c$   
 PERM = PERMEATE (PURE WATER)  $Q_p$   
 RESIST = RESISTANCE  
 TEMP = TEMPERATURE  
 RECY = RECYCLE  
 COND = CONDUCTIVITY

# E-SERIES DAILY LOG SHEET

NAME OF COMPANY \_\_\_\_\_

MACHINE MODEL NO.: \_\_\_\_\_

SERIAL NO.: \_\_\_\_\_

**NOTE:** Please record all calibrations of instruments or other occurrences related to this system.

<i>DATE AND TIME</i>																			
<b>PRE-FILTER PRESS (psi or bar)</b>																			
<b>POST-FILTER PRESS (psi or bar)</b>																			
<b>PRIMARY PRESS (psi or bar)</b>																			
<b>FINAL PRESS (psi or bar)</b>																			
<b>TEMP (°F or °C)</b>																			
<b>PERM FLOW (gpm or m<sup>3</sup>/h) <math>Q_p</math></b>																			
<b>CONC FLOW (gpm or m<sup>3</sup>/h) <math>Q_c</math></b>																			
<b>RECOVERY: <math>Q_p / (Q_p + Q_c)</math></b>																			
<b>FEED COND (mS) <math>C_f</math></b>																			
<b>CONC COND (mS) <math>C_c</math></b>																			
<b>AVG COND (mS) <math>(C_f + C_c) / 2</math></b>																			
<b>PERM COND (mS) <math>C_p</math></b>																			
<b>FILTER CHANGE (✓) &amp; TYPE</b>																			
<b>CLEAN (✓)</b>																			
<b>FEED CHLORINE (ppm)</b>																			
<b>FEEDWATER HARDNESS (gpg or ppm)</b>																			
<b>OPERATOR'S INITIALS</b>																			

This is a template. Make copies as needed.  
 \*Symbols: Q - Flow Rate; C - Conductivity  
 Reference the Troubleshooting Guide in your Instruction Manual where trends or differences are noted.

**PERIOD OF THIS SHEET \_\_\_\_\_ TO \_\_\_\_\_**



## 8.0 WARRANTY

### 8.1 Warranty Terms

Subject to the terms and conditions set forth hereinafter, Seller (GE Osmonics, Inc. or any of its authorized subsidiaries) warrants to the original purchaser (hereafter the “Buyer”) that the products manufactured by Seller are free from defects in material and in workmanship for twelve (12) months from the Warranty Commencement Date (as defined below) only when used strictly in accordance with the applicable operating instructions and within the range of the operating conditions specified by Seller for each such product. This Warranty does not extent to equipment or components manufactured by others into which a Seller product has been incorporated or to equipment or components which have been incorporated into a Seller product but, if allowable, Seller hereby assigns, without warranty, to the Buyer its interest, if any, under any warranty made by the manufacturer of such equipment or component. This Warranty does not cover disposable items such as fuses, lamps, filters, cartridges, or other such disposable items, which must be replaced periodically under the normal and foreseeable operating conditions of the goods warranted hereby.

### 8.2 Warranty Commencement Date

The Warranty Commencement Date for each Seller product shall be the later of the date of: (1) receipt by the Buyer, or (2) the date of installation at the Buyer’s premises provided that such installation must occur within three (3) months of shipment from the Seller’s manufacturing facility in Minnetonka, Minnesota. In no event shall the Warranty Commencement Date exceed three (3) months from the shipment from the Seller’s manufacturing facility. The Buyer shall provide proof of purchase in order to exercise rights granted under this Warranty. If requested by Osmonics, the Buyer must also provide proof of the installation date. Proof of installation shall be returned by Buyer to Seller within thirty (30) days after installation by virtue of supplying a Warranty Validation Card supplied with each Seller product fully completed and signed in ink by Buyer and the authorized installer of the product.

### 8.3 Warranty Service

SELLER’S OBLIGATION UNDER THIS WARRANTY IS LIMITED TO REPAIR OR REPLACEMENT (AT SELLER’S SOLE OPTION) OF ANY PRODUCT, OR COMPONENT THEREOF, PROVED TO BE DEFECTIVE IN MATERIAL OR WORKMANSHIP WITHIN THE COVERED WARRANTY PERIOD. The Buyer, at the Buyer’s risk and expense, shall be responsible for returning such product or component, upon obtaining a Return Goods Authorization (RGA) number from the Seller, freight prepaid, and in conformance with any special packaging and shipping instructions set forth on the operation documentation or RGA instructions, or as otherwise reasonably required, to the Seller’s address set forth below, together with (1) RGA number issued by Seller at Buyer’s request; (2) proof of purchase and, if necessary, proof of installation date; (3) a description of the suspected defects; (4) the serial number of the Seller product alleged to be defective; and (5) a description of the type of water pretreatment equipment which has been utilized in connection with the product, if any. Seller shall, in Seller’s reasonable

discretion, be the sole judge of whether a returned product or component is defective in material or workmanship. Required or replaced products or components shall be returned freight. In genuine emergency situation, Seller will (at Seller's sole option) forward replacement parts to Buyer without waiting for authorized return of the questionable part(s). In such cases, Buyer will issue a purchase order or other payment guarantee prior to shipment. If the returned part is found to have been misused or abused, the defective part is not received by Seller within thirty (30) days, the Buyer will be invoiced for replacement part(s) provided. This Warranty does not cover or include labor and/or travel to the Buyer's premise or location or any other location. Charges will be made for the usual and customary Seller costs and associated expenses incurred by Seller in providing Warranty Service at any location other than Seller's factory at the address set forth below, and Seller reserves the right to precondition such travel to Buyer's premises upon prepayment of Seller's anticipated costs of attending such premises.

#### 8.4 Voidability of Warranty

This Warranty shall be void and unenforceable as to any Seller product which has been damaged by accident, mishandling, abuse or has been repaired, modified, altered, disassembled or otherwise tampered with by anyone other than Seller or an authorized Seller service representative; or, if any replacement parts are not authorized by Seller have been used, or, the product has not been installed, operated and maintained in strict accordance and adherence with the operating documentation and manuals for such product. Any express warranty, or similar representation of performance set forth in the operation documentation for a reverse osmosis or ultrafiltration membrane incorporated into a Seller product shall be void and unenforceable unless the feed water requirements set forth in the operating documentation for such product are unequivocally and strictly adhered to.

#### 8.5 Limitations and Exclusions

THIS WARRANTY AND REMEDIES DESCRIBED HEREIN AND HEREINABOVE ARE EXCLUSIVE AND IN LIEU OF ANY AND ALL OTHER WARRANTY OR REMEDIES, EXPRESSED OR IMPLIED, INCLUDING WITHOUT LIMITATION, ANY IMPLIED WARRANTY OF MERCHANTABILITY OR FITNESS FOR A PARTICULAR PURPOSE. IN NO EVENT SHALL THE SELLER BE LIABLE FOR ANY CONSEQUENTIAL, INCIDENTAL OR OTHER SIMILAR TYPES OF DAMAGES, OR FOR DAMAGES FOR THE LOSS OF PRODUCTION OR PROFITS, OR INJURY TO PERSON OR PROPERTY. NO PERSON HAS ANY AUTHORITY TO BIND SELLER TO OTHER THAN WHAT IS SET FORTH ABOVE.

THIS WARRANTY GIVES THE BUYER SPECIFIC LEGAL RIGHTS AND THE BUYER MAY ALSO HAVE OTHER RIGHTS WHICH VARY FROM JURISDICTION TO JURISDICTION. THE PARTIES RECOGNIZE AND AGREE, THAT IN ALL RESPECTS THE LAWS OF THE STATE OF MINNESOTA SHALL APPLY TO AND SHALL GOVERN ANY INTERPRETATION OR LEGAL SIGNIFICANCE OF THIS DOCUMENT.

NO WARRANTY OR OTHER LIABILITY OF SELLER TO BUYER UNDER THIS AGREEMENT OR OTHERWISE WILL IN ANY EVENT EXCEED THE COST OF REPLACEMENT OF THE APPLICABLE SELLER PRODUCT, PART, OR ACCESSORY THAT IS SUBJECT TO ANY BREACH OF SELLER'S WARRANTY. SELLER WILL NOT BE LIABLE FOR ANY DAMAGE TO ANY PROPERTY OF BUYER OR TO BUYER'S CUSTOMERS FOR ANY CONSEQUENTIAL, INCIDENTAL, OR ECONOMIC LOSS OR COMMERCIAL DAMAGE WHATSOEVER. REMEDIES HEREIN PROVIDED ARE EXPRESSLY MADE THE SOLE AND EXCLUSIVE REMEDIES FOR BREACH OF ANY WARRANTY OR OTHER OBLIGATION HEREUNDER EXPRESS OR IMPLIED OR FROM THE OPERATION OF LAW.

Any questions about this Warranty and all warranty service returns should be addressed to:

**GE OSMONICS, INC.**  
Minnetonka Operations  
Attn: Customer Service Center  
5951 Clearwater Drive  
Minnetonka, MN 55343 USA



Call (952) 933-2277 for additional information, (800) 766-2599 in the U.S., or visit [www.osmonics.com](http://www.osmonics.com)

Manufactured in the USA



**GE Osmonics**

Corporate Headquarters

5951 Clearwater Drive  
Minnetonka, MN  
55343-8995  
USA  
(952) 933-2277 Phone  
(952) 933-0141 Fax

Euro/Africa Operations

230 rue Robert Schuman  
ZA des Uselles  
F-77350 Le Mœe sur Seine  
FRANCE  
+33 1 64 10 2000 Phone  
+33 1 64 10 3747 Fax

Asia/Pacific Operations

1044/8 SOI 44/2  
Sukhumvit Road Prakanong  
Bangkok 10110  
THAILAND  
+66 2 38 14213 Phone  
+66 2 39 18183 Fax