



# MRS 100/225/225CC Reverse Osmosis System

Configurable system that delivers reverse osmosis or blended water for multiple foodservice applications



- |                  |           |
|------------------|-----------|
| MRS-100 System   | EV9970-07 |
| MRS-225 System   | EV9970-08 |
| MRS-225CC System | EV9970-09 |
| PRE-FILTER KIT   | EV9795-81 |
| 6TO-BW Cartridge | EV9607-41 |
| MR-100 Cartridge | EV9627-11 |
| MR-225 Cartridge | EV9627-03 |
| 7CC-BW Cartridge | EV9627-05 |

## BENEFITS

- Improves equipment life and performance by removing at least 90%+ of all dissolved solids that cause scale build-up
- Protects against taste and odor causing contaminants while removing dirt, particulates and dissolved minerals
- Less frequent deliming of equipment means reduced maintenance and service costs
- Sanitary cartridge replacement is simple, quick and clean. Internal filter parts are never exposed to handling or contamination
- Wall mount design allows flexible installation
- Reduces chlorine taste and odor and other offensive contaminants that can adversely affect taste of water and beverages
- Reduces limescale build-up that can cause excessive machine downtime and increased maintenance costs. Plus, scale reduction reduces energy costs

## INSTALLATION TIPS

- Choose a mounting location suitable to support the full weight of the system when operating
- Deliming of equipment prior to application is recommended
- Never use saddle valve for connection
- Use 3/8" (min.) water line
- The water inlet must supply a minimum of 0.5 gpm
- Install vertically with cartridge hanging down and allow 2 inches above and below unit for cover removal and service access.
- Allow clearance to right of unit for optional pre-filter
- Refer to Installation, Operation & Maintenance Manual for cartridge flushing and RO start-up

## OPERATION TIPS

- Change filter cartridges on a regular 6 month preventative maintenance program
- Change RO cartridges on a regular 2 year preventative maintenance program
- Change cartridges when capacity is reached
- Always flush the filter cartridge at time of installation and cartridge change

## APPLICATION/SIZING

- Mineral Reduction System for foodservice applications
- Ideal for: Flash steamers, conventional steamers, cheese melters, combi-ovens and coffee/espresso machines
- Output capacity dependant on membrane selected:
  - 100 gallons per day (379 lpd)
  - 225 gallons per day (852 lpd)
- For use in coffee, steam, reconstitution, ice and multiple applications.

# MRS 100/225/225CC

## SPECIFICATIONS

**Overall Dimensions:**  
30"H (34"-CC Model) x 15"W (20.5"  
with Prefilter) x 8"D

**Inlet and outlet connection:**  
3/8" OD tube connection

**Wastewater line connection:**  
1/4" OD tube connection

**Service Flow Rate:**  
Dependant on water pressure in storage tank  
and line size (s) to equipment

**Pressure Requirements:**  
**Operating:**  
25 - 80 psi (1.7 - 5.5 bar), non-shock  
**Maximum Static:**  
100 psi (6.9 bar), non-shock

**Electrical connection required:**  
115 Volts AC, 60 Hertz, 1 Phase

**Water Supply:**  
0.5 gpm (1.9L) @ 50-85 psi (280-595 Kpa)

**Inlet Temperature:**  
40°F - 100°F (4-38°C)

**Inlet TDS:**  
1,500 ppm max recommended

**Operating Weight:** 35 lbs.  
(not including storage tanks)

The contaminants or other substances removed or reduced by this system are not necessarily in your water. Do not use with water that is microbiologically unsafe or of unknown quality without adequate disinfection before or after the system.

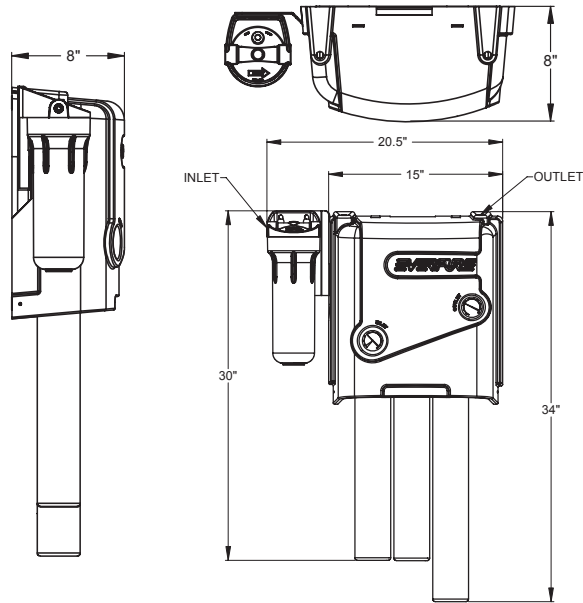

## WARRANTY

MRS 100/225/225CC system (excluding replaceable elements) is covered by a limited warranty against defects in material and workmanship for a period of one year after the date of purchase. Everpure replaceable elements (filter cartridges and water treatment cartridges) are covered by a limited warranty against defects in material and workmanship for a period of one year after date of purchase. See printed warranty for details. Everpure will provide a copy of the warranty upon request.



Everpure offers a full line of water storage tanks. Contact your Everpure sales representative for more information.

### EVERPURE®

EVERPURE, LLC  
1040 Muirfield Drive  
Hanover Park, Illinois 60133  
Toll Free (800) 323-7873  
Tel. (630) 307-3000  
Fax (630) 307-3030  
<http://www.everpure.com>

*In Europe:*  
EVERPURE EUROPE B.V./B.A.  
INDUSTRIEPARK WOLFSTEE  
TOEKOMSTLAAN 30  
B-2200 HERENTALS  
BELGIUM  
TEL 32-14-283500  
FAX 32-14-283505

*In Japan:*  
EVERPURE JAPAN LLC  
HASHIMOTO MN BLDG. 7F  
3-25-1 HASHIMOTO SAGAMIHARA-SHI  
KANAGAWA 229-1103  
JAPAN  
TEL 81-(0)42-775-3011  
FAX 81-(0)42-775-3015

Everpure  
1040 Muirfield Drive  
Hanover Park, IL 60133  
Phone: 630-307-3000 Fax: 630-307-3030