

Complete Store Water Quality Systems



Model EQHP-TWIN 70L
Water Quality System

Features

70,000 Gallon Water Quality System

Water filtration system for high flow-rate and capacity environments

- System includes a two-cartridge manifold with built-in pressure gauge, inlet water shut off valve, outlet check valve, mounting brackets and two EQHP-35L cartridges.
- Consistent great-tasting brewed coffee and tea from water with reduced sediment and chlorine taste and odor.
- Incorporates multi-zone pharmaceutical grade pleated nylon pre-filter.
- Pre-filter offers exceptional sediment holding capacity and particle reduction to 0.2 microns.
- Equipment protection from reduced sediment particles that can clog the sprayhead.
- NSF Standard 42 and/or FDA CFR-21 compliance provides assurance of safety.
- Certified by NSF to Standard 53 for cyst reduction.
- Reduced scale formation by the controlled release of proprietary scale inhibitors as tested by the manufacturer.
- Patented Quick Connect Head uses encapsulated cartridge design allowing for fast and easy change-outs with a 1/4 turn while minimizing the possibility of leakage and contamination.
- Auxiliary inlet gauge port allows optional monitoring of differential water pressure.
- Filter cartridges incorporate carbon block media and require no pre-activation
- 3/4" FNPT horizontal inlet and outlet ports allow direct or easily adaptable connections to existing plumbing lines.
- System maximum operating pressure is 100 psi (862 kPa) and operating temperature 100°F (38°C).

For current specification sheets and other information, go to www.bunn.com.

Related Products

Replacement Cartridge

EQHP-35LCRTG

Product No.: 39000.1011

Twin Manifold

EQHP-Twin

Product No.: 39000.0105

Model

EQHP-TWIN70L

Agency Listing



Patents Apply

8/08

F16

Dimensions & Specifications

Model	Product #	Service Flow Rate & Capacity	Micron Rating	Application
High Volume				
39000.0012	EQHP-TWIN70L	6.68 gpm/70,000 Gallons	0.2	Complete store system needing 70,000 gallon usage per 6 months.

Note: Inlet and outlet plumbing connections are 3/4" FNPT.

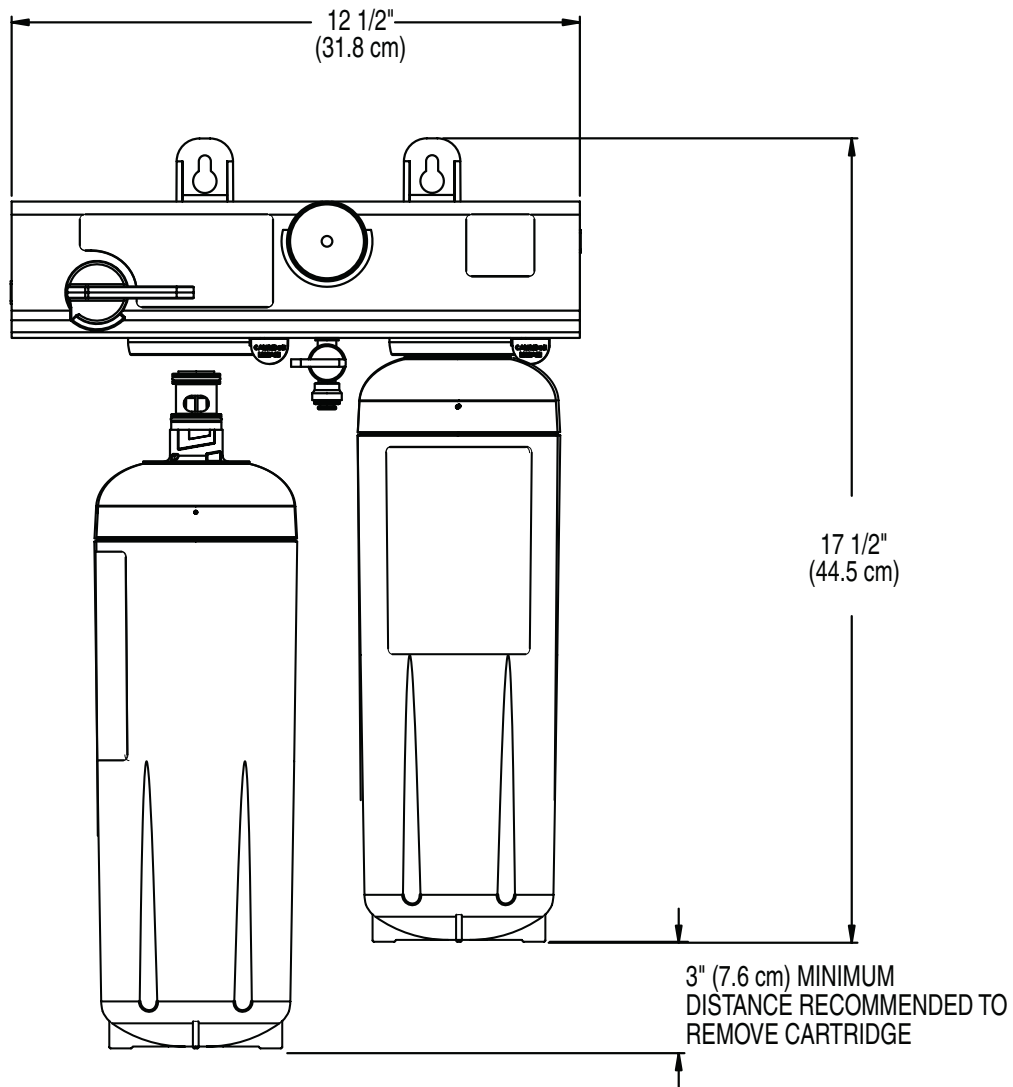

Bunn-O-Matic® Corporation - 1400 Stevenson Drive Springfield, Illinois 62703 • 800-637-8606 • 217-529-6601 • Fax 217-529-6644 • www.bunn.com

BUNN® practices continuous product research and improvement. We reserve the right to change specifications and product design without notice. Such revisions do not entitle the buyer to corresponding changes, improvements, additions or replacements for previously purchased equipment.

All dimensions shown in inches.

8/08 © Bunn-O-Matic Corporation