

WaterMaker^{FIVE}

5-Stage Reverse Osmosis System
WM5-50



41840 McAlby Court, Suite A
Murrieta, CA 92562
800-451-9343, FAX 951-894-2801
www.nimbuswater.com

WaterMaker^{FIVE}

Introduction to the WaterMaker Five

Congratulations on your purchase of the WaterMaker Five reverse osmosis system. When properly maintained, this system will provide you with years of trouble-free service. The next sections contain important information on the proper care and maintenance of your system, please take a few minutes to read through this information.

The cartridges in this system must be replaced on a regular basis to maintain efficiency and to safeguard water quality. These cartridges work together to remove potential contaminants from your tap water and must be replaced every 6-12 months. Any significant change in performance of the system should be investigated promptly to avoid secondary damage or deterioration to other parts of the system.



The WaterMaker Five uses the latest in system design and membrane technology to reduce the amount of water down the drain by 25%.

The WaterMaker Five is smaller and uses significantly fewer resources in the manufacturing process than the typical 5-stage RO system.

Smaller packaging and a lighter shipping weight further reduce impact on the environment.

Stage	Description	Replacement Interval	Part Number
1-4	4-Stage Cartridge 1) 20 micron sediment prefilter 2) Granular activated carbon (GAC) prefilter 3) Reverse osmosis membrane 4) Granular activated carbon postfilter	12 months	104592
5	Granular activated carbon (GAC) postfilter (between tank and faucet)	6-12 months	104803

WaterMaker^{FIVE} Warranty

The Limited Warranty extends to the original purchaser of the system. This warranty covers all parts and factory labor needed to repair any Manufacturer-supplied item that proves to be defective in material, workmanship or factory preparation. The above-mentioned warranty applies for the first full calendar year from date of purchase. These defective items are subject to the following exclusions: membranes, filters, O-rings, and all other parts or components that require regular replacement as a result of ordinary usage.

Disclaimers This Warranty applies only if the system is installed and used in compliance with the instructions enclosed with the system.

This Warranty does not cover the costs of repairs or adjustments to the unit that may be needed because of the use of improper parts, equipment or materials. This Warranty does not cover repairs required due to unauthorized alterations of the unit, or failure of a unit caused by such alterations or by unauthorized repairs.

The Warranty does not cover malfunctions of the unit due to tampering, misuse, alteration, lack of regular maintenance, misapplication, fouling due to hydrogen sulfide or iron, scaling from excessive hardness, turbidity greater than 1.0 NTU, Silt Density Index (SDI) greater than 5.0 SDI, or excessive membrane hydrolysis due to chlorine levels in excess of 0.5 ppm. In addition, damage to the unit due to fire, accident, negligence, act of God, or events beyond the control of the Manufacturer are not covered by this warranty.

Incidental and Consequential Damages The Manufacturer does not assume responsibility for payment of incidental and consequential damages as a result of the failure of this unit to comply with express or implied warranties, such as lost time, inconvenience, damage to personal property, loss of revenue, commercial losses, postage, travel, telephone expenditures, or other losses of this nature. Some states do not allow the exclusion or limitation of incidental or consequential damages, so this exclusion may not apply to you.

Owner's Warranty Responsibilities Under the provisions of the Warranty, the owner is expected to schedule maintenance, as described in this Manual. Neglect, improper maintenance, abuse, or unapproved modifications may invalidate the Warranty. Should your unit develop a defect or otherwise fail to perform in accordance with this warranty, you should contact the dealer from whom the product was originally purchased.

Implied Warranties The implied at-law warranties of merchantability and fitness for a particular purpose shall terminate on the date one year after the date of purchase. Note: some states do not allow limitations on how long an implied warranty lasts, so the above limitations may not apply to you.

Other Rights This Warranty gives you specific legal rights and you may also have other rights which vary from state to state.

Please fill out the form below and retain for future reference.

Model: WaterMaker Five

Date Code: _____

Install Date: _____

Sold by: _____

Installed By: _____

Service Center
Phone Number: _____

WaterMaker^{FIVE} System Specifications

Performance Specifications

	Membrane	System w/Tank
Production	50 GPD (189 LPD)	27 GPD (102 LPD)
TDS Rejection	95%	95%
Recovery ¹	35.4%	22.8%
Brine to Product	1.8:1	3.4:1

¹ The percentage of the feed water available as reverse osmosis treated water under normal operating conditions.

Tested at 60 psig (4 bar), 500ppm TDS municipal water, 77°F (25°C)

Feed Water Requirements

Pressure	40-80 psi (275 kPa - 552 kPa)
Temp	40°F - 100°F (4°C - 38°C)
TDS	<2000 mg/L
Chlorine	<1.0 mg/L
Turbidity	<1 NTU
SDI	<5
pH	4-8

Feed water must be potable, municipal water. Must be free of potential membrane foulants such as Iron, Hydrogen Sulfide and Manganese.

Dimensions and Weight

System - 9.72" W x 13.75" D x 15.38" H (24.7 x 34.9 x 39.1 cm), 11 lbs. (5 kg.)
 Shipping Box - 14.5"L x 11.25"W x 20"H (36.8 x 28.6 x 50.8 cm), 13.7 lbs. (6.2 kg.)

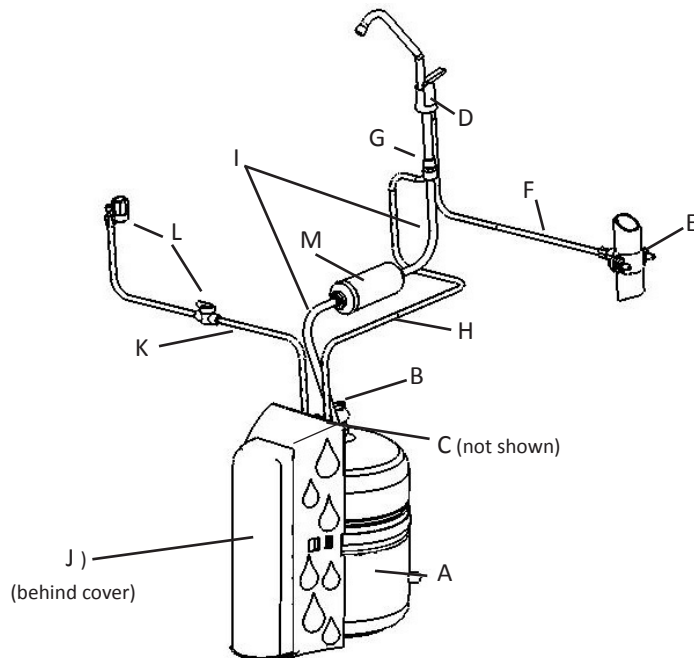

- A. Product water storage tank
- B. Tank valve
- C. Tank tubing (3/8" white)
- D. Air-gap faucet
- E. Drain connection assembly
- F. Drain tubing (3/8" white)
- G. Quick connect fitting
- H. Drain tubing (1/4" black)
- I. Faucet tubing (3/8" blue)
- J. Four-stage desalinator
- K. Feed water tubing (1/4" green)
- L. Inlet fitting with shut-off
- M. Carbon post-filter

This system has been designed for installation by a licensed professional such as a contractor or plumber. Proper completion of this installation will require basic familiarity with standard sink plumbing and proper use of common hand and power tools. Improperly installed systems could result in water damage due to leaks or flooding. Do not use with water that is microbiologically unsafe.

WaterMaker^{FIVE} Push Handle Airgap Faucet

1. Insert polished faucet base and rubber seal onto base of faucet and insert base assembly down through the sink hole.
2. From underneath the sink, push the 1/4" black drain tubing attached to the system onto the 1/4" fitting located on the faucet base.
3. Locate the extra piece of 3/8" white tubing and push one end onto the larger 3/8" fitting located on the faucet base.
4. Slide white plastic spacer open-end-up onto the threaded faucet stem (2).
5. Loosely thread the 3/8" washer (3) and mounting lock nut (4) onto the threaded stem.
6. Thread faucet quick-connect adapter (5) on to threads of faucet stem. NOTE: This connection should be hand-tightened only. Push one end of 3/8" blue tubing into 3/8" connection.
8. Position the faucet to the desired handle orientation. Slip the slotted washer (1) between the white plastic spacer and the sink. Securely hand tighten the mounting nut.
9. Firmly insert spout assembly into the top hole of faucet body (approximately 1/4"). You may swivel the faucet left or right.

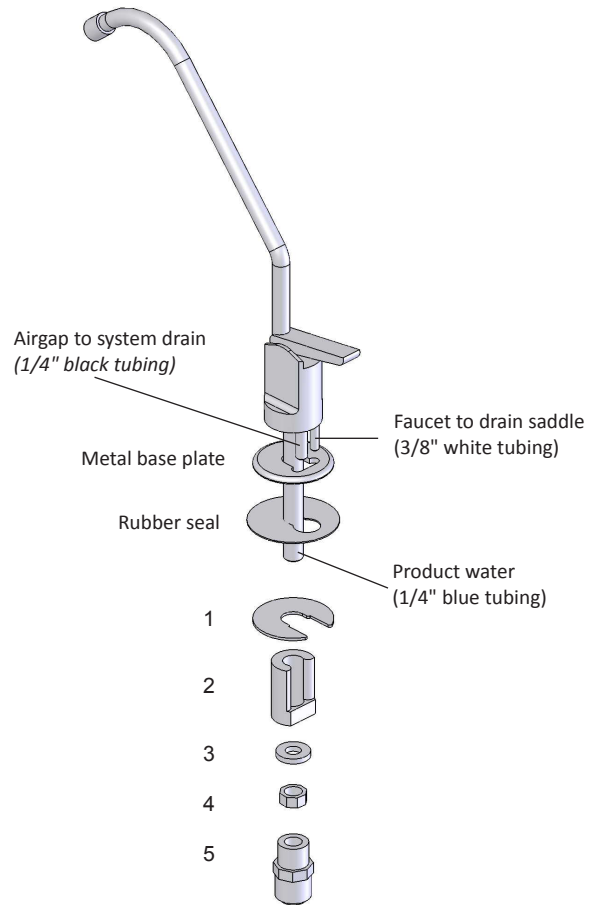

WaterMaker^{FIVE} Feed and Drain Connection

Feed Connection

1. Locate and turn off the angle stop valve on the cold water line feeding the sink. This valve will usually be located under the sink on the pipe coming out of the wall.
2. When the angle stop valve is closed, relieve pressure in the line by opening the cold water tap on the sink.
3. Disconnect the cold water faucet feed line at the angle stop valve.
4. Install the feed adapter into the angle stop. (Fig. 1)
5. Firmly press the green 1/4" tubing into the 1/4" connector on the feed adapter.
6. Connect the cold water faucet feed line into the feed adapter.
7. Attach the small feed valve warning tag from the parts bag to the feed valve.
8. Attach the Shutoff Warning label to the system so that it is directly visible. Fill out the Date of Installation label and attach to the side of the system.

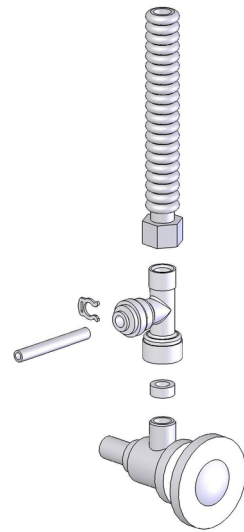

Fig. 1

Drain Connection

Note: The drain saddle assembly must be installed before the 'P' trap. Do not install the drain saddle assembly between the 'P' trap and the wall.

1. Position drain saddle assembly (Fig. 2) on drain pipe under sink between the P trap and the sink connection.
2. Orient the drain saddle so that the connector opening points in the general direction of the planned location for the R.O. dispensing faucet.
3. Using the connector opening in the side of the drain saddle as a guide, drill a 3/8" hole through the wall of the drain pipe. (Fig. 3)
4. Remove drain saddle assembly. Place the adhesive foam pad over the 3/8" hole in the drain pipe. Replace the assembly onto the drain pipe, aligning the hole in the drain with the hole in the drain assembly.
5. Tighten the saddle bolts evenly on both sides until the saddle grips the pipe snugly - do not overtighten. (Fig. 3)
6. Insert the drain tube from the R.O. dispensing faucet through the drain saddle connector nut. Tighten the connector nut onto the drain saddle.

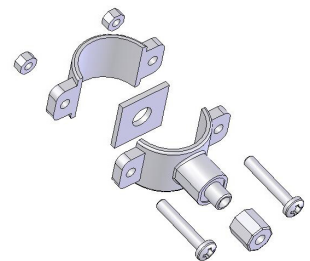

Fig. 2

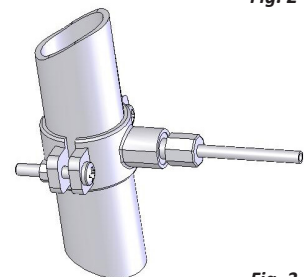

Fig. 3

System Activation and Inspection

1. Check all tubing connections to ensure they are firmly seated. CHECK TO SEE THAT THE CARTRIDGE RETAINER CLIP IS PROPERLY ENGAGED AND LOCKED. Failure to keep the retaining clip in place will result in accidental leaks and flooding.
2. Open the dispensing faucet at the sink. Close the tank shut-off valve.
3. Open the feed water valve to the system. Observe all tubing and connections for several minutes to detect any leaks. In approximately 5 minutes, (assuming normal feed water pressure) the dispensing faucet should begin dripping.
4. Place a pan or other temporary water basin near the drain 'P' trap. Loosen the connector nut holding the 3/8" tube in the drain saddle connector. Pull the tube out of the connector and use the pan to catch any water that may spill. Brine water should be flowing from the tube. Reconnect the tube to the drain saddle and hand-tighten the connector nut.
5. Allow the faucet the run for up to 15 minutes, then close the faucet.
6. Check for leaks at all connections.
7. Open the tank shut-off valve.

Initial Flushing Procedure

1. Before the system can be used for drinking water production it must be adequately flushed. Each reservoir tank is dosed with a small amount of powdered sanitizer before shipment, typically a chlorinating agent, in order to ensure tank internal cleanliness. Also, the carbon filter cartridge will release a small amount of carbon fines during the first tankful of flow. This flushing procedure will allow any sanitizer or carbon fines to pass from the system.
2. Initial tank filling will take approximately one hour (based on average feed pressure). When the tank is full, the water pressure will have risen to the point where the automatic shut-off valve inside the system will stop the feed flow through the system. Actuation of the automatic shut-off valve can be determined by either checking for a lack of brine flow to the drain saddle, or by listening very closely near the dispensing faucet for absence of water flow sound though the air gap. When the tank has filled for the first time, it should be left undisturbed for at least 8 hours to ensure proper sanitization.
3. After 8 hours has elapsed, open the dispensing faucet fully and allow the product water to run out to drain at maximum flow. The initial discharge will be dark with the bulk of the carbon particle wash out. There may also be the scent of chlorinated water from the sanitizing agent. When the flow has diminished to a fast drip or small stream, close the dispensing faucet.
4. Fill and flush the tank at least three times prior to use. If necessary, repeat until the chlorination scent has disappeared. It is important that the flush be done at maximum flow (e.g. the tank must be full) to assist in rapid wash out. After this flushing procedure the system is ready for normal use.

WaterMaker^{FIVE} Installation Checklist

1. System is located where it will not be subject to physical impacts or rough contact by heavy objects.
2. Feed water pressure to the unit is no less than 40 psi and no greater than 80 PSI.
3. Ensure the plastic retainer clip that holds the desalinator cartridge in place is fully engaged and locked in place. The slide locks must snap into place in the slots. If the clip does not snap easily into place through the slots it means the cartridge is not fully inserted into the connectors. Press top or bottom of cartridge to engage connectors until it snaps into place properly.
4. All tubing connections, especially push-in quick connections, are fully inserted.
5. Tubing connected between the faucet and the drain saddle fitting (the fitting attached to the sink drain pipe) runs "down-hill" to the drain. There should be no loops or places where water would not flow out to the drain.
6. Feed water valve is open.
7. Within one to two hours after initial application of water pressure, check again for leaks especially at the tank, faucet tubing and connectors. These parts will not see full pressure until approximately 2 hours after the system is activated.
8. Flush three tankfuls of product water to drain. If a chlorine scent persists, repeat flushing procedure.

WaterMaker^{FIVE} Maintenance

Cartridge Replacement

1. Close the feed water shut-off valve.
2. Close the tank shut-off valve.
3. Open the dispensing faucet to relieve system pressure. Close dispensing faucet when flow has stopped.
4. Remove the cover from the front of the system. Remove the retaining clip. Pull the cartridge off the system evenly at top and bottom. Dispose of used cartridge.
6. Install the new cartridge, rocking gently from side to side as necessary until the cartridge tubes are properly engaged in the unit connectors. Install the retaining clip, ensuring the slide locks snap into place in the slots. If the clip does not snap easily into place through the slots it means the cartridge is not fully inserted into the connectors. Press the top or bottom of the cartridge to engage the connector so that it snaps fully into place. Failure to properly install the retaining clip will result in accidental leaks and flooding.
7. Turn on feed water shut-off valve and open dispensing faucet.
8. Close dispensing faucet after water starts running.
9. Observe system for any leaks, especially at newly replaced cartridge.
10. Open the tank shut-off valve.
11. The system should be flushed at least once as described above under Section 8.

Post Filter Replacement

1. Close the feed water shut-off valve.
2. Close the tank shut-off valve.
3. Open the dispensing faucet.
4. Close the dispensing faucet when the water stops flowing.
5. Locate the inline filter on the faucet line.
6. Remove the red locks from the collets.
7. Remove the tubing by depressing the collet in a downward direction and pulling the blue tubing from the filter.
8. Remove the other side of the feed tubing as described above.
9. Reverse the above steps to install the new inline filter, making sure that the tubing is pressed in as far as possible.
10. Turn on the feed water valve. Observe system for any leaks, especially at newly replaced cartridge.
11. Open the tank shut-off valve.
12. The system should be flushed at least once as described in System Activation and Flushing.